

**SOUTHERN UNIVERSITY AND A&M COLLEGE**

**BATON ROUGE CAMPUS**

**REQUEST FOR BID (BID # 10315)**

**FEBRUARY 29, 2024 @ 10:30 AM**

**RESTROOM RENOVATIONS**

**Location: Laboratory School**

*Firm: DOMAIN Architecture*

*Contacts: Austin Duhon.....[aduhon@domainbr.com](mailto:aduhon@domainbr.com)*

*Ingrid Williams....[iwilliams@domainbr.com](mailto:iwilliams@domainbr.com)*

*225-216-3770*

**MANDATORY PRE—BID CONFERENCE  
AND SITE VISIT:**

**FEBRUARY 9, 2024 @ 10:30 AM**  
Physical Plant Department  
Benjamin H. Kraft Building  
515 James L. Hunt Street  
Southern University  
Baton Rouge Campus  
Site Telephone No. 225-771-4741

**DEADLINE TO SUBMIT INQUIRIES:  
SUBMIT INQUIRIES TO:**

**FEBRUARY 15, 2024 by 5:00 PM**  
**Linda Antoine**  
Email: [linda\\_antoine@subr.edu](mailto:linda_antoine@subr.edu)

**DEADLINE TO RESPOND TO INQUIRIES FEBRUARY 20, 2024 by 5:00 PM**

*Note: Responses to inquiries/Addenda are pasted on LaPAC (LA Procurement Website)*

*LA State Procurement website:*

*<https://wwwcfprd.doa.louisiana.gov/OSP/LaPAC/Agency/outMain.cfm>*

*It is the responsibility of the vendor to check LAPAC for addenda.*

**DEADLINE TO SUBMIT BID:  
SUBMIT BID TO:**

**FEBRUARY 29, 2024 @ 10:30 AM**  
Linda Antoine, Director  
Southern University Purchasing  
Department-P. O. Box 9534 or  
James L. Prestage Drive  
J. S. Clark Adm. Bldg. Annex, 1<sup>st</sup>Floor  
Baton Rouge, LA 70813  
Telephone No. 225-771-2804 or 771-4580

**ADVERTISEMENT  
REQUEST FOR BID  
BID # 10315  
RESTROOM RENOVATIONS  
SOUTHERN UNIVERSITY AND A&M COLLEGE  
LABORATORY SCHOOL  
FEBRUARY 29, 2024-10:30 AM**

Sealed bids will be received by Southern University, Baton Rouge, Louisiana, in the Purchasing Office, 8100 James L. Prestage Drive, J. S. Clark Administration Building Annex, South Entrance, First Floor East. Bidders are solely responsible for ensuring timely delivery of their bids. The Southern University Purchasing Department is not responsible for any delays caused by bidders' chosen means of delivery. Failure to meet the bid deadline submittal date and time shall result in rejection of bid.

**MAIL OR HAND-DELIVER BID TO PURCHASING DEPARTMENT NO  
LATER THAN 10:30 AM-FEBRUARY 29, 2024**

**Mandatory Pre-Bid Conference & Site Visit: February 9, 2024 @ 10:30 am**  
**Site Visit Location: 515 Benjamin Kraft Physical Plant Building**  
**515 James L. Hunt Street (Southern University Campus)**  
**Baton Rouge, La 70813**  
**Site Visit Telephone Number: 225-771-4741**

**Participants shall be in attendance by 10:30 a.m. and sign-in on sheet provided by the Purchasing Department.**

Bidders shall visit the site and be familiarized with the local conditions under which the work is to be performed. No additional compensation will be granted because of unusual difficulties, which may be encountered in the execution of any portion of the work.

Inquiries will be accepted until February 15, 2024 by 5:00 p.m. Inquiries shall be submitted to Linda Antoine, Director of Purchasing at [linda\\_antoine@subr.edu](mailto:linda_antoine@subr.edu)

Responses to inquiries will be posted on LaPAC-LA State Procurement website by February 20, 2024 by 5:00 p.m. Bidders have the responsibility of checking the LaPAC website for responses/addenda.

Any person requiring special accommodations should notify the Purchasing Office of the type(s) of accommodation required not less than seven (7) days before the bid opening date.

All bids must be accompanied by bid security equal to **five (5%) percent of the sum of the base bid and all alternates, if applicable** and must be in the form of a certified/official check, cashier's check or bid bond, made payable to Southern University and A & M College. Surety represents that it is listed on the current U.S. Department of the Treasury Financial Management Service list of approved bonding companies and that is listed thereon as approved for amount equal to or greater than the amount for which it

obligates itself in this instrument. No bid bond indicating an obligation of less than five percent (5%) by any method is acceptable.

The successful bidder shall be required to furnish a **Performance and Payment Bond** written by a company licensed to do business in Louisiana, in an amount equal to 100% of the contract amount and who is currently on the U.S. Department of the Treasury Financial Management Service List.

Bidders shall include the following on envelope of choice: company's name, address, Louisiana contractor's license number, bid number, bid opening date and time.

Bids may be withdrawn by written, telegraphic fax notice or email and received at the address or email address designated in the Invitation to Bid prior to the time set for bid opening, as recorded by date stamp at the Purchasing Office. Bids received after closing time will be returned unopened. Evidence of authority to submit the bid shall be required in accordance with R.S. 38:2212(a)(1)(c) and/or R.S. 39:1594(c)(2)(d).

The Southern University System is a participant in the Louisiana for the Small Entrepreneurships Program (the Hudson Initiative) and the Louisiana Initiative for Veterans and Service-Connected Disabled Veterans-Owned Business Small Entrepreneurships. Bidders are encouraged to consider participation. A list of certified vendors and additional information can be obtained from website <http://www.ledsmallbiz.com>. Potential participants may also register at this website.

**ALL BID SPECIFICATIONS CAN BE OBTAINED BY ACCESSING THE LA STATE PROCUREMENT WEBSITE**

**<https://wwwcfprd.doa.louisiana.gov/osp/lapac/pubMain.cfm>**

Any questions concerning bid documents, please contact Mary Jane Spruel, Assistant Director of Purchasing at (225) 771-2800 or email to [Maryjane\\_spruel@subr.edu](mailto:Maryjane_spruel@subr.edu)

The University reserves the right to reject all bids and to waive any informalities incidental thereto. Bids will be accepted only from contractors who are licensed under Louisiana R.S. 39:2150-2173 for the classification of: 72000000 Building and Construction, and Maintenance Services; 72100000 Building and Construction, and Maintenance and Repair Services; 72131600 Commercial or Industrial Construction.

**SOUTHERN UNIVERSITY & A&M COLLEGE  
AN EQUAL OPPORTUNITY EMPLOYER  
Linda A. Antoine, Director of Purchasing**

**DATES ADVERTISED:  
FEBRUARY 1, 2024, FEBRUARY 8, 2024 & FEBRUARY 15, 2024**

# LOUISIANA UNIFORM PUBLIC WORK BID FORM

**TO:** Southern University and A&M College  
Post Office Box 9534  
James J. Prestage Dr-J.S. Clark Adm. Bldg. Annex  
Baton Rouge, LA 70813

**BID FOR:** Bid Number 10315  
RESTROOM RENOVATIONS  
Laboratory School  
Southern University and A&M College  
Baton Rouge Campus

The undersigned bidder hereby declares and represents that she/he: a) has carefully examined and understands the Bidding Documents, b) has not received, relied on, or based his bid on any verbal instructions contrary to the Bidding Documents or any addenda, c) has personally inspected and is familiar with the project site, and hereby proposes to provide all labor, materials, tools, appliances and facilities as required to perform, in a workmanlike manner, all work and services for the construction and completion of the referenced project, all in strict accordance with the Bidding Documents prepared by: Purchasing Department 1/19/2024

Bidders must acknowledge all addenda. The Bidder acknowledges receipt of the following **ADDENDA:** (Enter the number the Designer has assigned to each of the addenda that the Bidder is acknowledging) N/A

**TOTAL BASE BID:** For all work required by the Bidding Documents (including any and all unit prices designated "Base Bid" \* but not alternates) the sum of:  
\_\_\_\_\_ Dollars (\$ \_\_\_\_\_)

**ALTERNATES:** For any and all work required by the Bidding Documents for Alternates including any and all unit prices designated as alternates in the unit price description. (N/A)

**Alternate No. 1** (Owner to provide description of alternate and state whether add or deduct) for the lump sum of:  
\_\_\_\_\_ Dollars (\$ \_\_\_\_\_)

**Alternate No. 2** (Owner to provide description of alternate and state whether add or deduct) for the lump sum of:  
\_\_\_\_\_ Dollars (\$ \_\_\_\_\_)

**Alternate No. 3** (Owner to provide description of alternate and state whether add or deduct) for the lump sum of:  
\_\_\_\_\_ Dollars (\$ \_\_\_\_\_)

**NAME OF BIDDER:** \_\_\_\_\_

**ADDRESS OF BIDDER:** \_\_\_\_\_

**EMAIL:** \_\_\_\_\_

**PHONE:** \_\_\_\_\_

**LOUISIANA CONTRACTOR'S LICENSE NUMBER:** \_\_\_\_\_

**PRINT NAME OF AUTHORIZED SIGNATORY OF BIDDER:** \_\_\_\_\_

**TITLE OF AUTHORIZED SIGNATORY OF BIDDER:** \_\_\_\_\_

**SIGNATURE OF AUTHORIZED SIGNATORY OF BIDDER:** \_\_\_\_\_

**DATE:** \_\_\_\_\_

Completion Time: \_\_\_\_\_ consecutive calendar days, or within the time that may be extended as stipulated in the contract.

Liquidated Damages: \$150 per day.

**5% Bid Security:** XX YES (shall be included with bid)

(check here) \_\_\_\_\_ Bid Security included. Bid Security shall be total of 5% for base bid and alternates.

Successful bidder will be notified by letter to secure Performance and Payment Bond up to 100% of cost.

(check here) \_\_\_\_\_ Board Resolution included or Secretary of State Registration

**A CORPORATE RESOLUTION OR WRITTEN EVIDENCE** of the authority of the person signing the bid for the public work as prescribed by LA R.S. 38:2212(B)(5) or Secretary of State verification.

**BID SECURITY** in the form of a bid bond, certified check or cashier's check as prescribed by LA RS 38:2218.A is attached to and made a part of this bid.

The Unit Price Form shall be used if the contract includes unit prices. *Otherwise it is not required and need not be included with the form.* The number of unit prices that may be included is not limited and additional sheets may be included if needed.

# LOUISIANA UNIFORM PUBLIC WORK BID FORM

## UNIT PRICE FORM

TO: Southern University and A&M College

Post Office Box 9534

James J. Prestage Dr.-J. S. Clark Administration Bldg. Annex

Baton Rouge, LA 70813

BID FOR: Bid Number 10316

RESTROOM RENOVATIONS-SU LABORATORY SCHOOL

**UNIT PRICES:** This form shall be used for any and all work required by the Bidding Documents and described as unit prices. Amounts shall be stated in figures and only in figures.

DESCRIPTION:	<input type="checkbox"/> Base Bid or <input type="checkbox"/> Alt.# _____	UNIT OF MEASURE:	UNIT PRICE	UNIT PRICE EXTENSION (Quantity times Unit Price)
REF. NO.	QUANTITY:			
DESCRIPTION:	<input type="checkbox"/> Base Bid or <input type="checkbox"/> Alt.# _____	UNIT OF MEASURE:	UNIT PRICE	UNIT PRICE EXTENSION (Quantity times Unit Price)
REF. NO.	QUANTITY:			
DESCRIPTION:	<input type="checkbox"/> Base Bid or <input type="checkbox"/> Alt.# _____	UNIT OF MEASURE:	UNIT PRICE	UNIT PRICE EXTENSION (Quantity times Unit Price)
REF. NO.	QUANTITY:			
DESCRIPTION:	<input type="checkbox"/> Base Bid or <input type="checkbox"/> Alt.# _____	UNIT OF MEASURE:	UNIT PRICE	UNIT PRICE EXTENSION (Quantity times Unit Price)
REF. NO.	QUANTITY:			
DESCRIPTION:	<input type="checkbox"/> Base Bid or <input type="checkbox"/> Alt.# _____	UNIT OF MEASURE:	UNIT PRICE	UNIT PRICE EXTENSION (Quantity times Unit Price)
REF. NO.	QUANTITY:			
DESCRIPTION:	<input type="checkbox"/> Base Bid or <input type="checkbox"/> Alt.# _____	UNIT OF MEASURE:	UNIT PRICE	UNIT PRICE EXTENSION (Quantity times Unit Price)
REF. NO.	QUANTITY:			
DESCRIPTION:	<input type="checkbox"/> Base Bid or <input type="checkbox"/> Alt.# _____	UNIT OF MEASURE:	UNIT PRICE	UNIT PRICE EXTENSION (Quantity times Unit Price)
REF. NO.	QUANTITY:			

**Warning for "DESCRIPTION"** is to be provided by the Owner.  
 All quantities are estimated. The contractor will be paid based upon actual quantities as verified by the Owner.

**JOB SITE VISIT**

**NAME OF PROJECT: EXTERIOR WINDOWS & CANOPY REPAIRS**

**BUILDING: LABORATORY SCHOOL**

**SOUTHERN UNIVERSITY AND A & M COLLEGE**

**BATON ROUGE, LOUISIANA**

**SITE VISIT DATE: FEBRUARY 9, 2024 @ 10:30 AM-BID # 10315**

**LATE ARRIVALS CANNOT PARTICIPATE IN THE BID PROCESS**

*It is the responsibility of the bidder to inspect job site, verify any measurements and/or supplies needed prior to submitting a bid price on this project. Each bidder shall fully acquaint himself with conditions relating to construction and labor so that he may fully understand the facilities, difficulties and restrictions attending the execution of work under this contract. If vendor finds conditions that disagree with the physical layout as described in the bid, or any other features of the specifications that appear to be in error, same shall be noted on proposal. Failure to do so will be interpreted that bid is as specified. No consideration or allowance will be granted the Contractor for failure to visit the site or for any alleged misunderstanding of the materials to be furnished or the work to be done.*

**JOB SITE VISIT LOCATION:**

**Benjamin H. Kraft Building (Physical Plant Department)**

**515 James L. Hunt Street**

**Southern University Baton Rouge Campus**

**Site telephone numbers: (225) 771 -4741 , 771 -4742 or 771 -4743**

*The signed statement certifies the vendor's name listed below has visited the proposed site and is familiar with all conditions surrounding fulfillment of the specifications for this project.*

COMPANY \_\_\_\_\_

BY \_\_\_\_\_

DATE \_\_\_\_\_

**Note:** Questions not answered at Site Visit or any additional questions shall be submitted in writing to the Director of Purchasing, Linda A. Antoine at linda\_antoine@subr.edu.

*Note: Responses to inquiries/Addenda are posted on LaPAC (LA Procurement Website)*

*LA State Procurement website:*

<https://wwwcfprd.doa.louisiana.gov/OSP/LaPAC/Agency/outMain.cfm>

***It is the responsibility of the vendor to check LAPAC for addenda.***

**JOB SITE VERIFIED BY DESIGNATED SOUTHERN UNIVERSITY EMPLOYEE:**

\_\_\_\_\_  
**SIGNATURE**

Return this sheet with bid for information purpose

**SOUTHERN UNIVERSITY AND A&M COLLEGE  
BATON ROUGE CAMPUS  
REQUEST FOR BID**

**PROJECT: RESTROOM RENOVATIONS**

**LOCATION: LABORATORY SCHOOL**

**BID DUE DATE: FEBRUARY 29, 2024 @ 10:30 AM**

**BID # 10315**

Bids submitted are subject to provisions of but not limited to La.R.S.38 Purchasing Rules and Regulations; Executive Orders; and the General Terms and Conditions, listed in this Invitation for Bid. Southern University reserves the right to award items separately, grouped or on an all or none basis and to reject any or all bids and waive any informalities.

**BIDS MAY BE SENT BY MAIL OR HAND-DELIVERED TO:**

**Bids should be mailed to:**

Southern University  
Purchasing Department  
Post Office Box 9534  
Baton Rouge, Louisiana 70813

**As an alternative, bids may be hand delivered to:**

Southern University  
Purchasing Department  
1<sup>st</sup> Floor East-James L. Prestage Drive  
J. S. Clark Administration Building  
Baton Rouge, Louisiana 70813

**MANDATORY PRE-BID CONFERENCE & SITE VISIT: FEBRUARY 9, 2024 @ 10:30 AM**

**INQUIRIES:**

No negotiations, decisions, or actions will be executed by any bidder as a result or any oral discussion with any University employee or State Consultant. Only those transactions which are in writing, sent to **Linda A. Antoine, Director of Purchasing, will be considered as valid.**

**INSTRUCTIONS TO BIDDERS**

**1. Bid Forms**

All written bids, unless otherwise provided for, must be submitted on, and in accordance with forms provided and properly signed in ink. Bids submitted in the following manner will not be accepted:

Bid containing no signature indicating intent to be bound

(1) Bid filled out in pencil

(2) Bid not submitted on University standard forms

Bids must be received at the address specified in the Invitation for Bid prior to bid opening time in order to be considered. .

**2. Envelope (if mailed)**

Bidders are requested to submit bid package in a sealed envelope of your choice that is clearly marked identifying the *company's name, complete address, bid number, time and date of bid opening, and license number, if applicable.*

Bidder is responsible for means of delivery of bid.

**Louisiana Contractors License Number shall be placed on the outside of the envelope.**

**3. Standards of Quality**

Any product or service bid shall conform to all applicable federal, state and local laws, regulations and the specifications contained in the IFB. Unless otherwise specified in the IFB, any manufacturer's name, trade name, brand name, or catalog numbers used in the specifications is for the purpose of describing the quality level, performance and characteristics required. Bidder must specify the brand and model number of the product offered in his/her bid. Bids not specifying brand and model numbers will be considered as offering the exact product(s) specified in the IFB.

**4. Descriptive Information**

Bidders proposing an equivalent brand or model should submit information with bid (such as illustrations, descriptive literature, technical data) sufficient for the University to evaluate quality, suitability and compliance with the specifications in the IFB. Failure to submit descriptive information may cause bid to be rejected. Any change made to a manufacturer's published specification submitted for a product should be verifiable by the manufacturer. If item(s) bid do not fully comply with specifications (including brand and/or product number), bidder must state in what respect the item(s) deviate. Failure to note exceptions on the bid form will not relieve the successful bidder(s) from supplying the actual products requested.

**5. ON-CAMPUS ATTENDANCE REQUIREMENTS (COVID-19)**

**This document will be included with the successful vendor's contact.**

The Center for Disease and Control (CDC) recommends social distancing and wearing masks to prevent the spread of the Corona Virus (COVID-19).

**6. Prices**

Unless otherwise specified by the Purchasing Department, bid prices must be complete, including transportation, prepaid by bidder to destination. In the event of extension errors, the unit price shall prevail.

**7. Payment Terms**

Payment is to be made within thirty (30) days after receipt of properly executed invoice, or delivery and acceptance, whichever is later. Delinquent payment penalties are governed by **L.R.S. 39:1695**.

**8. Deliveries**

Bids may be rejected if the delivery or completion time indicated is longer than that specified in the IFB.

**9. Vendor Invoices**

Invoices or AIA payment form shall reference the Southern University purchase/release order number, vendor's packing list/delivery ticket, ticket number, shipping/delivery date, etc. Invoices are to be itemized and billed in accordance with the order and should show the amount of any prompt payment discount and submitted on the vendor's own invoice form. Invoices submitted by the vendor's supplier will not be accepted. Terms are net 30.

**10. Tax Information/State of Louisiana**

Vendor is responsible for including all applicable taxes in the bid prices. Southern University is exempt from all Louisiana state and local sales and use taxes. By accepting an award, resident and non-resident firms acknowledge their responsibility for the payment of all taxes duly assessed by the State of Louisiana and its political subdivisions for which they are liable, including but not limited to: franchise taxes, privilege taxes, sales taxes, use taxes, ad valorem taxes, etc. In accordance with Act Number 1029 of the 1991 Regular Session, effective September 1, 1991 state agencies will no longer be required to pay state sales tax.

**11. New Products**

Unless specifically called for, all products for purchases must be new (never previously used) and the current model and/or packaging. The manufacturer's standard warranty will apply unless otherwise specified in the IFB.

**12. Contract Renewals, Multi-Year Contracts (if applicable)**

Upon agreement of Southern University and the contractor, an open-ended requirements contract may be extended for two (2) additional twelve (12) month periods at the same prices, terms and conditions. In such cases, the total contract term cannot exceed thirty six (36) months.

**13. Contract Cancellation**

Southern University has the right to cancel any contract, in accordance with Purchasing Rules and Regulations, for cause, including but not limited to, the following: (1) failure to deliver within time specified in the contract; (2) failure of the product or service to meet specifications, conform to sample quality or to be delivered in good condition; (3) misrepresentations by the contractor; (4) fraud, collusion, conspiracy or other unlawful means of obtaining any contract with the state; (5) conflict of contract provisions with constitutional or statutory provision of state or federal law; (6) any other breach of contract.

**14. AWARD AND EXECUTION OF CONTRACT:**

The owner shall incur no obligation to the contractor until the contract between the owner and contractor is duly executed. If the contractor is notified of the acceptance of the bid within thirty (30) days of the opening bid date, contractor agrees to execute and deliver to owner, Performance and Payment Bond and Certificate of Insurance, a copy of which is attached to the Contract Documents, within ten (10) working days after notice from the Owner that the instrument is ready for signature.

**15. Fiscal Funding Clause (Renewal Contracts Only)**

**In accordance with LA R.S.39:1615 (c) and (e), any contract entered into by the State of Louisiana and Southern University shall include the following Fiscal Funding Clause:**

**C.** Termination due to unavailability of funds in succeeding years. When funds are not appropriated to support continuation of performance in a subsequent year of a multiyear contract, the contract for such subsequent year shall be terminated. When a contract is terminated under these conditions, no additional funds shall be paid to the contractor as a result of such action. **E.** With respect to all multiyear contracts, there shall be no provisions for a penalty to the state for the cancellation or early payment of the contract. The continuation of this contract is contingent upon the appropriation of funds to fulfill the requirements of the contract by the legislature. All proposers should be aware that our legislative process is such that it is often impossible to give prior notice of the non-appropriation of funds.

**This document will be included with the successful vendor's contact.**



**16. Default of Contractor**

Failure to deliver within the time specified in the bid will constitute a default and may cause cancellation of the contract. Where the state had determined the contractor to be in default, the state reserves the right to purchase any or all products or services covered by the contract on the open market and to charge the contractor with cost in excess of the contract price. Until such assessed charges have been paid, no subsequent bid from the defaulting contractor will be considered.

**17. Order of Priority**

In the event there is a conflict between the Instructions to Bidders the General Terms and Conditions will govern.

**18. Applicable Law**

All contracts will be construed in accordance with and governed by the laws of State of Louisiana. Vendors shall be in compliance with applicable laws of the State of Louisiana and Federal Laws where applicable, to include licenses, fees and permits. Vendors are responsible for the cost of licenses, fees and permits.

**19. Certification of No Suspension or Debarment (\$25,000 or more)**

By signing and submitting this bid, bidder certifies that its company, any subcontractors, or principals thereof, are not suspended or debarred under federal or state laws or regulations. A list of parties who have been suspended or debarred by federal agencies is maintained by the General Services Administration and can be viewed on the internet at [www.sam.gov](http://www.sam.gov).

**Federal Funded**      **Non-Federal Funded**

**20. E-VERIFY (verification of employees)**

Contractor acknowledges and agrees to comply with the provisions of La R.S. 38:2212.10 and federal law pertaining to E-Verify in the performance of services under this contract.

**21. Prohibited Contractual Arrangements**

Per Louisiana R.S. 42:1113.a, no public servant, or member of such public servant's immediate family, or legal entity in which he is a controlling interest shall bid on or enter into any contract, subcontract, or other transaction that is under the supervision or jurisdiction of the agency of such public servant. See statute for complete law, exclusions and provisions.

**22. Discriminatory Boycotts of Israel**

*This section applies to procurements with a value of \$100,000 or more and for vendors with five (5) or more employees*

**Prohibition of Discriminatory Boycotts of Israel**

In accordance with R.S. 39:1602.1, for any contract for \$100,000 or more and for any contractor with five or more employees, the Contractor certifies that neither it nor its subcontractors are engaged in a boycott of Israel, and that the Contractor and any subcontractors shall, for the duration of this contract, refrain from a boycott of Israel. The State reserves the right to terminate this contract if the Contractor, or any Subcontractor, engages in a boycott of Israel during the term of this contract.

**23. Mutual Indemnification**

Each party hereto agrees to indemnify, defend and hold the other, its officers, directors, agents and employees harmless from and against any and all losses, liabilities and claims, including reasonable attorney's fees arising out of or resulting from the willful act, fault, omission, or negligence of the indemnifying party or of its employees, contractors, or agents in performing its obligations under this agreement, provided however, that neither party hereto shall be liable to the other for any consequential damages arising out of its willful act, fault, omission, or negligence.

**24. Fair Labor Standards Act**

Contractor shall be in compliance with the **Fair Labor Standards Act 29 USC 201-6**; Establishes minimum wage, overtime pay, equal pay, recordkeeping, and child labor standards for employees or in the production of goods for interstate commerce. By signing and submitting this bid, bidder certifies that its company, any subcontractors, or principals thereof is in accordance with said compliance. United States Department of Labor website: [www.dol.gov/esa](http://www.dol.gov/esa)

**25. Davis-Bacon Act (\$2,000 or more)**

Contractor shall be in compliance with the **Davis-Bacon Act, 40 USC 276A-7**; ensures that laborers and mechanics employed pursuant to federally funded construction contracts, subcontracts and construction under Federal grants, will be paid wages as determined by the U.S. Secretary of Labor. By signing and submitting this bid, bidder certifies that its company, any subcontractors, or principals thereof is in accordance with said compliance. United States Department of Labor website: [www.dol.gov/esa](http://www.dol.gov/esa)

**Federal Funded**      **Non-Federal Funded**

**26. Small Business Entrepreneurship Programs**

The Southern University System is a participant in the Louisiana for the Small Entrepreneurships Program (the Hudson Initiative) and the Louisiana Initiative for Veterans and Service-Connected Disabled Veterans-Owned Business Small Entrepreneurships. Bidders

**This document will be included with the successful vendor's contact.**

are encouraged to consider participation. A list of certified vendors and additional information can be obtained from website <http://www.ledsmallbiz.com>. Potential participants may also register at this website. Businesses include minority and women.

**27. Public Works Projects (R.S. 38:2227)**

In accordance with the provisions of R.S. 38:2227; in awarding public works projects, any public entity is authorized to reject a proposal or bid, or not award the contract, to a business in which any individual with an ownership interest of ten percent (10%) or more, has been convicted, or has entered a plea of guilty or nolo contendere to any state felony or equivalent federal felony crime.

**28. Tobacco-Free Policy**

The use of tobacco products on any Southern University campus is prohibited by students, staff, faculty or visitors in all campus buildings, facilities, or property owned or leased by Southern University System and outside areas of the campus where non-smokers cannot avoid exposure to smoke; on campus grounds, facilities, or vehicles that are the property of the University; and at lectures, conferences, meetings, and social and cultural events held on school property or school grounds. The sale or free distribution of tobacco products, including merchandise on campus or at school events is prohibited.

**29. Equal Opportunity Employer**

Southern University and A&M College Systems of the State of Louisiana is an equal opportunity employer and looks to its contractors, sub-contractors, vendors, and suppliers to take affirmative action to effect this commitment in its operations. By submitting and signing this bid, the bidder certifies that he agrees to adhere to the mandates dictated by Title VI and VII of the Civil Rights Act of 1964, as amended; the Vietnam Era Veterans' Readjustment Assistance Act of 1974; Section 303 of the Rehabilitation Act of 1973; Section 202 of Executive Order 12414, as amended; and the Americans with Disabilities Act of 1990. Bidder agrees that he will not discriminate in the rendering of services to and/or employment of individuals because of race, color, religion, sex, age, national origin, handicap, disability, veteran status, or any other non-merit factor. Bidder further agrees to keep informed of and comply with all Federal, State, and local laws, ordinances, and regulations which affect his employees or prospective employees. Any person who is a "Qualified Individual with a Disability" as defined by 42 USC 12131 of the American with Disabilities Act who has submitted a bid on this procurement and who desires to attend the bid opening, must notify this office in writing no later than seven (7) working days prior to the bid opening date of their need for special accommodations. If the requested accommodations cannot be reasonably provided, the individual will be so informed prior to the bid opening.

**30. Code of Ethics**

The contractor acknowledges that Chapter 15 of Title 42 of the Louisiana Revised Statutes (R.S. 42:1101 et. seq., Code of Governmental Ethics) applies to the Contracting Party in the performance of services called for in this contract. The contractor agrees to immediately notify the state if potential violations of the Code of Governmental Ethics arise at any time during the term of this contract.

**31. Vendor Forms/SU Signature Authority**

The terms and conditions of the SU solicitation and purchase order/contract shall solely govern the purchase agreement, and shall not be amended by any vendor contract, form, etc. The University's chief procurement officer, or designee, is delegated sole authority to execute any vendor contracts, forms, etc. Departments are prohibited from signing any vendor forms.

**32. Prosecution of Work**

The work is to be done when Southern University is in operation. The contractor shall, therefore, plan the repairs and installation in specifications so as not to interfere with normal operations of the facility and shall exert effort to expedite completion of the work once it has started. It is intended that the work shall be done during normal working hours, however, should work require overtime (Saturday, Sunday and/or night working hours), the cost must be borne by the contractor at no extra compensation from the Owner (Southern University).

**33. On-Campus Attendance Requirements (COVID-19)**

The Center for Disease and Control (CDC) recommends social distancing and wearing of masks to prevent the spread of the Coronavirus (COVID19). Persons visiting Southern University are required to wear a mask/face covering and stay at least 6 feet between yourself and others, even when you wear a face covering.

**34. Termination of the Contract for Convenience**

The State/University may terminate the contract at any time by giving thirty (30) days written notice to the Contractor of such termination or negotiating with the Contractor an effective date. The Contractor shall be entitled to payment for deliverables in progress, to the extent work has been performed satisfactorily.

**35. Termination for Cause**

The State may terminate this Contract for cause based upon the failure of the Contractor to comply with the terms and/or conditions of the Contract; provided that the State shall give the Contractor written notice specifying the Contractor's failure. If within thirty (30) days after receipt of such notice, the Contractor shall not have either corrected such failure or thereafter proceeded diligently to complete such correction, then the State may, at its option, place the Contractor in default and the Contract shall terminate on the date specified in such notice. The Contractor may exercise any rights available to it under Louisiana law to terminate for cause upon the

**This document will be included with the successful vendor's contact.**

failure of the Owner to comply with the terms and conditions of this contract; provided that the Contractor shall give the State written notice specifying the State's failure and a reasonable opportunity for the Owner to cure the defect.

**36. Auditors**

It is hereby agreed that the Legislative Auditor of the State of Louisiana and/or the Office of the Governor, Division of Administration auditors shall have the option of auditing all accounts of contractor which relate to this contract.

**37. Awarded Products/Unauthorized Substitutions**

Only those awarded brands and numbers stated in the SU contract are approved for delivery, acceptance, and payment purposes. Any substitutions require prior approval of the Purchasing Office. Unauthorized product substitutions are subject to rejection at time of delivery, post-return at vendor's expense, and non-payment.

**38. Acceptance**

Upon written notice by the Owner, a Notice by Owner of Acceptance of Work will be executed and forwarded to the Contractor for recording with the Clerk of Court in the parish in which the work has been performed and shall furnish a clear Lien Certificate from the Clerk of Court (to the owner along with final invoice) forty-five (45) days after recordation of acceptance. Final payment of ten percent (10%) will be made at this time.

**39. Guarantee**

It is the intention of the specifications to secure a first-class permanent material and construction and to this end, Contractor will be held responsible for and must correct defects discovered in the work within one (1) year from acceptance. Should any materials or methods be called for, of such nature to render this guarantee impossible, written notice to this effect should be given Owner (Southern University) before signing contract and/or beginning of work; failure to do this will be construed as agreement to the strictest terms of the guarantee.

**40. Clean-Up**

The Contractor will be directed during the progress of work to remove and properly dispose of the resultant and debris. Upon completion, Contractor shall remove all equipment, unused materials and debris and will leave the premises in a clean and first-class condition.

**41. Examination of Site**

Each bidder will visit the site of the proposed project and will fully acquaint himself with conditions relating to construction and labor so that he may fully understand the facilities, difficulties and restrictions attending the execution of work under this contract. No consideration or allowance will be granted the Contractor for failure to visit the site or for any alleged misunderstanding of the materials to be furnished or the work to be done.

**42. Anti-Kickback Clause**

The Contractor hereby agrees to adhere to the mandate dictated by The Copeland "Anti-Kickback" ACT which provides that each Contractor or Subgrantee shall be prohibited from inducing, by any means, any person employed in the completion of work, to give up any part of the compensation to which he is otherwise entitled.

**43. Clean Air Act**

The Contractor hereby agrees to adhere to the provisions which require compliance with all applicable standards, orders or requirements issued under Section 306 of the CLEAN AIR ACT which prohibits the use under non-exempt contracts, grants or loans of facilities included on the EPA list of Violating Facilities.

**44. Clean Water Act**

The Contractor hereby agrees to adhere to the provisions which require compliance with all applicable standards, orders or requirements issued under Section 508 of the Clean Water Act which prohibits the use under non-exempt federal contracts, grants or loans of facilities included on the EPA list of Violating Facilities.

**45. Energy Policy and Conservation Act**

The Contractor hereby recognizes the mandatory standards and policies relating to energy efficiency which are contained in the State energy conservation plan issued in compliance with the Energy Policy and Conservation Act (P.L. 94-163).

**46. Anti-Lobbying and Debarment Act**

The Contractor will be expected to comply with federal statutes in the Anti-Lobbying Act and The Debarment Act.

**47. Signature Authority**

**A CORPORATE RESOLUTION OR WRITTEN EVIDENCE OF THE AUTHORITY OF THE PERSON SIGNING THE BID FOR THE PUBLIC WORK AS PRESCRIBED BY LOUISIANA REVISED STATUTE 38:2212 (B)(5)**  
**A copy of the applicable signature authority document/Board Resolution or LA Secretary of State Registration must be submitted with bid.**

This document will be included with the successful vendor's contact.

**48. ADDITIONAL REQUIREMENTS**

1. ALL WORK SHALL BE IN ACCORDANCE WITH THE PLANS; THE PROJECT SPECIFICATIONS, AND SHALL COMPLY WITH APPLICABLE LOCAL AND STATE BUILDING CODES AS WELL AS ANY AND ALL REGULATORY AGENCY REQUIREMENTS AND LAWS, INCLUDING BUT NOT LIMITED TO OSHA, ETC. GENERAL NOTES SHALL APPLY TO ALL DRAWINGS.
2. CONTRACTOR SHALL NOTIFY THE ENGINEER/ARCHITECT, IF APPLICABLE, OF ALL CONFLICTS OR DISCREPANCIES PRESENTED IN THESE PLANS PRIOR TO THE START OF WORK.
3. ALL WORK WHETHER SHOWN OR IMPLIED, UNLESS SPECIFICALLY QUESTIONED SHALL BE CONSIDERED UNDERSTOOD IN ALL RESPECTS BY THE GENERAL CONTRACTOR AND WHO WILL BE RESPONSIBLE FOR ANY MISINTERPRETATIONS AND CONSEQUENCES THEREOF.
4. ANY UTILITIES DAMAGED DURING CONSTRUCTION SHALL BE REPAIRED AT THE CONTRACTORS EXPENSE.
5. ENGINEER/ARCHITECT SHALL BE NOTIFIED IMMEDIATELY OF ALL IDENTIFIED EXISTING UTILITIES NOT IDENTIFIED IN THE PLANS.
6. OWNER SHALL PROVIDE WATER FOR CLEANING OPERATIONS FROM ANY FIRE HYDRANT AT NO COST TO THE CONSULTANT.

**THIS DOCUMENT IS FOR INFORMATION PURPOSES**

**This document will be included with the successful vendor's contact.**

## INSURANCE REQUIREMENTS

### Southern University and A&M College

#### RESTROOM RENOVATIONS-LABORATORY SCHOOL-BID 10315

The Contractor shall purchase and maintain for the duration of the contract insurance against claims for injuries to persons or damages to property which may arise from or in connection with the performance of the work hereunder by the Contractor, its agents, representatives, employees or subcontractors.

#### **A. MINIMUM SCOPE AND LIMITS OF INSURANCE**

1. **Workers Compensation**

Workers Compensation insurance shall be in compliance with the Workers Compensation law of the State of the Contractor's headquarters. Employers Liability is included with a minimum limit of \$500,000 per accident/per disease/per employee. If work is to be performed over water and involves maritime exposure, applicable LHWCA, Jones Act, or other maritime law coverage shall be included and the Employers Liability limit increased to a minimum of \$1,000,000. **A.M. Best's insurance company rating requirement may be waived for workers compensation coverage only.**

2. **Commercial General Liability**

Commercial General Liability insurance, including Personal and Advertising Injury Liability, shall have a minimum limit per occurrence of \$1,000,000 and a minimum general aggregate of \$2,000,000. The Insurance Services Office (ISO) Commercial General Liability occurrence coverage form CG 00 01 (current form approved for use in Louisiana), or equivalent, is to be used in the policy. Claims-made form is unacceptable.

3. **Automobile Liability**

Automobile Liability Insurance shall have a minimum combined single limit per occurrence of \$1,000,000. ISO form number CA 00 01 (current form approved for use in Louisiana), or equivalent, is to be used in the policy. This insurance shall include third-party bodily injury and property damage liability for owned, hired and non-owned automobiles.

#### **B. DEDUCTIBLES AND SELF-INSURED RETENTIONS**

Any deductibles or self-insured retentions must be declared to and accepted by the Agency. The Contractor shall be responsible for all deductibles and self-insured retentions.

#### **C. OTHER INSURANCE PROVISIONS**

The policies are to contain, or be endorsed to contain, the following provisions:

1. General Liability and Automobile Liability Coverage

- a. The Agency, its officers, agents, employees and volunteers shall be named as an additional insured as regards negligence by the contractor. ISO Form CG 20 10 (current form approved for use in Louisiana), or equivalent, is to be used when applicable. The coverage shall contain no special limitations on the scope of protection afforded to the Agency.
- b. The Contractor's insurance shall be primary as respects the Agency, its officers, agents, employees and volunteers. Any insurance or self-insurance maintained by the Agency shall be excess and non-contributory of the Contractor's insurance.
- c. Any failure of the Contractor to comply with reporting provisions of the policy shall not affect coverage provided to the Agency, its officers, agents, employees and volunteers.
- d. The Contractor's insurance shall apply separately to each insured against whom claim is made or suit is brought, except with respect to the policy limits.

2. Workers Compensation and Employers Liability Coverage

The insurer shall agree to waive all rights of subrogation against the Agency, its officers, agents, employees and volunteers for losses arising from work performed by the Contractor for the Agency.

3. All Coverage

- a. Coverage shall not be canceled, suspended, or voided by either party (the Contractor or the insurer) or reduced in coverage or in limits except after 30 days written notice has been given to the Agency. Ten-day written notice of cancellation is acceptable for non-payment of premium. Notifications shall comply with the standard cancellation provisions in the Contractor's policy.
- b. Neither the acceptance of the completed work nor the payment thereof shall release the Contractor from the obligations of the insurance requirements or indemnification agreement.
- c. The insurance companies issuing the policies shall have no recourse against the Agency for payment of premiums or for assessments under any form of the policies.

- d. Any failure of the Contractor to comply with reporting provisions of the policy shall not affect coverage provided to the Agency, its officers, agents, employees and volunteers.

**D. ACCEPTABILITY OF INSURERS**

All required insurance shall be provided by a company or companies lawfully authorized to do business in the jurisdiction in which the Project is located. Insurance shall be placed with insurers with a A.M. Best's rating of **A-VI or higher**. This rating requirement may be waived for workers compensation coverage only.

If at any time an insurer issuing any such policy does not meet the minimum A.M. Best rating, the Contractor shall obtain a policy with an insurer that meets the A.M. Best rating and shall submit another Certificate of Insurance as required in the contract.

**E. VERIFICATION OF COVERAGE**

Contractor shall furnish the Agency with Certificates of insurance reflecting proof of required coverage. The Certificates for each insurance policy are to be signed by a person authorized by that insurer to bind coverage on its behalf. The Certificates are to be received and approved by the Agency before work commences and upon any contract renewal thereafter.

In addition to the Certificates, Contractor shall submit the declarations page and the cancellation provision endorsement for each insurance policy. The Agency reserves the right to request complete certified copies of all required insurance policies at any time.

Upon failure of the Contractor to furnish, deliver and maintain such insurance as above provided, this contract, at the election of the Agency, may be suspended, discontinued or terminated. Failure of the Contractor to purchase and/or maintain any required insurance shall not relieve the Contractor from any liability or indemnification under the contract.

**F. SUBCONTRACTORS**

Contractor shall include all subcontractors as insureds under its policies OR shall be responsible for verifying and maintaining the Certificates provided by each subcontractor. Subcontractors shall be subject to all of the requirements stated herein. The Agency reserves the right to request copies of subcontractor's Certificates at any time.

**G. WORKERS COMPENSATION INDEMNITY**

In the event Contractor is not required to provide or elects not to provide workers compensation coverage, the parties hereby agree that Contractor, its owners, agents and employees will have no cause of action against, and will not assert a claim against, the State of Louisiana, its departments, agencies, agents and employees as an employer, whether pursuant to the Louisiana Workers Compensation Act or otherwise, under any circumstance. The parties also hereby agree that the State of Louisiana, its departments, agencies, agents and employees shall in no circumstance be, or considered as, the employer or statutory employer of Contractor, its owners, agents and employees. The parties further agree that Contractor is a wholly independent contractor and is exclusively responsible for its employees, owners, and agents. Contractor hereby agrees to protect, defend, indemnify and hold the State of Louisiana, its departments, agencies, agents and employees harmless from any such assertion or claim that may arise from the performance of this contract.

***Maritime (Jones Act and LHWCA) needed when work is performed over navigable bodies of water***

**H. INDEMNIFICATION/HOLD HARMLESS AGREEMENT**

Contractor agrees to protect, defend, indemnify, save, and hold harmless, the State of Louisiana, all State Departments, Agencies, Boards and Commissions, its officers, agents, servants, employees, and volunteers, from and against any and all claims, damages, expenses, and liability arising out of injury or death to any person or the damage, loss or destruction of any property which may occur, or in any way grow out of, any act or omission of Contractor, its agents, servants, and employees, or any and all costs, expenses and/or attorney fees incurred by Contractor as a result of any claims, demands, suits or causes of action, except those claims, demands, suits, or causes of action arising out of the negligence of the State of Louisiana, all State Departments, Agencies, Boards, Commissions, its officers, agents, servants, employees and volunteers.

Contractor agrees to investigate, handle, respond to, provide defense for and defend any such claims, demands, suits, or causes of action at its sole expense and agrees to bear all other costs and expenses related thereto, even if the claims, demands, suits, or causes of action are groundless, false or fraudulent.

**NOTE: SUCCESSFUL BIDDER WILL BE REQUIRED TO PROVIDE A CERTIFICATE OF INSURANCE WITH SOUTHERN UNIVERSITY AS THE CERTIFICATE HOLDER  
SOUTHERN UNIVERSITY AND A&M COLLEGE  
PO BOX 9534  
BATON ROUGE, LA 70813  
225-771-4587**

# Restroom Renovations



Southern University A & M College  
129 Swan Street, Baton Rouge, Louisiana 70813



August 31, 2023

Domain Project No. C22-0072



8316 Kelwood Avenue, Baton Rouge, LA 70806  
Ph (225) 216-3770 / Fax (225) 216-3771

DOCUMENT 00010 – TABLE OF CONTENTS

00 00 01 - Cover page ..... 1  
00 00 10 - Table of Contents..... 2

BIDDING REQUIREMENTS

Bidding requirements, Bid Form, and other documents are provided by the Purchasing Dept. of SUBR

The following documents below are in this Project Manual -

00 20 00 - Instructions to Bidders..... 3

CONTRACT DOCUMENTS

General Conditions of the Contract for the Construction (AIA A201) included by reference ..... 1  
Supplementary Conditions of the Contract for Construction ..... 24

SPECIFICATIONS

Division 1 - General Requirements

Section 01 01 00 - Basic Requirements ..... 8  
Section 01 29 00 - Payment Procedures ..... 2  
Schedule of Values ..... 2  
Section 01 73 00 - Cutting and Patching ..... 3

Division 2 - Existing Conditions

Section 02 41 15 - Selective Demolition ..... 5  
02 80 00 - Abatement & Remediation  
02 80 10 Environmental Summary of Work ..... 16  
02 82 10 Removal of Asbestos Containing Materials ..... 16  
02 82 40 Disposal of Asbestos Containing Materials ..... 5  
02 83 19 Removal and Disposal of Lead-Containing Paint ..... 8  
02 84 30 Removal of PCP Containing Ballasts ..... 8  
02 85 00 Removal of Mercury Containing Light Tubes ..... 7

Division 3 - Concrete

03 30 00 Cast-In-Place-Concrete..... 14

Division 4 - Masonry

Section 04 27 00 - Masonry Assemblies..... 5

Division 6 - Wood, Plastics & Composites

Section 06 10 00 - Rough Carpentry ..... 3

Division 7 - Thermal and Moisture Protection

Section 07 90 00 - Sealants ..... 5

Division 8 - Openings

Section 08 11 13 - Metal Door Frames ..... 4



	Pages
Section 08 14 16 - Wood Doors .....	4
Section 08 71 00 - Door Hardware .....	7
Division 9 - Finishes	
Section 09 21 16 - Drywall Assemblies.....	5
Section 09 31 00 - Ceramic Tile .....	7
Section 09 51 00 - Acoustical Panel Ceiling System .....	4
Section 09 90 00 - Painting .....	6
Division 10 - Specialties	
Section 10 14 00 - Signage .....	3
Section 10 21 13 - Toilet Compartments .....	4
Section 10 28 00 - Toilet Accessories .....	5
Division 21 - Fire Suppression	
Section 21 00 00 – Fire Protection System.....	9
Section 21 13 13 – Wet-Pipe Sprinkler Systems .....	4
Division 22 - Plumbing	
Section 22 00 10 – Plumbing Piping (For projects in Louisiana) .....	10
Section 22 10 10 – Plumbing Specialties.....	4
Section 22 40 00 – Plumbing Fixtures .....	3
Division 23 - HVAC	
Section 23 00 00 - General Mechanical.....	6
Section 23 05 00 - Basic Materials and Methods, Mechanical .....	9
Section 23 05 13 – Motors.....	5
Section 23 05 29 – Supports and Anchors .....	3
Section 23 05 53 – Mechanical Identification.....	3
Section 23 05 93 – Testing, Adjusting and Balancing .....	5
Section 23 07 00 – Piping and Equipment Insulation.....	3
Section 23 31 00 – Ductwork.....	5
Section 23 34 10 – General Exhaust System .....	3
Section 23 37 00 – Air Outlets and Inlets.....	3
Division 26 - Electrical	
Section 26 01 00 - Basic Electrical Materials & Methods .....	10
Section 26 05 05 – Electrical Demolition .....	3
Section 26 05 50 – Basic Electrical Materials and Methods.....	8
Section 26 50 00 - Lighting .....	3

## DOCUMENT 00 20 00 - INSTRUCTIONS TO BIDDER

### 1.1 BID DOCUMENTS AND SECURING OF BID DOCUMENTS

- A. Digital set of Bid Documents are provided to an invited Prime Bidder.
- B. In developing the project bid, the Prime Bidder shall serve the interest of the Owner by obtaining competitive bids from subcontractors and material suppliers.

### 1.2 BID FORM

- A. Use the Bid Form provided by the Owner.
- B. Submit bid using the Bid Form provided, properly executed and with all items filled out. Do not change the wording of the Bid Form, and do not add words to the wording of the Bid Form. Unauthorized conditions, limitations, or provisions attached to the proposal shall be cause for rejection of the proposal. Alterations by erasure or interlineation must be explained or noted in the bid over the signature of the bidder.
- C. Deliver completed Bid Form and required attachments, properly addressed to the Owner on or before the date, time and address indicated in the Invitation to Bid.

### 1.3 BONDS

- A. Bid security is not required.
- B. Prior to signing the Contract, the Owner will require the Contractor to secure and post a Labor and Materials Payment Bond and a Performance Bond, each in the amount of 100% of the Contract Sum, and each on forms provided in the Project Manual. Bonds shall be issued by Sureties rated A-1 by A.M. Best, and as acceptable to the Owner. Include the costs of such bonds in the proposed Contract Sum.

### 1.4 EXAMINATION OF BID DOCUMENTS AND SITE OF WORK

- A. Before submitting a bid, each bidder shall carefully examine the Bid Documents, and visit the site of the work.
- B. Each bidder and sub-bidder shall be personally responsible for being fully informed prior to bidding as to existing conditions and limitations under which the work is to be performed, and each bidder shall include in the bid a sum to cover costs of all items required to perform the work as set forth in the Bid Documents.
- C. No allowance will be made to any bidder because of lack of such examination or knowledge. The submission of a bid will be construed as conclusive evidence that the bidder has made such examination.

### 1.5 EXECUTION OF AGREEMENT

- A. The form of Agreement which the successful prime bidder, as Contractor, will be required to execute will be provided by the Owner.

- B. The bidder to whom the Contract is awarded by the Owner shall, within 15 days after notice of award and receipt of Agreement forms from the Owner, sign and deliver to the Owner all required copies.
- C. At or prior to delivery of the signed Agreement, the Contractor shall deliver to the Owner the Labor and Materials Payment Bond, the Performance Bond, and the policies of insurance or insurance certificates as required by the Contract Documents. All bonds and policies of insurance shall be approved by the Owner before the successful bidder may proceed with the work.

#### 1.6 APPROVAL OF MATERIALS

- A. Materials entering into the construction of this project must conform to the requirements set forth herein.
- B. Substitute materials of equal quality to those specified will be considered and, if found satisfactory, will be approved by the Architect in an addendum to be issued to bidders prior to receipt of bids, provided representative samples or data on such materials are submitted to the Architect no later than 8 days before the date set for opening of proposals.
- C. The approval of substitute materials of equal quality to those specified shall not preclude the approval of materials equal to those specified after receipt of bids, and Contractors shall, therefore, quote on unapproved materials entirely at their own risk. Subcontractors and manufacturers are urged, wherever possible, to submit materials to the Architect for approval under the terms outlined above; failing to do so, they shall run the risk of having the material rejected.

#### 1.7 CONSTRUCTION TIME AND LIQUIDATED DAMAGES

- A. The Agreement will include a stipulation that the work be completed in a period stipulated in the construction documents following receipt of Notice to Proceed.
- B. The Agreement will also include a stipulation that liquidated damages will be established in the amount indicated in the construction documents, per calendar day for each calendar day after the completion date that the work is not fully completed, and a certificate of occupancy issued.

#### 1.8 TIME OF CONSTRUCTION AND NOTICE TO PROCEED

- A. The time period for construction is indicated in the construction documents.
- B. Notice to Proceed: It is anticipated that the Notice to Proceed will be issued as soon as possible after the award of the contract. The Contractor to whom the project is awarded shall be prepared to immediately begin work.

#### 1.9 CONTRACTOR'S LICENSE

- A. Primary contractors, subcontractors, and specialty contractors, whether engaged by the main contractor or by the Owner direct, must be qualified by the State Licensing Board for Contractors, State of Louisiana, as provided for under Act No. 233 of 1956, State of Louisiana. Only the bids of contractors and/or subcontractors meeting the requirements of this Act will be considered.

## 1.10 SUBMISSION OF POST-BID INFORMATION

- A. Upon request by the Owner and Architect, the bidder to whom the Contract is selected to be awarded shall within 7 days thereafter, submit the following:
1. A Schedule of Values indicating costs for each major item of work included in the bid.
  2. A list of names of the sub-contractors or other persons or organizations (including those who are to furnish materials or equipment fabricated to a special design) proposed for such portions of the work as may be designated, the names of the sub-contractors proposed for the principal portions of the work. The bidder will be required to establish to the satisfaction of the Architect and the Owner, the reliability and the responsibility of the proposed sub-contractors to furnish and perform the work described in the section of the specifications pertaining to such proposed sub-contractors respective trades. Prior to the award of the Contract, the Architect will notify the bidder in writing if either the Owner or the Architect, after due investigation, has reasonable and substantial objection to any person or organization on such list. If the Owner or Architect has a reasonable and substantial objection to any person or organization on such list, and refuses in writing to accept such person or organization, the bidder may, at the bidder's option, withdraw his/her bid without forfeiture of bid security. If the bidder submits an acceptable substitute with an increase in his/her bid price to cover the difference in cost occasioned by such substitution the Owner may, at the Owner's discretion, accept the increased bid price or the Owner may disqualify the bidder. Sub-contractors and other persons and organizations proposed by the bidder and accepted by the Owner and the Architect must be used on the work for which they were proposed and accepted, and shall not be changed except with the written approval of the Owner and the Architect.

End of Document 00 20 00 - Instructions to Bidders

# SUPPLEMENTARY CONDITIONS

These Supplementary Conditions modify, change, delete from or add to the General Conditions of the Contract for Construction, AIA Document A201, 2017 Edition. Where any Article of the General Conditions is modified or any Section, Paragraph, Subparagraph or Clause thereof is modified or deleted by these supplements, the unaltered provisions of that Section, Article, Paragraph, Subparagraph or Clause shall remain in effect.

Articles, Sections, Paragraphs, Subparagraphs or Clauses modified or deleted have the same numerical designation as those occurring in the General Conditions.

## ARTICLE 1

### GENERAL PROVISIONS

#### 1.1 BASIC DEFINITIONS

##### 1.1.1 The Contract Documents

In Section 1.1.1 delete the third sentence, and add the following sentence:

The Contract Documents shall include the Bid Documents as listed in the Instructions to Bidders and any modifications made thereto by addenda.

##### 1.1.8 Initial Decision Maker

Delete all after the words, “shall not show partiality to the Owner or Contractor”.

#### 1.5 OWNERSHIP AND USE OF DRAWINGS, SPECIFICATIONS AND OTHER INSTRUMENTS OF SERVICE [REFER TO *La R.S. 38:2317*]

1.5.1 Delete the first sentence of the paragraph.

1.5.1 In the third sentence: delete the remainder after the word “publication”.

#### 1.7 DIGITAL DATA USE AND TRANSMISSION

In the first sentence after the words, “in digital form” delete “. The parties will use AIA Document E203 2013, Building Information Modeling and Digital Data Exhibit”.

#### 1.8 BUILDING INFORMATION MODELS USE AND RELIANCE

Delete Section 1.8.

## ARTICLE 2

### OWNER

## **2.2 EVIDENCE OF THE OWNER'S FINANCIAL ARRANGEMENTS**

Delete Section 2.2.

## **2.3 INFORMATION AND SERVICES REQUIRED OF THE OWNER**

2.3.1 In the first sentence, delete: all before “the Owner shall secure...”

Delete Section 2.3.2 and substitute the following:

2.3.2 The term Architect, when used in the Contract Documents, shall mean the prime Designer (Architect, Engineer, or Landscape Architect), or his authorized representative, lawfully licensed to practice architecture, engineering, or landscape architecture in the State of Louisiana, identified as such in the Agreement and is referred to throughout the Contract Documents as if singular in number.

2.3.3 Delete the words: “to whom the Contractor has no reasonable objection and”.

## **ARTICLE 3**

### **CONTRACTOR**

## **3.4 LABOR AND MATERIALS**

3.4.2 Delete Section 3.4.2.

Delete Section 3.4.3 and substitute with the following:

3.4.3 Contractor and its employees, officers, agents, representatives, and Subcontractors shall conduct themselves in an appropriate and professional manner, in accordance with the Owner's requirements, at all times while working on the Project. Any such individual who behaves in an inappropriate manner or who engages in the use of inappropriate language or conduct while on Owner's property, as determined by the Owner, shall be removed from the Project at the Owner's request. Such individual shall not be permitted to return without the written permission of the Owner. The Owner shall not be responsible or liable to Contractor or any Subcontractor for any additional costs, expenses, losses, claims or damages incurred by Contractor or its Subcontractor as a result of the removal of an individual from the Owner's property pursuant to this Section. The Contractor shall not permit employment of unfit persons or persons not properly skilled in tasks assigned to them.

## **3.5 WARRANTY**

3.5.2 Replace reference to “Section 9.8.4” with “Section 9.8.6”.

### **3.7 PERMITS, FEES, NOTICES, AND COMPLIANCE WITH LAWS (La R.S. 40:1724[A])**

3.7.1 Delete Section 3.7.1.

3.7.2 In Section 3.7.2, replace the word “public” with the word “State”.

Delete Section 3.7.5 and substitute the following:

3.7.5 If, during the course of the Work, the Contractor discovers human remains, unmarked burial or archaeological sites, burial artifacts, or wetlands, which are not indicated in the Contract Documents, the Contractor shall follow all procedures mandated by State and Federal law, including but not limited to La R.S. 8:671 et seq., the Office of Coastal Protection and Restoration, and Sections 401 & 404 of the Federal Clean Water Act. Request for adjustment of the Contract Sum and Contract Time arising from the existence of such remains or features shall be submitted in writing to the Owner pursuant to the Contract Documents.

### **3.8 ALLOWANCES**

Delete Sections 3.8.1, 3.8.2, and 3.8.3 in their entirety and add the following new Section 3.8.1:

3.8.1 Allowances shall not be made on any of the Work.

### **3.9 SUPERINTENDENT**

3.9.1 Add the following to the end of the paragraph:  
Important communications shall be confirmed in writing. Other communications shall be similarly confirmed on written request in each case.

### **3.10 CONTRACTOR’S CONSTRUCTION AND SUBMITTAL SCHEDULES**

3.10.1 Add the following: For projects with a contract sum greater than \$1,000,000.00, the Contractor shall include with the schedule, for the Owner’s and Architect’s information, a network analysis to identify those tasks which are on the critical path, i.e., where any delay in the completion of these tasks will lengthen the project timescale, unless action is taken. A revised schedule shall be submitted with each Application and Certificate for Payment. No payment shall be made until this schedule is received.

3.10.3 In the first sentence, delete the word “general”.

After the first sentence, add the following:

If the Work is not on schedule, as determined by the Architect, and the Contractor fails to take action to bring the Work on schedule, then the Contractor shall be deemed in default under this Contract and the progress of the Work shall be deemed unsatisfactory. Such default may be considered grounds for termination by the Owner for cause in accordance with Section 14.2.

Add the following Sections:

- 3.10.4 Add the following: Submittal by the contractor of a schedule or other documentation showing a completion date for his Work prior to the completion date stated in the contract shall not impose any obligation or responsibility on the Owner or Architect for the earlier completion date.
- 3.10.5 In the event the Owner employs a commissioning consultant, the Contractor shall cooperate fully in the commissioning process and shall require all subcontractors and others under his control to cooperate. The purpose of such services shall be to ensure that all systems perform correctly and interactively according to the provisions of the Contract Documents.

### **3.11 DOCUMENTS AND SAMPLES AT THE SITE**

Add the following: This requirement is of the essence of the contract. The Architect shall determine the value of these documents and this amount shall not be approved for payment to the Contractor until all of the listed documents are delivered to the Architect in good order, completely marked with field changes and otherwise complete in all aspects.

## **ARTICLE 4**

### **ARCHITECT**

#### **4.2 ADMINISTRATION OF THE CONTRACT**

- 4.2.1 In the first sentence, delete the phrase: “the date the Architect issues the final Certificate for Payment” and replace with the phrase “final payment is due, and with the Owner’s concurrence, from time to time during the one year period for correction of Work described in Section 12.2.”
- 4.2.2 In the first sentence, after the phrase: “become generally familiar with”; insert the following: “and to keep the Owner informed about”.
- In the first sentence, after the phrase “portion of the Work completed”, insert the following: “to endeavor to guard the Owner against defects and deficiencies in the Work,”
- 4.2.4 In the first sentence, delete all after “The Owner and Contractor”, and add the following “may communicate directly with each other, when deemed necessary by the Owner, and the Owner will notify the Architect of any decision.”
- 4.2.10 Add the following sentence to the end of Section 4.2.10: There shall be no restriction on the Owner having a Representative.
- 4.2.11 Add the following sentence to the end of Section 4.2.11:

If no agreement is made concerning the time within which interpretation required of the Architect shall be furnished in compliance with this Section 4.2, then delay shall not be



recognized on account of failure by the Architect to furnish such interpretation until 15 days after written request is made for them.

4.2.14 Insert the following sentence between the second and third sentences of Section 4.2.14:

If no agreement is made concerning the time within which interpretation required of the Architect shall be furnished in compliance with this Section 4.2, then delay shall not be recognized on account of failure by the Architect to furnish such interpretation until 15 days after written request is made for them.

## **ARTICLE 5**

### **SUBCONTRACTORS**

#### **5.2 AWARD OF SUBCONTRACTS AND OTHER CONTRACTS FOR PORTIONS OF THE WORK**

Delete Section 5.2.1, and substitute the following:

5.2.1 Unless otherwise required by the Contract Documents, the Contractor shall furnish at the Pre-Construction Conference, to the Owner and the Architect, in writing, the names of the persons or entities (including those who are to furnish materials or equipment fabricated to a special design) proposed for each of the principal portions of the Work. No Contractor payments shall be made until this information is received.

Delete Section 5.2.2, and substitute the following:

5.2.2 The Contractor shall be solely responsible for selection and performance of all subcontractors. The Contractor shall not be entitled to claims for additional time and/or an increase in the contract sum due to a problem with performance or nonperformance of a subcontractor.

Delete Sections 5.2.3 and 5.2.4 and substitute the following:

5.2.3 The Contractor shall notify the Architect and the Owner when a subcontractor is to be changed and substituted with another subcontractor.

#### **5.4 CONTINGENT ASSIGNMENT OF SUBCONTRACTS**

Delete Sections 5.4, 5.4.1, 5.4.2 and 5.4.3

## **ARTICLE 7**

### **CHANGES IN THE WORK**

#### **7.1 GENERAL**

Add the following Sections:

- 7.1.4 As part of the pre-construction conference submittals, the Contractor shall submit the following prior to the Contractor's initial request for payment:
  - 7.1.4.1 Fixed job site overhead cost itemized with documentation to support daily rates.
  - 7.1.4.2 Bond Premium Rate with supporting information from the General Contractor's carrier.
  - 7.1.4.3 Labor Burden by trade for both Subcontractors and General Contractor. The Labor Burden shall be supported by the Worker's Compensation and Employer's Liability Insurance Policy Information Page. Provide for all trades.
  - 7.1.4.4 Internal Rate Charges for all significant company owned equipment.
- 7.1.5 If the General Contractor fails to submit the aforementioned documentation as part of the pre-construction submittals, then pay applications shall not be processed until such time as the Owner receives this information.

## 7.2 CHANGE ORDERS

Delete Section 7.2.1, and substitute the following Sections:

- 7.2.1 A Change Order is a written instrument prepared by the Architect and signed by the Owner, the Architect, and the Contractor issued after execution of the Contract, authorizing a change in the Work and/or an adjustment in the Contract Sum and/or the Contract Time. The Contract Sum and the Contract Time may be changed only by Change Order. A Change Order signed by the Contractor indicates his agreement therewith, including the adjustment in the Contract Sum or the Contract Time. Any reservation of rights, stipulation, or other modification made on the change order by the contractor shall have no effect.
- 7.2.2 "Cost of the Work" for the purpose of Change Orders shall be the eligible costs required to be incurred in performance of the Work and paid by the Contractor and Subcontractors which eligible costs shall be limited to:
  - 7.2.2.1 Actual wages paid directly to labor personnel, with a labor burden markup exclusively limited to applicable payroll taxes, worker's compensation insurance, unemployment compensation, and social security taxes for those labor personnel performing the Work. Wages shall be the basic hourly labor rate paid an employee exclusive of fringe benefits or other employee costs. The labor burden percentage for the "Cost of the Work" is limited to categories listed herein. Employer-provided health insurance, fringe benefits, employee training (whether a requirement of employment or not), vacation pay, etc., are examples of ineligible labor burden costs which **shall not** be included, as these costs are already compensated by the Overhead and Profit markup.

Supervision shall not be included as a line item in the “Cost of the Work”, except when the change results in a documented delay in the critical path, as described in Section 7.2.7.

7.2.2.2 Cost of all materials and supplies necessary and required to perform the Work, identifying each item and its individual cost, including taxes. Incidental consumables are not eligible costs and shall not be included.

7.2.2.3 Cost of each necessary piece of machinery and equipment required to perform the Work, identifying each item and its individual cost, including taxes. Incidental small tools of a specific trade (i.e., shovels, saws, hammers, air compressors, etc.,) and general use vehicles, such as pickup trucks even for moving items around the site, fuel for these general use vehicles, travel, lodging, and/or meals are not eligible and shall not be included.

7.2.2.4 Eligible Insurance costs shall be limited to documented increases in “Builder’s Risk” insurance premium / costs only. Commercial General Liability, Automobile Liability, and all other required insurances, where referenced in the Contract shall be considered part of normal overhead. These costs are already compensated by the Overhead and Profit markup.

7.2.2.5 Cost for the General Contractor Performance and Payment Bond premium, where the documented cost of the premiums have been increased due to the Change Order.

7.2.3 Overhead and Profit - The Contractor and Subcontractor shall be due home office fixed overhead and profits on the Cost of the Work, but shall not exceed a total of 16% of the direct cost of any portion of Work.

The credit to the Owner resulting from a change in the Work shall be the sum of those items above, except credit will not be required for Overhead and Profit. Where a change results in both credits to the Owner and extras to the Contractor for related items, overhead and profit shall only be computed on the net extra cost to the Contractor.

7.2.4 The cost to the Owner resulting from a change in the Work shall be the sum of: Cost of the Work (as defined at Section 7.2.2) and Overhead and Profit (as defined at Section 7.2.3), and shall be computed as follows:

7.2.4.1 When all of the Work is General Contractor Work; 8% markup on the Cost of the Work.

7.2.4.2 When the Work is all Subcontract Work; 8% markup on the Cost of the Work for Subcontractor’s Overhead and Profit, plus 8% markup on the Cost of the Work, not including the Subcontractor’s Overhead and Profit markup, for General Contractor’s Overhead and Profit.

7.2.4.3 When the Work is a combination of General Contractor Work and Subcontract Work; that portion of the direct cost that is General Contract Work shall be computed per Section 7.2.4.1 and that portion of the direct cost that is Subcontract Work shall be computed per Section 7.2.4.2.

Premiums for the General Contractor's bond may be included, but after the markup is added to the Cost of the Work.  
Premiums for the Subcontractor's Bond shall not be included.

7.2.4.4 Subcontract cost shall consist of the items in Section 7.2.2 above plus Overhead and Profit as defined in Section 7.2.3.

7.2.5 Before a Change Order is prepared, the Contractor shall prepare and deliver to the Architect the following information concerning the Cost of the Work, not subject to waiver, within a reasonable time after being notified to prepare said Change Order:

A detailed, itemized list of labor, material and equipment costs for the General Contractor's Work including quantities and unit costs for each item of labor, material and equipment.

An itemized list of labor, material and equipment costs for each Subcontractor's and/or Sub-Subcontractor's Work including quantities and unit costs for each item of labor, material and equipment.

7.2.6 After a Change Order has been approved, no future requests for extensions of time or additional cost shall be considered for that Change Order.

7.2.7 Extended fixed job-site costs are indirect costs that are necessary to support the work in the field. Examples of fixed job-site costs are field office rental, salaries of field office staff, field office utilities and telephone.

Extended fixed job-site costs or equitable adjustment, may be included in a Change Order due to a delay in the critical path, with the exception of weather related delays. In the event of a delay in the critical path, the Contractor shall submit all changes or adjustments to the Contract Time **within twenty-one (21) days** of the event giving rise to the delay. The Contractor shall submit documentation and justification for the adjustment by performing a critical path analysis of its most recent schedule in use prior to the change, which shows an extension in critical path activities.

The Contractor shall notify the Architect in writing that the Contractor is making a claim for extended fixed job-site overhead as required by Section 15.1.2. The Contractor shall provide proof that the Contractor is unable to mitigate financial damages through Alternate Work within this Contract or replacement work. "Replacement Work" is that work which the Contractor is obligated to perform under any construction contract separate from this Contract. Reasonable proof shall be required by the Architect that the delays affected the Completion Date.

7.2.8 "Cost of the Work" whether General Contractor cost or Subcontractor cost shall not apply to the following:

7.2.8.1 Salaries or other compensation of the Contractor's personnel at the Contractor's principal office and branch offices.

- 7.2.8.2 Any part of the Contractor's capital expenses, including interest on the Contractor's capital employed for the Work.
- 7.2.8.3 Overhead and general expenses of any kind or the cost of any item not specifically and expressly included above in Cost of the Work.
- 7.2.8.4 Cost of supervision, refer to section 7.2.2.1, with exception as provided in Section 7.2.7.
- 7.2.9 When applicable as provided by the Contract, the cost to Owner for Change Orders shall be determined by quantities and unit prices. The quantity of any item shall be as submitted by the Contractor and approved by the Architect. Unit prices shall cover cost of Material, Labor, Equipment, Overhead and Profit.

**7.3 CONSTRUCTION CHANGE DIRECTIVES**

- 7.3.3 In the first sentence after "following methods" insert: ", but not to exceed a specified amount".
- 7.3.4 From .1 of the list, delete all after "Costs of labor, including" and substitute the following "social security, old age and employment insurance, applicable payroll taxes, and workers' compensation insurance;"

Delete the following from .4 of the list: "permit fees,"

Delete Section 7.3.9 and substitute the following:

- 7.3.9 Pending final determination of the total costs of a Construction Change Directive to the Owner, amounts not in dispute for such changes in the Work shall be included in Applications for Payment accompanied by a Change Order indicating the parties' agreement with part or all of such costs.

**ARTICLE 8**

**TIME**

**8.1 DEFINITIONS**

Add the following:

- 8.1.5 The Contract Time shall not be changed by the submission of a schedule that shows an early completion date unless specifically authorized by change order.

**8.2 PROGRESS AND COMPLETION**

Add to Section 8.2.1 the following:

Completion of the Work must be within the Time for Completion stated in the Agreement, subject to such extensions as may be granted under Section 8.3. The Contractor agrees to

commence Work not later than fourteen (14) days after the transmittal date of Written Notice to Proceed from the Owner and to substantially complete the project within the time stated in the Contract. The Owner will suffer financial loss if the project is not substantially complete in the time set forth in the Contract Documents. The Contractor and the Contractor's Surety shall be liable for and shall pay to the Owner the sum stated in the Contract Documents as fixed, agreed and liquidated damages for each consecutive calendar day (Saturdays, Sundays and holidays included) of delay until the Work is substantially complete. The Owner shall be entitled to the sum stated in the Contract Documents. Such Liquidated Damages shall be withheld by the Owner from the amounts due the Contractor for progress payments.

Delete Section 8.2.2.

### **8.3 DELAYS AND EXTENSIONS OF TIME**

8.3.1 In the first sentence after the words "Owner pending" delete the words "mediation and binding dispute resolution" and add the word "litigation", and delete the last word "determine" and add the following: "recommend, subject to Owner's approval of Change Order. If the claim is not made within the limits of Article 15, all rights for future claims for that month are waived."

## **ARTICLE 9**

### **PAYMENTS AND COMPLETION**

#### **9.1 CONTRACT SUM**

Delete Section 9.1.2.

Delete Section 9.2 and substitute the following:

#### **9.2 SCHEDULE OF VALUES**

At the Pre-Construction Conference, the Contractor shall submit to the Owner and the Architect a Schedule of Values prepared as follows:

9.2.1 The attached Schedule of Values Format shall be used. If applicable, the cost of Work for each section listed under each division, shall be given. The cost for each section shall include Labor, Materials, Overhead and Profit.

9.2.2 The Total of all items shall equal the Total Contract Sum. This schedule, when approved by the Architect, shall be used as a basis for the Contractor's Applications for Payment and it may be used for determining the cost of the Work in deductive change orders, when a specific item of Work listed on the Schedule of Values is to be removed. Once the Schedule of Values is submitted at the Pre-Construction Conference, the schedule shall not be modified without approval from the Owner and Architect.

#### **9.3 APPLICATIONS FOR PAYMENT**

Delete Sections 9.3.1, 9.3.1.1, and 9.3.1.2 and substitute the following:

9.3.1 Monthly, the Contractor shall submit to the Architect an Application & Certificate for Payment on the AIA Document G702-1992, accompanied by AIA Document G703-1992, and supported by any additional data substantiating the Contractor's right to payment as the Owner or the Architect may require. Application for Payment shall be submitted on or about the first of each month for the value of labor and materials incorporated into the Work and of materials, suitably stored, at the site as of the twenty-fifth day of the preceding month, less normal retainage as follows, per La R.S. 38:2248:

9.3.1.1 Projects with Contract price up to \$500,000.00 – 10% of the Contract price.

9.3.1.2 Projects with Contract price of \$500,000.00, or more – 5% of the Contract price.

9.3.1.3 No payment shall be made until the revised schedule required by Section 3.10.1 is received.

9.3.1.4 The normal retainage shall not be due the Contractor until after substantial completion and expiration of the forty-five day lien period and submission to the Architect of a clear lien certificate, consent of surety, and invoice for retainage.

Delete Section 9.3.2 and substitute the following:

9.3.2 Unless otherwise provided in the Contract Documents, payments shall be made on account of materials and equipment delivered and suitably stored at the site for subsequent incorporation in the Work. Payments for materials or equipment stored on the site shall be conditioned upon submission by the Contractor of bills of sale or such other procedures satisfactory to the Owner to establish the Owner's title to such materials and equipment or otherwise protect the Owner's interest, including applicable insurance.

## **9.5 DECISIONS TO WITHHOLD CERTIFICATION**

Section 9.5.1.7: Delete the word "repeated".

Delete Section 9.5.4.

## **9.6 PROGRESS PAYMENTS**

Delete Section 9.6.1 and substitute the following:

9.6.1 After the Architect has issued a Certificate for Payment, the Owner shall make payment within twenty days except for projects funded fully or in part by a Federal reimbursement program. For such projects the Owner will make payment in a timely manner consistent with reimbursement.

9.6.2 Delete the phrase: "no later than seven days" from the first sentence.

After the end of the second sentence, add the following:

La R.S. 9:2784 (A) and (C) require a Contractor or Subcontractor to make payment due to each Subcontractor and supplier within fourteen (14) consecutive days of the receipt of payment from the Owner. If not paid, a penalty in the amount of ½ of 1% per day is due, up to a maximum of 15% from the expiration date until paid. The contractor or subcontractor, whichever is applicable, is solely responsible for payment of a penalty.

- 9.6.4 Delete the first two sentences of Section 9.6.4 and add the following to the end of the Section:

Pursuant to La. R.S. 38:2242 and La. R.S. 38:2242.2, when the Owner receives any claim of nonpayment arising out of the Contract, the Owner shall deduct 125% of such claim from the Contract Sum. The Contractor, or any interested party, may deposit security, in accordance with La. R.S. 38:2242.2, guaranteeing payment of the claim with the recorder of mortgages of the parish where the Work has been done. When the Owner receives original proof of such guarantee from the recorder of mortgages, the claim deduction will be added back to the Contract Sum.

Delete Section **9.7 FAILURE OF PAYMENT**.

Delete Section 9.8 and substitute the following:

## **9.8 SUBSTANTIAL COMPLETION**

- 9.8.1 Substantial Completion is the stage in the progress of the Work when the Work is sufficiently complete in accordance with the Contract Documents so that the Owner can occupy or utilize the Work for its intended use. The Architect shall determine if the project is substantially complete in accordance with this Section.
- 9.8.2 When the Contractor considers that the Work is Substantially Complete, the Contractor shall prepare and submit to the Architect a comprehensive list of items to be completed or corrected prior to final payment. Failure to include an item on such list does not alter the responsibility of the Contractor to complete all Work in accordance with the Contract Documents.
- 9.8.3 Upon receipt of the Contractor's list, the Architect shall make an inspection to determine whether the Work is substantially complete. A prerequisite to the Work being considered as substantially complete is the Owner's receipt of the executed Roofing Contractor's and Roofing Manufacturer's guarantees, where roofing Work is part of the Contract. Prior to inspection by the Architect, the Contractor shall notify the Architect that the project is ready for inspection by the State Fire Marshal's office. If the Architect's inspection discloses any item, whether or not included on the Contractor's list, which is not sufficiently complete in accordance with the Contract Documents so that the Owner can occupy or utilize the Work for its intended use, the Contractor shall, before the Work can be considered as Substantially Complete, complete or correct such item upon notification by the Architect. In such case, the Contractor shall then submit a request for another inspection by the Architect to determine Substantial Completion.
- 9.8.4 When the Architect determines that the project is Substantially Complete, he shall prepare a punch list of exceptions and the dollar value related thereto. The monetary value assigned to this list will be the sum of the cost estimate for each particular item of



Work the Architect develops based on the mobilization, labor, material and equipment costs of correcting the item and shall be retained from the monies owed the contractor, above and beyond the standard lien retainage. The cost of these items shall be prepared in the same format as the schedule of values. At the end of the forty-five day lien period payment shall be approved for all punch list items completed up to that time. After that payment, none of the remaining funds shall be due the contractor until all punch list items are completed and are accepted by the Architect. If the dollar value of the punch list exceeds the amount of funds, less the retainage amount, in the remaining balance of the Contract, then the Project shall not be considered as substantially complete. If funds remaining are less than that required to complete the Work, the Contractor shall pay the difference.

- 9.8.5 When the preparation of the punch list is complete the Architect shall prepare a Recommendation of Acceptance incorporating the punch list and submit it to the Owner. Upon approval of the Recommendation of Acceptance, the Owner may issue a Notice of Acceptance of Building Contract which shall establish the Date of Substantial Completion. The Contractor shall record the Notice of Acceptance with the Clerk of Court in the Parish in which the Work has been performed. If the Notice of Acceptance has not been recorded seven (7) days after issuance, the Owner may record the Acceptance at the Contractor's expense. All additive change orders must be processed before issuance of the Recommendation of Acceptance. The Owner shall not be responsible for payment for any Work associated with change orders that is not incorporated into the contract at the time of the Recommendation of Acceptance.
- 9.8.6 Warranties required by the Contract Documents shall commence on the date of Acceptance of the Work unless otherwise agreed to in writing by the Owner and Contractor. Unless otherwise agreed to in writing by the Owner and Contractor, security, maintenance, heat, utilities, damage to the Work not covered by the punch list and insurance shall become the Owner's responsibility on the Date of Substantial Completion.
- 9.8.7 If all punch list items have not been completed by the end of the forty-five (45) day lien period, through no fault of the Architect or Owner, the Owner may hold the Contractor in default. If the Owner finds the Contractor is in default, the Surety shall be notified. If within forty-five (45) days after notification, the Surety has not completed the punch list, through no fault of the Architect or Owner, the Owner may, at his option, contract to have the balance of the Work completed and pay for such Work with the unpaid funds remaining in the Contract sum. Finding the Contractor in default shall constitute a reason for disqualification of the Contractor from bidding on future state contracts. If the surety fails to complete the punch list within the stipulated time period, the Owner may not accept bonds submitted, in the future, by the surety.

## **9.9 PARTIAL OCCUPANCY OR USE**

Delete Section 9.9.1 and substitute the following:

- 9.9.1 Partial Occupancy is that stage in the progress of the Work when a designated portion of the Work is sufficiently complete in accordance with the Contract Documents so the Owner can occupy or utilize the designated portion of the Work for its intended use. The Owner may occupy or use any substantially completed portion of the Work so designated

by separate agreement with the Contractor and authorized by public authorities having jurisdiction over the Work. Such occupancy or use may commence provided the Owner and Contractor have accepted in writing the responsibilities assigned to each of them for payments, if any, security, maintenance, heat, utilities, damage to the Work and insurance, and have agreed in writing concerning the period for correction of the Work and commencement of warranties required by the Contract Documents. When the Contractor considers the designated portion substantially complete the Contractor shall prepare and submit a list to the Architect as provided under Section 9.8.2. Consent of the Contractor to partial occupancy or use shall not be unreasonably withheld.

## **9.10 FINAL COMPLETION AND FINAL PAYMENT**

9.10.1 After the second sentence, add the following:

If the Architect does not find the Work acceptable under the Contract Documents, the Architect shall make one additional inspection; if the Work is still not acceptable, the Architect, and each of the Architect's principal consultants, shall be paid \$175.00/hour for their time at the project site, for each additional inspection, to be withheld from the unpaid funds remaining in the Contract sum. The payment shall be made by the Owner and deducted from the construction contract funds.

Delete Section 9.10.4 and replace with the following:

9.10.4 The making of final payment shall not constitute a waiver of Claims by the Owner for the following:

9.10.4.1 Claims, security interests, or encumbrances arising out of the Contract and unsettled;

9.10.4.2 failure of the Work to comply with the requirements of the Contract Documents irrespective of when such failure is discovered;

9.10.4.3 terms of special warranties required by the Contract Documents; or

9.10.4.4 audits performed by the Owner, after final payment.

## **ARTICLE 10**

### **PROTECTION OF PERSONS AND PROPERTY**

#### **10.2 SAFETY OF PERSONS AND PROPERTY**

10.2.2 In the first sentence, between the words: "bearing on" and "safety", add the words: "the health and,"

#### **10.3 HAZARDOUS MATERIALS**

10.3.1 In the second sentence after (PCB) add: "or lead".

10.3.2 After the first sentence, delete all remaining sentences.

Add at the end: "The Contract time shall be extended appropriately."

Delete Section 10.4 and substitute the following:

#### **10.4 EMERGENCIES**

In an emergency affecting the safety of persons or property, the Contractor shall notify the Owner and Architect immediately of the emergency, simultaneously acting at his discretion to prevent damage, injury or loss. Any additional compensation or extension of time claimed by the Contractor on account of emergency Work shall be determined as provided in Article 15 and Article 7.

### **ARTICLE 11**

#### **INSURANCE AND BONDS**

**AIA A101 – 2017 Exhibit A is not a part of these documents. Delete all of Sections 11.1, 11.2, 11.3, 11.4, and 11.5, and substitute the following:**

#### **INSURANCE REQUIREMENTS FOR NEW CONSTRUCTION, ADDITIONS AND RENOVATIONS**

##### **11.1 CONTRACTOR'S LIABILITY INSURANCE**

The Contractor shall purchase and maintain without interruption for the duration of the contract insurance against claims for injuries to persons or damages to property which may arise from or in connection with the performance of the Work hereunder by the Contractor, its agents, representatives, employees or subcontractors. The duration of the contract shall be from the inception of the contract until the date of final payment.

##### **11.2 MINIMUM SCOPE AND LIMITS OF INSURANCE**

###### **11.2.1 Worker's Compensation**

Worker's Compensation insurance shall be in compliance with the Worker's Compensation law of the Contractor's headquarters. Employers Liability is included with a minimum limit of \$1,000,000 per accident/per disease/per employee. If Work is to be performed over water and involves maritime exposure, applicable LHWCA, Jones Act or other maritime law coverage shall be included. A.M. Best's insurance company rating requirement may be waived for Worker's compensation coverage only.

###### **11.2.2 Commercial General Liability**

Commercial General Liability insurance, including Personal and Advertising Injury Liability and Products and Completed Operations Liability, shall have a minimum limit per occurrence based on the project value. The Insurance Services Office (ISO) Commercial General Liability occurrence coverage form CG 00 01 (current form approved for use in Louisiana), or equivalent, is to be used in the policy. Claims-made form is unacceptable.

The aggregate loss limit must apply to each project. ISO form CG 25 03 (current form approved for use in Louisiana), or equivalent, shall also be submitted. The State project number, including part number, and project name shall be included on this endorsement.

**COMBINED SINGLE LIMIT (CSL) PER OCCURRENCE**

<b>Type of Construction</b>	<b>Projects up to \$1,000,000</b>	<b>Projects over \$1,000,000 up to \$10,000,000</b>	<b>Projects over \$10,000,000</b>
<b>New Buildings:</b>			
Each Occurrence Minimum Limit	\$1,000,000	\$2,000,000	\$4,000,000
Per Project Aggregate	\$2,000,000	\$4,000,000	\$8,000,000
<b>Renovations: The building(s) value for the Project is \$_____.</b>			
Each Occurrence Minimum Limit	\$1,000,000**	\$2,000,000**	\$4,000,000**
Per Project Aggregate	2 times per occur limit**	2 times per occur limit**	2 times per occur limit**

\*\*While the minimum Combined Single Limit of \$1,000,000 is required for any renovation, the limit is calculated by taking 10% of the building value and rounding it to the nearest \$1,000,000 to get the insurance limit. Example: Renovation on a \$33,000,000 building would have a calculated \$3,300,000 combined single limit of coverage (33,000,000 times .10 = 3,300,000 and then rounding down to \$3,000,000). If the calculated limit is less than the minimum limit listed in the above chart, then the amount needed is the minimum listed in the chart. Maximum per occurrence limit required is \$10,000,000 regardless of building value. The per project aggregate limit is then calculated as twice the per occurrence limit.

11.2.3 Automobile Liability

Automobile Liability Insurance shall have a minimum combined single limit per occurrence of \$1,000,000. ISO form number CA 00 01 (current form approved for use in Louisiana), or equivalent, is to be used in the policy. This insurance shall include third-party bodily injury and property damage liability for owned, hired and non-owned automobiles.

11.2.4 Excess Umbrella

Excess Umbrella Insurance may be used to meet the minimum requirements for General Liability and Automobile Liability only.

11.2.5 Builder's Risk

- 11.2.5.1 Builder's Risk Insurance shall be in an amount equal to the amount of the construction contract including any amendments and shall be upon the entire Work included in the contract. The policy shall provide coverage equivalent to the ISO form number CP 10 20, Broad Form Causes of Loss (extended, if necessary, to include the perils of wind, earthquake, collapse, vandalism/malicious mischief, and theft, including theft of materials whether or not attached to any structure). The policy must include architects' and engineers' fees necessary to provide plans, specifications and supervision of Work for the repair and/or replacement of property damage caused by a covered peril, not to exceed 10% of the cost of the repair and/or replacement.
- 11.2.5.2 Flood coverage shall be provided by the Contractor on the first floor and below for all projects, except as otherwise noted. The builder's risk insurance policy, sub-limit for flood coverage shall not be less than ten percent (10%) of the total contract cost per occurrence. If flood is purchased as a separate policy, the limit shall be ten percent (10%) of the total contract cost per occurrence (with a max of \$500,000 if NFIP). Coverage for roofing projects shall **not** require flood coverage.
- 11.2.5.3 A Specialty Contractor may provide an installation floater in lieu of a Builder's Risk policy, with the similar coverage as the Builder's Risk policy, upon the system to be installed in an amount equal to the amount of the contract including any amendments. Flood coverage is not required.
- 11.2.5.4 The policy must include coverage for the Owner, Contractor and any subcontractors as their interests may appear.
- 11.2.6 Pollution Liability (*required when asbestos or other hazardous material abatement is included in the contract*)

Pollution Liability insurance, including gradual release as well as sudden and accidental, shall have a minimum limit of not less than \$1,000,000 per claim. A claims-made form will be acceptable. A policy period inception date of no later than the first day of anticipated Work under this contract and an expiration date of no earlier than 30 days after anticipated completion of all Work under the contract shall be provided. There shall be an extended reporting period of at least 24 months, with full reinstatement of limits, from the expiration date of the policy if the policy is not renewed. The policy shall not be cancelled for any reason, except non-payment of premium.

#### 11.2.7 Deductibles and Self-Insured Retentions

Any deductibles or self-insured retentions must be declared to and accepted by the Owner. The Contractor shall be responsible for all deductibles and self-insured retentions.

### 11.3 OTHER INSURANCE PROVISIONS

11.3.1 The policies are to contain, or be endorsed to contain, the following provisions:

11.3.1.1 Worker's Compensation and Employers Liability Coverage

11.3.1.1.1 To the fullest allowed by law, the insurer shall agree to waive all rights of subrogation against the Owner, its officers, agents, employees and volunteers for losses arising from Work performed by the Contractor for the Owner.

#### 11.3.1.2 Commercial General Liability Coverage

11.3.1.2.1 The Owner, its officers, agents, employees and volunteers are to be added as additional insureds as respects liability arising out of activities performed by or on behalf of the Contractor; products and completed operations of the Contractor, premises owned, occupied or used by the Contractor. ISO Form CG 20 10 (for ongoing work) AND CG 20 37 (for completed work) (current forms approved for use in Louisiana), or equivalent, are to be used.

11.3.1.2.2 The Contractor's insurance shall be primary as respects the Owner, its officers, agents, employees and volunteers for any and all losses that occur under the contract. The coverage shall contain no special limitations on the scope of protection afforded to the Owner, its officers, officials, employees or volunteers. Any insurance or self-insurance maintained by the Owner shall be excess and non-contributory of the Contractor's insurance.

#### 11.3.1.3 Builder's Risk

The policy must include an endorsement providing the following:

In the event of a disagreement regarding a loss covered by this policy, which may also be covered by a State of Louisiana self-insurance or commercial property policy through the Office of Risk Management (ORM), Contractor and its insurer agree to follow the following procedure to establish coverage and/or the amount of loss:

Any party to a loss may make written demand for an appraisal of the matter in disagreement. Within 20 days of receipt of written demand, the Contractor's insurer and either ORM or its commercial insurance company shall each select a competent and impartial appraiser and notify the other of the appraiser selected. The two appraisers shall select a competent and impartial umpire. The appraisers shall then identify the policy or policies under which the loss is insured and, if necessary, state separately the value of the property and the amount of the loss that must be borne by each policy. If the two appraisers fail to agree, they shall submit their differences to the umpire. A written decision by any two shall determine the policy or policies and the amount of the loss. Each insurance company agrees that the decision of the appraisers and the umpire if involved shall be binding and final and that neither party will resort to litigation. Each of the two parties shall pay its chosen appraiser and bear the cost of the umpire equally.

#### 11.3.1.4 All Coverages

- 11.3.1.4.1 All policies must be endorsed to require 30 days written notice of cancellation to the Agency. Ten-day written notice of cancellation is acceptable for non-payment of premium. Notifications shall comply with the standard cancellation provisions in the Contractor's policy. In addition, Contractor is required to notify Agency of policy cancellations or reductions in limits.
- 11.3.1.4.2 Neither the acceptance of the completed Work nor the payment thereof shall release the Contractor from the obligations of the insurance requirements or indemnification agreement.
- 11.3.1.4.3 The insurance companies issuing the policies shall have no recourse against the Owner for payment of premiums or for assessments under any form of the policies.
- 11.3.1.4.4 Any failure of the Contractor to comply with reporting provisions of the policy shall not affect coverage provided to the Owner, its officers, agents, employees and volunteers.

11.3.2 Acceptability of Insurers

All required insurance shall be provided by a company or companies lawfully authorized to do business in the jurisdiction in which the Project is located. Insurance shall be placed with insurers with an A.M. Best's rating of **A-: VI or higher**. This rating requirement may be waived for Worker's compensation coverage only.

If at any time an insurer issuing any such policy does not meet the minimum A.M. Best rating, the Contractor shall obtain a policy with an insurer that meets the A.M. Best rating and shall submit another certificate of insurance within 30 days.

11.3.3 Verification of Coverage

Contractor shall furnish the Owner with Certificates of Insurance reflecting proof of required coverage. The Certificates for each insurance policy are to be signed by a person authorized by that insurer to bind coverage on its behalf. The Certificates are to be received and approved by the Owner before Work commences and upon any contract renewal or insurance policy renewal thereafter. The Certificate Holder must be listed as follows:

State of Louisiana  
 Name of Owner  
 Owner Address  
 City, State, Zip  
 Attn: Project # \_\_\_\_\_

The Owner reserves the right to request complete certified copies of all required insurance policies at any time.

Upon failure of the Contractor to furnish, deliver and maintain required insurance, this contract, at the election of the Agency, may be suspended, discontinued, or terminated. Failure of the Contractor to purchase and/or maintain any required insurance shall not relieve the Contractor from any liability or indemnification under the contract.

If the Contractor does not meet the insurance requirements at policy renewal, at the option of the Owner, payment to the Contractor may be withheld until the requirements have been met, OR the Owner may pay the renewal premium and withhold such payment from any monies due the Contractor, OR the contract may be suspended or terminated for cause.

#### 11.3.4 Subcontractors

Contractor shall include all subcontractors as insureds under its policies OR shall be responsible for verifying and maintaining the certificates provided by each subcontractor. Subcontractors shall be subject to all of the requirements stated herein. The Owner reserves the right to request copies of subcontractor's certificates at any time.

If Contractor does not verify subcontractors' insurance as described above, Owner has the right to withhold payments to the Contractor until the requirements have been met.

#### 11.3.5 Worker's Compensation Indemnity

In the event Contractor is not required to provide or elects not to provide Worker's compensation coverage, the parties hereby agree the Contractor, its Owners, agents and employees shall have no cause of action against, and shall not assert a claim against, the State of Louisiana, its departments, agencies, agents and employees as an employer, whether pursuant to the Louisiana Worker's Compensation Act or otherwise, under any circumstance. The parties also hereby agree that the State of Louisiana, its departments, agencies, agents and employees shall in no circumstance be, or considered as, the employer or statutory employer of Contractor, its Owners, agents and employees. The parties further agree that Contractor is a wholly independent Contractor and is exclusively responsible for its employees, Owners, and agents. Contractor hereby agrees to protect, defend, indemnify and hold the State of Louisiana, its departments, agencies, agents and employees harmless from any such assertion or claim that may arise from the performance of this contract.

#### 11.3.6 Indemnification/Hold Harmless Agreement

Contractor agrees to protect, defend, indemnify, save, and hold harmless, the State of Louisiana, all State Departments, Agencies, Boards and Commissions, its officers, agents, servants, employees and volunteers, from and against any and all claims, damages, expenses and liability arising out of injury or death to any person or the damage, loss or destruction of any property which may occur, or in any way grow out of, any act or omission of Contractor, its agents, servants and employees, or any and all costs, expenses and/or attorney fees incurred by Contractor as a result of any claims, demands, suits or causes of action, except those claims, demands, suits or causes of action arising out of the negligence of the State of Louisiana, all State Departments, Agencies, Boards, Commissions, its officers, agents, servants, employees and volunteers.



Contractor agrees to investigate, handle, respond to, provide defense for and defend any such claims, demands, suits or causes of action at its sole expense and agrees to bear all other costs and expenses related thereto, even if the claims, demands, suits, or causes of action are groundless, false or fraudulent. The State of Louisiana may, but is not required to, consult with the Contractor in the defense of claims, but this shall not affect the Contractor's responsibility for the handling and expenses of all claims.

## **11.4 PERFORMANCE AND PAYMENT BOND**

- 11.4.1 The Owner shall have the right to require the Contractor to furnish bonds covering faithful performance of the Contract and payment of obligations arising thereunder as stipulated in bidding requirements or specifically required in the Contract Documents on the date of execution of the Contract.
- 11.4.2 Upon the request of any person or entity appearing to be a potential beneficiary of bonds covering payment of obligations arising under the Contract, the Contractor shall promptly furnish a copy of the bonds or shall authorize a copy to be furnished.
- 11.4.3 Recordation of Contract and Bond [La R.S. 38:2241 thru 38:2241.1]

The Owner shall record within thirty (30) days the Contract Between Owner and Contractor and Performance and Payment Bond with the Clerk of Court in the Parish in which the Work is to be performed.

## **ARTICLE 12**

### **UNCOVERING AND CORRECTION OF WORK**

## **12.2 CORRECTION OF WORK**

### **12.2.1 Before Substantial Completion**

At the end of the paragraph, add the following sentences:

“If the Contractor fails to correct Work identified as defective within a thirty (30) day period, through no fault of the Designer, the Owner may hold the Contractor in default. If the Owner finds the Contractor in default, the Surety shall be notified. If within thirty (30) days after notification, the Surety has not corrected the nonconforming Work, through no fault of the Architect or Owner, the Owner may contract to have nonconforming Work corrected and hold the Surety and Contractor responsible for the cost, including architectural fees and other indirect costs. If the Surety fails to correct the Work within the stipulated time period and fails to meet its obligation to pay the costs, the Owner may elect not to accept bonds submitted in the future by the Surety. Finding the Contractor in default shall constitute a reason for disqualification of the Contractor from bidding on future state contracts.

### **12.2.2 After Substantial Completion**

12.2.2.1 At the end of the paragraph delete the last sentence and add the following sentences:

“If the Contractor fails to correct nonconforming Work, or Work covered by warranties, within a thirty (30) day period, through no fault of the Architect or Owner, the Owner may hold the Contractor in default. If the Owner finds the Contractor is in default, the Surety shall be notified. If within thirty (30) days after notification, the Surety has not corrected the non-conforming or warranty Work, through no fault of the Architect or Owner, the Owner may contract to have the nonconforming or warranty Work corrected and hold the Surety responsible for the cost including architects fees and other indirect costs. Corrections by the Owner shall be in accordance with Section 2.4. If the Surety fails to correct the nonconforming or warranty Work within the stipulated time period and fails to meet its obligation to pay the costs, the Owner may not accept bonds submitted, in the future, by the Surety.”

## **ARTICLE 13**

### **MISCELLANEOUS PROVISIONS**

#### **13.1 GOVERNING LAW**

Delete all after the word “located”.

#### **13.2 SUCCESSORS AND ASSIGNS**

13.2.1 In the second sentence, delete “Except as ... 13.2.2”

Delete Section 13.2.2.

#### **13.3 RIGHTS AND REMEDIES**

Add the following Section 13.3.3:

13.3.3 The Nineteenth Judicial Court in and for the Parish of East Baton Rouge, State of Louisiana shall have sole jurisdiction and venue in any action brought under this contract.

#### **13.4 TESTS AND INSPECTIONS**

In Section 13.4.1, delete the second sentence and substitute the following:

The Contractor shall make arrangements for such tests, inspections and approvals with the Testing Laboratory provided by the Owner, and the Owner shall bear all related costs of tests, inspections and approvals.

Delete the last two sentences of Section 13.4.1.

#### **13.5 INTEREST**

Delete Section 13.5.

## ARTICLE 14

### TERMINATION OR SUSPENSION OF THE CONTRACT

#### 14.1 TERMINATION BY THE CONTRACTOR

Delete Section 14.1.1.4.

In Section 14.1.3, after the word “profit,” delete the words “on Work not executed” and substitute the following: “for Work completed prior to stoppage”.

#### 14.2 TERMINATION BY THE OWNER FOR CAUSE

Add the following Section:

14.2.1.5 failure to complete the punch list within the lien period as provided in 9.8.7.

14.2.3 Add the following sentence:

“Termination by the Owner shall not suspend assessment of liquidated damages against the Surety.”

Add the following Section:

14.2.5 If an agreed sum of liquidated damages has been established, termination by the Owner under this Article shall not relieve the Contractor and/or Surety of his obligations under the liquidated damages provisions and the Contractor and/or Surety shall be liable to the Owner for per diem liquidated damages.

#### 14.4 TERMINATION BY THE OWNER FOR CONVENIENCE

In Section 14.4.3, delete all after “incurred by reason of the termination,” and add “along with reasonable profit on the Work not executed.”

## ARTICLE 15

### CLAIMS AND DISPUTES

#### 15.1 CLAIMS

Delete Section 15.1.2, **Time Limit on Claims**, (See La R.S. 38:2189, and 38:2189.1).

15.1.3.1 Add the following to the end of the paragraph:

“A Reservation of Rights and similar stipulations shall not be recognized under this contract as having any effect. A party must make a claim as defined herein within the time limits provided.”

15.1.4.2 In the first sentence of the Section, delete “Initial Decision Maker’s” and replace with “Architect’s”. In the second sentence of the Section, delete “the decision of the Initial Decision Maker” and replace with: “his/her decision”.

Delete Section 15.1.6.2 and substitute the following:

Because this project involves interior work, no time extensions for inclement weather is granted.

## **15.2 INITIAL DECISION**

15.2.1 In the second sentence, delete the word “will” and replace with: “shall always”.

In the second sentence, delete the phrase: “, unless otherwise indicated in the Agreement.”

In the third sentence, delete the word “mediation” and replace with: “litigation”.

At the end of the third sentence, add: “arising prior to the date final payment is due”.

Delete the fourth sentence.

15.2.5 In the middle of the first sentence, delete all after the phrase: “rejecting the Claim”.

In the second sentence, delete the phrase: “and the Architect, if the Architect is not serving as the Initial Decision Maker,”.

In the third sentence, delete all after: “binding on the parties” and add the following: “except that the Owner may reject the decision or suggest a compromise or both”.

Delete Section 15.2.6.

Delete Section 15.2.6.1.

## **15.3 MEDIATION**

Delete Section 15.3.

## **15.4 ARBITRATION**

Delete Section 15.4.

- End of Supplementary Conditions -

# Construction Contract Change Order Proposal SUMMARY

COR No. (or RFP, ASI, etc.) \_\_\_\_\_

Date: \_\_\_\_\_

Project No. \_\_\_\_\_

Project Name: \_\_\_\_\_  
\_\_\_\_\_

Contractor Name: \_\_\_\_\_

Description of Work: \_\_\_\_\_  
\_\_\_\_\_  
\_\_\_\_\_

**Work by General Contractor - General Contractor Direct Costs**  
(See attached breakdowns)

Breakdown No. \_\_\_\_\_  
Breakdown No. \_\_\_\_\_  
Breakdown No. \_\_\_\_\_  
Breakdown No. \_\_\_\_\_

Total General Contractor Direct Cost \$ - \_\_\_\_\_ %    
(General Contract Direct Cost plus OH&P) (Max 15%)  
OH&P

**Subcontractor Cost Breakdowns**  
(See attached.)

		A	B	C
Subcontractor Name	Breakdown No.	Total Direct Cost	OH&P (Max 15%)	Total A+(A X B)
_____	_____	_____	%	_____
_____	_____	_____	%	_____
_____	_____	_____	%	_____
_____	_____	_____	%	_____

Subcontractor Direct Costs + Subcontractor OH&P \_\_\_\_\_  
(Sum column C)

General Contractor OH&P on Subcontractor Direct Cost at \_\_\_\_\_ %  
(Sum column A times General Contractor OH&P rate. ) (Max: 10%)

Total Subcontractor Costs with General Contractor OH&P  

Change Order Subtotal    
(Sum of Total General Contractor Costs and Total Subcontractor Costs)

Performance and Payment Bond at \_\_\_\_\_ %  
(Change Order Subtotal times Performance and Payment Bond rate)

Contract amount will be  increased  decreased  unchanged by    
(Sum of Change Order Subtotal and Performance and Payment Bond)

Contract time will be  increased  decreased  unchanged by    
(Attach supporting data such as meteorological reports) days

# Construction Contract Change Order Proposal

## BREAKDOWN

(Provide one breakdown for each work item.)

Breakdown No. \_\_\_\_\_

COR No. (or RFP, ASI, etc.) \_\_\_\_\_

Date: \_\_\_\_\_

Project No. \_\_\_\_\_

Project Name: \_\_\_\_\_

Contractor/Subcontractor Name: \_\_\_\_\_

### Direct Cost of Work :

#### A. Labor

Check here if explained on the Comment Sheet

		Hourly Wage Rate	Hours	Total Cost
1	_____	_____	_____	_____
2	_____	_____	_____	_____
3	_____	_____	_____	_____
4	_____	_____	_____	_____
5	_____	_____	_____	_____
6	_____	_____	_____	_____

Add Labor Burden @ \_\_\_\_\_ %

**LABOR TOTAL**

#### B. Material

		Unit Price	Unit	Units	Total Cost
1	_____	_____	_____	_____	_____
2	_____	_____	_____	_____	_____
3	_____	_____	_____	_____	_____
4	_____	_____	_____	_____	_____
5	_____	_____	_____	_____	_____
6	_____	_____	_____	_____	_____

(Copies of invoices may be required.)

Add Tax @ \_\_\_\_\_ %

**MATERIAL TOTAL**

#### C. Equipment

		Unit Rate	Unit	Units	Total Cost
1	_____	_____	_____	_____	_____
2	_____	_____	_____	_____	_____
3	_____	_____	_____	_____	_____
4	_____	_____	_____	_____	_____
5	_____	_____	_____	_____	_____
6	_____	_____	_____	_____	_____

(Copies of invoices may be required.)

Add Tax @ \_\_\_\_\_ %

**EQUIPMENT TOTAL**

**TOTAL DIRECT COST FOR THIS BREAKDOWN:**

(Sum A, B & C)



# Specifications



## SECTION 01 01 00 - BASIC REQUIREMENTS

### PART 1 - GENERAL

#### 1.1 GENERAL SUMMARY OF THE WORK

- A. The Work described in these Contract Documents is for toilet room renovations in an occupied building, in an existing occupied school campus.
- B. Construction Documents: Contractor to whom the project is awarded, shall download construction documents, drawings and project manual including addenda, from the Owner's website; and the Contractor shall be responsible for making copies that are needed by the Contractor for use during construction. In addition, Contractor shall provide complete sets of documents as follows:
  - 1. One set at project site for reference during project meetings.
  - 2. One set for record drawings.
- C. The Work will be constructed under a single prime contract.

#### 1.2 CONTRACTOR USE OF FACILITY

- A. Building Occupancy: The existing facility is an occupied facility. Conduct construction operations to minimize disturbance and disruptions.
- B. Area of Work: Turned over to Contractor for the Work.
  - 1. Provide signage indicating temporary unavailability of these restroom facilities. Direct building occupants to temporarily use restrooms in the second floor.
  - 2. Provide temporary barricades or secure doors to prevent unauthorized persons from entering work areas.
- C. Staging Area: An area near the building will be assigned to the Contractor for his use. Restore and clean staging area to original condition including replenishing lawns and landscaping.
- D. Material Delivery: Will be assigned at pre-construction meeting.
- E. Contractor is responsible for security and safety of his materials, equipment and temporary facilities as well as protection of Owner's existing facilities.
- F. Safety Plan: Contractor's responsibility. Contractor to maintain first aid kit on jobsite.
- G. Fire Suppression: Contractor may use building fire extinguishers. If used, Contractor to re-charge them.
- H. Owner's Facility Rules and Requirements.
  - 1. Contractor's Access to and in Building: Use assigned entry into the building to avoid conflict with Owner's personnel and visitors.
  - 2. Do not enter other parts of buildings not affected by the work.
  - 3. Obtain permission to work weekends on campus.
- I. Parking: Contractor to purchase parking permits for parking on campus.

### 1.3 OWNER'S USE OF FACILITY

- A. Owner's Occupancy: Portions of work, once occupied and used by the Owner is to remain in Owner's use throughout the remainder of the construction period.
- B. Egress for Owner Personnel: During construction, maintain existing means of egress at all times. Do not obstruct these existing means of egress.
- C. Protection: Provide temporary dust control measures to protect completed Owner occupied spaces against construction dust, etc., throughout the remainder of the construction period. After the new construction is completed, remove temporary dust control measures.
- D. Utilities Services: Do not interrupt utility services to the adjacent occupied spaces. Coordinate with the Owner if temporary modifications to the lighting, power, or air-conditioning systems will cause such interruption, provide advance written notice a minimum of 72 hours before the outage.

### 1.4 COORDINATION

- A. Coordinate scheduling, submittals, and Work to assure efficient and orderly sequence of installation of interdependent construction elements.
- B. Verify utility requirement characteristics of operating equipment are compatible with building utilities.

### 1.5 PROTECTION OF INSTALLED WORK

- A. Protect installed Work and existing facilities to remain. Repair, replace and restore damage(s) at no cost to Owner.
- B. Before beginning of construction operations, inspect and photograph driveways and access to construction area jobsite. Portions of driveway, landscaping and existing improvements damaged by construction operations shall be repaired and replaced at Contractor's expense.

### 1.6 PROJECT MEETINGS

- A. Pre-construction Conference: The Owner and Architect will schedule a pre-construction conference after notice of award. The Contractor shall be responsible to see that his subcontractors are in attendance. At this meeting, submit to the Architect and Owner the following:
  - 1. List of subcontractors and material suppliers.
  - 2. Proposed Construction Progress Schedule.
- B. Progress Meetings: Schedule and administer meetings throughout progress of the Work at monthly intervals coordinated with preparation of payment request. Require each entity to be properly represented to review adherence to schedule with respect to material delivery, work sequencing, hours of work and relevant matters in relationship to the progress schedule. Record minutes of the meeting, update the construction progress schedule, and submit with payment request.

## 1.7 SUBSTITUTIONS

- A. Architect's Approval Required: Consideration will be given to submittals for substitutions only when such proposals are accompanied by complete technical data and information showing compliance to specified requirements. No substitutions are allowed without the Architect's approval.
- B. "Approved Equal" and "or Equal": Substitution under this category must be submitted in accordance with requirements indicated in Instruction to Bidders.
- C. Contractor shall verify and coordinate compatibility with related construction, accommodation to space/area provided, and clearances for service access for substitution items.

## 1.8 SUBMITTAL PROCEDURES AND SHOP DRAWINGS

- A. Procedures:
  - 1. Identification: Identify each submittal with Project (name as appears on the Contract), Contractor, Subcontractor or supplier; and pertinent Contract Document references.
  - 2. Contractor's Approval: Apply date and Contractor's stamp with authorized original hand signature on each copy, certifying that review, verification of Products required, field dimensions, adjacent construction Work and coordination of information is in accordance with the requirements of the Work and Contract Documents. Identify variations from Contract Documents and Product or system limitations which may be detrimental to successful performance of the completed Work. Prior to submittal of shop drawings to the Architect, Contractor shall check shop drawings and affix thereto a stamp indicating his checking and approval with signature (initials are not acceptable) by an authorized officer of the firm on each copy. Shop drawings marked "approved as noted" by the Contractor are assumed to be approved for fabrication or placing orders. Contractor's stamp shall contain the message "Checked and Approved, name of the firm, and date.
  - 3. Revise and resubmit submittals as required; identify changes made since previous submittal.
  - 4. Number of Copies: Number of copies Contractor requires for the Contractor's own use, plus 2 copies which will be retained by Architect.
  - 5. Scheduling Submittals: Allow Architect 10 working days for Architect's review. Delays caused by tardiness of poor scheduling of submittals is the Contractor's responsibility.
  - 6. Grouping: Submit associated items in groups to avoid rejection of a single item that may impact upon the rest of the group.
  - 7. It is the Contractor's responsibility for proper distribution to subcontractors of shop drawings and advise them of the number of prints required for complete job use.
- B. Shop Drawings:
  - 1. Draw to scale sufficiently large showing pertinent features and method of connection. Reproductions or duplications of Architect's drawings is not acceptable.
  - 2. Submit in the form of blue or black line on white background.

- C. Product Data: Mark each copy to identify applicable products, models, options, and other data. Supplement manufacturers' standard data to provide information unique to this project.
- D. Samples: Submit samples to illustrate the characteristics of the Product to be used.
- E. Manufacturer's Instructions: When specified in individual specification Sections, submit manufacturers' printed instructions for delivery, storage, assembly and installation.
- F. Certificates: When specified in individual specification Sections, submit manufacturers' certificate attesting to requirements specified. Indicate material or Product conforms to or exceeds specified requirements. Submit supporting reference data, affidavits, and certifications as appropriate.

#### 1.9 CONSTRUCTION PROGRESS SCHEDULE

- A. Submit proposed Construction Progress Schedule at the Pre-construction Meeting.
- B. Construction Progress Schedule Form: Bar-type progress schedule showing period for each major category or unit of work to be performed, properly sequenced and interfaced. Show completion of work sufficiently in advance of date established for completion of work. With this submittal, include a tabulation (by date) of shop drawing and product data submittals required reflecting allowance periods for review, approval, re-submittal for approval should rejection occur, order and delivery of materials interfacing with the work. Contractor may indicate these dates on the bar chart schedule instead of a separate tabulation.
- C. Present updated schedule at each progress meeting and submit revised schedule with each Application for Payment, identifying changes since previous version. Indicate estimated percentage of completion for each item of Work at each submission.

#### 1.10 TEMPORARY FACILITIES

- A. Electricity and Lighting: Temporarily connect to existing power service nearby. Power consumption shall not disrupt Owner's use of service elsewhere. Owner to pay for power consumed at these connections.
  - 1. Electricity: Provide power outlets for construction operations, branch wiring, distribution boxes, flexible power cords and fixtures as required.
  - 2. Lighting: Provide temporary lighting with local switching that provides adequate illumination for construction operations and traffic conditions.
- B. Communications - Jobsite: Contractor and superintendent shall be accessible by communications contact during entire period of construction operations.
  - 1. Do not use Owner's telephone(s) at the facility.
  - 2. Provide, maintain and pay for cellular phone communications during construction at the project site.
- C. Water: Connect to existing water source for construction operations. Provide necessary hose extensions. Ensure no leaks occur at connections. Remove connections at the end of work.

- D. Drinking Water - Use existing drinking fountains.
- E. Toilet Facilities: Contractor may use toilet facilities in the building. Clean and remove stains and smudges caused by Contractor and his workers.
- F. Field Office - Not required.
- G. Dumpster:
  - 1. Do not use Owner's dumpsters and trash receptacles.
  - 2. Provide and locate dumpster on site at Owner's approved location. Regularly remove contents and clean area so that Owner's property is maintained in a clean and neat conditions at all times.
- H. Haul off and remove construction debris at the end of each day, more often if required to avoid trash build up.
- I. Removal: Remove temporary facilities and materials at the end of the project. Repair damage caused by installation or use of temporary work. Restore and clean existing facilities and areas used during construction to original condition.

#### 1.11 PRODUCT DELIVERY, STORAGE, AND HANDLING

- A. General Product Requirements: Provide products that comply with the Contract Documents, that are undamaged, and unless otherwise indicated, that are new at time of installation.
  - 1. Provide complete with accessories, trim, finish, fasteners, and other items needed for a complete installation and indicated use and effect.
  - 2. Standard Products: If available, and unless custom products or nonstandard options are specified, provide standard products of types that have been produced and used successfully in similar situations on other projects.
  - 3. Where products are accompanied by the term "as selected," Architect will make selection.
  - 4. Where products are accompanied by the term "match sample," sample to be matched is Architect's.
- B. Deliver, store, and handle products using means and methods that will prevent damage, deterioration, and loss, including theft. Comply with manufacturer's written instructions.
  - 1. Schedule delivery to minimize long-term storage at Project site and to prevent overcrowding of construction spaces.
  - 2. Coordinate delivery with installation time to ensure minimum holding time for items that are flammable, hazardous, easily damaged, or sensitive to deterioration, theft, and other losses.
  - 3. Deliver products to Project site in an undamaged condition in manufacturer's original sealed container or other packaging system, complete with labels and instructions for handling, storing, unpacking, protecting, and installing.
  - 4. Inspect products on delivery to ensure compliance with the Contract Documents and to ensure that products are undamaged and properly protected.
  - 5. Store products to allow for inspection and measurement of quantity or counting of units.
  - 6. Store materials in a manner that will not endanger Project structure.

7. Store products that are subject to damage by the elements, under cover in a weathertight enclosure above ground, with ventilation adequate to prevent condensation.
8. Comply with product manufacturer's written instructions for temperature, humidity, ventilation, and weather-protection requirements for storage.
9. Protect stored products from damage.

C. Storage: Provide a secure location and enclosure at Project site for storage of materials and equipment.

#### 1.12 EXECUTION REQUIREMENTS

A. General: Locate the Work and components of the Work accurately, in correct alignment and elevation, as indicated.

1. Make vertical work plumb and make horizontal work level.
2. Where space is limited, install components to maximize space available for maintenance and ease of removal for replacement.
3. Conceal pipes, ducts, and wiring in finished areas, unless otherwise indicated.

B. Comply with manufacturer's written instructions and recommendations for installing products in applications indicated.

C. Install products at the time and under conditions that will ensure the best possible results. Maintain conditions required for product performance until Substantial Completion.

D. Conduct construction operations so no part of the Work is subjected to damage or loading in excess of that expected during normal conditions of occupancy.

E. Tools and Equipment: Do not use tools or equipment that produce harmful noise levels.

F. Anchors and Fasteners: Provide as required to anchor each component securely in place, accurately located and aligned with other portions of the Work.

1. Mounting Heights: Where mounting heights are not indicated, mount components at heights directed by Architect.
2. Allow for building movement, including thermal expansion and contraction.

G. Joints: Make joints of uniform width. Where joint locations in exposed work are not indicated, arrange joints for the best visual effect. Fit exposed connections together to form hairline joints.

H. Hazardous Materials: Use products, cleaners, and installation materials that do not contain hazardous materials.

#### 1.13 PROGRESS AND FINAL CLEANING

A. Progress Cleaning

1. Keep areas free of waste materials, debris, and rubbish.
2. Maintain site in a clean and orderly condition at all times.
3. Clean site daily, and more often when waste materials and debris interfere with other operations.

- B. Final Cleaning
  - 1. Remove waste and surplus materials, rubbish, and construction facilities from the site.
  - 2. Clean surfaces and areas, new and existing, affected by Work and restore to condition before if damaged.
  - 3. Restore site areas affected by work.

#### 1.14 PROJECT RECORD DOCUMENTS

- A. Maintain on site, one set of Contract Documents to be utilized for record documents. Identify on this set by indicating "Record Documents - Job Set." Record actual revisions to the Work. Record information concurrent with construction progress.
- B. Record Documents: Legibly mark each item to record actual construction with ink or color pencil. Submit to Architect before Final Application for Payment.

#### 1.15 SUBSTANTIAL COMPLETION

- A. Preliminary Procedures: Before requesting inspection for determining date of Substantial Completion, complete the following. List items below that are incomplete in request.
  - 1. Prepare a list of items to be completed and corrected (punch list), the value of items on the list, and reasons why the Work is not complete.
  - 2. Obtain and submit releases permitting Owner unrestricted use of the Work and access to services and utilities. Include occupancy permits, operating certificates, and similar releases.
  - 3. Deliver tools, spare parts, extra materials, and similar items to location designated by Owner. Label with manufacturer's name and model number where applicable.
  - 4. Make final changeover of permanent locks and deliver keys to Owner. Advise Owner's personnel of changeover in security provisions.
  - 5. Complete startup testing of systems.
  - 6. Submit test/adjust/balance records.
  - 7. Terminate and remove temporary facilities from Project site, along with mockups, construction tools, and similar elements.
  - 8. Advise Owner of changeover in heat and other utilities.
  - 9. Submit changeover information related to Owner's occupancy, use, operation, and maintenance.
  - 10. Complete final cleaning requirements, including touchup painting.
  - 11. Touch up and otherwise repair and restore marred exposed finishes to eliminate visual defects.
- B. Inspection: Submit a written request for inspection for Substantial Completion. On receipt of request, Architect will either proceed with inspection or notify Contractor of unfulfilled requirements. Architect will prepare the Certificate of Substantial Completion after inspection or will notify Contractor of items, either on Contractor's list or additional items identified by Architect, that must be completed or corrected before certificate will be issued.
  - 1. Re-inspection: Request re-inspection when the Work identified in previous inspections as incomplete is completed or corrected.
  - 2. Results of completed inspection will form the basis of requirements for Final Completion.

#### 1.16 FINAL COMPLETION

- A. Preliminary Procedures: Before requesting final inspection for determining date of Final Completion, complete the following:
  - 1. Submit items listed in Section 012900 Payment Procedures, Article 1.4 - I Final Payment Application.
  - 2. Complete or otherwise resolve for acceptance, the list of items to be completed or corrected (punch list).
- B. Inspection: Submit a written request for final inspection for acceptance. On receipt of request, Architect will either proceed with inspection or notify Contractor of unfulfilled requirements. Architect will either certify a final Certificate for Payment after inspection, or will notify Contractor of construction that must be completed or corrected before certificate will be issued.
  - 1. Re-inspection: Request re-inspection when the Work identified in previous inspections as incomplete is completed or corrected.

#### 1.17 OPERATING AND MAINTENANCE MANUALS

- A. General: Prepare and submit manuals in durable hard plastic binders approximately 8-1/2 by 11 inches in size and with at least the following:
  - 1. Identification on, or readable through, the front cover ~~stating general nature~~ of the manual and the name of the project as shown on the front cover of this Project Manual.
  - 2. Neatly typewritten index near the front of the manual, furnishing immediate information as to location in the manual of emergency data regarding the installation.
  - 3. Complete instructions regarding operation and maintenance of equipment involved.
  - 4. Complete nomenclature of replaceable parts, their part numbers, current cost, and name and address of nearest vendor of parts.
  - 5. Copy of guarantees and warranties issued.
  - 6. Copy of the approved shop drawings with ~~data concerning~~ changes made during construction.
- B. Extraneous Data: Where contents of manuals include manufacturer's catalog pages, clearly indicate the precise items included in this installation and delete, or otherwise clearly indicate, manufacturers' data with which this installation is not concerned.
- C. Manuals:
  - 1. Binders with Hard/Paper Copies
    - a. 2 volumes with complete information, including warranties.
  - 2. Digital Copy: 1 copy with entire set of information on disk, thumb drive or by Dropbox. Well organized into pdf files, searchable.

#### 1.18 CONTRACT CLOSEOUT PROCEDURES

- A. Submit written statement when Work is complete in accordance with Contract Documents and ready for Architect inspection.
- B. The following items must be submitted prior to, or together with, final Application for Payment:
  - 1. Record Drawings



2. Lien Certificate
  3. Consent of Surety
- C. Submit final Application for Payment identifying total adjusted Contract Sum/Price, previous payments, and amount remaining due.

PART 2 - PRODUCTS (not used)

PART 3 - EXECUTION (not used)

END OF SECTION 01 01 00

## SECTION 01 29 00 - PAYMENT PROCEDURES

### PART 1 - GENERAL

#### 1.1 SUMMARY

- A. This Section specifies administrative and procedural requirements to prepare and process Applications for Payment.

#### 1.2 DEFINITIONS

- A. Schedule of Values: A statement furnished by Contractor allocating portions of the Contract Sum to various portions of the Work and used as the basis for reviewing Contractor's Applications for Payment.

#### 1.3 SCHEDULE OF VALUES

- A. Coordination: Coordinate preparation of the Schedule of Values with preparation of Contractor's Construction Schedule.
  - 1. Correlate line items in the Schedule of Values with other required administrative forms and schedules, including the following:
    - a. Application for Payment forms with Continuation Sheets.
    - b. Submittals Schedule.
- B. Format and Content: Use the form provided.

#### 1.4 APPLICATIONS FOR PAYMENT

- A. Each Application for Payment shall be consistent with previous applications and payments as certified by Architect and paid for by Owner.
  - 1. Initial Application for Payment, Application for Payment at time of Substantial Completion, and final Application for Payment involve additional requirements.
  - 2. Stored Materials: No payment will be made for materials and products stored anywhere off site, including a bonded warehouse.
- B. Payment Application Forms: Use AIA Document G702 and AIA Document G703 Continuation Sheets as form for Applications for Payment.
  - 1. Submit payment applications on original AIA G702 and G703 forms; or AIA licensed software of these forms. Non-AIA payment application forms or software that are similar are not acceptable.
- C. Application Preparation: Complete every entry on form. Notarize and execute by a person authorized to sign legal documents on behalf of Contractor. Architect will return incomplete applications without action.
  - 1. Entries shall match data on the Schedule of Values and Contractor's Construction Schedule. Use updated schedules if revisions were made.
  - 2. Include amounts of Change Orders and Construction Change Directives issued before last day of construction period covered by application.

- D. Transmittal: Submit one original and one copy signed and notarized for each Application for Payment to Architect.
- E. Initial Application for Payment: Administrative actions and submittals that must precede or coincide with submittal of first Application for Payment include the following:
  - 1. List of subcontractors.
  - 2. Schedule of Values.
  - 3. Contractor's Construction Schedule (preliminary if not final).
  - 4. Certificates of insurance and insurance policies.
- F. Application for Payment at Substantial Completion: After issuing the Certificate of Substantial Completion, submit an Application for Payment showing 100 percent completion for portion of the Work claimed as substantially complete.
  - 1. Include documentation supporting claim that the Work is substantially complete and a statement showing an accounting of changes to the Contract Sum.
  - 2. This application shall reflect Certificates of Partial Substantial Completion issued previously for Owner occupancy of designated portions of the Work.
- G. Prior to Final Application for Payment: The following items must be submitted:
  - 1. Record Drawings
- H. Final Payment Application: Submit final Application for Payment with releases and supporting documentation not previously submitted and accepted, including, but not limited, to the following:
  - 1. Lien-free certificate.

PART 2 - PRODUCTS (Not Used)

PART 3 - EXECUTION (Not Used)

END OF SECTION 01 29 00

attachment  
Schedule of Values

**SCHEDULE OF VALUES**

*The Contractor is to use the following format.*

*The total Contract Cost is to be itemized in each Subsection listed (as applicable)*

	Item Cost	Cost
<b>DIVISION 1 – GENERAL REQUIREMENTS</b>		
01 00 00 General Requirements		
Bond & Insurance	_____	
Mobilization & Set up	_____	
General conditions, project superintendent	_____	
Temporary Facilities, Equipment rental	_____	
Demobilization & cleanup	_____	
<b>DIVISION 1 – GENERAL REQUIREMENTS</b>	<b>SUB-TOTAL</b>	<b>0</b>
<b>DIVISION 2 - EXISTING CONDITIONS</b>		
02 41 20 Selective Demolition	_____	
<b>DIVISION 2 - EXISTING CONDITIONS</b>	<b>SUB-TOTAL</b>	<b>0</b>
<b>DIVISION 4 - MASONRY</b>		
04 27 00 Masonry Assemblies	_____	
<b>DIVISION 4 - MASONRY</b>	<b>SUB-TOTAL</b>	<b>0</b>
<b>DIVISION 6 - WOOD, PLASTICS &amp; COMPOSITES</b>		
06 42 00 Solid Surface Counters	_____	
06 64 00 FRP Paneling	_____	
<b>DIVISION 6 - WOOD, PLASTICS &amp; COMPOSITES</b>	<b>SUB-TOTAL</b>	<b>0</b>
<b>DIVISION 8 – OPENINGS</b>		
08 11 13 Metal Doors and Frames	_____	
08 14 16 Wood Doors	_____	
08 71 00 Door Hardware	_____	
<b>DIVISION 8 – OPENINGS</b>	<b>SUB-TOTAL</b>	<b>0</b>
<b>DIVISION 9 – FINISHES</b>		
09 21 16 Drywall Assemblies, including metal stud framing	_____	
09 31 00 Ceramic Tile	_____	
09 51 00 Acoustical Panel Ceilings	_____	
09 90 00 Painting	_____	
<b>DIVISION 9 – FINISHES</b>	<b>SUB-TOTAL</b>	<b>0</b>
<b>DIVISION 10 - SPECIALTIES</b>		
10 14 00 Signage	_____	
10 21 13 Toilet Compartments	_____	
10 28 00 Toilet Accessories	_____	
<b>DIVISION 10 - SPECIALTIES</b>	<b>SUB-TOTAL</b>	<b>0</b>

**SCHEDULE OF VALUES**

*The Contractor is to use the following format.*

*The total Contract Cost is to be itemized in each Subsection listed (as applicable)*

	Item Cost	Cost
DIVISION 22 - PLUMBING		
Plumbing Fixtures & Piping		
DIVISION 22 - PLUMBING	SUB-TOTAL	0
DIVISION 23 - HVAC		
Grilles		
DIVISION 23 - HVAC	SUB-TOTAL	0
DIVISION 26 - ELECTRICAL		
26 50 00 Lighting		
Alarm Devices		
DIVISION 26 - ELECTRICAL	SUB-TOTAL	0
	GRAND TOTAL	0

## SECTION 01 73 00 - CUTTING AND PATCHING

### PART 1 - GENERAL

#### 1.1 SUMMARY

- A. This Section includes procedural requirements for cutting and patching.
  - 1. Cut and patch existing construction to accommodate new construction. Include also, temporary removal, storage and re-installation of existing components as required to accomplish the work.
- B. Related Sections include the following:
  - 1. Section 02 41 15 - Selective Demolition.

#### 1.2 DEFINITIONS

- A. Cutting: Removal of existing construction necessary to permit installation or performance of other Work.
- B. Patching: Fitting and repair work required to restore surfaces to original conditions after installation of other Work.

#### 1.3 QUALITY ASSURANCE

- A. Structural Elements: Do not cut and patch structural elements in a manner that could change their load-carrying capacity or load-deflection ratio.
- B. Operational Elements: Do not cut and patch operating elements and related components in a manner that results in reducing their capacity to perform as intended or that results in increased maintenance or decreased operational life or safety.
- C. Visual Requirements: Do not cut and patch construction in a manner that results in visual evidence of cutting and patching. Do not cut and patch construction in a manner that would, in Architect's opinion, reduce the building's aesthetic qualities. Remove and replace construction that has been cut and patched in a visually unsatisfactory manner.

### PART 2 - PRODUCTS

#### 2.1 MATERIALS

- A. Materials: Use materials identical to existing materials. For exposed surfaces, use materials that visually match existing adjacent surfaces to the fullest extent possible.
  - 1. If identical materials are unavailable or cannot be used, use materials that, when installed, will match the visual and functional performance of existing materials.

### PART 3 - EXECUTION

#### 3.1 EXAMINATION

- A. Examine surfaces and conditions under which cutting and patching are to be performed.

1. Compatibility: Before patching, verify compatibility with and suitability of substrates, including compatibility with existing finishes or primers.
2. Proceed with installation only after unsafe or unsatisfactory conditions have been corrected.

### 3.2 PREPARATION

- A. Temporary Support: Provide temporary support of Work to be cut.
- B. Protection: Protect existing construction during cutting and patching to prevent damage. Provide protection from adverse weather conditions for portions of Project that might be exposed during cutting and patching operations.
- C. Adjoining Areas: Avoid interference with use of adjoining areas or interruption of free passage to adjoining areas.
- D. Existing Services: Where existing services are required to be removed, relocated, or abandoned, bypass such services before cutting to avoid interruption of services to occupied areas.

### 3.3 PERFORMANCE

- A. General: Employ skilled workers to perform cutting and patching. Proceed with cutting and patching at the earliest feasible time, and complete without delay.
  1. Cut existing construction to provide for installation of other components or performance of other construction, and subsequently patch as required to restore surfaces to their original condition.
- B. Cutting: Cut existing construction by sawing, drilling, breaking, chipping, grinding, and similar operations, including excavation, using methods least likely to damage elements retained or adjoining construction.
  1. In general, use hand or small power tools designed for sawing and grinding, not hammering and chopping. Cut holes and slots as small as possible, neatly to size required, and with minimum disturbance of adjacent surfaces. Temporarily cover openings when not in use.
  2. Existing Finished Surfaces: Cut or drill from the exposed or finished side into concealed surfaces.
  3. Mechanical and Electrical Services: Cut off pipe or conduit in walls or partitions to be removed. Cap, valve, or plug and seal remaining portion of pipe or conduit to prevent entrance of moisture or other foreign matter after cutting.
- C. Patching: Patch construction by filling, repairing, refinishing, closing up, and similar operations following performance of other Work. Patch with durable seams that are as invisible as possible. Provide materials and comply with installation requirements specified in other Sections of these Specifications.
  1. Exposed Finishes: Restore exposed finishes of patched areas and extend finish restoration into retained adjoining construction in a manner that will eliminate evidence of patching and refinishing.

END OF SECTION 01 73 00

## SECTION 02 41 20 - SELECTIVE DEMOLITION

### PART 1 - GENERAL

#### 1.1 SUMMARY

- A. Selective demolition includes removal of existing items indicated and required for installation of new work and protection of existing facilities.

#### 1.2 DEFINITIONS

- A. Remove: Detach items from existing construction and legally dispose of them off-site, unless indicated to be removed and salvaged or removed and reinstalled.
- B. Remove and Reinstall: Detach items from existing construction, prepare them for reuse, and reinstall them where indicated.
- C. Existing to Remain: Existing items of construction that are not to be removed and that are not otherwise indicated to be removed, removed and salvaged, or removed and reinstalled.

#### 1.3 MATERIALS OWNERSHIP

- A. Except for items or materials indicated to be reused, salvaged, reinstalled, or otherwise indicated to remain Owner's property, demolished materials shall become Contractor's property and shall be removed from Project site.

#### 1.4 PROJECT CONDITIONS

- A. Owner will occupy portions of building immediately adjacent to selective demolition areas. Conduct selective demolition so Owner's operations will not be disrupted.
- B. Maintain access to existing walkways, corridors, and other adjacent occupied or used facilities.
- C. Owner assumes no responsibility for condition of areas to be selectively demolished.
- D. Hazardous Materials: It is not expected that hazardous materials will be encountered in the Work.
  - 1. If materials suspected of containing hazardous materials are encountered, do not disturb; immediately notify Architect and Owner. Hazardous materials will be removed by Owner under a separate contract.
- E. Storage or sale of removed items or materials on-site will not be permitted.
- F. Utility Service: Maintain existing utilities indicated to remain in service and protect them against damage during selective demolition operations.
  - 1. Maintain fire-protection facilities in service during selective demolition operations.

### PART 2 - PRODUCTS



## 2.1 REPAIR MATERIALS

- A. Use repair materials identical to existing materials.
  - 1. If identical materials are unavailable or cannot be used for exposed surfaces, use materials that visually match existing adjacent surfaces to the fullest extent possible.
  - 2. Use materials whose installed performance equals or surpasses that of existing materials.
- B. Comply with material and installation requirements specified in individual Specification Sections.

## 2.2 MATERIALS – SALVAGE

- A. Do not reuse materials removed from the existing construction in connection with demolition work, except items which are specifically shown or specified to be reused and/or re-located.
- B. Remove and deliver equipment and material selected to remain the property of the Owner to a location on the grounds designated.

## PART 3 - EXECUTION

### 3.1 UTILITY SERVICES

- A. Existing Utilities: Maintain existing services indicated to remain and protect them against damage during selective demolition operations.
- B. Do not interrupt existing utilities serving occupied or operating facilities unless authorized in writing by Owner and authorities having jurisdiction.
  - 1. Provide at least 48 hours' notice to Owner if shutdown of service is required during changeover.

### 3.2 PREPARATION

- A. Temporary Facilities: Provide temporary barricades and other protection required to prevent injury to people and damage to adjacent buildings and facilities to remain.
  - 1. Provide protection to ensure safe passage of people around selective demolition area and to and from occupied portions of building.
  - 2. Protect walls, ceilings, floors, and other existing finish work that are to remain or that are exposed during selective demolition operations.

### 3.3 POLLUTION CONTROLS

- A. Dust Control: Use water mist, temporary enclosures, and other suitable methods to limit spread of dust and dirt.
  - 1. Do not use water when it may damage existing construction or create hazardous or objectionable conditions, such as ice, flooding, and pollution.
  - 2. Wet mop floors to eliminate trackable dirt and wipe down walls and doors of demolition enclosure. Vacuum carpeted areas.

3. To avoid inadvertent generation of dust in occupied portions of the building, bag to contain and seal debris to transport construction waste and related materials from work areas through occupied portions of the building.
- B. Disposal: Remove and transport debris in a manner that will prevent spillage on adjacent surfaces and areas.
- C. Cleaning: Clean adjacent structures and improvements of dust, dirt, and debris caused by selective demolition operations. Return adjacent areas to condition existing before selective demolition operations began.

### 3.4 SELECTIVE DEMOLITION

- A. General: Demolish and remove existing construction only to the extent required by new construction and as indicated. Use methods required to complete the Work within limitations of governing regulations and as follows:
  1. Proceed with selective demolition systematically, from higher to lower level. Complete selective demolition operations above each floor or tier before disturbing supporting members on the next lower level.
  2. Neatly cut openings and holes plumb, square, and true to dimensions required. Use cutting methods least likely to damage construction to remain or adjoining construction. Use hand tools or small power tools designed for sawing or grinding, not hammering and chopping, to minimize disturbance of adjacent surfaces. Temporarily cover openings to remain.
  3. Cut or drill from the exposed or finished side into concealed surfaces to avoid marring existing finished surfaces.
  4. Return elements of construction and surfaces that are to remain to condition existing before selective demolition operations began.
  5. Remove each item completely including straps, hangers, clips, fasteners, shims, blocking and accessories.
  6. Coordinate and allow Owner to remove and store movable items.
  7. Prepare and repair substrates receive new construction. Plug holes from removed fasteners and anchors with similar substrate material such as wood plugs, non-shrink grout, plaster, etc. Provide blocking and construction compatible with existing materials for securing new construction to tie to existing. Patch and level.
- B. Existing Facilities: Comply with building manager's requirements for using and protecting elevators, stairs, walkways, loading docks, building entries, and other building facilities during selective demolition operations.
- C. Removed and Reinstalled Items: Comply with the following:
  1. Clean and repair items to functional condition adequate for intended reuse. Paint equipment to match new equipment.
  2. Protect items from damage during transport and storage.
  3. Reinstall items in locations indicated. Comply with installation requirements for new materials and equipment. Provide connections, supports, and miscellaneous materials necessary to make item functional for use indicated.
- D. Existing Items to Remain: Protect construction indicated to remain against damage and soiling during selective demolition. When permitted by Architect, items may be removed

to a suitable, protected storage location during selective demolition and cleaned and reinstalled in their original locations after selective demolition operations are complete.

### 3.5 SPECIFIC SELECTIVE DEMOLITION ITEMS

- A. Masonry Walls - Openings: Carefully remove portions of masonry construction to provide openings indicated. Cut neatly to provide edges of masonry rough opening to receive new door frame.
- B. Doors: Carefully remove doors, including hardware, to allow existing frames to remain.
  - 1. Clean, repair and prepare opening to satisfactorily receive new door. Rework and repair door frame, including adding reinforcement, for properly securing the new door and hardware.
  - 2. Avoid damage to existing hollow metal frames to remain. Repair and rehabilitate frames by removing rusted areas, removing signs of damage and “Bondo” repair holes and dents.
- C. Door Assemblies: Carefully remove door assemblies, including hardware. Clean, repair and prepare opening to satisfactorily receive new door frame and door. Rework and provide blocking and backup to wall construction for properly securing the new door and frame assembly.
- D. Joint Sealants: Rake and remove existing sealants from joints where surfaces are being painted and elsewhere as indicated or where necessary for performance of work. Remove existing sealant, including backer-rods and accessories completely. Clean, repair and rework joint surfaces in order to satisfactorily receive new sealants and related joint accessory materials such as backer rods and primers.
- E. Partitions: Remove portion or extent of existing partition as indicated. Rework remaining portion and re-finish partition to remain complying with Division 1 Cut and Patch procedures.
  - 1. Exercise care to keep concealed items such as conduits and piping to allow them to remain in the new wall construction. Re-secure electrical devices such as conduits, pullboxes, junction boxes, and other items to new framing.
- F. Ceramic Floor Tile:
  - 1. Floor Tile: Remove completely including mortar setting bed. Prepare, level, patch and clean existing slab to receive new flooring materials. Rework existing plumbing lines to receive plumbing fixtures as described below.
  - 2. Carefully remove to minimize damage to existing setting bed for receiving new floor tile. Fill in depressions and areas where other construction is removed. Level, clean and prepare to receive new floor tile. Ensure that new layout will provide positive drainage to floor drains by using methods such as grinding, patching and leveling.
  - 3. Wall Tile: Carefully remove wall tile including setting cement to avoid damage to concrete masonry substrate. Rework, level and prepare existing masonry substrates are even and flush for receiving new tile finishes.
- G. Ceiling System: Remove ceiling system, including tiles, grid and light fixtures.
  - 1. Leave existing hangers and suspension assembly for the new ceiling system. Examine and verify that the existing connections and items are in good and secure

- condition for supporting new ceiling. Provide corrective action to existing unsatisfactory items and conditions.
2. Exercise care in salvaging and protecting piping, conduits, ceiling grilles, light fixtures, and other ceiling items.
- H. Plumbing Items: Remove fixtures and equipment including hangers, associated piping, accessories and fasteners for new construction.
1. Where fixtures are replaced, rework piping for reconnection with new fixtures. Include transitions, fittings and accessories required for piping reconnections and fixture replacements.
  2. Where piping is removed from the existing concrete floor, plug and fill holes level in the concrete floor with non-shrink grout. Prepare openings to be filled by cleaning openings, apply bonding agent, provide temporary support below opening or secure galvanized sheet metal plate.
- I. Ceiling Light Fixtures: Carefully remove to avoid damage to existing ceiling to remain. Rework existing device boxes, extend and connect service for new light fixtures.

### 3.6 PATCHING AND REPAIRS

- A. General: Promptly repair damage to adjacent construction caused by selective demolition operations.
- B. Patching: Comply with Division 1 Section "Cutting and Patching."

### 3.7 DISPOSAL OF DEMOLISHED MATERIALS

- A. General: Promptly dispose of demolished materials. Do not allow demolished materials to accumulate on-site.
- B. Burning: Do not burn demolished materials.
- C. Disposal: Transport demolished materials off Owner's property and legally dispose of them.

END OF SECTION 02 41 20

## SECTION 02 82 10 - REMOVAL OF ASBESTOS-CONTAINING MATERIALS

### PART 1.0 - GENERAL

#### 1.1 DESCRIPTION OF WORK:

- A. The work specified within this section includes the removal of asbestos-containing materials described herein. The Contractor shall utilize only trained and qualified workers in the removal, handling, and disposal of these materials. The contractor's work practices and methods shall comply will all applicable Federal, State, and local regulations.
- B. The Contractor shall furnish all labor, materials, equipment, medical records, testing, insurance, patents, and incidentals, which are necessary or required to complete the work safely.
- C. The Scope of Work includes the safe removal and disposal of the asbestos-containing and record keeping in accordance with Federal and State regulations.
- D. The Contractor shall coordinate with the Third-Party Air Monitoring and Inspection Firm (Owner's Representative), for the duration of the Work.
- E. Coordinate with Owner's design team, Environmental Project Designer and Architect, and General Contractor who will establish special procedures for removal and salvage.

#### 1.2 APPLICABLE PUBLICATIONS: The publications listed below form a part of this specification to the extent referenced. The publications are referenced in text by basic designation only. The latest publication shall apply.

- A. Environmental Protection Agency (EPA):  
  
Regulations for Asbestos (Code of Federal Regulations, Title 40, Part 61), National Emission Standard for Hazardous Air Pollutants (NESHAP), Guidance for Controlling Friable Asbestos Containing Materials in Buildings, Asbestos Hazard Emergency Response Act (AHERA) (40 CFR, Part 763).
- B. Occupational Safety and Health Administration (OSHA): Asbestos Regulations (Code of Federal Regulations Title 29, Part 1901, Sections 1915.1001 and 1926.1101), 1910 Section 1200 Hazard Communication, Section 145 Signs and Tags, and Section 2 Access to Employee Exposure and Medical Records.
- C. National Institute for Occupational Safety and Health (NIOSH): Respiratory Protection, A Guide for the Employee.
- D. American National Standards Institute (ANSI): Z86.1-1973, Commodity Specification for Air.

- E. Louisiana Administrative Codes (LAC), Title 33, Part III, Chapters 27 and 51, and Louisiana Department of Environmental Quality (LADEQ) and Louisiana Emissions Standard for Hazardous Air Pollutants (LESHAP).

1.3 DEFINITIONS:

- A. Refer to Section 02 80 10 for terms and definitions used in these Contract Documents.

1.4 SUBMITTALS:

- A. Refer to Section 02 80 10 for Contractor submittal requirements.

1.5 RESPIRATORY AND PERSONNEL PROTECTION AND DECONTAMINATION:

- A. Refer to this Section for Contractor respiratory and personnel protection and decontamination requirements.

1.6 WASTE DISPOSAL:

- A. Refer to Sections 02 82 40 for Contractor waste disposal requirements.

**PART 2.0 – PRODUCTS**

The Contractor shall note that where no manufacturer or model number are given, any product meeting performance or design criteria, or referenced trade association standard may be used and Pre-Bid Approval is not required.

2.1 GENERAL REQUIREMENTS:

- A. The Contractor shall deliver all materials to the site in the original containers bearing the name of the manufacturer and details for proper storage and usage.
- B. All materials or equipment delivered to the site shall be unloaded, temporarily stored, and transferred to the Work Area in a manner which shall not interfere with operations of the building occupants.
- C. The unloading and temporary storage sites, and transfer routes, must be approved in advance by the Designer.
- D. Damaged or deteriorated materials may not be used and must be promptly removed from the premises. Material which becomes contaminated with asbestos-containing material shall be packaged and legally disposed of in an approved landfill.

- E. Techniques, procedures, and equipment required by these specifications may be covered by one or more U.S. and/or foreign patents. It is the sole responsibility of the Contractor to determine what, if any, patents are applicable and to meet the requirements of the patent owner, including fees regarding the use of these patents.

## 2.2 MATERIALS, TOOLS, AND EQUIPMENT:

- A. All materials, tools, and equipment must comply at a minimum with these specifications, and relevant Federal, State, and local codes. For the construction of containment barriers, work platforms, and Decontamination Facilities, all lumber and plywood shall be fire-retardant. Flame-resistant polyethylene film shall conform to requirements set forth in the National Fire Protection Association, shall be fire-retardant, and shall bear manufacturer's stamp of Underwriters Laboratory (UL) Classification.

Any equipment used that prevents the analysis of air samples by Phase Contrast Microscopy will be unacceptable and will not be allowed to be used.

1. HEPA-Filtered Exhausts - Air inside each work area shall be exhausted to the atmosphere (building exterior) through a High Efficiency Particulate Air (HEPA) filter. HEPA-filtered portable exhaust units shall be provided for each work area, of sufficient total capacity to provide at least six (6) complete air changes per hour, an inward velocity through all openings to the work area of at least 200ppm, and a static pressure of at least 0.025 inches water column.

The HEPA filter shall be preceded by replaceable pre-filters, and the unit must be designed such that it cannot be operated unless the HEPA filters are in place. The units must also be designed with lights or alarms, which indicate that the filters are properly installed and functional, and which determine when the filters must be changed.

Flexible hoses (ducts) of sufficient length must be provided to allow the units to discharge outside of the buildings. Exhaust with other types of particulate cleaning systems (such as electrostatic precipitators) shall not be allowed.

2. Plastic Sheeting and Bags - These shall be polyethylene or equivalent. Both transparent and opaque plastic shall be required, as specified within the contract documents. Flame-resistant polyethylene shall be used.
3. Encapsulates - Encapsulating or lock-down agents shall be penetrating sealants. Due to subsequent renovation plans, the Contractor shall lock down all surfaces with a water-based and water-soluble encapsulate pre-approved by the Designer. The water-based, water-soluble encapsulate shall be able to do following:
  - a. Withstand most impact or abrasion and protect the encapsulated surface.

- b. Be one of those demonstrating effective performance under the tests conducted by an independent testing laboratory, pre-approved by the Owner's Representative.
- c. Shall have high flame-retardant characteristics less than 25 when tested in accordance with ASTM E-84 procedures, and a low toxic fume and smoke emission rating.
- d. Shall not be noxious or toxic to application workers, or subsequent users of the building.
- e. Shall have some permeability to water vapor to prevent condensation accumulation and shall resist solution by common cleaning agents.
- f. Shall have acceptable weathering and aging characteristics.

It is the Contractor's responsibility to ensure that encapsulates will be compatible with all replacement materials (if required). The Contractor shall coordinate this requirement with the Designer.

- 4. Wetting Agent or Surfactant – This item shall be 50% polyoxyethylene ether and 50% polyoxyethylene ester, or equivalent, mixed in the proportion of one ounce surfactant per five gallons of water. The material must be odorless, non-flammable, non-toxic, non-irritating, and non-carcinogenic. It shall be applied using a low-pressure sprayer recommended by the surfactant manufacturer.
- 5. Tape and Glue - These items shall be capable of sealing plastic joints, and attaching plastic to finished surfaces without damage when they are removed. The bonding strength and resulting seal integrity must not be affected by mist of water, encapsulating agent, or any other materials to be used in the Work Area.
- 6. Warning Signs and Labels - These items shall comply with 29 CFR 1926.1101 (K), and with all other federal, state, or local codes and regulations.
- 7. Waste Containers and Transportation - These items shall be bags as noted in Subparagraph 2 above, drums or other closed containers, suitable for loading, temporary storage, transit, and unloading of contaminated waste without rupture or otherwise causing spillage or exposure to persons or emissions to the atmosphere. Transportation methods shall comply with the provisions of EPA Title 40, Part 61, Subparts A and B, Part 262, and with any hazardous or special waste regulations for temporary storage, transport, and disposal if such codes are enforced in states or cities where the waste will be generated, stored, transported or disposed of. All containers shall be labeled in accordance



with 29 CFR 1926.58K(2) and 49 CFR, Parts 171 and 172, Hazardous Substances: Final Rule.

8. Respiratory Protection Devices - These items shall be NIOSH-approved and shall comply with all provisions of 29 CFR 1926.1101. Fit testing procedures must comply with 29 CFR 1926.1101, Appendix C. Provide documentation of fit-testing procedure.
9. Electrical Equipment – All electrical items shall be Underwriters Laboratory listed and approved, and shall have ground fault circuit interrupt protection, which has been installed by a qualified electrician.
10. Ladders or Scaffolds - These items shall be approved and be of sufficient dimensions and quantities so that all work surfaces can be easily and safely accessed by the Owner's Representative, workers, and other inspectors. Scaffold joints and ends shall be sealed with tape to prevent incursion of asbestos fibers or particulate. The use of aluminum ladders inside the work area is prohibited.
11. Hand Power Tools - These items shall be equipped with HEPA-filtered local exhaust ventilation if used to drill out, into, or otherwise disturb ACM.
12. Brushes - All brushes shall have nylon bristles. Wire brushes are excluded from use due to their potential to shred asbestos fibers into small fibers. Wire brushes may be used on pipe joint applications upon prior written approval by the Designer.

### 2.3 USE OF EXISTING EQUIPMENT

The Contractor is responsible for the maintenance and repair of all existing equipment, which he, or anything associated with his work, damages, impacts, or otherwise disturbs. All existing equipment must be returned to the Owner in its original state. Any repair of equipment to return it to its original state is the sole responsibility of the Contractor. All costs associated with testing, inspection, maintenance, and repair must be borne by the Contractor.

- A. Electricity: The Contractor is responsible for providing his own electricity to the Work Area. Power is available at the Site. All costs associated with testing, inspection, coordination, provision, and total usage of electricity are the responsibility of the Contractor. Contractor shall clean and protect the existing power panels used to obtain power for this project.
- B. Water: The Contractor is responsible for providing water to the Work Areas. Water is available within the building and all costs associated with testing, inspection, coordination of water are the sole responsibility of the Contractor.

## **PART 3.0 - EXECUTION**

### **3.1 GENERAL:**

- A. The requirements and sequences described herein are parameters for execution of the abatement work and do not necessarily include all abatement requirements. The Contractor shall be responsible for all items that may be necessary to complete the abatement work in accordance with the approved Work Plan, Scope of Work, and all applicable regulations. All deviations from the Work Plan must be pre-approved in writing by the Designer.
- B. All building interior removal work shall be performed using full containment, protection with HEPA-filtered exhaust ventilation, and decontamination facilities.

### **3.2 PREABATEMENT PREPARATIONS:** The Contractor shall prepare the work areas using plans pre-approved by the Owner's Representative and Designer. Following is a general sequence of performance steps and procedures to ensure that proper containment and protection systems are installed prior to any work, which could generate airborne asbestos fibers or particulate.

- A. Post access restriction signs; seal all openings into each work area; clean, decontaminate, protect, and cover all fixed items; and erect or install containment barriers, scaffolding, and decontamination facilities and HEPA-exhaust systems as described herein.
- B. The Contractor shall be responsible for providing his own water and electricity to each the work area. Utility connections are available in the building for the Contractor's use. The Contractor is responsible for coordinating the provision of utilities to the Work Areas. Provision of utilities to the Work Areas and Air Monitoring Firms' use shall be borne by the Contractor.
- C. Provide temporary power and lighting equipped with ground fault interrupter (GFI) devices are required for each work area and affected non-work areas.
- D. Obtain Owner's Representative's approval, in writing, of all completed preparation work.

### **3.3 ISOLATION OF ELECTRICAL SYSTEMS AND INSTALLATION OF TEMPORARY POWER AND LIGHTING:**

- A. The scope of the required electrical isolation and protection work includes isolation and protection of electrical equipment, which is in the area from which asbestos must be removed, and which could possibly become a hazard through contact or water spray short-circuiting. Care must be taken when working near electrical panels. The Contractor shall provide labor to monitor, inspect, and service temporary power circuits, lighting, and equipment as required by local codes and regulations. Contractors must provide "Lock Out" systems on all

electrical panels or equipment, which will be shut off during the removal process. If electrical panels, transformers, or control centers cannot be deactivated/de-energized, the Contractor shall ensure that these electrical panels, transformers, control centers, or fire protection panels are isolated utilizing rigid critical barriers, fire retardant 6-mil polyethylene sheeting, and ventilated as required.

- B. The electrical isolation work includes the installation of temporary lighting and power protected by ground fault interrupter (GFI) devices in accordance with applicable codes.
- C. Temporary light shall be provided by the Contractor in each Work Area where abatement is performed. A qualified electrician shall initially inspect the (removal work areas) for the condition of electrical conduit and junction boxes. All temporary electrical work shall comply with NFPA 70 National Electric Code. The purpose of this inspection is to assist the Contractor in the preparation and performance of his work, and to provide for the safety of work crews.
- D. The Contractor shall be required to furnish, without additional expense, all transportation, labor, and materials necessary to maintain the electrical systems for safe operation, and to maintain service in areas abutting work area in compliance with local codes.
- E. All materials and workmanship shall conform with the latest editions of the following codes, standards, and specifications issued by the following authorities:
  - 1. National Electrical Code (NEC) - most recent edition.
  - 2. National Bureau of Standards, Handbook H30, National Electrical Safety Code.
  - 3. State and Local Codes, and all other authorities having jurisdiction.
  - 4. Underwriter Laboratories (UL).
  - 5. National Board of Fire Underwriters.
  - 6. Occupational Safety and Health Administration (OSHA).
- F. Temporary lighting and power systems shall comply with all Federal, State, and local regulations. Temporary lighting levels shall meet these requirements.
- G. When switching circuits at panels, the Contractor's licensed electrician shall review the existing conditions. The Contractor shall not shutdown any circuits without the advanced notification and approval.
- H. Contractor costs associated with the isolation of electrical systems and installation of temporary power and lighting shall be borne by the Contractor.
- I. Extension cords shall be the 3-wire type; shall be protected from damage; and shall not be fastened with staples, hung from nails, or suspended from wires.

Splices shall have soldered wire connection with insulation equal to the cable. Worn or frayed cords shall not be used.

- J. Safe lighting equipment shall be provided with a preference for floodlights rather than indiscriminate use of unprotected lamps strung on temporary wiring. Exposed bulbs shall be guarded to prevent accidental contact. Temporary wiring shall be properly insulated and substantially supported. Circuits shall be properly designed and fused. All temporary lighting inside the work area shall be weather proofed.
- K. Receptacles for attachment plugs shall be an approved, concealed contact type. Where different voltages, frequencies, or types of current are supplied, receptacles shall be of such design that attachment plugs are not interchangeable.

#### 3.4 INSTALLATION OF SCAFFOLDING AND/OR WORK PLATFORMS:

- A. The Contractor shall install and erect sufficient scaffolding and/or work platforms to access all areas and complete all tasks involved in the abatement activities.
- B. Installation and erection of scaffolding and/or work platforms must be done in strict compliance with all applicable Federal, State, and local laws and regulations.
- C. The Contractor is responsible for removing any loose or hanging materials and installing adequate shoring so as to provide and maintain a safe work environment.
- D. The Contractor must maintain public access to city sidewalks, as required by law, throughout the entire abatement project. The Contractor is responsible for obtaining necessary permits involved in erecting scaffolding and/or fencing on public property. The Contractor will be responsible for repairing all damage caused by scaffolding or fencing during abatement.

#### 3.5 ISOLATION OF WORK AREAS AND INSTALLATION OF DECONTAMINATION FACILITIES:

- A. The Contractor shall isolate the Work Area for the duration of the work by completely closing and sealing all openings and penetrations into the Work Area using a minimum two (2) layers of 6-mil polyethylene sheeting, with joints staggered, and taped securely in place. The work area shall be sealed airtight and watertight to the maximum extent possible and shall be subject to the written approval of the Owner's Representative.
- B. Isolation Partitions and Barriers

1. The Contractor shall install scaffolding and/or work platforms and necessary shoring to provide worker access and install approved safety railings, the plates, etc.
  2. The Contractor shall install critical barrier walls using 2"x 4" stud or metal framing 24" on center, adequately supported and anchored, covered with 5/8" (fire rated) sheet packs, all seams caulked airtight. All temporary enclosures and walls shall have a flame spread of 0-200 and a smoke developed of 0-450.
- C. The Contractor shall install decontamination facilities for all work areas as defined herein, using plans pre-approved by the Owner's Representative.
  - D. The Contractor shall cover critical barriers, scaffold planks, and work platforms with a minimum of two (2) layers of 6-mil polyethylene sheeting with joints staggered and taped securely in place.
  - E. The Contractor shall line both sides of walls, ceilings, and floors of decontamination facilities using a minimum of two (2) layers of 6-mil polyethylene sheeting with joints staggered and taped securely in place.
  - F. The Contractor shall provide GFI-protected temporary power and lighting to work areas and ensure safe installation of temporary power sources and equipment.
  - G. The Contractor shall install HEPA-filtered exhaust systems and automatic air pressure differential recording instruments in work areas as previously specified using plans pre-approved by the Designer.
  - H. The Contractor shall install wastewater collection, filtration, storage, and discharge systems, and install waste holding facilities.
  - I. The Contractor shall post warning signs meeting the requirements of 29 CFR 1926.1101 and post hazard warning signs at the doorway to the decontamination facility which shall be the only non-emergency entrance into the work areas. Post warning signs at all other potential access locations as indicated by the Owner's Representative.
  - J. The Contractor shall cover and protect electric panels and fixed equipment and objects.
  - K. The Contractor shall clean and decontaminate all surfaces inside the work area. Seal all openings and penetrations into work area.
  - L. Before commencing work within the work area, the Contractor shall inspect the work enclosure for breaches and smoke test for leaks, and any leaks shall be sealed properly.
  - M. The Contractor shall maintain emergency exits as required by regulating agencies for all work areas and mark with reflective tape or paint.

### 3.6 APPROVAL OF PREPARATION WORK:

After the work areas have been prepared according to plans pre-approved by the Owner's Representative, the Contractor shall request a formal site inspection by the Owner's Representative. No removal or other disturbance of asbestos-containing materials, dust, or debris shall occur until the Owner's Representative has inspected and approved the site preparation work in writing.

### 3.7 CLEANING OF CONTAMINATED SURFACES:

- A. This section pertains to the cleaning of surfaces, which are potentially contaminated with asbestos-containing dust and debris or discovered in the performance of the specified work. Such cleaning shall be required to prevent this dust from becoming airborne and posing an exposure risk to building occupants or interfering in air monitoring activities.

Cleaning actions shall be performed as preliminary exposure control procedures prior to performing other actions which are required.

Cleaning shall consist of HEPA-vacuuming followed by wet mopping of surfaces in a manner, which prevents dust generation, but effectively rids the surface of all visible debris, dust, film, and grime.

- B. Each HEPA vacuum cleaner shall be separately equipped with an airtight, securely attached hose, of proper length, and a collection wand, brush, and other special attachments appropriate to the required cleaning tasks. The equipment shall be properly always operated and shall contain no air leaks. The Owner's Representative shall inspect all vacuuming equipment prior to its use, and may request verification of the efficiency of the equipment's filtration.

### 3.8 REMOVAL PROCEDURES:

This section applies to removal of all materials containing contaminated or potentially contaminated with asbestos, as stated herein or as otherwise indicated by the Owner's Representative. All removal work shall be done using wet methods in such a way as to minimize the release of fibers, dust, or particulate into the air. All removal methods must be in accord with all Federal, State and local regulations and these specifications.

The Contractor is responsible for thoroughly cleaning one or more representative area(s) inside each contained area to the satisfaction of the Owner's Representative to be used by the Owner's Representative to establish a standard of cleanliness. Completion of removal stages must be approved by the Owner's Representative in writing.

The Contractor is responsible for protecting all previously cleaned and cleared areas throughout all abatement processes. The Contractor will clean and decontaminate all previously cleaned and cleared areas, which become contaminated during subsequent removal activities.

A. Removal of Ceramic and Floor Tiles, Base, Setting Bed and Related Mastic and Waterproofing Materials:

1. The Contractor is responsible for the removal and disposal of Ceramic and Floor Tile, Base, Setting Bed and Related Mastic and Waterproofing Materials.
2. The Contractor shall continually and thoroughly wet material.
3. The Contractor shall carefully remove materials from substrate, using hand-held or other suitable tools or equipment.
4. The Contractor shall promptly place materials in 6-mil polyethylene or other suitable bags or containers. Accumulation of debris inside the work area is prohibited.
5. The Contractor shall collect and pump all wastewater through a five (5) micron filter (multi-staged filtration system).
6. The Contractor shall dispose of all material in accordance with Section 02 82 40
7. The Contractor shall remove to clean substrate surface. Removal is complete only when clean surfaces remain.

B. Removal of Window and Door Caulking Materials:

1. The Contractor is responsible for the removal and disposal of the Window and Door Caulking Materials.
2. The Contractor shall continually and thoroughly wet material.
3. The Contractor shall carefully remove materials from substrate, using hand-held or other suitable tools or equipment.
4. The Contractor shall promptly place materials in 6-mil polyethylene or other suitable bags or containers. Accumulation of debris inside the work area is prohibited.
5. The Contractor shall collect and pump all wastewater through a five (5) micron filter (multi-staged filtration system).
6. The Contractor shall dispose of all material in accordance with Section 02 82 40
7. The Contractor shall remove to clean substrate surface. Removal is complete only when clean surfaces remain.

3.9 MATERIALS WHICH OWNER'S REPRESENTATIVE CLASSIFIES AS INACCESSIBLE FOR REMOVAL:

- A. The Contractor shall remove all specific materials unless he identifies to the Owner's Representative potentially inaccessible areas, and the Owner's Representative then so concurs and thereby classifies them as inaccessible. The Owner's Representative, however, may determine that materials can be made accessible by temporarily disconnecting and moving obstructing ductwork, cables, studding, plaster, pipes, conduits, or other mounted equipment and structures, in which case the Contractor shall remove and replace them at no additional cost.
- B. All areas that the Owner's Representative classifies as inaccessible shall be sealed and enclosed by the Contractor at no additional cost as follows:
  - 1. Seal all visible asbestos-containing materials with two (2) coats of approved penetrating spray encapsulates.
  - 2. Create an airtight enclosure around the area by installing sheet metal or wire lath secured with clamps or screws, and seal airtight with caulking.
  - 3. Mark all such sealed inaccessible asbestos-containing materials on a set of Drawings and transmit them to the Owner's Representative.
  - 4. Piping exiting the Work Areas – The remaining insulated piping open ends shall be sealed and wrapped with a permanent wrap.

3.10 OWNER'S REPRESENTATIVE'S APPROVAL OF REMOVAL WORK:

- A. Upon completion of removal work, but prior to commencing encapsulation or other final cleaning of the work area, the Contractor shall request the Owner's Representative to conduct an inspection and obtain written approval of the removal work.
- B. All materials shall be removed, gross debris cleaned up, wastewater collected and filtered, and waste bags removed from the Work Areas prior to the inspection.
- C. Any encapsulation or lock-down performed prior to the Owner's Representative's approval will require the Contractor to re-clean the entire work area to the satisfaction of the Owner's Representative.

3.11 CLEANING AND FINAL DECONTAMINATION:

This section applies to cleaning work areas where asbestos removal work has been performed. After all asbestos-containing or contaminated materials have been removed the Contractor shall remove all waste and perform a thorough multi-stage final cleanup



and decontamination of each work area per the methods indicated below. Completion of this stage of work must be approved by the Owner's Representative.

- A. Final clearance procedures of the work areas shall be performed only after all waste is packaged and removed, but prior to reinstalling any equipment or dismantling any barrier, decontamination facility, or protective coverings. Cleaning shall be subject to the Owner's Representative's approval based on visual inspections, surface dust-wipe tests, and air testing performed according to the AHERA standard. HEPA-exhaust systems shall operate continuously throughout the cleaning and air testing processes, exhausted to the building exterior, until the Owner's Representative authorizes their shutdown and removal from the site. The Contractor shall notify the Owner's Representative in writing at least 24 hours in advance of the expected completion time of final site clearance in order to allow the scheduling of clearance testing.
- B. Cleaning methods and approvals shall consist of the following steps performed in the listed order:
1. Remove all visible debris and particulate from protective coverings, scaffolding, floors, walls equipment, and all other surfaces. HEPA-vacuum all surfaces to pick up excess water and debris.
  2. Thoroughly clean all protective coverings, scaffolding, floors, walls, and equipment.
  3. The air in each work area shall then be lightly misted with amended water, and all protective coverings and other items in the work area shall be wiped thoroughly clean.
  4. After the Contractor has completed steps 1-3, he shall make a formal request to the Owner's Representative for a work area inspection. To facilitate scheduling of this inspection, the Contractor shall notify the Owner's Representative of the anticipated completion time of the above initial cleaning work 24 hours in advance.
  5. If the Owner's Representative observes any waste or debris in the work area during the inspection, the Contractor shall perform additional cleaning and decontamination as directed by the Owner's Representative.
  6. If the Owner's Representative approves this first cleaning, the Contractor shall remove slowly one layer of protective polyethylene covering surfaces inside the work area (except as indicated below) and shall package them in 6-mil waste bags. The waste bags shall be removed from the work area. Both layers of protective polyethylene in the decontamination facilities shall remain in place and in use.
  7. After these protective coverings are removed, the Work Area shall be completely wet wiped and HEPA-vacuumed.

8. Once the work area is completely dry, the Owner's Representative will perform an inspection of the Work Area.
9. Upon obtaining the Owner's Representative's written approval, the Contractor shall lock-down all surfaces within the Work Area. The Contractor may only lock down surfaces using encapsulates pre-approved by the Owner's Representative. The drying time shall be as specified by the manufacturer before clearance sampling is conducted.
10. If any of the post-cleaning clearance air or wipe sample results are above the pre-established clearance criteria, the Owner's Representative will require additional cleaning and decontamination of the work area, and the above inspection and clearance tests shall be repeated by the Owner's Representative.
11. After successful completion of the final air clearance testing, the Contractor shall carefully remove the protective coverings, decontamination facilities, and any temporary barrier walls or tunnels. The HEPA-exhaust systems shall be removed only after all other items are removed. A HEPA vacuum shall be kept on-site during this final disassembly work to cleanup any dust or debris.
12. Workers shall wear approved respiratory and personal protective equipment throughout all cleanup and waste disposal activities.

3.12 MONITORING AND TESTING: The performance and execution of this work is found in this Section, Air Monitoring - Test Laboratory Services.

3.13 AIR MONITORING BY CONTRACTOR:

- A. The Contractor shall be responsible for personnel air monitoring to document compliance of workers with the OSHA regulations using the methods as described in this Section, Air Monitoring - Test Laboratory Services.

3.14 FINAL INSPECTION AND TESTING:

- A. Following successful completion of the final visual inspection, the Contractor will be given written approval by the Owner's Representative to lock down each Work Area. When this is complete and after all visible dirt, dust, and grime has been removed from all surfaces in each Work Area, the Contractor shall notify the Owner's Representative that the workspace is ready for inspection and final air clearance testing. The Owner's Representative, with the assistance of the Contractor, shall visually inspect the workspace for the detection of any visible dust or contamination. If the visual inspection does not reveal any dust or other signs of contamination, final air testing shall commence. Approval of each Work Area for final air testing shall be obtained from Owner's Representative in writing.

The Contractor shall supply adequate lighting, scaffolding, ladders, and other necessary assistance during final visual inspection.

- B. Final air testing of the building interior will be conducted at the completion of each phase of work. The Contractor shall install engineering controls and barriers so as to isolate each area for final air clearance testing. Isolation barriers and access routes must be pre-approved in the Work Plan by the Owner's Representative.
- C. Final air testing (i.e., clean air certification) shall be performed pursuant to 40 CFR, Part 763, Appendix A, using Transmission Electron Microscopy (TEM), aggressive disturbance procedures, and continuous air circulation and HEPA-filtered exhaust. This shall be obtained by use of 1-horsepower leaf blowers (provided by Contractor) and the existing work area exhaust system, supplemented with 20-inch circulating fans (provided by Contractor and positioned where the Owner's Representative determines with smoke tubes that poor air circulation patterns exist). Work areas with less than 160 square feet or 260 Linear feet of asbestos-removal shall be considered complete following the passage of the visual inspection and final air testing via Phase Contrast Microscopy (PCM).
- D. The Contractor shall assist, as necessary, the Owner's Representative to accomplish safely and efficiently the aggressive disturbance and air circulation tasks. The Contractor also shall provide and install sufficient 15-amp, 120 v. (60-cyl) power lines for the Owner's Representative's air pumps evenly distributed in the work area, plus air pumps evenly distributed outside the work area. The Owner's Representative then shall collect all air clearance samples.
- E. The Contractor shall allow 24 hours for performance of aggressive disturbance procedures and collection of clearance air samples, and an additional 24 hours for laboratory TEM analyses of samples. Provisions will be made to perform PCM analysis on-site. The Contractor shall coordinate with the Owner's Representative to properly schedule clearance sampling and laboratory analysis.
- F. The aggressive disturbance procedures shall not commence until the Work Area is clean, all floor and wall polyethylene sheeting is removed, with all of the critical barriers in place, the lock down agent is completely dry, and the Work Area has been inspected and approved by the Owner's Representative.
- G. The final air testing shall take place under active agitation of the air in the workspace with the HEPA-filtered exhaust units operating. The Contractor shall also supply and operate additional circulating fans and leaf blowers as required and directed by the Owner's Representative during this final testing to ensure effective air circulation. The final test shall consist of collecting a minimum of thirteen (13) air samples for each testing to establish that contamination levels do not exceed 0.01 fibers per cubic centimeter (f/cc) and 70 structures per millimeter squared (s/mm<sup>2</sup>) of asbestos as determined by air sampling with analysis by Transmission Electron Microscopy.

- H. If all clearance criteria are not met, the Contractor shall perform a thorough wet cleaning and/or HEPA-vacuuuming as necessary and directed by the Owner's Representative to re-clean the work areas. The above clearance testing shall then be repeated by the Owner's Representative until clearance criteria are met. The Owner's Representative's charges to the Owner for this additional cleaning, inspection and air testing services shall be borne by the Contractor.
- I. After achieving the level of cleanliness and decontamination as specified herein and as confirmed by the final testing and checking, the Owner's Representative shall thoroughly inspect the space jointly with the Contractor to determine whether any damage has been done to the finishes, equipment, or any other part of the workspace.

A final inspection report shall be prepared jointly by the Owner's Representative and the Contractor detailing the list of items (punch list) to be fixed by the Contractor. Approval of final testing, checking, and ultimate completion shall be obtained from the Owner's Representative in writing.

### 3.15 RESPONSIBILITY FOR DAMAGES:

Any damages to the Site, items designated to remain, or adjacent property damage and disruption of operations of adjacent buildings and building occupants and uninvolved Site improvements, parking and drainage, that have been the result of actions by the Contractor's personnel or equipment, or subcontractors shall be repaired to safe working condition without any cost to the Owner.

END OF SECTION 02 82 10

## SECTION 02 82 40 – DISPOSAL OF ASBESTOS-CONTAINING MATERIALS

### PART 1.0 - GENERAL

#### 1.1 ASBESTOS WASTE DISPOSAL PROCEDURES:

- A. It is the responsibility of the Contractor to determine current waste handling, transportation, and disposal regulations for the work site and for each waste disposal landfill. The Contractor must comply fully with these regulations and all Department of Transportation and EPA requirements, and State and local regulations.
- B. The Contractor shall document actual disposal of the asbestos waste at the designated landfill certified by the State of Louisiana Department of Environmental Quality to accept asbestos waste. The Contractor shall document disposal by completing a written Disposal Form (Asbestos Disposal Verification Form - ADVF, Waste Shipment Record) which then shall be signed by the landfill operator upon receipt of materials. The original completed documentation shall be forwarded to the Owner's Representative. Approval of Contractor payment requests may be denied until receipt of such Disposal Certificates.
- C. Definition: Asbestos wastes are defined as all asbestos-containing or potentially asbestos-contaminated materials or other items which have not been cleaned completely to the satisfaction of the Owner's Representative while inside the Work Area, and which must be removed from the job site. Asbestos wastes may include building materials, insulation, disposable clothing and protective equipment, plastic sheeting and tape, contractor equipment, or other materials designated by State or local authorities or the Owner's Representative. All materials, clothing, equipment, supplies, exhaust system or vacuum filters, plastic sheeting and tape, and other materials designated by State or local authorities which potentially may be contaminated with asbestos, asbestos dust, or asbestos particulate must be disposed of as asbestos-containing or asbestos-contaminated wastes.
- D. Asbestos Waste Container Removal and Disposal Procedures:
  1. The costs for waste packaging, transportation, and approved landfill disposal (plus all related record keeping) shall be borne by the Contractor.
  2. The Contractor shall package, label, and remove all asbestos waste as specified in the above Sections. Packaging shall be accomplished in a manner that minimizes waste volume but insures waste containers shall not tear or break.
  3. The Owner's Representative must observe removal of all waste containers to verify their condition and certify the total volume of waste material (to the nearest cubic yard). He then shall insert the quantity on the Disposal Form/Waste Shipment Record and give the original of these

forms to the Contractor for transport to the landfill operator for signature.

## 1.2 WASTE REMOVAL SCHEDULING:

- A. All waste containers shall be decontaminated and removed from the site before final cleanup is started and isolation barriers are taken down. The Contractor must pre-schedule and obtain the approval of Owner's Representative for all time periods during which he desires to remove waste bags from the facility. Once a truckload of waste containers has accumulated, the Contractor shall arrange for transportation to the disposal site. Waste shall not be stored in the worker decontamination facility.
- B. Asbestos Waste Transportation and Disposal Regulations: It is the responsibility of the Contractor to determine and ensure that he is complying with 1) the current waste handling regulations applicable to each work site; and 2) the current regulations for transporting and disposing waste at each ultimate disposal landfill. He must comply fully with these regulations, and with all U.S. Department of Transportation, State, and EPA requirements.
1. The Contractor (or his subcontractor) at no additional cost shall maintain a valid solid waste transportation registration issued by the Louisiana State Department of Transportation; and obtain, complete, and fully comply with any other local hazardous waste manifesting requirements. A copy of any manifest forms shall be sent to the Owner's Representative after disposal is completed and all required data and signatures have been inserted.
  2. The Contractor shall provide a weight ticket to the Owner's Representative for each truckload of waste removed from the site.
  3. Waste hauling transportation methods shall comply with the provisions of EPA Title 40, Part 61, Subpart M, Louisiana Administrative Code, and Department of Transportation and with any hazardous waste regulations for temporary storage, transport, and disposal if such codes are enforced in states where the waste shall be stored, transported, or disposed of.

## PART 2.0 - PRODUCTS (NOT APPLICABLE)

## PART 3.0 - EXECUTION

### 3.1 ASBESTOS WASTE DISPOSAL:

- A. Asbestos Waste Packaging: All asbestos waste material shall be promptly placed in 6-mil clear polyethylene bags or other suitable containers lined with 6-mil polyethylene sheeting as it is generated. A sufficient number of waste bags shall be located in the immediate work area, and in the Equipment Room of the Worker Decontamination Facility, The Contractor shall count or measure the volume of each filled container leaving the work area and maintain a written

record of such.

- B. Asbestos Waste Labeling: Warning labels shall have waterproof print and permanent adhesive, in compliance with OSHA, EPA and DOT requirements, and shall be affixed to or printed on the sides of all waste bags or transfer containers. Warning labels shall be conspicuous and legible, and contain the following words:

DANGER  
CONTAMINATED ASBESTOS FIBERS  
AVOID CREATING DUST  
CANCER AND LUNG DISEASE HAZARD

AND

RQ HAZARDOUS  
SUBSTANCE  
SOLID, NOS  
ORM-E, NA 9188  
(ASBESTOS)

In addition, the Contractor shall prepare and affix to each waste container the following label in accordance with the NESHAP regulation:

HAZARDOUS WASTE  
FEDERAL LAW PROHIBITS IMPROPER DISPOSAL

IF FOUND, CONTACT THE NEAREST POLICE OR PUBLIC SAFETY AUTHORITY,  
OR THE U.S. ENVIRONMENTAL PROTECTION AGENCY

GENERATOR INFORMATION:

Generator's Name: Southern University Laboratory School

Generator's Address: Southern University Laboratory School  
129 Swan Avenue  
Baton Rouge La 70816

- C. Wetting of Asbestos Waste: A fine water spray shall be used to keep the top layers of waste in containers thoroughly wet at all times. When a waste container is full, it shall be securely sealed with tape or other secure fastener.
- D. Asbestos Waste Container Decontamination and Removal Procedures: The following procedures shall be followed whenever containers or equipment are removed from the Work Area:
1. The Clean Room shall be considered a holding area only during the period of active waste transfer for the purpose of the loading of carts or drums. Storage of waste and carts (or drums) in the Clean Room is

prohibited.

2. Waste removal shall not occur during worker shift changes or when workers are showering or changing. Care shall be taken to prevent short circuiting and cycling of air outward through the Shower Room and Clean Room when used for waste removal.
3. Workers are to be stationed in each room/area of the Decontamination Facility to transfer the containers and equipment to or from adjacent sections. These workers shall not cross the airlocks into the adjacent areas/rooms until the waste or equipment transfer is finished for that period and the workers have gone through decontamination as required by these specifications. The workers in the Clean Room or holding area shall enter from uncontaminated areas with appropriate personal protective equipment; or, prior to the start of waste transfer, these workers shall exit the Work Area, fully decontaminated, and subsequently don clean personal protective equipment.
4. External surfaces of contaminated containers and equipment shall be cleaned by wet cleaning and/or HEPA vacuuming in the Work Area before moving such items into the Decontamination Facility airlock. Workers shall not enter the airlock during this procedure.
5. The containers of waste and the equipment shall be removed from the airlock by workers stationed in the Washroom during waste removal operations.
6. Once in the Washroom, external surfaces of contaminated containers and equipment shall be cleaned a second time by wet cleaning.
7. The cleaned containers of waste and equipment shall be placed in uncontaminated leak-tight plastic bags, lined fiber drums or other lined containers (or 6-mil polyethylene sheeting if physical characteristics necessitate and permit). Air volumes shall be minimized, and the containers shall be sealed. Items that may puncture or tear plastic bags or sheeting shall be placed in a hard-wall container, such as a drum, and then sealed.
8. The clean re-containerized items shall be moved into the airlock for subsequent transfer to the holding area. The Washroom workers shall not enter this airlock or the work area until waste removal is finished for the period.
9. Re-containerized items and cleaned equipment shall be removed from the airlock to the holding area by workers who have entered from uncontaminated areas with appropriate personal protective equipment.
10. The re-containerized items of waste and cleaned equipment shall be placed in open top, watertight plastic carts or drums. These carts or drums shall be held in the holding area pending removal. The carts or



drums shall be HEPA-vacuumed or wet cleaned following the removal of the containers of waste from them.

11. The exit from the Decontamination Facility shall be monitored and always secured to prevent unauthorized entry.
  12. The carts/drums may be temporarily stored in a holding area at the work site outside the work area until a transport vehicle arrives, but such storage areas must be pre-approved by the Owner and the Owner's Representative.
- E. Asbestos Waste Container Storage: Sealed labeled containers may be temporarily stored in the Work Area, or in a pre-designated and approved outside area, until a truckload quantity is obtained. The storage temporary area must be completely enclosed with wood or metal walls, floors and ceilings lined with 6-mil polyethylene sheeting and must remain locked at all times except during active loading or unloading. The temporary storage area shall be identified prominently and posted with warning signs.

### 3.2 WASTEWATER DISPOSAL PROCEDURES

- A. All wastewater generated during the abatement work, including gross removal activities, final cleaning, and worker and equipment decontamination procedures must be completely collected by the Contractor and processed in accordance with all applicable Federal, State and local regulations, as well as with these specifications.
- B. Wastewater shall be collected continuously during abatement activities. The storage container shall be connected to a filtering system consisting of no fewer than two (2) filters in a series leading to a 5.0-micron final filter and an adequately sized pump, prior to disposal in a sanitary sewer. In the absence of a sanitary sewer system, the wastewater shall be drummed and transported to an approved landfill in accordance with the requirements for disposal. The Contractor shall not allow storage on the existing floor system unless verified by a Structural Engineer.
- C. Used water filters and other equipment and supplies used in the maintenance of the filtering system must be disposed of as asbestos-containing waste.
- D. The costs for wastewater filtration, storage, discharge, packaging, labeling, transport, and approved disposal (plus all related record keeping) shall be borne by the Contractor.

END OF SECTION 02 82 40

## SECTION 02 83 19 - REMOVAL AND DISPOSAL OF LEAD-CONTAINING PAINT

### PART 1.0 - GENERAL

#### 1.1 DESCRIPTION OF WORK:

- A. The Contractor shall remove, package, transport, and dispose of all lead-containing materials as necessary to remove in its entirety, in accordance with all Federal, State, and local rules and regulations. The Contractor is responsible for all costs associated with the removal, packaging, transporting, and disposal of these materials.
  
- B. The work, in general, includes, but is not limited to, the following:
  - 1. The Contractor shall remove the paint coatings from the window lintels, exterior and interior window Frame, all materials noted in Sheet Notes to be salvaged and turned over to the on-site Owner's storage for reuse.
  - 2. Removal and Disposal of Plaster Wall, and Ceiling. Windows, Doors and Frames coated with Lead-containing paint.
  - 3. Cleaning of any lead-containing paint contamination and lead-containing materials from ground surfaces including a 15-foot perimeter of the exterior of the building.
  - 4. Providing and implementing spill prevention control and countermeasure plans.
  - 5. Placement of all lead-contaminated items generated as a result of work activities into approved containers/drums.
  - 6. Conducting pre-disposal TCLP testing in the presence of the Owner/ Representative and 3<sup>rd</sup> Party Laboratory Analysis.
  - 7. Transportation of lead and lead-contaminated items and containers to the disposal site.
  - 8. Providing properly completed Waste Manifest/Waste Shipment Record Form.
  - 9. Provide name and location of disposal site.
  
- C. All lead-related work activities to be accomplished under this section shall be coordinated closely with asbestos abatement work to minimize potential toxic exposure.
  
- D. Prior to commencing this work, the Contractor shall inspect thoroughly the work area and prepare a construction schedule which lists anticipated time frames and sequence of operations for the various work activities. The construction schedule shall include activities such as contamination clean-up and removal of all Lead-

containing articles, items and containers from the work area. The construction schedule also shall include routing for all Lead-containing items to be removed from the work area and transported to disposal areas. Work activities, sequence of work, and routing scheme shall be transmitted to the Owner's Representative prior to the commencement of any work under this section.

- E. The Contractor shall furnish and maintain the electrical power and water to the site for the Contractors and Air Monitoring Firm's use and equipment.

## 1.2 APPLICABLE PUBLICATIONS:

- A. The applicable sections, latest editions, and addenda of the following governmental regulations, codes, industry standards, and recommended practices form a part of these specifications. Nothing in these specifications is to be construed as permitting work not conforming to these requirements:

1. USEPA - United States Environmental Protection Agency
2. NEC - National Electrical Code
3. NEMA - National Electrical Manufacturers Association
4. RCRA - Resource Conservation and Recovery Act
5. TSCA - Toxic Substances and Control Act
6. DOT - Department of Transportation
7. Louisiana Department of Environmental Quality
8. OSHA - Occupational Safety and Health Administration
9. NFPA - National Fire Protection Association
10. All other applicable Federal, State, Parish and city codes, standards and regulations.

- B. The Contractor is cautioned that he is responsible for ascertaining the extent to which these regulations affect the operations under these Contract Documents and to comply therewith.

1.3 DEFINITIONS: Refer to Section 02 82 10 for terms and definitions used in these Contract Documents.

1.4 SUBMITTALS: Refer to Section 02 82 10 for Contractor Submittal requirements.

1.5 RESPIRATORY AND PERSONNEL PROTECTION AND DECONTAMINATION: Refer to this Section for Contractor respiratory and personnel protection and decontamination requirements. Respirators with particulate/organic filtration, non-absorbent suits, gloves, and boots shall be worn while removing and handling materials.

- 1.6 WASTE DISPOSAL: Disposal by the Contractor. Refer to Paragraph 3.6 of this Section for Contractor waste disposal requirements.

## PART 2.0 - PRODUCTS

### 2.1 GENERAL REQUIREMENTS:

- A. The Contractor shall deliver all materials and equipment to the site in the original containers bearing the name of the manufacturer and details for proper storage and usage.
- B. All materials or equipment delivered to the site shall be unloaded, temporarily stored, and transferred to the Work Area in a manner which shall not interfere with operations of the building occupants. The Contractor shall not allow the storage containers on the existing floor system unless these loads are verified by a Structural Engineer as being acceptable.
- C. Unloading and temporary storage sites, and transfer routes, must be approved in advance by the Owner's Representative and the Owner.
- D. Damaged or deteriorated materials may not be used and must be promptly removed from the premises. Material which becomes contaminated with asbestos-containing material shall be packaged and legally disposed of in an approved landfill.
- E. Techniques, procedures, and equipment required by these specifications may be covered by one or more U.S. and/or foreign patents. It is the sole responsibility of the Contractor to determine what, if any, patents are applicable and to meet the requirements of the patent owner, including fees regarding the use of these patents.

### 2.2 MATERIALS, TOOLS, AND EQUIPMENT:

- A. All materials, tools, and equipment must comply, at a minimum, with this specification, and relevant Federal, State, and local codes. For the construction of containment barriers, work platforms, and decontamination facilities, all lumber and plywood shall be fire retardant. Flame-resistant polyethylene film shall conform to requirements set forth in the National Fire Protection Association, shall be fire-retardant, and shall bear manufacturer's stamp of Underwriters Laboratory Classification.

## PART 3.0 - EXECUTION

- 3.1 GENERAL: The requirements and sequences described herein are parameters for execution of the abatement work and do not include necessarily all abatement requirements. The Contractor will be responsible for all items that may be necessary to

complete the abatement work in accordance with the Contract Documents Work Plan, and all applicable regulations.

### 3.2 LEAD-PAINT REMOVAL/PRIMING:

- A. The Contractor shall prepare/contain the work area prior to commencing removal of lead-containing paint materials.
- B. The Contractor shall remove the damaged lead-containing paint on beams, columns, miscellaneous structural members and stairways, sand and smooth and prime with a ferrous metal primer, factory formulated rust inhibitive metal primer for exterior application; See paragraph 3.8 Primer.
- C. Once all of the lead-containing materials have been placed in the approved containers, the containers shall be decontaminated as necessary and placed in a lockable storage container.
- D. The Contractor shall arrange for and conduct pre-disposal TCLP Testing in the presence of the Environmental Consultant and Laboratory Analysis, and transportation of these materials to the disposal site in accordance with all Federal, State, and local rules and regulations (as required).

### 3.3 SPILL CLEAN-UP, CONTAINERIZATION AND MARKING:

- A. Equipment and Tools: After the lead-containing paint has been separated from the structural steel, all tools and equipment used in the work shall be decontaminated and properly stored. Where work surfaces have contacted Lead-containing paint fluids, they shall be scraped clean, flushed with solvent, wiped clean, and all debris placed in approved drums and properly disposed of. All tools that may have come in contact with Lead-containing paint at any concentration shall be thoroughly cleaned.
- B. Roof and Steel Structures: All roof steel surfaces that may have come in contact with Lead-containing paint, either during the course of work activities or due to past peeling or deterioration, shall be removed, cleaned thoroughly and wiped clean sanded and smooth and primed.

### 3.4 CONTAINERIZATION AND MARKING:

- A. All debris and materials generated as a result of work activities and clean-up operations shall be placed in closed top drums and sealed with a steel ring band with bolt compression device. All solids, such as rags, disposable protective clothing, and other incidentals, shall be placed in closed top drums and sealed with a steel ring band with bolt compression device.
- B. All drums and Lead containing containers (where used) shall be permanently marked as to specific contents and dated in accordance with Federal, State and local rules and regulations. In addition, each drum (and container) shall be sealed with a steel ring band with bolt compression device.

3.5 LEAD-CONTAINING DEBRIS: If a lead-containing debris spill occurs, the Contractor shall implement the emergency spill plan procedures.

- A. The Contractor shall limit the airborne Lead concentration of the air to below 30 microgram per cubic meter of air (30 ug/m<sup>3</sup>) or the background level before the start of the project, whichever is lower.
- B. The Contractor shall limit the Lead concentration of building surfaces to below 800 micrograms per square foot, (800ug/ft<sup>2</sup>).
- C. If required, air monitoring data shall include the sorbent type, sampling rate, sampling volume, analytical method, amount of lead-containing paint detected, and limit of detection, as per NIOSH analytical methods. Surface monitoring shall include the filter type, sorbent type, sampling, location area sampled, analytical method, amount of lead-containing paint detected and the limit of detection, as per NIOSH analytical Method 5503. Analytical results for lead analysis shall be provided to the Owner's Representative within 24 hours of the end of work on any weekend or within 24 hours of the removal of the material.

3.6 HANDLING AND TRANSPORTATION TO OFF-SITE DISPOSAL FACILITIES:

- A. Handling of Drums: All closed top drums must be sealed and marked prior to loading on the transport vehicle. Filled drums shall be loaded on the transport vehicle by any of the following methods:
  - 1. By a hoist or lift truck utilizing a two-point drum lifter.
  - 2. By a lift truck lifting the drums from underneath by a pallet attached to the drum by a banding arrangement.
- B. Drums shall not be lifted by any rope, chain or cloth slings tied about the drum, placement of drums on bare-lift truck forks, forcing drums between forks of a lift truck, or any commercial drum lift exerting force on the sides of a drum.
- C. All drums or Lead-containing article containers shall be secured to the transport vehicle to prevent movement in transit.
- D. All Lead-containing articles and all drums containing solids and incidentals shall be disposed of in accordance with Federal and State regulations.
- E. The Contractor shall utilize a Waste Hauler Contractor licensed for the transportation and hauling of Lead-containing hazardous wastes. The firm shall provide a routing plan which clearly identifies the routes he proposes to follow while transporting Lead-containing items from the various work areas (points of generation) to the disposal site. A minimum of two operators shall attend all times when Lead-containing items are being loaded and unloaded.
- F. Vehicles used for transporting of Lead-containing items must be marked plainly and visibly in accordance with Federal, State and local rules and regulations.

- G. Unloading, Records, and Placement in Storage: Transport vehicles shall be unloaded utilizing the same equipment and methods as for loading. Immediately following unloading of the Lead-containing transport vehicle, the cargo area shall be inspected to check for any fluid leaks. If any fluid leaks are found, the source of the leaking drum or item shall be identified and sealed. The contaminated cargo area shall be thoroughly cleaned. Cleaning solvents and solids shall be placed in proper drums.
- H. Upon completion of all Lead removal work related activities, the Contractor shall provide a complete record of such activities and incinerator data to the Owner's Representative. The record shall include but not be limited to:
1. Name of the Contractor performing the work outlined in this Section and the technician-in-charge.
  2. Lead-containing paint removed:
    - a. Date removed from service and location.
    - b. Date of incineration.
    - c. Weight in kilograms.
  3. Drums and Lead-containing paint article containers (where applicable):
    - a. Drum size (30 or 55 gallons).
    - b. Identification of contents, etc., for solids, rags, sorbents, etc.
    - c. Weight in kilograms of contents of each drum (or container).
    - d. Date items were destroyed and location and company.
  4. Hazardous Waste Manifests/Waste Shipment Record Form and Chain-of-Custody Forms shall be provided for all hazardous waste materials, and hazardous waste manifests shall be presented to the Owner's Representative.

### 3.7 SAFETY PROCEDURES AND WORKER PROTECTION:

- A. All required precautions and measures shall be taken to protect employees, related trade employees, inspection personnel, and the public from exposure to Lead-containing paint solids and vapors. (The Contractor shall follow procedures similar to those utilized when handling asbestos containing material and as described herein; see Section 02 82 10 Removal of Asbestos-Containing Materials).

- B. Work Area Protection and Marking: Prior to commencing any Lead-related work activities, barricades and warning signs shall be provided to identify clearly and guard effectively against unauthorized entry into the work area.
- C. All equipment shall be confined to the work area until the work is complete, and containers are sealed, and equipment properly and safely stored for transport.
  - 1. Barricades: If approved asbestos-related temporary enclosures are in use, no additional Lead-related temporary enclosures need to be constructed, except as needed in case of Lead-related emergency,
  - 2. Signs: During the Lead work phase, the Contractor shall place warning signs at intervals of approximately ten feet. The warning signs for work areas shall be approximately one foot six inches square with a yellow background and one-inch black letters.
- D. Protective measures shall be provided in connection with the transport of Lead-containing materials within the building over for the entire pathway to the exterior elevators to the transporting vehicle.
- E. Protective Clothing and Equipment: At all times when Lead-containing materials in any volume are not sealed in drums, containers, or electrical equipment, workers shall wear:
  - 1. Disposable, nonporous gloves.
  - 2. Disposable whole-body clothing impermeable to Lead.
  - 3. Respiratory protection (NIOSH/MSHA-approved) against Lead vapors and particulates (at least the level of particulate protection required at that stage of work for asbestos protection).
  - 4. Eye protection.
  - 5. Hard hats.
- F. The Contractor shall provide protective clothing, eye protection, and respiratory protection as required for inspection personnel monitoring work activities within the work area.
- G. Personnel Protection and Procedures: The Lead work area shall at no time be left unattended after procedures have begun and until all materials and incidentals have been sealed in approved, properly labeled containers. If immediate transportation to the Lead incineration facility is not feasible, the Work Area must be secured in a manner in accordance with Federal, State and local rules and regulations. During procedures and at all times when lead-containing materials and debris in any volume are not sealed in drums, containers, or electrical equipment, all personnel entering the work area must don protective clothing and equipment as listed herein. Upon exiting the work area, all



disposable protective clothing shall be placed in approved drums, sealed, and disposed of as specified herein.

- H. Workers with cuts or scratches shall protect against these wounds before entering the work area. Similarly, workers who accidentally incur minor cuts or scratches in the course of work activities shall leave the work area, cleanse the wound with medical grade soap, and seal the wound before returning to the work area.
- J. The Contractor shall develop a sequenced plan for the completion of all Lead-related work and submit this plan in advance of such work to the following Owner's Representative. The plan shall address the following items:
  - 1. Lists of vehicles, equipment, and personnel to be used in accomplishing the work.
  - 2. The emergency spill plan, which shall encompass all steps the Contractor will take in the event of a spill or other emergency.
  - 3. Safety procedures, which shall cover all phases of operations, including but not limited to, handling, loading, transporting, securing Lead-containing paint, and first aid procedures.

### 3.8 PRIMER

- A. The Contractor shall remove the lead-containing paint from beams, columns and stairway surfaces, and all materials noted in the Sheet Notes on the drawings and in Selected Interior Demolition Section, sand and prime with a ferrous metal primer, factory formulated rust inhibitive metal primer for exterior application; Benjamin Moore, IMC Alkyd Metal Primer No. M06, applied at a dry film thickness of not less than 2.0 mils; Coronado, 35-147 Rust Scat Alkyd Metal Primer, applied at a dry film thickness of not less than 2.0 mils; Dulux Paint, 4160-xxxx Devguard Multi-Purpose Tank and Structural Primer, applied at a dry film thickness of not less than 2.0 mils; Pittsburgh Paints, 90-712 Pitt-Tech One Pack Interior/Exterior Primer Finish DTM Industrial Enamel, applied at a dry film thickness of not less than 3.0 mils; or Sherwin-Williams, Kem Kromik Universal Metal Primer B50Nz6/B50Wz1, applied at a dry film thickness of not less than 3.0 mils.

END OF SECTION 02 83 19

## SECTION 02 84 30 - REMOVAL OF POLYCHLORINATED BI PHENYLS (PCB-CONTAINING) BALLASTS

### PART 1.0 - GENERAL

#### 1.1 DESCRIPTION OF WORK:

- A. The Contractor shall remove, package, transport, and dispose of all PCB-containing ballasts from fluorescent light fixtures located in the ceiling grid (ONLY FOR OLDER FLUORESCENT FIXTURES NOT SCHEDULED TO BE REUSED)., in accordance with all Federal, State, and local rules and regulations. The Contractor is responsible for all the costs associated with the removal, packaging, transporting, and disposal of these ballasts.
- B. The work, in general, includes, but is not limited to, the following:
  - 1. Dismantling light fixtures and separation of ballasts to permit removal. Dispose of the remaining fixture as construction debris (ONLY FOR OLDER FLUORESCENT AND RECESSED CEILING FIXTURES NOT SCHEDULED TO BE REUSED).
  - 2. Cleaning of any PCB contamination on fixtures surfaces.
  - 3. Providing and implementing spill prevention control and countermeasure plans.
  - 4. Placement of all PCB contaminated items generated as a result of work activities into approved containers/drums.
  - 5. Transportation of PCB's and PCB-contaminated items and containers to the disposal site.
  - 6. Providing properly completed Waste Manifest/Waste Shipment Record Form.
  - 7. Provide name and location of disposal site.
- C. All PCB-related work activities to be accomplished under this section shall be coordinated closely with asbestos abatement work to minimize potential toxic exposure.
- D. Prior to commencing this work, the Contractor shall inspect thoroughly the work area and prepare a construction schedule which lists anticipated time frames and sequence of operations for the various work activities. The construction schedule shall include activities such as contamination clean up and removal of all PCB-containing articles, items, and containers from the work area. The construction schedule also shall include routing for all PCB-containing items to be removed from the work area and transported to disposal areas. Work activities, sequence of work, and routing scheme shall be transmitted to the Designer prior to the commencement of any work under this section.

## 1.2 APPLICABLE PUBLICATIONS:

- A. The applicable sections, latest editions, and addenda of the following governmental regulations, codes, industry standards, and recommended practices form a part of these specifications. Nothing in these specifications is to be construed as permitting work not conforming to these requirements:
1. USEPA - United States Environmental Protection Agency
  2. NEC - National Electrical Code
  3. NEMA - National Electrical Manufacturers Association
  4. RCRA - Resource Conservation and Recovery Act
  5. TSCA - Toxic Substances and Control Act
  6. DOT - Department of Transportation
  7. Louisiana Department of Environmental Quality
  8. OSHA - Occupational Safety and Health Administration
  9. NFPA - National Fire Protection Association
  10. All other applicable Federal, State, Parish and city codes, standards and regulations.
- B. The Contractor is cautioned that he is responsible for ascertaining the extent to which these regulations affect the operations under these Contract Documents and to comply therewith.

1.3 DEFINITIONS: Refer to Section 02 82 10 for terms and definitions used in these Contract Documents.

1.4 SUBMITTALS: Refer to Section 02 82 10 for Contractor Submittal requirements.

1.5 RESPIRATORY AND PERSONNEL PROTECTION AND DECONTAMINATION: Refer to Paragraph 3.7 of the Section for Contractor respiratory and personnel protection and decontamination requirements. Respirators with particulate/organic filtration, non-absorbent suits, gloves, and boots shall be worn while removing and handling ballasts.

1.6 WASTE DISPOSAL: Disposal by the Contractor. Refer to Paragraph 3.6 of this Section for Contractor waste disposal requirements.

## PART 2.0 - PRODUCTS

### 2.1 GENERAL REQUIREMENTS:

- A. The Contractor shall deliver all materials and equipment to the site in the original containers bearing the name of the manufacturer and details for proper storage and usage.
- B. All materials or equipment delivered to the site shall be unloaded, temporarily stored, and transferred to the Work Area in a manner which shall not interfere with the operations of the building occupants.
- C. Unloading and temporary storage sites, and transfer routes, must be approved in advance by the Designer.
- D. Damaged or deteriorated materials may not be used and must be promptly removed from the premises. Material which becomes contaminated with asbestos-containing material shall be packaged and legally disposed of in an approved landfill.
- E. Techniques, procedures, and equipment required by these specifications may be covered by one or more U.S. and/or foreign patents. It is the sole responsibility of the Contractor to determine what, if any, patents are applicable and to meet the requirements of the patent owner, including fees regarding the use of these patents.

## 2.2 MATERIALS, TOOLS, AND EQUIPMENT:

- A. All materials, tools, and equipment must comply, at a minimum, with this specification, and relevant Federal, State, and local codes. For the construction of containment barriers, work platforms, and decontamination facilities, all lumber and plywood shall be fire retardant. Flame-resistant polyethylene film shall conform to requirements set forth in the National Fire Protection Association, shall be fire-retardant, and shall bear manufacturer's stamp of Underwriters Laboratory Classification.

## PART 3.0 – EXECUTION\_(ONLY FOR OLDER FLUORESCENT FIXTURES NOT SCHEDULED TO BE REUSED).

- 3.1 GENERAL: The requirements and sequences described herein are parameters for execution of the abatement work and do not necessarily include all abatement requirements. The Contractor will be responsible for all items that may be necessary to complete the abatement work in accordance with the Contract Documents Work Plan, and all applicable regulations.

## 3.2 PCB-BALLAST REMOVAL:

- A. The Contractor shall remove the ballasts from the fluorescent fixtures in a well-ventilated Work Area. The ballasts shall be removed from the fixtures and placed

in layers. A layer of absorbent material more than the contained liquid shall be placed between each layer of ballasts.

- B. Once all the ballast has been placed in the approved drums, the drums shall be decontaminated as necessary and placed in a lockable storage container.
- C. The Contractor shall arrange for transportation to the disposal site in accordance with all Federal, State, and local rules and regulations.

### 3.3 SPILL CLEAN-UP, CONTAINERIZATION AND MARKING:

- A. **Equipment and Tools:** After the last ballast has been separated from the electrical fixture, all tools and equipment used in the work shall be decontaminated and properly stored. Where work surfaces have contacted PCB fluids, they shall be scraped clean, flushed with solvent, wiped clean, and all debris placed in approved drums and disposed of in an EPA-approved incinerator. All tools that may have come in contact with PCBs at any concentration shall be thoroughly cleaned.
- B. **PCB Articles (Electrical Equipment):** All exterior surfaces of electrical equipment to be removed that may have come in contact with PCB's or contaminated oils or fluids, either during the course of work activities or due to past leaks, shall be cleaned thoroughly and wiped clean.
- C. **Slabs, Floors, and Walls:** All concrete (or other surfaces) which have come in contact with PCB's or PCB mixtures in the course of the work as a result of past leaks shall be cleaned thoroughly using a combination of sorbents, solvents, and cleaners.

### 3.4 CONTAINERIZATION AND MARKING:

- A. All liquids generated as a result of work activities and clean-up operations shall be placed in closed top drums and sealed with a steel ring band with bolt compression device. All solids, such as sorbents, rags, disposable protective clothing, and other incidentals, shall be placed in closed top drums and sealed with a steel ring band with bolt compression device.
- B. All drums and PCB article containers (where used) shall be permanently marked as to specific contents and dated in accordance with Federal, State, and local rules and regulations. In addition, each drum (and container) shall be sealed with a steel ring band with bolt compression device.

### 3.5 PCB RELEASE LIMITS: If a PCB spill occurs, the Contractor shall implement the emergency spill plan procedures.

- A. The Contractor shall limit the airborne PCB concentration to below one (1) microgram per cubic meter of air ( $1\mu\text{g}/\text{c}^3$ ) or the background level before the start of the project, whichever is lower.
- B. The Contractor shall limit the PCB concentration of building surfaces to below 10 micrograms per 100 square centimeters, ( $10\mu\text{g}/100\text{cm}^2$ ).
- C. If required, air monitoring data shall include the sorbent type, sampling rate, sampling volume, analytical method, mass of PCB's detected, and limit of detection, as per NIOSH analytical methods. Surface monitoring shall include the filter type, sorbent type, sampling, location area sampled, analytical method, mass of PCB's detected and the limit of detection, as per NIOSH analytical Method 5503. Analytical results for PCB analysis shall be provided to the Owner's Representative within 24 hours of the end of work on any weekend or within 24 hours of the removal of the ballasts.

### 3.6 HANDLING AND TRANSPORTATION TO OFF-SITE DISPOSAL FACILITIES:

- A. Handling of Drums: All closed top drums must be sealed and marked prior to loading on the transport vehicle. Filled drums shall be loaded on the transport vehicle by any of the following methods:
  - 1. By hoist or lift truck utilizing a two-point drum lifter.
  - 2. By a lift truck lifting the drums from underneath by a pallet attached to the drum by a banding arrangement.
- B. Drums shall not be lifted by any rope, chain or cloth slings tied about the drum, placement of drums on bare-lift truck forks, forcing drums between forks of a lift truck, or any commercial drum lift exerting force on the sides of a drum.
- C. All drums or PCB article containers shall be secured to the transport vehicle to prevent movement in transit.
- D. The Contractor shall utilize a Waste Hauler Contractor licensed for the transportation and hauling of PCB hazardous wastes. The firm shall provide a routing plan which clearly identifies the routes he proposes to follow while transporting PCB items from the various work areas (points of generation) to the disposal site. A minimum of two operators shall be in attendance at all times when PCB items are being loaded and unloaded.
- E. Vehicles used for transporting PCB items must be marked plainly and visibly in accordance with Federal, State and local rules and regulations.
- F. Unloading, Records, and Placement in Storage: Transport vehicles shall be unloaded utilizing the same equipment and methods as for loading. Immediately following unloading of the PCB transport vehicle, the cargo area shall be inspected to check for any fluid leaks. If any fluid leaks are found, the source of the leaking drum or item shall be identified and sealed. The contaminated cargo

area shall be thoroughly cleaned. Cleaning solvents and solids shall be placed in proper drums.

- G. Upon completion of all PCB work-related activities, the Contractor shall provide a complete record of such activities and incinerator data to the Owner's Representative. The record shall include but not be limited to:
1. Name of the Contractor performing the work outlined in this Section and the technician-in-charge.
  2. Ballasts and Electrical Equipment removed:
    - a. Manufacturer, serial number, and date of Manufacture.
    - b. Date removed from service and location.
    - c. Date of incineration.
    - d. Weight in pounds.
  3. Drums and PCB article containers (where applicable):
    - a. Drum size (30 or 55 gallons).
    - b. Identification of contents, i.e., ballasts, cleaning solvents, etc., for solids, rages, sorbents, etc.
    - c. Weight in kilograms of contents of each drum (or container).
    - d. Date items were destroyed and location and company.
  4. Hazardous Waste Manifests/Waste Shipment Record Form and Chain-of-Custody Forms shall be provided for all hazardous waste materials, and hazardous waste manifests shall be presented to the Owner's Representative.

### 3.7 SAFETY PROCEDURES AND WORKER PROTECTION:

- A. All required precautions and measures shall be taken to protect employees, related trade employees, inspection personnel, and the public from exposure to PCB solids, liquids, and vapors.
- B. All electrical equipment upon which PCB-related activities are to be performed shall be disconnected permanently from any power source prior to commencing of any work.

- C. Work Area Protection and Marking: Prior to commencing any PCB-related work activities, barricades and warning signs shall be provided to identify clearly and guard effectively against unauthorized entry into the work area.
- D. All equipment shall be confined to the work area until the work is complete, and containers are sealed and equipment properly and safely stored for transport.
  - 1. Barricades: If approved asbestos-related temporary enclosures are in use, no additional PCB-related temporary enclosures need to be constructed, except as needed in case of PCB-related emergency,
  - 2. Signs: During the PCB work phase, the Contractor shall place warning signs at intervals of approximately ten feet. The warning signs for work areas shall be approximately one foot six inches square with a yellow background and one-inch black letters. Signs shall read: "DANGER - KEEP OUT - TOXIC CHEMICAL WORK AREA."
- E. Protective measures shall be provided in connection with the transport of PCB materials within the building over for the entire pathway to the exterior elevators to the transporting vehicle.
- F. Protective Clothing and Equipment: At all times when PCB materials in any volume are not sealed in drums, containers, or electrical equipment, workers shall wear:
  - 1. Disposable, nonporous gloves.
  - 2. Disposable whole-body clothing impermeable to PCBs.
  - 3. Respiratory protection (NIOSH/MSHA-approved) against organic vapors and particulates (at least the level of particulate protection required at that stage of work for asbestos protection).
  - 4. Eye protection.
  - 5. Hard hats.
- G. The Contractor shall provide protective clothing, eye protection, and respiratory protection as required for inspection personnel monitoring work activities within the work area.
- H. Personnel Protection and Procedures: The PCB work area shall at no time be left unattended after procedures have begun and until all ballasts and incidentals have been sealed in approved, properly labeled containers. If immediate transportation to the PCB incineration facility is not feasible, the Work Area must be secured in a manner in accordance with Federal, State, and local rules and regulations. During procedures and at all times when PCB ballasts or mixtures in any volume are not sealed in drums, containers, or electrical equipment, all personnel entering the work area must don protective clothing and equipment as



listed herein. Upon exiting the work area, all disposable protective clothing shall be placed in approved drums, sealed, and disposed of as specified herein.

- I. Workers with cuts or scratches shall protect these wounds before entering the work area. Similarly, workers who accidentally incur minor cuts or scratches in the course of work activities shall leave the work area, cleanse the wound with medical grade soap, and seal the wound before returning to the work area.
- J. The Contractor shall develop a sequenced plan for the completion of all PCB related work and submit this plan in advance of such work to the following Owner's Representative. The plan shall address the following items:
  1. Lists of vehicles, equipment, and personnel to be used in accomplishing the work.
  2. The emergency spill plan, which shall encompass all steps the Contractor will take in the event of a spill or other emergency.
  3. Safety procedures, which shall cover all phases of operations, including but not limited to, handling, loading, transporting, securing PCB loads, and first aid procedures.

END OF SECTION 02 84 30

## SECTION 02 85 00 - REMOVAL OF MERCURY CONTAINING FLUORESCENT LIGHT TUBES

### PART 1.0 - GENERAL

#### 1.1 DESCRIPTION OF WORK:

- A. The Contractor shall remove, package, transport, and dispose of the mercury vapor-containing fluorescent light tubes (lamps) from fluorescent light fixtures throughout the building (ONLY FOR OLDER FLUORESCENT FIXTURES AND RECESSED CEILING FIXTURES, NOT SCHEDULED TO BE REUSED), in accordance with all Federal, State, and local rules and regulations. The Contractor is responsible for all the costs associated with the removal, packaging, and transportation and disposal.
- B. The work, in general, includes, but is not limited to, the following (ONLY FOR OLDER FLUORESCENT FIXTURES AND RECESSED CEILING FIXTURES, NOT SCHEDULED TO BE REUSED):
  - 1. Partial dismantling of light fixtures and separation of lamps to permit removal.
  - 2. Cleaning of any PCB or asbestos contamination on fixtures surfaces.
  - 3. Providing and implementing spill prevention control and countermeasure plans.
  - 4. Placement of the light tubes generated as a result of work activities, into approved containers/drums.
  - 5. Transportation of the light tubes to the off-site recycling facility.
  - 6. Provide properly completed Waste Manifest Form/Waste Shipment Record.
  - 7. Provide name and location of recycling facility (or disposal facility) licensed to accept this waste.
- C. All work activities to be accomplished under this section shall be closely coordinated with asbestos abatement work to minimize potential toxic exposure.
- D. Prior to commencing this work, thoroughly inspect the Work Area and prepare a construction schedule, which lists anticipated time frames and sequence of operations for the various work activities. The construction schedule shall include activities such as contamination clean up, and removal of fluorescent lamps from the work area. The construction schedule shall also include routing for items to be removed from the Work Area and transported to the Disposal Site. Work activities, sequence of work, and routing scheme shall be transmitted to the Designer prior to the commencement of any work under this section.

## 1.2 APPLICABLE PUBLICATIONS:

- A. The applicable sections, latest editions and addenda of the following government regulations, codes, industry standards and recommended practices, form a part of these specifications. Nothing in these specifications is to be construed as permitting work not conforming to these requirements:
1. USEPA - United States Environmental Protection Agency
  2. NEC - National Electrical Code
  3. NEMA - National Electrical Manufacturers Association
  4. RCRA - Resource Conservation and Recovery Act
  5. TSCA - Toxic Substances and Control Act
  6. DOT - Department of Transportation
  7. Louisiana Department of Environmental Quality
  8. OSHA - Occupational Safety and Health Administration
  9. NFPA - National Fire Protection Association
  10. All other applicable Federal, State, Country and city codes, standards and regulations.

The Contractor is cautioned that he is responsible for ascertaining the extent to which these regulations affect the operations under these Contract Documents and to comply therewith.

## 1.3 DEFINITIONS:

- A. Refer to Section 02 82 10 for terms and definitions used in these Contract Documents.

## 1.4 SUBMITTALS:

- A. Refer to Section 02 82 10 and this Section for Contractor Submittal requirements.

## 1.5 RESPIRATORY AND PERSONNEL PROTECTION AND DECONTAMINATION:

- A. Refer to paragraph 3.6 of this Section for Contractor respiratory and personnel protection and decontamination requirements.

## 1.6 WASTE DISPOSAL:

- A. Refer to Paragraph 3.5 of this Section for Contractor waste disposal requirements.

## PART 2.0 - PRODUCTS

### 2.1 GENERAL REQUIREMENTS:

- A. The Contractor shall deliver all materials and equipment to the site in the original containers bearing the name of the manufacturer, and details for proper storage and usage.
- B. All materials or equipment delivered to the site shall be unloaded, temporarily stored, and transferred to the Work Area in a manner which shall not interfere with the operations of the building occupants.
- C. Unloading and temporary storage sites, and transfer routes, must be approved in advance by the Designer.
- D. Damaged or deteriorated materials may not be used and must be promptly removed from the premises.
- E. Techniques, procedures, and equipment required by these specifications may be covered by one or more U.S. and/or foreign patents. It is the sole responsibility of the Contractor to determine what, if any, patents are applicable and to meet the requirements of the patent owner including fees regarding the use of these patents.

### 2.2 MATERIALS, TOOLS, AND EQUIPMENT:

- A. All materials, tools, and equipment must comply at a minimum with this specification, and relevant Federal, State, and local codes. For the construction of containment barriers, work platforms, and Decontamination Facilities, all lumber and plywood shall be fire retardant. Flame resistant polyethylene film shall conform to requirements set forth in the National Fire Protection Association, shall be fire retardant, and shall bear manufacturer's stamp of UL Classification.

## PART 3.0 – EXECUTION

### 3.1 GENERAL:

- A. The requirements and sequences described herein are execution parameters for the removal work and do not necessarily include all removal requirements. The Contractor will be responsible for all items that may be necessary to complete the removal work in accordance with the Work Plan, Scope of Work, and all applicable regulations.

### 3.2 SPENT FLUORESCENT LAMP REMOVAL:

- A. The Contractor shall remove the lamps from the fluorescent fixtures in a well-ventilated Work Area. The lamps shall be removed from the fixtures and placed

in approved containers or barrels. Containers shall be constructed in a manner that will permit the transportation of the lamps without breakage.

- B. Once all of the lamps have been placed in the approved containers, the containers shall be decontaminated as necessary and placed in a lockable storage container.
- C. The Contractor shall arrange for transportation to the disposal site.

### 3.3 SPILL CLEAN-UP, CONTAINERIZATION AND MARKING:

- A. Clean up of Work Area:
  - 1. Equipment and Tools: After the last lamp has been separated from the electrical fixture, all tools and equipment used in the work shall be decontaminated and properly stored.

### 3.4 CONTAINERIZATION AND MARKING:

- A. All lamps generated as a result of work activities and clean-up operations shall be placed in the approved containers and placed in a lockable storage container to be transported to the pre-approved disposal facility.
- B. All containers shall be permanently marked as to specific contents and dated in accordance with Federal, State and local rules and regulations.

### 3.5 HANDLING AND TRANSPORTATION TO OWNER'S OFF-SITE/TEMPORARY STORAGE AREA:

- A. Handling of Containers: All containers shall be sealed and marked prior to loading on the transport vehicle. Containers shall be loaded on the transport vehicle by any of the following methods:
  - 1. By hoist or lift truck utilizing a two-point drum lifter.
  - 2. By a lift truck lifting the drums from underneath by a pallet attached to the drum by a banding arrangement.
- B. Containers shall not be lifted by: Any rope, chain or cloth slings tied about the container, placement of containers on bare-lift truck forks, forcing container between forks of a lift truck, or any commercial container lift exerting force on the sides of a container.
- C. All containers shall be secured to the transport vehicle to prevent movement in transit.
- D. All lamps shall be transported to the pre-approved disposal facility.

- E. The Contractor shall utilize a waste hauler licensed for the transportation and hauling of hazardous wastes. The Contractor shall provide a routing plan, which clearly identifies the routes proposed to follow from the Work Area (points of generation) to the Owner's off-site temporary storage area. A minimum of two operators shall be in attendance at all times when items are being loaded and unloaded.
- F. Vehicles used for transporting lamps must be plainly and visibly marked in accordance with Federal, State and local rules and regulations.
- G. Unloading, Records, and Placement in Storage: Transport vehicles shall be unloaded utilizing the same equipment and methods as for loading.
- H. Upon completion of all work-related activities, the Contractor shall provide a complete record of such activities to the Owner's Representative. The record shall include but not be limited to:
  - 1. Name of the Contractor performing the work outlined in this Section and technician in charge.
  - 2. Lamps removed:
    - a. Date removed from service and location
    - b. Number of lamps
  - 3. Containers:
    - a. Container size and type.
    - b. Identification of contents.
    - c. Weight in kilograms of contents of the container and number of containers.
    - d. Date items were transported to pre-approved disposal facility.
  - 4. Completed Waste Manifest Form/Waste Shipment Records and Chain-of-Custody Forms shall be presented to the Owner's Representative within three days from the time the lamps are transported to the disposal site and included within the close out report

### 3.6 SAFETY PROCEDURES AND WORKER PROTECTION:

- A. Take all precautions and measures required to protect employees, related trade employees, inspection personnel, and the public from exposure to mercury vapor and glass.
- B. All electrical equipment upon which related activities are to be performed shall be

- permanently disconnected from any power source prior to commencing any work.
- C. Work Area Protection and Marking: Prior to commencing any work activities, provide barricades and warning signs to clearly identify and effectively guard against unauthorized entry into the Work Area.
- D. All equipment shall be confined to the Work Area until the work is complete and containers are sealed, and equipment properly and safely stored for transport.
1. Barricades: If approved asbestos-related temporary enclosures are in use, no additional enclosures need to be constructed.
  2. Signs: During this work phase, the Contractor shall place warning signs at intervals of approximately ten feet, warning signs. The warning signs for Work Areas shall be approximately one foot six inches square with a yellow background and one-inch black letters. Signs shall read: "DANGER - KEEP OUT - TOXIC CHEMICAL WORK AREA. "If approved asbestos-related temporary enclosures are in use, no additional signs are needed.
- E. Protective measures shall be provided for the transporting of materials within the building for the entire pathway to the exterior elevators to transporting vehicle.
- F. Protective Clothing and Equipment: When handling fixtures and lamps:
1. Disposable, nonporous gloves
  2. Disposable whole-body clothing impermeable to PCB's.
  3. Respiratory protection (NIOSH/MSHA approved) against organic vapors and particulates (at least the level of particulate protection required at that stage of work for asbestos protection).
  4. Eye protection
  5. Hard Hats
- G. The Contractor shall provide protective clothing, eye protection, and respiratory protection as required for Inspection Personnel monitoring work activities within the work area.
- H. Personnel Protection and Procedures: The Work Area shall at no time be left unattended after procedures have begun and until all lamps and incidentals have been placed in the properly labeled containers. If immediate transportation to the Owner's temporary storage area is not feasible, the Work Area must be secured in a manner in accordance with Federal, State, and local rules and regulations. All personnel entering the Work Area must don protective clothing and equipment listed herein. Upon exiting the Work Area, all disposable protective clothing shall be placed in approved drums, sealed, and disposed of as specified herein.

- I. Workers with cuts or scratches shall protect these wounds before entering the work area. Similarly, workers who accidentally incur minor cuts or scratches in the course of work activities shall leave the Work Area, cleanse the wound with medical grade soap and seal the wound before returning to the Work Area.
- J. The Contractor shall develop a sequenced plan for the completion of this work and submit this plan in advance of such work to the following Owner's Representative. The plan shall address the following items:
  1. Lists of vehicles, equipment, and personnel to be used in accomplishing the work.
  2. Handling procedures and type of containers to be used.
  3. Safety procedures shall cover all phases of operations including, but not limited to, handling, loading, transporting, disposal, securing loads and first aid procedures.

END OF SECTION 02 85 00



## SECTION 03 30 00 - CAST-IN-PLACE CONCRETE

### PART 1 - GENERAL

#### 1.1 SUMMARY

- A. Section includes cast-in-place concrete, including formwork, reinforcement, concrete materials, mixture design, and placement procedures. Cast-in-place concrete is required for :-
1. Foundations
  2. Concrete fill for concrete masonry walls.
  3. Patching infill where existing slabs are cut for installation of subgrade improvements.

#### 1.2 SUBMITTALS

- A. Product Data: Submit for the following products.
1. Sheet vapor retarder.
  2. Stain pigment. Submit colors for selection.
- B. Design Mix: Submit laboratory test reports for concrete materials and mix design test for each concrete mix proposed to be incorporated into the project. Include product information of admixtures and related items in the proposed mix.

#### 1.3 QUALITY ASSURANCE

- A. ACI Publications: Comply with the following unless modified by requirements in the Contract Documents:
1. ACI 301, "Specifications for Structural Concrete," Sections 1 through 5.
  2. ACI 117, "Specifications for Tolerances for Concrete Construction and Materials."

#### 1.4 DELIVERY, STORAGE, AND HANDLING

- A. Deliver, store, and handle steel reinforcement to prevent bending and damage.

### PART 2 - PRODUCTS

#### 2.1 FORM-FACING MATERIALS

- A. Smooth-Formed Finished Concrete: Form-facing panels that provide continuous, true, and smooth concrete surfaces. Furnish in largest practicable sizes to minimize number of joints.
1. Plywood, metal, or other approved panel materials.
  2. Exterior-grade plywood panels, suitable for concrete forms, complying with DOC PS 1.
- B. Rough-Formed Finished Concrete: Plywood, lumber, metal, or another approved material. Provide lumber dressed on at least two edges and one side for tight fit.

- C. Chamfer Strips: Wood, metal, PVC, or rubber strips, 3/4 by 3/4 inch (19 by 19 mm), minimum.
- D. Form-Release Agent: Commercially formulated form-release agent that does not bond with, stain, or adversely affect concrete surfaces and does not impair subsequent treatments of concrete surfaces.
  - 1. Formulate form-release agent with rust inhibitor for steel form-facing materials.
- E. Form Ties: Factory-fabricated, removable or snap-off glass-fiber-reinforced plastic or metal form ties designed to resist lateral pressure of fresh concrete on forms and to prevent spalling of concrete on removal.

## 2.2 STEEL REINFORCEMENT

- A. Reinforcing Bars: ASTM A 615/A 615M, Grade 60 (Grade 420), deformed.
- B. Plain-Steel Wire: ASTM A 1064/A 1064M.
- C. Plain-Steel Welded-Wire Reinforcement: ASTM A 1064/A 1064M, plain, fabricated from as-drawn steel wire into flat sheets.

## 2.3 REINFORCEMENT ACCESSORIES

- A. Joint Dowel Bars: ASTM A 615/A 615M, Grade 60 (Grade 420), plain-steel bars, cut true to length with ends square and free of burrs.
- B. Bar Supports: Bolsters, chairs, spacers, and other devices for spacing, supporting, and fastening reinforcing bars and welded-wire reinforcement in place. Manufacture bar supports from steel wire, plastic, or precast concrete according to CRSI's "Manual of Standard Practice," of greater compressive strength than concrete and as follows:
  - 1. For concrete surfaces exposed to view, where legs of wire bar supports contact forms, use CRSI Class 1 plastic-protected steel wire or CRSI Class 2 stainless-steel bar supports.
  - 2. For zinc-coated reinforcement, use galvanized wire or dielectric-polymer-coated wire bar supports.

## 2.4 CONCRETE MATERIALS

- A. Cementitious Materials:
  - 1. Portland Cement: ASTM C 150/C 150M, Type I or III.
  - 2. Fly Ash and Slag: Not permitted.
- B. Normal-Weight Aggregates: ASTM C 33/C 33M, Class 1N coarse aggregate or better, graded. Provide aggregates from a single source.
  - 1. Maximum Coarse-Aggregate Size: 1-1/2 inches (38 mm) nominal, unless indicated otherwise.
  - 2. Fine Aggregate: Free of materials with deleterious reactivity to alkali in cement.
- C. Water: ASTM C 94/C 94M and potable.

## 2.5 ADMIXTURES

- A. Air-Entraining Admixture: ASTM C 260/C 260M.
- B. Chemical Admixtures: Certified by manufacturer to be compatible with other admixtures and that do not contribute water-soluble chloride ions exceeding those permitted in hardened concrete. Do not use calcium chloride or admixtures containing calcium chloride.
  - 1. Water-Reducing Admixture: ASTM C 494/C 494M, Type A.
  - 2. Retarding Admixture: ASTM C 494/C 494M, Type B.
  - 3. Water-Reducing and Retarding Admixture: ASTM C 494/C 494M, Type D.
  - 4. High-Range, Water-Reducing Admixture: ASTM C 494/C 494M, Type F.
  - 5. High-Range, Water-Reducing and Retarding Admixture: ASTM C 494/C 494M, Type G.
  - 6. Plasticizing and Retarding Admixture: ASTM C 1017/C 1017M, Type II.

## 2.6 VAPOR RETARDERS

- A. Sheet Vapor Retarder: ASTM E 1745, Class A. Not less than 10 mils (0.25 mm) thick. Include manufacturer's recommended adhesive or pressure-sensitive tape.
  - 1. Products: Subject to compliance with requirements, available products that may be incorporated into the Work include, but are not limited to, the following:
    - a. Carlisle Coatings & Waterproofing, Inc.; Blackline 400.
    - b. Fortifiber Building Systems Group; Moistop Ultra 10.
    - c. Grace Construction Products, W. R. Grace & Co.; Florprufe 120.
    - d. Meadows, W. R., Inc.; Perminator 10 mil.
    - e. Raven Industries Inc.; Vapor Block 10.
    - f. Reef Industries, Inc.; Griffolyn 10 mil Green.
    - g. Stego Industries, LLC; Stego Wrap 10 mil Class A.

## 2.7 CURING MATERIALS

- A. Evaporation Retarder: Waterborne, monomolecular film forming, manufactured for application to fresh concrete.
- B. Absorptive Cover: AASHTO M 182, Class 2, burlap cloth made from jute or kenaf, weighing approximately 9 oz./sq. yd. (305 g/sq. m) when dry.
- C. Moisture-Retaining Cover: ASTM C 171, polyethylene film or white burlap-polyethylene sheet.
- D. Water: Potable.
- E. Curing Compounds: Any one of the following at Contractor's option:-
  - 1. Clear, Waterborne, Membrane-Forming Curing Compound: ASTM C 309, Type 1, Class B, dissipating.
    - a. Products: Subject to compliance with requirements, available products that may be incorporated into the Work include, but are not limited to, the following:
      - 1) BASF Construction Chemicals - Building Systems; Kure 200.
      - 2) Conspec by Dayton Superior; W.B. Resin Cure.

- 3) Dayton Superior Corporation; Day-Chem Rez Cure (J-11-W).
  - 4) Euclid Chemical Company (The), an RPM company; Kurez W VOX; TAMMSCURE WB 30C.
  - 5) L&M Construction Chemicals, Inc.; L&M Cure R.
  - 6) Meadows, W. R., Inc.; 1100-CLEAR.
  - 7) Symons by Dayton Superior; Resi-Chem Clear.
2. Clear, Waterborne, Membrane-Forming Curing Compound: ASTM C 309, Type 1, Class B, nondissipating, certified by curing compound manufacturer to not interfere with bonding of floor covering.
- a. Products: Subject to compliance with requirements, available products that may be incorporated into the Work include, but are not limited to, the following:
    - 1) BASF Construction Chemicals - Building Systems; Kure-N-Seal WB.
    - 2) Conspec by Dayton Superior; Cure and Seal WB.
    - 3) Dayton Superior Corporation; Safe Cure and Seal (J-18).
    - 4) Euclid Chemical Company (The), an RPM company; Aqua Cure VOX; Clearseal WB 150.
    - 5) L&M Construction Chemicals, Inc.; Dress & Seal WB.
    - 6) Meadows, W. R., Inc.; Vocomp-20.
    - 7) Symons by Dayton Superior; Cure & Seal 18 Percent E.
3. Clear, Waterborne, Membrane-Forming Curing Compound: ASTM C 309, Type 1, Class B, 18 to 25 percent solids, nondissipating, certified by curing compound manufacturer to not interfere with bonding of floor covering.
- a. Products: Subject to compliance with requirements, available products that may be incorporated into the Work include, but are not limited to, the following:
    - 1) BASF Construction Chemicals - Building Systems; Kure-N-Seal W.
    - 2) Conspec by Dayton Superior; High Seal.
    - 3) Dayton Superior Corporation; Safe Cure and Seal (J-19).
    - 4) Euclid Chemical Company (The), an RPM company; Diamond Clear VOX; Clearseal WB STD.
    - 5) L&M Construction Chemicals, Inc.; Dress & Seal WB.
    - 6) Meadows, W. R., Inc.; Vocomp-20.
    - 7) Symons by Dayton Superior; Cure & Seal 18 Percent E.
4. Clear, Solvent-Borne, Membrane-Forming Curing and Sealing Compound: ASTM C 1315, Type 1, Class A.
- a. Products: Subject to compliance with requirements, available products that may be incorporated into the Work include, but are not limited to, the following:
    - 1) BASF Construction Chemicals - Building Systems; Kure-N-Seal 25 LV.
    - 2) Conspec by Dayton Superior; Sealcure 1315.
    - 3) Dayton Superior Corporation; Day-Chem Cure and Seal (J-22UV).
    - 4) Euclid Chemical Company (The), an RPM company; Super Diamond Clear; LusterSeal 300.
    - 5) L&M Construction Chemicals, Inc.; Lumiseal Plus.
    - 6) Meadows, W. R., Inc.; CS-309/30.
5. Clear, Waterborne, Membrane-Forming Curing and Sealing Compound: ASTM C 1315, Type 1, Class A.

- a. Products: Subject to compliance with requirements, available products that may be incorporated into the Work include, but are not limited to, the following:
  - 1) BASF Construction Chemicals - Building Systems; Kure 1315.
  - 2) Conspec by Dayton Superior; Sealcure 1315 WB.
  - 3) Euclid Chemical Company (The), an RPM company; Super Diamond Clear VOX; LusterSeal WB 300.
  - 4) L&M Construction Chemicals, Inc.; Lumiseal WB Plus.
  - 5) Meadows, W. R., Inc.; Vocomp-30.
  - 6) Symons by Dayton Superior; Cure & Seal 31 Percent E.

## 2.8 RELATED MATERIALS

- A. Expansion- and Isolation-Joint-Filler Strips: ASTM D 1751, asphalt-saturated cellulosic fiber.
- B. Bonding Agent: ASTM C 1059/C 1059M, Type II, non-redispersible, acrylic emulsion or styrene butadiene.
- C. Epoxy Bonding Adhesive: ASTM C 881, two-component epoxy resin, capable of humid curing and bonding to damp surfaces, of class suitable for application temperature and of grade to suit requirements, and as follows:
  - 1. Types IV and V, load bearing, for bonding hardened or freshly mixed concrete to hardened concrete.
- D. Dovetail Anchor Slots: Hot-dip galvanized-steel sheet, not less than 0.034 inch (0.85 mm) thick, with bent tab anchors. Temporarily fill or cover face opening of slots to prevent intrusion of concrete or debris.

## 2.9 CONCRETE MIXTURES

- A. Prepare design mixtures for each type and strength of concrete, proportioned on the basis of laboratory trial mixture or field test data, or both, according to ACI 301 (ACI 301M).
  - 1. Use a qualified independent testing agency for preparing and reporting proposed mixture designs based on laboratory trial mixtures.
- B. Admixtures: Use admixtures according to manufacturer's written instructions.
  - 1. Use water-reducing, high-range water-reducing or plasticizing admixture in concrete, as required, for placement and workability.
  - 2. Use water-reducing and -retarding admixture when required by high temperatures, low humidity, or other adverse placement conditions.
  - 3. Use water-reducing admixture in pumped concrete, concrete for heavy-use industrial slabs and parking structure slabs, concrete required to be watertight, and concrete with a w/c ratio below 0.50.
- C. Use a qualified independent testing agency for preparing and reporting proposed mix designs for the laboratory trial mix basis.
- D. Design mixes to provide normal weight concrete with the following properties, unless otherwise indicated:-

1. Minimum Compressive Strength: Unless indicated otherwise, provide concrete with 4,000 psi at 28 days.
  2. Maximum Water-Cementitious Materials Ratio: 0.45.
  3. Air Content: 5.5 percent, plus or minus 1.5 percent at point of delivery for 1-1/2-inch (38-mm) nominal maximum aggregate size.
- E. Slump Limits: Unless indicated otherwise, proportion and design mixes to result in concrete slump at point of placement as follows:
1. Reinforced foundation systems: Not less than 3 inches (76 mm) and not more than 5 inches (127 mm).
  2. Concrete containing high-range water-reducing admixture (superplasticizer): Not more than 8 inches (203 mm) after adding admixture to site-verified 2-to-3-inch (51-76 mm) slump concrete.
  3. Other concrete: Not more than 5 inches (127 mm).

## 2.10 FABRICATING REINFORCEMENT

- A. Fabricate steel reinforcement according to CRSI's "Manual of Standard Practice."

## 2.11 CONCRETE MIXING

- A. Ready-Mixed Concrete: Measure, batch, mix, and deliver concrete according to ASTM C 94/C 94M and ASTM C 1116/C 1116M, and furnish batch ticket information.
1. When air temperature is between 85 and 90 deg F (30 and 32 deg C), reduce mixing and delivery time from 1-1/2 hours to 75 minutes; when air temperature is above 90 deg F (32 deg C), reduce mixing and delivery time to 60 minutes.

## PART 3 - EXECUTION

### 3.1 FORMWORK INSTALLATION

- A. Design, erect, shore, brace, and maintain formwork, according to ACI 301 (ACI 301M), to support vertical, lateral, static, and dynamic loads, and construction loads that might be applied, until structure can support such loads.
- B. Construct formwork so concrete members and structures are of size, shape, alignment, elevation, and position indicated, within tolerance limits of ACI 117 (ACI 117M).
- C. Construct forms tight enough to prevent loss of concrete mortar.
- D. Construct forms for easy removal without hammering or prying against concrete surfaces. Provide crush or wrecking plates where stripping may damage cast-concrete surfaces. Provide top forms for inclined surfaces steeper than 1.5 horizontal to 1 vertical.
1. Install keyways, reglets, recesses, and the like, for easy removal.
  2. Do not use rust-stained steel form-facing material.
- E. Set edge forms, bulkheads, and intermediate screed strips for slabs to achieve required elevations and slopes in finished concrete surfaces. Provide and secure units to support screed strips; use strike-off templates or compacting-type screeds.

- F. Provide temporary openings for cleanouts and inspection ports where interior area of formwork is inaccessible. Close openings with panels tightly fitted to forms and securely braced to prevent loss of concrete mortar. Locate temporary openings in forms at inconspicuous locations.
- G. Chamfer exterior corners and edges of permanently exposed concrete.
- H. Form openings, chases, offsets, sinkages, keyways, reglets, blocking, screeds, and bulkheads required in the Work. Determine sizes and locations from trades providing such items.
- I. Clean forms and adjacent surfaces to receive concrete. Remove chips, wood, sawdust, dirt, and other debris just before placing concrete.
- J. Retighten forms and bracing before placing concrete, as required, to prevent mortar leaks and maintain proper alignment.
- K. Coat contact surfaces of forms with form-release agent, according to manufacturer's written instructions, before placing reinforcement.

### 3.2 REMOVING AND REUSING FORMS

- A. General: Formwork for sides of beams, walls, columns, and similar parts of the Work that does not support weight of concrete may be removed after cumulatively curing at not less than 50 deg F (10 deg C) for 24 hours after placing concrete. Concrete has to be hard enough to not be damaged by form-removal operations, and curing and protection operations need to be maintained.
  - 1. Leave formwork for slabs, and other structural elements that support weight of concrete in place until concrete has achieved at least 70 percent of its 28-day design compressive strength.
  - 2. Remove forms only if shores have been arranged to permit removal of forms without loosening or disturbing shores.
- B. Clean and repair surfaces of forms to be reused in the Work. Split, frayed, delaminated, or otherwise damaged form-facing material are not acceptable for exposed surfaces. Apply new form-release agent.
- C. When forms are reused, clean surfaces, remove fins and laitance, and tighten to close joints. Align and secure joints to avoid offsets. Do not use patched forms for exposed concrete surfaces unless approved by Architect.

### 3.3 VAPOR-RETARDER INSTALLATION

- A. Where existing slab is cut for installation of subsurface improvements, maintain continuity between new and existing vapor retarder material.
- B. Place, protect, and repair sheet vapor retarder according to ASTM E 1643 and manufacturer's written instructions.
  - 1. Lap joints 6 inches (150 mm) and seal with manufacturer's recommended tape.

- C. Bituminous Vapor Retarders: Place, protect, and repair bituminous vapor retarder according to manufacturer's written instructions.

### 3.4 STEEL REINFORCEMENT INSTALLATION

- A. General: Comply with CRSI's "Manual of Standard Practice" for fabricating, placing, and supporting reinforcement.
  - 1. Do not cut or puncture vapor retarder. Repair damage and reseal vapor retarder before placing concrete.
- B. Clean reinforcement of loose rust and mill scale, earth, ice, and other foreign materials that reduce bond to concrete.
- C. Accurately position, support, and secure reinforcement against displacement. Locate and support reinforcement with bar supports to maintain minimum concrete cover. Do not tack weld crossing reinforcing bars.
- D. Set wire ties with ends directed into concrete, not toward exposed concrete surfaces.
- E. Install welded-wire reinforcement in longest practicable lengths on bar supports spaced to minimize sagging. Lap edges and ends of adjoining sheets at least one mesh spacing. Offset laps of adjoining sheet widths to prevent continuous laps in either direction. Lace overlaps with wire.

### 3.5 JOINTS

- A. General: Construct joints true to line with faces perpendicular to surface plane of concrete.
  - 1. Provide joints indicated in Drawings. If not indicated, submit proposed joint location plan for approval.
- B. Construction Joints: Install so strength and appearance of concrete are not impaired, at locations indicated or as approved by Architect.
  - 1. Place joints perpendicular to main reinforcement. Continue reinforcement across construction joints unless otherwise indicated. Do not continue reinforcement through sides of strip placements of floors and slabs.
  - 2. Form keyed joints as indicated. Embed keys at least 1-1/2 inches (38 mm) into concrete.
  - 3. Locate joints for slabs in the middle third of spans.
  - 4. Use a bonding agent at locations where fresh concrete is placed against hardened or partially hardened concrete surfaces.
  - 5. Use epoxy-bonding adhesive at locations where fresh concrete is placed against hardened or partially hardened concrete surfaces.
- C. Doweled Joints: Install dowel bars and support assemblies at joints where indicated. Lubricate or asphalt coat one-half of dowel length to prevent concrete bonding to one side of joint.



### 3.6 CONCRETE PLACEMENT

- A. Before placing concrete, verify that installation of formwork, reinforcement, and embedded items is complete and that required inspections are completed.
- B. Before test sampling and placing concrete, water may be added at Project site, subject to limitations of ACI 301 (ACI 301M).
  - 1. Do not add water to concrete after adding high-range water-reducing admixtures to mixture.
- C. Deposit concrete continuously in one layer or in horizontal layers of such thickness that no new concrete is placed on concrete that has hardened enough to cause seams or planes of weakness. If a section cannot be placed continuously, provide construction joints as indicated. Deposit concrete to avoid segregation.
  - 1. Deposit concrete in horizontal layers of depth not to exceed formwork design pressures and in a manner to avoid inclined construction joints.
  - 2. Consolidate placed concrete with mechanical vibrating equipment according to ACI 301 (ACI 301M).
  - 3. Do not use vibrators to transport concrete inside forms. Insert and withdraw vibrators vertically at uniformly spaced locations to rapidly penetrate placed layer and at least 6 inches (150 mm) into preceding layer. Do not insert vibrators into lower layers of concrete that have begun to lose plasticity. At each insertion, limit duration of vibration to time necessary to consolidate concrete and complete embedment of reinforcement and other embedded items without causing mixture constituents to segregate.
- D. Deposit and consolidate concrete for floors and slabs in a continuous operation, within limits of construction joints, until placement of a panel or section is complete.
  - 1. Consolidate concrete during placement operations, so concrete is thoroughly worked around reinforcement and other embedded items and into corners.
  - 2. Maintain reinforcement in position on chairs during concrete placement.
  - 3. Screed slab surfaces with a straightedge and strike off to correct elevations.
  - 4. Slope surfaces uniformly to drains where required.
  - 5. Begin initial floating using bull floats or darbies to form a uniform and open-textured surface plane, before excess bleedwater appears on the surface. Do not further disturb slab surfaces before starting finishing operations.
- E. Dusting surface(s) of concrete to remove water or for any other purpose is not acceptable.
- F. Cold-Weather Placement: Comply with ACI 306.1 and as follows. Protect concrete work from physical damage or reduced strength that could be caused by frost, freezing actions, or low temperatures.
- G. Hot-Weather Placement: Place concrete according to recommendations in ACI 305R.

### 3.7 FINISHING FORMED SURFACES

- A. Rough-Formed Finish: As-cast concrete texture imparted by form-facing material with tie holes and defects repaired and patched. Remove fins and other projections that exceed specified limits on formed-surface irregularities.

1. This is for concrete surfaces not exposed to public view.
- B. Smooth-Formed Finish: As-cast concrete texture imparted by form-facing material, arranged in an orderly and symmetrical manner with a minimum of seams. Repair and patch tie holes and defects. Remove fins and other projections that exceed specified limits on formed-surface irregularities.
  1. This is for concrete surfaces exposed to public view, to receive a rubbed finish, or to be covered with a coating or covering material applied directly to concrete.
- C. Rubbed Finish: Apply the following to smooth-formed-finished as-cast concrete where indicated:
  1. Grout-Cleaned Finish: Wet concrete surfaces and apply grout of a consistency of thick paint to coat surfaces and fill small holes. Mix 1 part portland cement to 1-1/2 parts fine sand with a 1:1 mixture of bonding admixture and water. Add white portland cement in amounts determined by trial patches, so color of dry grout matches adjacent surfaces. Scrub grout into voids and remove excess grout. When grout whitens, rub surface with clean burlap and keep surface damp by fog spray for at least 36 hours.
- D. Related Unformed Surfaces: At tops of walls, horizontal offsets, and similar unformed surfaces adjacent to formed surfaces, strike off smooth and finish with a texture matching adjacent formed surfaces. Continue final surface treatment of formed surfaces uniformly across adjacent unformed surfaces unless otherwise indicated.

### 3.8 FINISHING FLOORS AND SLABS

- A. General: Comply with ACI 302.1R recommendations for screeding, re-straightening, and finishing operations for concrete surfaces. Do not wet concrete surfaces.
- B. Trowel Finish: After applying float finish, apply first troweling and consolidate concrete by hand or power-driven trowel. Continue troweling passes and re-straighten until surface is free of trowel marks and uniform in texture and appearance. Grind smooth any surface defects that would telegraph through applied coatings or floor coverings.
  1. Apply a trowel finish to surfaces indicated, exposed to view or to be covered with resilient flooring, carpet, ceramic tile set over a cleavage membrane, paint, or another thin-film-finish coating system.
  2. Finish and measure surface, so gap at any point between concrete surface and an unlevelled, freestanding, 10-ft.- (3.05-m-) long straightedge resting on two high spots and placed anywhere on the surface does not exceed 1/8 inch (3.2 mm).
- C. Trowel and Fine-Broom Finish: Apply a first trowel finish to surfaces where ceramic tile is to be installed by either thickset or thinset method. While concrete is still plastic, slightly scarify surface with a fine broom.
  1. Comply with flatness and levelness tolerances for trowel-finished floor surfaces.
- D. Broom Finish: Apply broom finish to exterior concrete platforms, steps, ramps, and elsewhere as indicated.
  1. Immediately after float finishing, slightly roughen trafficked surface by brooming with fiber-bristle broom perpendicular to main traffic route.

### 3.9 MISCELLANEOUS CONCRETE ITEM INSTALLATION

- A. Filling In: Fill in holes and openings left in concrete structures after work of other trades is in place unless otherwise indicated. Mix, place, and cure concrete, as specified, to blend with in-place construction. Provide other miscellaneous concrete filling indicated or required to complete the Work.

### 3.10 CONCRETE PROTECTING AND CURING

- A. General: Protect freshly placed concrete from premature drying and excessive cold or hot temperatures. Comply with ACI 306.1 for cold-weather protection and ACI 301 (ACI 301M) for hot-weather protection during curing.
- B. Evaporation Retarder: Apply evaporation retarder to unformed concrete surfaces if hot, dry, or windy conditions cause moisture loss approaching 0.2 lb/sq. ft. x h (1 kg/sq. m x h) before and during finishing operations. Apply according to manufacturer's written instructions after placing, screeding, and bull floating or darbying concrete, but before float finishing.
- C. Formed Surfaces: Cure formed concrete surfaces, including underside of beams, supported slabs, and other similar surfaces. If forms remain during curing period, moist cure after loosening forms. If removing forms before end of curing period, continue curing for remainder of curing period.
- D. Unformed Surfaces: Begin curing immediately after finishing concrete. Cure unformed surfaces, including floors and slabs, concrete floor toppings, and other surfaces.
- E. Cure concrete according to ACI 308.1, by one or a combination of the following methods:
  - 1. Moisture Curing: Keep surfaces continuously moist for not less than seven days with the following materials:
    - a. Water.
    - b. Continuous water-fog spray.
    - c. Absorptive cover, water saturated, and kept continuously wet. Cover concrete surfaces and edges with 12-inch (300-mm) lap over adjacent absorptive covers.
  - 2. Moisture-Retaining-Cover Curing: Cover concrete surfaces with moisture-retaining cover for curing concrete, placed in widest practicable width, with sides and ends lapped at least 12 inches (300 mm), and sealed by waterproof tape or adhesive. Cure for not less than seven days. Immediately repair any holes or tears during curing period, using cover material and waterproof tape.
    - a. Moisture cure or use moisture-retaining covers to cure concrete surfaces to receive floor coverings.
    - b. Moisture cure or use moisture-retaining covers to cure concrete surfaces to receive penetrating liquid floor treatments.
    - c. Cure concrete surfaces to receive floor coverings with either a moisture-retaining cover or a curing compound that the manufacturer certifies does not interfere with bonding of floor covering used on Project.
  - 3. Curing Compound: Apply uniformly in continuous operation by power spray or roller according to manufacturer's written instructions. Recoat areas subjected to

heavy rainfall within three hours after initial application. Maintain continuity of coating and repair damage during curing period.

- a. Removal: After curing period has elapsed, remove curing compound without damaging concrete surfaces by method recommended by curing compound manufacturer unless manufacturer certifies curing compound does not interfere with bonding of floor covering used on Project.
4. Curing and Sealing Compound: Apply uniformly to floors and slabs indicated in a continuous operation by power spray or roller according to manufacturer's written instructions. Recoat areas subjected to heavy rainfall within three hours after initial application. Repeat process 24 hours later and apply a second coat. Maintain continuity of coating and repair damage during curing period.

### 3.11 CONCRETE SURFACE REPAIRS

- A. Defective Concrete: Repair and patch defective areas when approved by Architect. Remove and replace concrete that cannot be repaired and patched to Architect's approval.
- B. Patching Mortar: Mix dry-pack patching mortar, consisting of 1 part portland cement to 2-1/2 parts fine aggregate passing a No. 16 (1.18-mm) sieve, using only enough water for handling and placing.
- C. Repairing Formed Surfaces: Surface defects include color and texture irregularities, cracks, spalls, air bubbles, honeycombs, rock pockets, fins and other projections on the surface, and stains and other discolorations that cannot be removed by cleaning.
  1. Immediately after form removal, cut out honeycombs, rock pockets, and voids more than 1/2 inch (13 mm) in any dimension to solid concrete. Limit cut depth to 3/4 inch (19 mm). Make edges of cuts perpendicular to concrete surface. Clean, dampen with water, and brush-coat holes and voids with bonding agent. Fill and compact with patching mortar before bonding agent has dried. Fill form-tie voids with patching mortar or cone plugs secured in place with bonding agent.
  2. Repair defects on surfaces exposed to view by blending white portland cement and standard portland cement so that, when dry, patching mortar matches surrounding color. Patch a test area at inconspicuous locations to verify mixture and color match before proceeding with patching. Compact mortar in place and strike off slightly higher than surrounding surface.
  3. Repair defects on concealed formed surfaces that affect concrete's durability and structural performance as determined by Architect.
- D. Repairing Unformed Surfaces: Test unformed surfaces, such as floors and slabs, for finish and verify surface tolerances specified for each surface. Correct low and high areas. Test surfaces sloped to drain for trueness of slope and smoothness; use a sloped template.
  1. Repair finished surfaces containing defects. Surface defects include spalls, popouts, honeycombs, rock pockets, crazing and cracks in excess of 0.01 inch (0.25 mm) wide or that penetrate to reinforcement or completely through unreinforced sections regardless of width, and other objectionable conditions.
  2. After concrete has cured at least 14 days, correct high areas by grinding.
  3. Correct localized low areas during or immediately after completing surface finishing operations by cutting out low areas and replacing with patching mortar. Finish repaired areas to blend into adjacent concrete.

4. Correct other low areas scheduled to receive floor coverings with a repair underlayment. Prepare, mix, and apply repair underlayment and primer according to manufacturer's written instructions to produce a smooth, uniform, plane, and level surface. Feather edges to match adjacent floor elevations.
5. Correct other low areas scheduled to remain exposed with a repair topping. Cut out low areas to ensure a minimum repair topping depth of 1/4 inch (6 mm) to match adjacent floor elevations. Prepare, mix, and apply repair topping and primer according to manufacturer's written instructions to produce a smooth, uniform, plane, and level surface.
6. Repair defective areas, except random cracks and single holes 1 inch (25 mm) or less in diameter, by cutting out and replacing with fresh concrete. Remove defective areas with clean, square cuts and expose steel reinforcement with at least a 3/4-inch (19-mm) clearance all around. Dampen concrete surfaces in contact with patching concrete and apply bonding agent. Mix patching concrete of same materials and mixture as original concrete, except without coarse aggregate. Place, compact, and finish to blend with adjacent finished concrete. Cure in same manner as adjacent concrete.
7. Repair random cracks and single holes 1 inch (25 mm) or less in diameter with patching mortar. Groove top of cracks and cut out holes to sound concrete and clean off dust, dirt, and loose particles. Dampen cleaned concrete surfaces and apply bonding agent. Place patching mortar before bonding agent has dried. Compact patching mortar and finish to match adjacent concrete. Keep patched area continuously moist for at least 72 hours.

### 3.12 FIELD QUALITY CONTROL

- A. Coordinate with testing and inspecting agency to perform field tests and inspections. Owner shall engage and pay for testing and inspection agency services.
- B. Inspections:
  1. Steel reinforcement placement.
  2. Verification of use of required design mixture.
  3. Concrete placement, including conveying and depositing.
  4. Curing procedures and maintenance of curing temperature.
  5. Verification of concrete strength before removal of shores and forms from beams and slabs.
- C. Concrete Tests: Testing of composite samples of fresh concrete obtained according to ASTM C 172/C 172M shall be performed according to the following requirements:
  1. Testing Frequency: Obtain one composite sample for each day's pour of each concrete mixture exceeding 5 cu. yd. (4 cu. m), but less than 25 cu. yd. (19 cu. m), plus one set for each additional 50 cu. yd. (38 cu. m) or fraction thereof.
    - a. When frequency of testing provides fewer than five compressive-strength tests for each concrete mixture, testing shall be conducted from at least five randomly selected batches or from each batch if fewer than five are used.
  2. Slump: ASTM C 143/C 143M; one test at point of placement for each composite sample, but not less than one test for each day's pour of each concrete mixture. Perform additional tests when concrete consistency appears to change.

3. Air Content: ASTM C 231/C 231M, pressure method, for normal-weight concrete; one test for each composite sample, but not less than one test for each day's pour of each concrete mixture.
4. Concrete Temperature: ASTM C 1064/C 1064M; one test hourly when air temperature is 40 deg F (4.4 deg C) and below or 80 deg F (27 deg C) and above, and one test for each composite sample.
5. Compression Test Specimens: ASTM C 31/C 31M.
  - a. Cast and laboratory cure two sets of two standard cylinder specimens for each composite sample.
6. Compressive-Strength Tests: ASTM C 39/C 39M; test one set of two laboratory-cured specimens at 7 days and one set of two specimens at 28 days.
  - a. Test one set of two field-cured specimens at 7 days and one set of two specimens at 28 days.
  - b. A compressive-strength test shall be the average compressive strength from a set of two specimens obtained from same composite sample and tested at age indicated.
7. Strength of each concrete mixture will be satisfactory if every average of any three consecutive compressive-strength tests equals or exceeds specified compressive strength and no compressive-strength test value falls below specified compressive strength by more than 500 psi (3.4 MPa).
8. Test results shall be reported in writing to Architect, concrete manufacturer, and Contractor within 48 hours of testing. Reports of compressive-strength tests shall contain Project identification name and number, date of concrete placement, name of concrete testing and inspecting agency, location of concrete batch in Work, design compressive strength at 28 days, concrete mixture proportions and materials, compressive breaking strength, and type of break for both 7- and 28-day tests.
9. Nondestructive Testing: Impact hammer, sonoscope, or other nondestructive device may be permitted by Architect but will not be used as sole basis for approval or rejection of concrete.
10. Additional Tests: Testing and inspecting agency shall make additional tests of concrete when test results indicate that slump, air entrainment, compressive strengths, or other requirements have not been met, as directed by Architect. Testing and inspecting agency may conduct tests to determine adequacy of concrete by cored cylinders complying with ASTM C 42/C 42M or by other methods as directed by Architect.
11. Additional testing and inspecting, at Contractor's expense, will be performed to determine compliance of replaced or additional work with specified requirements.
12. Correct deficiencies in the Work that test reports and inspections indicate do not comply with the Contract Documents.

END OF SECTION 033000

## SECTION 04 27 00 - UNIT MASONRY ASSEMBLIES

### PART 1 - GENERAL

#### 1.1 SUMMARY

- A. This Section includes unit masonry assemblies consisting of the following:
  1. Concrete Masonry Units (CMU)
  2. Mortar and grout.
  3. Masonry joint reinforcement.
  4. Anchors.
  5. Miscellaneous masonry accessories.

#### 1.2 QUALITY ASSURANCE

- A. Source Limitations for Mortar Materials: Obtain mortar ingredients of a uniform quality, including color for exposed masonry, from one manufacturer for each cementitious component and from one source or producer for each aggregate.

#### 1.3 DELIVERY, STORAGE, AND HANDLING

- A. Store masonry units on elevated platforms in a dry location. If units are not stored in an enclosed location, cover tops and sides of stacks with waterproof sheeting, securely tied. If units become wet, do not install until they are dry.
- B. Store cementitious materials on elevated platforms, under cover, and in a dry location. Do not use cementitious materials that have become damp.
- C. Store aggregates where grading and other required characteristics can be maintained, and contamination avoided.
- D. Store masonry accessories, including metal items, to prevent corrosion and accumulation of dirt and oil.

### PART 2 - PRODUCTS

#### 2.1 CONCRETE MASONRY UNITS (CMU)

- A. Concrete Masonry Units: ASTM C 90.
  1. Unit Compressive Strength: Minimum average net-area compressive strength of 1900 psi (13.1 MPa).
  2. Types and Sizes: Match existing unit masonry sizes.
    - a. Standard Units: Manufacturer's standard units with nominal face dimensions of 16-inches (406 mm) long x 8-inches (203 mm) high x 8-inches (203 mm) thick, unless indicated otherwise.
  3. Exposed Faces: Manufacturer's standard color and texture.

#### 2.2 MORTAR AND GROUT MATERIALS

- A. Portland Cement: ASTM C 150, Type I or II, except Type III may be used for cold-weather construction. Provide natural color or white cement as required to produce mortar color indicated.
- B. Hydrated Lime: ASTM C 207, Type S.
- C. Portland Cement-Lime Mix: Packaged blend of portland cement complying with ASTM C 150, Type I or Type III, and hydrated lime complying with ASTM C 207.
- D. Mortar Cement: ASTM C 1329.
- E. Masonry Cement: ASTM C 91.
- F. Aggregate for Mortar: ASTM C 144; except for joints less than 1/4 inch (6.5 mm) thick, use aggregate graded with 100 percent passing the No. 16 (1.18-mm) sieve.
- G. Aggregate for Grout: ASTM C 404.
- H. Water: Potable.
- I. Products: Subject to compliance with requirements, provide one of the following:
  - 1. Mortar Cement:
    - a. Magnolia Superbond Mortar Cement; Blue Circle Cement.
    - b. Lafarge Mortar Cement; Lafarge Corporation.
    - c. Lone Star Industries
    - d. Holnam, Inc.

## 2.3 MASONRY JOINT REINFORCEMENT AND TIES

- A. General: ASTM A 951.
- B. Joint Anchor. Slip-Set Joint Anchor by Hohmann & Barnard (DA 2200 by Dur-O-Wall), or approved equivalent. Fasten one leg to wall. Extend other leg into intersecting wall and embed in grout by grout filling cell of abutting masonry unit.

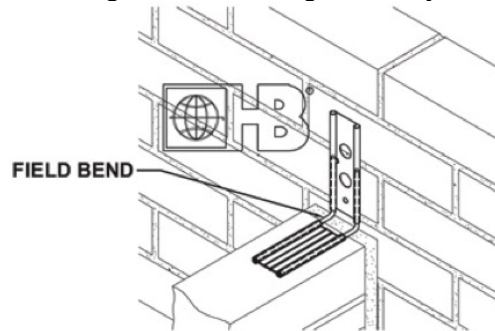

## 2.5 CMU MORTAR AND GROUT MIXES

- A. General: Do not use admixtures, including pigments, air-entraining agents, accelerators, retarders, water-repellent agents, antifreeze compounds, or other admixtures, unless otherwise indicated.
  - 1. Do not use calcium chloride in mortar or grout.



- B. Mortar for Unit Masonry: ASTM C270, Proportion Specification, for Type 'S' mortar.
  - 1. Color for CMU: Natural mortar color.
- C. Pre-blended, Dry Mortar Mix: Furnish dry mortar ingredients in the form of a pre-blended mix. Measure quantities by weight to ensure accurate proportions, and thoroughly blend ingredients before delivering to Project site.
- D. Mortar for Unit Masonry: Comply with ASTM C 270, Proportion Specification, Type S.

## PART 3 - EXECUTION

### 3.1 EXAMINATION

- A. Examine conditions for compliance with requirements for installation tolerances and other conditions affecting performance.
  - 1. Make corrections to unsatisfactory conditions.

### 3.2 INSTALLATION

- A. Thickness: Construct with units to match existing.
- B. Do not wet concrete masonry units.
- C. Cutting: Cut masonry units with motor-driven saws to provide clean, sharp, unchipped edges. Cut units as required to provide a continuous pattern and to fit adjoining construction. Where possible, use full-size units without cutting. Install cut units with cut surfaces and, where possible, cut edges concealed.
  - 1. CMU: Cut masonry units dry.
- D. Cleaning Reinforcing: Before placing, remove loose rust, ice and other coatings from reinforcing.
- E. Hollow Metal Door Frames: Fill hollow metal frames in masonry walls with grout as wall is laid. Rake back 1/2-inch joint between hollow metal frame and adjacent masonry unit to receive sealant.

### 3.3 CONSTRUCTION TOLERANCES

- A. Comply with tolerances in ACI 530.1/ASCE 6/TMS 602 and the following:
- B. For conspicuous vertical lines, such as external corners, door jambs, reveals, and expansion and control joints, do not vary from plumb by more than 1/4 inch in 20 feet (6 mm in 6 m), nor 1/2 inch (12 mm) maximum.
- C. For vertical alignment of exposed head joints, do not vary from plumb by more than 1/4 inch in 10 feet (6 mm in 3 m), nor 1/2 inch (12 mm) maximum.
- D. For conspicuous horizontal lines, such as exposed lintels, sills, parapets, and reveals, do not vary from level by more than 1/4 inch in 20 feet (6 mm in 6 m), nor 1/2 inch (12 mm) maximum.

1. For exposed bed joints, do not vary from thickness indicated by more than plus or minus 1/8 inch (3 mm), with a maximum thickness limited to 1/2 inch (12 mm). Do not vary from bed-joint thickness of adjacent courses by more than 1/8 inch (3 mm).
2. For exposed head joints, do not vary from thickness indicated by more than plus or minus 1/8 inch (3 mm). Do not vary from adjacent bed-joint and head-joint thicknesses by more than 1/8 inch (3 mm).

### 3.4 LAYING MASONRY WALLS

- A. Lay out walls in advance for accurate spacing of surface bond patterns with uniform joint thicknesses and for accurate location of openings, movement-type joints, returns, and offsets.
  1. Avoid using less-than-half-size units, particularly at corners, jambs, and, where possible, at other locations.
- B. Bond Pattern for Exposed Masonry: Do not use units with less than nominal 4-inch (100-mm) horizontal face dimensions at corners or jambs.
  1. Match existing bond pattern.
- C. Fill space between hollow-metal frames and masonry solidly with mortar.

### 3.5 MORTAR BEDDING AND JOINTING

- A. CMU: Lay hollow CMU as follows:
  1. With full mortar coverage on horizontal and vertical face shells.
  2. Provide Joint Anchors 16-inches centers for connecting new masonry to existing masonry.
- B. Tool exposed joints slightly concave when thumbprint hard, using a jointer larger than the joint thickness, unless otherwise indicated.

### 3.6 REPAIRING, POINTING, AND CLEANING

- A. Remove and replace masonry units that are loose, chipped, broken, stained, or otherwise damaged or that do not match adjoining units. Install new units to match adjoining units; install in fresh mortar, pointed to eliminate evidence of replacement.
  1. Patch units with excessive spalls or chips.
- B. Pointing: During the tooling of joints, enlarge voids and holes, except weep holes, and completely fill with mortar. Point up joints, including corners, openings, and adjacent construction, to provide neat, uniform appearances. Prepare joints for sealant application.
- C. In-Progress Cleaning: Clean unit masonry as work progresses by dry brushing to remove mortar fins and smears before tooling joints.
- D. Final Cleaning: After mortar is thoroughly set and cured, clean exposed masonry.
  1. Remove large mortar particles by hand with wooden paddles and nonmetallic scrape hoes or chisels.
  2. Clean concrete masonry by cleaning method indicated in NCMA TEK 8-2 applicable to type of stain on exposed surfaces.

3.7 MASONRY WASTE DISPOSAL

- A. Excess Masonry Waste: Remove excess, masonry waste and legally dispose off Owner's property.

END OF SECTION 04 27 00

## SECTION 06 10 00 - ROUGH CARPENTRY

### PART 1 - GENERAL

#### 1.1 SUMMARY

- A. This Section includes:
  - 1. Wood blocking and nailers.

#### 1.2 DELIVERY, STORAGE, AND HANDLING

- A. Stack lumber, place spacers between each bundle to provide air circulation. Provide for air circulation around stacks and under coverings.

### PART 2 - PRODUCTS

#### 2.1 WOOD PRODUCTS, GENERAL

- A. Lumber: DOC PS 20 and applicable rules of lumber grading agencies certified by the American Lumber Standards Committee Board of Review.
  - 1. Factory mark each piece of lumber with grade stamp of grading agency.
  - 2. Where nominal sizes are indicated, provide actual sizes required by DOC PS 20 for moisture content specified. Where actual sizes are indicated, they are minimum dressed sizes for dry lumber.
  - 3. Provide dressed lumber, S4S, unless otherwise indicated.
  - 4. Provide dry lumber with 19 percent maximum moisture content at time of dressing for 2-inch nominal (38-mm actual) thickness or less, unless otherwise indicated.

#### 2.2 WOOD-PRESERVATIVE-TREATED MATERIALS

- A. Preservative Treatment by Pressure Process: AWWA U1; Use Categories as follows:
  - 1. Category UC2 for interior construction and in contact with masonry and concrete, not in contact with the ground,
- B. Kiln-dry material after treatment to a maximum moisture content of 19 percent for lumber and 15 percent for plywood. Do not use material that is warped or does not comply with requirements for untreated material.
- C. Mark each treated item with the treatment quality mark of an inspection agency approved by the American Lumber Standards Committee Board of Review.
- D. Application: Treat items indicated on Drawings, and the following:
  - 1. Wood blocking, furring, stripping, and similar concealed members in contact with masonry or concrete.

#### 2.3 DIMENSION LUMBER

- A. General: Provide dimension lumber of grades indicated according to the American Lumber Standards Committee National Grading Rule provisions of the grading agency indicated.

- B. Nailers, Furring and Blocking: "Standard" stud grade, or No. 3 grade lumber with 19 percent maximum moisture content of any species or board-size lumber as required.

## 2.4 FASTENERS

- A. General: Provide fasteners of size and type indicated that comply with requirements specified in this Article for material and manufacture.
  - 1. Where rough carpentry is exposed to weather, in ground contact, in concrete and masonry, or in area of high relative humidity, provide fasteners with hot-dip zinc coating complying with ASTM A 153/A 153M, or Type 304 stainless steel.
  - 2. Provide Type 300 or 400 stainless steel fasteners applied alkaline copper quaternary (ACQ) treated wood and other wood treatments of a similar nature. Hot-dip galvanized, corrosion-coated steel, steel, copper, aluminum, and other metal fasteners are not acceptable for such applications.
- B. Nails, Brads, and Staples: ASTM F 1667.
- C. Power-Driven Fasteners: CABO NER-272.
- D. Wood Screws: ASME B18.6.1.
- E. Lag Bolts: ASME B18.2.1. (ASME B18.2.3.8M).
- F. Bolts: Steel bolts complying with ASTM A 307, Grade A (ASTM F 568M, Property Class 4.6); with ASTM A 563 (ASTM A 563M) hex nuts and, where indicated, flat washers.
- G. Expansion Anchors: Anchor bolt and sleeve assembly of material indicated below with capability to sustain, without failure, a load equal to 6 times the load imposed when installed in unit masonry assemblies and equal to 4 times the load imposed when installed in concrete as determined by testing per ASTM E 488 conducted by a qualified independent testing and inspecting agency.
  - 1. Material: Carbon-steel components, zinc plated to comply with ASTM B 633, Class Fe/Zn 5.
  - 2. Material: Stainless steel with bolts and nuts complying with ASTM F 593 and ASTM F 594, Alloy Group 1 or 2 (ASTM F 738M and ASTM F 836M, Grade A1 or A4).

## PART 3 - EXECUTION

### 3.1 INSTALLATION, GENERAL

- A. Set rough carpentry to required levels and lines, with members plumb, true to line, cut, and fitted. Fit rough carpentry to other construction; scribe and cope as needed for accurate fit. Locate furring, nailers, blocking, and similar supports to comply with requirements for attaching other construction.
- B. Nail in accordance with Recommended Nailing Schedule in NFPA Manual for House Framing. Where detailed nailing requirements are not specified, nail size and spacing shall be sufficient to develop adequate strength for connection without splitting the members.

- C. For rough carpentry related to roofing work, fasten and secure nailers, blocking and cants in accordance with applicable requirements of Factory Mutual 1-49 Perimeter Flashing, unless more stringent requirements are indicated.
- D. Do not use materials with defects that impair quality of rough carpentry or pieces that are too small to use with minimum number of joints or optimum joint arrangement.
- E. Apply field treatment complying with AWPA M4 to cut surfaces of preservative-treated lumber and plywood. Or, brush coat field cut treated wood members with copper naphthenate solution or pressure treatment manufacturer's recommended product.
- F. Securely attach rough carpentry work to substrate by anchoring and fastening as indicated, complying with the following:
  - 1. NES NER-272 for power-driven fasteners.
  - 2. Table 2304.9.1, "Fastening Schedule," in ICC's International Building Code.
  - 3. Table 23-II-B-1, "Nailing Schedule," and Table 23-II-B-2, "Wood Structural Panel Roof Sheathing Nailing Schedule," in ICBO's Uniform Building Code.
- G. Use common wire nails, unless otherwise indicated. Select fasteners of size that will not fully penetrate members where opposite side will be exposed to view or will receive finish materials. Make tight connections between members. Install fasteners without splitting wood; predrill as required.

### 3.2 WOOD BLOCKING, AND NAILER INSTALLATION

- A. Install where indicated and where required for attaching other work. Form to shapes indicated and cut as required for true line and level of attached work. Coordinate locations with other work involved.
- B. Attach items to substrates to support applied loading. Recess bolts and nuts flush with surfaces, unless otherwise indicated. Build anchor bolts into masonry during installation of masonry work. Where possible, secure anchor bolts to formwork before concrete placement.

END OF SECTION 06 10 00

## SECTION 07 90 00 - JOINT SEALANTS

### PART 1 - GENERAL

#### 1.1 SUMMARY

- A. This section describes sealants and sealant accessories. -

#### 1.2 QUALITY ASSURANCE

- A. Source Limitations: Obtain each type of joint sealant through one source from a single manufacturer.

#### 1.3 PROJECT CONDITIONS

- A. Environmental Limitations: Do not proceed with installation of joint sealants under the following conditions:
  - 1. When ambient and substrate temperature conditions are outside limits permitted by joint sealant manufacturer.
  - 2. When joint substrates are wet.
- B. Joint-Width Conditions: Do not proceed with installation of joint sealants where joint widths are less than those allowed by joint sealant manufacturer.
- C. Joint-Substrate Conditions: Do not proceed with installation of joint sealants until contaminants capable of interfering with adhesion are removed from joint substrates.

### PART 2 - PRODUCTS

#### 2.1 BUILDING JOINTS

- A. Building Joint Sealant Schedule: Apply types of sealants at the following locations
  - 1. Acrylic Latex Sealant:
    - a. Interior concrete block and gypsum board wall joints where paint is finish is required.
  - 2. Single Component Urethane Sealant:
    - a. Metal-to-metal joints
    - b. Joints at openings not requiring paint
    - c. All other joints and indications not listed herein.
  - 3. Single Component Silicone Sealant:
    - a. Ceramic tile wall joints and pipe penetrations.
  - 4. Mastic Sealant: Under thresholds.
- B. Acrylic Latex Sealant: Single component, non-staining, non-bleeding, non-sagging; acrylic latex or siliconized acrylic latex, ASTM C 834, Type OP, Grade NF; color to match adjacent surfaces. Subject to compliance to specified requirements, provide products by one of the following, or approved equal:
  - 1. MasterSeal NP520 (Sonolac) by BASF Master Builders (Sonneborn) .
  - 2. ChemCalk 900 by Bostik.

3. AC-20 by Pecora.
- C. Single Component Urethane: Non-sag gun grade; ASTM C920, Type S, Grade NS, Class 25; use N, T, M and A; color to match adjacent surfaces. Subject to compliance to specified requirements, provide products by one of the following, or approved equal:
  1. MasterSeal (Sonolastic) NP1 by BASF Master Builders (Sonneborn).
  2. ChemCalk 600 by Bostik.
  3. Dynatrol 1 by Pecoral .
- D. Single Component Silicone: Non-sag gun grade; ASTM C920, Type S, Grade NT, Class 25; use M, G, A and O; color to match adjacent surfaces. Subject to compliance to specified requirements, provide products by one of the following, or approved equal:
  1. 786; Dow Corning.
  2. 898; Pecora Corporation.
- E. Mastic Sealant: One component butyl rubber sealant. Subject to compliance to specified requirements, provide products by or approved equal:
  1. Multi-Purpose Sealant by BASF Master Builders (Sonneborn).
  2. Chemcalk 300.
  3. BC-158 by Pecora.

## 2.2 MATERIALS, GENERAL

- A. Compatibility: Provide joint sealants, backings, and related materials that are compatible with one another and with joint substrates under conditions of service and application, as demonstrated by sealant manufacturer based on testing and field experience.
- B. Colors of Exposed Joint Sealants: Match color of adjacent material.

## 2.3 JOINT-SEALANT BACKING

- A. General: Non-staining, compatible with joint substrates, sealants, primers, and other joint fillers; and are approved for applications indicated by sealant manufacturer based on field experience and laboratory testing.
- B. Cylindrical Sealant Backings: ASTM C 1330, of types indicated below and of size and density to control sealant depth and otherwise contribute to producing optimum sealant performance:
  1. Type C: Closed-cell material with a surface skin.
  2. Type O: Open-cell material.
  3. Type B: Bicellular material with a surface skin.
  4. Type: Any material indicated above.
- C. Bond-Breaker Tape: Polyethylene tape or other plastic tape recommended by sealant manufacturer for preventing sealant from adhering to rigid, inflexible joint-filler materials or joint surfaces at back of joint where such adhesion would result in sealant failure. Provide self-adhesive tape where applicable.

## 2.4 MISCELLANEOUS MATERIALS



- A. Primer: Material recommended by joint sealant manufacturer where required for adhesion of sealant to joint substrates indicated, as determined from preconstruction joint-sealant-substrate tests and field tests.
- B. Cleaners for Nonporous Surfaces: Chemical cleaners acceptable to manufacturers of sealants and sealant backing materials, free of oily residues or other substances capable of staining or harming joint substrates and adjacent nonporous surfaces in any way, and formulated to promote optimum adhesion of sealants with joint substrates.
- C. Masking Tape: Non-staining, nonabsorbent material compatible with joint sealants and surfaces adjacent to joints.

## PART 3 - EXECUTION

### 3.1 EXISTING JOINTS AND SEALANTS

- A. Rake and remove existing sealants, including backer-rods and accessories completely, from joints to be re-sealed, reglets at wall joints where sheet metal is replaced.
- B. Clean, repair and rework joint surfaces in order to satisfactorily receive new sealants and related joint accessory materials such as backer rods and primers.

### 3.2 EXAMINATION

- A. Examine joints indicated to receive joint sealants, with Installer present, for compliance with requirements for joint configuration, installation tolerances, and other conditions affecting joint-sealant performance.
- B. Make corrections to unsatisfactory conditions.

### 3.3 PREPARATION

- A. Surface Cleaning of Joints: Clean joints immediately before installing joint sealants to comply with manufacturer's written instructions and the following requirements:
  - 1. Remove all foreign material from joint substrates that could interfere with adhesion of joint sealant, including dust, paints (except for permanent, protective coatings tested and approved for sealant adhesion and compatibility by sealant manufacturer), old joint sealants, oil, grease, waterproofing, water repellents, water, surface dirt, and frost.
  - 2. Clean porous (masonry and concrete) joint substrate surfaces by brushing, grinding, blast cleaning, mechanical abrading, or a combination of these methods to produce a clean, sound substrate capable of developing optimum bond with joint sealants. Remove loose particles remaining from above cleaning operations by vacuuming or blowing out joints with oil-free compressed air.
  - 3. Remove laitance and form-release agents from concrete.
  - 4. Clean nonporous surfaces with chemical cleaners or other means that do not stain, harm substrates, or leave residues capable of interfering with adhesion of sealants.
- B. Joint Priming: Prime joint substrates where recommended by joint sealant manufacturer, based on preconstruction joint-sealant-substrate tests or prior experience. Apply primer

to comply with joint sealant manufacturer's written instructions. Confine primers to areas of joint-sealant bond; do not allow spillage or migration onto adjoining surfaces.

- C. Masking Tape: Use masking tape where required to prevent contact of sealant with adjoining surfaces that otherwise would be permanently stained or damaged by such contact or by cleaning methods required to remove sealant smears. Remove tape immediately after tooling without disturbing joint seal.

### 3.4 INSTALLATION OF JOINT SEALANTS

- A. General: Comply with joint sealant manufacturer's written installation instructions for products and applications indicated, unless more stringent requirements apply.
- B. Sealant Installation Standard: Comply with ASTM C 1193 for use of joint sealants as applicable to materials, applications, and conditions indicated.
- C. Install sealant backings to support sealants during application and at position required to produce cross-sectional shapes and depths of installed sealants relative to joint widths that allow optimum sealant movement capability.
  - 1. Do not leave gaps between ends of sealant backings.
  - 2. Do not stretch, twist, puncture, or tear sealant backings.
  - 3. Remove absorbent sealant backings that have become wet before sealant application and replace them with dry materials.
- D. Install bond-breaker tape behind sealants where sealant backings are not used between sealants and back of joints.
- E. Install sealants by proven techniques to comply with the following and at the same time backings are installed:
  - 1. Place sealants so they directly contact and fully wet joint substrates.
  - 2. Completely fill recesses provided for each joint configuration.
  - 3. Produce uniform, cross-sectional shapes and depths relative to joint widths that allow optimum sealant movement capability.
- F. Tooling of Non-sag Sealants: Immediately after sealant application and before skinning or curing begins, tool sealants according to requirements specified below to form smooth, uniform beads of configuration indicated; to eliminate air pockets; and to ensure contact and adhesion of sealant with sides of joint.
  - 1. Remove excess sealants from surfaces adjacent to joint.
  - 2. Use tooling agents that are approved in writing by sealant manufacturer and that do not discolor sealants or adjacent surfaces.
  - 3. Provide concave joint configuration per Figure 5A in ASTM C 1193, unless otherwise indicated.

### 3.5 CLEANING

- A. Clean and remove excess sealants or sealant smears adjacent to joints as the Work progresses by methods and with cleaning materials approved in writing by manufacturers of joint sealants and of products in which joints occur.

### 3.6 PROTECTION

- A. Protect joint sealants during and after curing period from contact with contaminating substances and from damage resulting from construction operations or other causes so sealants are without deterioration or damage at time of Substantial Completion.

END OF SECTION 07 90 00

## SECTION 08 11 13 - STEEL DOOR FRAMES

### PART 1 - GENERAL

#### 1.1 SUMMARY

- A. This Section includes steel doors and frames.
  - 1. Modifications to existing steel frames are included.
  - 3. Interior steel frames, for wood doors.
- B. Related Sections
  - 1. Division 8 Section "Door Hardware" for door hardware.
  - 2. Division 9 Section "Painting" for field painting factory-primed door frames.

#### 1.2 SUBMITTALS

- A. Product Data: For door frame indicated, include designation, type, level and model, material description, core description, construction details, and finishes.

Shop Drawings: Show the following:

- 1. Elevations of each door and panel design.
  - 2. Details of doors including vertical and horizontal edge details.
  - 3. Frame details for each frame type including dimensioned profiles.
  - 4. Details and locations of reinforcement and preparations for hardware.
  - 5. Details of each different wall opening condition.
  - 6. Details of anchorages, accessories, joints, and connections.
  - 7. Coordination of glazing frames and stops with glass and glazing requirements.
- B. Schedule: Submit schedule of units using same reference numbers for details and openings as those on drawings.

#### 1.3 QUALITY ASSURANCE

- A. Door Hardware Institute: DHI - "The Installation of Commercial Steel Doors and Steel Frames, Insulated Steel Doors in Wood Frames and Builder's Hardware."
- B. Steel Door and Frame Standard: Comply with ANSI A 250.8, unless more stringent requirements are indicated.
- C. Fire-Rated Door Assemblies: Assemblies complying with NFPA 80 that are listed and labeled by a testing and inspecting agency acceptable to authorities having jurisdiction, for fire-protection ratings indicated, based on testing according to NFPA 252.

#### 1.4 DELIVERY, STORAGE, AND HANDLING

- A. Deliver doors and frames cardboard-wrapped or crated to provide protection during transit and job storage. Provide additional protection to prevent damage to finish of factory-finished doors and frames.
- B. Inspect doors and frames on delivery for damage and notify shipper and supplier if damage is found. Minor damages may be repaired provided refinished items match new

work and are acceptable to Architect. Remove and replace damaged items that cannot be repaired as directed.

- C. Store doors and frames at building site under cover. Place units on minimum 4-inch- (100-mm-) high wood blocking. Avoid using non-vented plastic or canvas shelters that could create a humidity chamber. If door packaging becomes wet, remove cartons immediately. Provide minimum 1/4-inch (6-mm) spaces between stacked doors to permit air circulation.

## PART 2 - PRODUCTS

### 2.1 MANUFACTURERS

- A. Subject to compliance with requirements, provide products by one of the following:
  - 1. Amweld Building Products, Inc.
  - 2. Benchmark Commercial Doors; a division of General Products Co., Inc.
  - 3. Ceco Door Products; a United Dominion Company.
  - 4. Curries Company.
  - 5. Republic Builders Products.
  - 6. Steelcraft; a division of Ingersoll-Rand.

### 2.2 MATERIALS

- A. Hot-Rolled Steel Sheets: ASTM A 569/A 569M, Commercial Steel (CS), Type B; free of scale, pitting, or surface defects; pickled and oiled.
- B. Cold-Rolled Steel Sheets: ASTM A 366/A 366M, Commercial Steel (CS), or ASTM A 620/A 620M, Drawing Steel (DS), Type B; stretcher-leveled standard of flatness.
- C. Metallic-Coated Steel Sheets: ASTM A 653/A 653M, Commercial Steel (CS), Type B, with an A40 (ZF120) zinc-iron-alloy (galvannealed) coating; stretcher-leveled standard of flatness.

### 2.3 FRAMES

- A. General: Provide steel frames for doors that comply with ANSI A250.8 and with details indicated for type and profile. Conceal fastenings, unless otherwise indicated.
- B. Frames of 0.053-inch (16 gage) - (1.3-mm-) thick steel sheet.
  - 1. Door Silencers: ~~Except on weather-stripped frames,~~ Fabricate stops to receive three silencers on strike jambs of single-door frames and two silencers on heads of double-door frames.
- C. Supports and Anchors: Fabricated from not less than 0.042-inch- (1.0-mm-) thick, electrolytic zinc-coated or metallic-coated steel sheet.
- D. Inserts, Bolts, and Fasteners: Manufacturer's standard units. Where zinc-coated items are to be built into exterior walls, comply with ASTM A 153/A 153M, Class C or D as applicable.

## 2.4 FRAME ANCHORS

- A. Jamb Anchors:
  - 1. Masonry Type: Adjustable strap-and-stirrup or T-shaped anchors to suit frame size, not less than 0.042 inch (1.0 mm) thick, with corrugated or perforated straps not less than 2 inches (50 mm) wide by 10 inches (250 mm) long; or wire anchors not less than 0.177 inch (4.5 mm) thick.
  - 2. Stud-Wall Type: Designed to engage stud, welded to back of frames; not less than 0.042 inch (1.0 mm) thick.
- B. Floor Anchors: Formed from same material as frames, not less than 0.042 inch (1.0 mm) thick, and as follows:
  - 1. Monolithic Concrete Slabs: Clip-type anchors, with two holes to receive fasteners.

## 2.5 FABRICATION

- A. General: Fabricate units to comply with ANSI A250.8 and to be rigid, neat in appearance, and free from defects including warp and buckle. Where practical, fit and assemble units in manufacturer's plant. Clearly identify work that cannot be permanently factory assembled before shipment, to assure proper assembly at Project site.
- B. Construction: Because these units are located in a wet condition, i.e. restroom, fabricate units from metallic-coated steel sheet.
- C. Tolerances: Comply with SDI 117, "Manufacturing Tolerances for Standard Steel Doors and Frames."
- D. Frame Construction: Fabricate frames to shape shown.
  - 1. Fabricate frames with mitered or coped and continuously welded corners.
  - 2. Door Silencers: Drill stops to receive door silencers as follows. Keep holes clear during construction.
    - a. Double-Door Frames: Drill stop in head jamb to receive two door silencers.
- E. Reinforce doors and frames to receive surface-applied hardware. Drilling and tapping for surface-applied hardware may be done at Project site.
- F. Locate hardware as indicated on Shop Drawings or, if not indicated, according to ANSI A250.8.
- G. Fabricate concealed stiffeners, reinforcement, edge channels, louvers, and moldings from either cold- or hot-rolled steel sheet.
- H. Exposed Fasteners: Unless otherwise indicated, provide countersunk flat or oval heads for exposed screws and bolts.
- I. Hardware Preparation: Prepare doors and frames to receive mortised and concealed hardware according to final door hardware schedule and templates provided by hardware supplier. Comply with applicable requirements in ANSI A250.6 and ANSI A115 Series specifications for door and frame preparation for hardware.
  - 1. Locate hardware as indicated, or if not indicated, according to mounted door hardware.

## 2.6 FINISHES

- A. Prime Finish: Manufacturer's standard, factory-applied coat of rust-inhibiting primer complying with ANSI A250.10 for acceptance criteria.

## PART 3 - EXECUTION

### 3.1 INSPECTION

- A. Examine openings and conditions where hollow metal units are to be installed.
- B. Make corrections to unsatisfactory conditions.

### 3.2 EXISTING FRAMES

- A. Modify, including adding reinforcement to existing frames to receive hardware.
  - 1. Single-Door Frames: Drill stop in strike jamb to receive three door silencers.
- B. Repair and patch existing frame, where damaged and to remove surface defects.

### 3.3 PREPARATION

- A. Remove welded-in shipping spreaders installed at factory. Restore exposed finish by grinding, filling, and dressing, as required to make repaired area smooth, flush, and invisible on exposed faces.
- B. Prior to installation, adjust and securely brace welded hollow metal frames for squareness, alignment, twist, and plumbness to the following tolerances:
  - 1. Squareness: Plus or minus 1/16 inch (1.6 mm), measured at door rabbet on a line 90 degrees from jamb perpendicular to frame head.
  - 2. Alignment: Plus or minus 1/16 inch (1.6 mm), measured at jambs on a horizontal line parallel to plane of wall.
  - 3. Twist: Plus or minus 1/16 inch (1.6 mm), measured at opposite face corners of jambs on parallel lines, and perpendicular to plane of wall.
  - 4. Plumbness: Plus or minus 1/16 inch (1.6 mm), measured at jambs on a perpendicular line from head to floor.
- C. Drill and tap to receive non-templated, mortised, and surface-mounted door hardware.

### 3.4 INSTALLATION

- A. General: Install according to Shop Drawings, manufacturer's data, and as specified.
- B. Placing Frames: Comply with provisions in SDI 105, unless otherwise indicated. Set frames accurately in position, plumbed, aligned, and braced securely until permanent anchors are set. After wall construction is completed, remove temporary braces and spreaders, leaving surfaces smooth and undamaged.
  - 1. Except for frames located in constructed walls or partitions, place frames before construction of enclosing walls and ceilings.

2. In masonry construction, provide at least 3 wall anchors per jamb; install adjacent to hinge location on hinge jamb and at corresponding heights on strike jamb. Acceptable anchors include masonry wire anchors and masonry T-shaped anchors.
  - a. Fully grout frames in masonry and concrete walls.

### 3.5 ADJUSTING AND CLEANING

- A. Final Adjustments: Check and readjust operating hardware items immediately before final inspection. Leave work in complete and proper operating condition. Remove and replace defective work, including hollow metal work that is warped, bowed, or otherwise unacceptable.
- B. Prime-Coat Touchup: Immediately after installation, sand smooth any rusted or damaged areas of prime coat and apply touch up of compatible air-drying primer.
- C. Protection Removal: Immediately before final inspection, remove protective wrappings from doors and frames.

END OF SECTION 08 11 13



## SECTION 08 14 16 - FLUSH WOOD DOORS

### PART 1 - GENERAL

#### 1.1 SUMMARY

- A. This Section includes the following:
  - 1. Solid-core doors with wood-veneer faces.
- B. Related Sections
  - 1. Division 8 Section "Steel Door Frames"
  - 2. Division 8 Section "Door Hardware"
  - 3. Division 9 Section "Painting" for field staining wood doors.

#### 1.2 SUBMITTALS

- A. Product Data: For each type of door. Include details of core and edge construction, louvers, and trim for openings. Include factory-finishing specifications.
- B. Shop Drawings: Indicate location, size, and hand of each door; elevation of each kind of door; construction details not covered in Product Data; location and extent of hardware blocking; and other pertinent data.
- C. Samples for Verification Selection: Submit manufacturer's actual finished wood samples for verification of match.

#### 1.3 QUALITY ASSURANCE

- A. Source Limitations: Obtain flush wood doors through one source from a single manufacturer.
- B. Quality Standard: Comply with NWWDA I.S.1-A, "Architectural Wood Flush Doors."

#### 1.4 DELIVERY, STORAGE, AND HANDLING

- A. Protect doors during transit, storage, and handling to prevent damage, soiling, and deterioration. Comply with requirements of referenced standard and manufacturer's written instructions.
  - 1. Individually package doors in plastic bags or cardboard cartons.
  - 2. Protect doors with resilient packaging, sealed with heat shrink plastic.
  - 3. Do not store in damp or wet areas, or in areas where sunlight may bleach veneer. Seal top and bottom edges. Break seals on-site to permit ventilation.
- B. Comply with requirements of referenced standard and manufacturer's written instructions.
- C. Package doors individually in plastic bags or cardboard cartons, if doors are factory-finished; or cardboard cartons and wrap bundles of doors in plastic sheeting for field finished doors.
- D. Mark each door on top and bottom rail with opening number used on Shop Drawings.

## 1.5 COORDINATION

- A. For shop preparation for hardware, obtain hardware templates. Coordinate locations of hardware and provide adequate reinforcement to receive hardware items for proper operation of doors.

## 1.6 WARRANTY

- A. Special Warranty: Manufacturer's standard form, signed by manufacturer, Installer, and Contractor, in which manufacturer agrees to repair or replace doors that are defective in materials or workmanship, have warped (bow, cup, or twist) more than 1/4 inch (6.4 mm) in a 42-by-84-inch (1067-by-2134-mm) section, or show telegraphing of core construction in face veneers exceeding 0.01 inch in a 3-inch (0.25 mm in a 75-mm) span.
  - 1. Warranty shall be in effect during the following period of time from date of Substantial Completion:
    - a. Solid-Core Interior Doors: Life of installation.

## PART 2 - PRODUCTS

### 2.1 MANUFACTURERS

- A. Manufacturers: Subject to compliance with requirements, provide products by one of the following:
  - 1. Flush Wood Doors:
    - a. Algoma Hardwoods Inc.
    - b. Buell Door Company.
    - c. Chappell Door Co.
    - d. Eggers Industries; Architectural Door Division.
    - e. Ideal Wood Products, Inc.
    - f. IPIK Door Company.
    - g. Marlite.
    - h. Marshfield
    - i. Mohawk Flush Doors, Inc.
    - j. Oshkosh Architectural Door Co.
    - k. Southwood Door Co.
    - l. VT Industries Inc.
    - m. Weyerhaeuser Company.

### 2.2 SOLID-CORE DOORS

- A. Interior Veneer-Faced Doors for Transparent Finish:
  - 1. Grade: Premium, with Grade A faces.
  - 2. Species and Cut: Red Oak, plain or quarter sliced.
  - 3. Core: Either glued or non-glued block or structural composite lumber.
  - 4. Construction: Five or seven plies with stiles and rails bonded to core, then entire unit abrasive planed before veneering.
- B. Fabricate doors with "wet-use" adhesives. Factory treat with manufacturer's water repellent to comply with NWWDA I.S. 4.

## 2.3 FABRICATION

- A. Fabricate doors in sizes indicated for Project-site fitting.
  - 1. For pre-finished doors, factory fit doors to suit frame-opening sizes indicated, with the following uniform clearances and bevels, unless otherwise indicated:
    - a. Comply with clearance requirements of referenced quality standard for fitting.
- B. Factory machine doors for hardware that is not surface applied. Locate hardware to comply with DHI-WDHS-3. Comply with final hardware schedules, door frame Shop Drawings, DHI A115-W series standards, and hardware templates.
  - 1. Coordinate measurements of hardware mortises in metal frames to verify dimensions and alignment before factory machining.

## 2.4 FACTORY FINISHING

- A. General: Comply with referenced quality standard for factory finishing.
- B. Transparent Finish:
  - 1. Finish: NWWDA I.S.1-A System TR-6 catalyzed polyurethane.
  - 2. Color: As indicated in Drawings.
  - 3. Staining: Match existing wood doors in this building.
  - 4. Sheen: Satin.

## PART 3 - EXECUTION

### 3.1 EXAMINATION

- A. Examine doors and installed door frames before hanging doors.
  - 1. Verify that frames comply with indicated requirements for type, size, location, and swing characteristics and have been installed with level heads and plumb jambs.
  - 2. Reject doors with defects.
- B. Make corrections to unsatisfactory conditions.

### 3.2 INSTALLATION

- A. Hardware: For installation, see Division 8 Section "Door Hardware."
- B. Condition doors to average prevailing humidity in installation area prior to hanging.
- C. Manufacturer's Written Instructions: Install doors to comply with manufacturer's written instructions, referenced quality standard, and as indicated.
- D. Factory-Fitted Doors: Align in frames for uniform clearance at each edge.
- E. Factory-Finished Doors: Restore finish before installation if fitting or machining is required at Project site.

### 3.3 ADJUSTING

- A. Operation: Rehang or replace doors that do not swing or operate freely.
- B. Finished Doors: Replace doors that are damaged or do not comply with requirements. Doors may be repaired or refinished if work complies with requirements and shows no evidence of repair or refinishing.

END OF SECTION 08 14 16

## SECTION 08 71 00 - DOOR HARDWARE

### PART 1 - GENERAL

#### 1.1 SUMMARY

- A. This Section includes commercial door hardware for swinging doors.
- B. Related Sections:
  - 1. Division 8 Section, Metal Door Frames .
  - 2. Division 8 Section, Flush Wood Doors.

#### 1.2 SUBMITTALS

- A. Product Data: Submit manufacturers' catalog cut sheets and technical information for each item of hardware. Include information showing compliance with requirements.
- B. Hardware Schedule: Organize hardware schedule into "hardware sets" indicating complete designations of every item required for each door or opening. Include each item, quantities, manufacturers' catalog numbers, sizes and hardware identifications corresponding to ANSI type or function number to manufacturer's catalog number. Hardware schedule sets and door numbers of submittal shall correspond with respective numbers assigned for this project.
  - 1. Keying: Include keying schedule after keying conference described below.

#### 1.3 QUALITY ASSURANCE

- A. Hardware Supplier and Installer Qualifications: An employer of workers trained and approved by lock manufacturer.
- B. Source Limitations: Obtain each type and variety of door hardware from a single manufacturer, unless otherwise indicated.
- C. Keying Conference: Conduct conference at Project site. In addition to Owner, Contractor, and Architect, conference participants shall also include Installer's Architectural Hardware Consultant.

#### 1.4 DELIVERY, STORAGE, AND HANDLING

- A. Tag each item or package separately with identification related to the final door hardware sets, and include basic installation instructions, templates, and necessary fasteners with each item or package.
- B. Deliver keys to Owner.

#### 1.5 COORDINATION

- A. Templates: Distribute door hardware templates for doors, frames, and other work specified to be factory prepared for installing door hardware. Check Shop Drawings of other work to confirm that adequate provisions are made for locating and installing door hardware to comply with indicated requirements.

## PART 2 - PRODUCTS

### 2.1 SCHEDULED DOOR HARDWARE

- A. Hardware Sets are indicated in "Hardware Schedule" at the end of this Section.
- B. Material requirements for design, grade, function, finish, size, and other distinctive qualities of each type of finish hardware are indicated below.

### 2.2 GENERAL ACCESSIBILITY REQUIREMENT

- A. Accessibility Requirements: Where handles, pulls, latches, locks, and other operating devices are indicated to comply with accessibility requirements, comply with the U.S. Architectural & Transportation Barriers Compliance Board's "Americans with Disabilities Act (ADA), Accessibility Guidelines for Buildings and Facilities (ADAAG)."
  - 1. Comply with the following maximum opening-force requirements: Interior, Non-Fire-Rated Hinged Doors: 5 lbf (22.2 N) applied perpendicular to door.

### 2.3 HINGES

- A. Hinges: ANSI A156.1.
  - 1. Interior Doors: Non-rising pins.
  - 2. Tips: Flat button and matching plug, finished to match leaves.
  - 3. Doors with Closers: Ball bearing type.
  - 4. Full mortise, heavy duty, 5-knuckle type.
- B. Size and Gage:
  - 1. 0.134 gage metal minimum.
  - 2. 4-1/2" x 4-1/2" (114 x 114 mm).
- C. Template Requirements: Except for hinges and pivots to be installed entirely (both leaves) into wood doors and frames, provide only template-produced units.
- D. Fasteners - Screws: Phillips flat-head; machine screws (drilled and tapped holes) for metal doors, wood screws for wood doors. Finish screw heads to match surface of hinges.
- E. Manufacturers: Subject to compliance with project requirements, provide products manufactured by the following, or approved equal:
  - 1. T2714 by McKinney.
  - 2. FBB 179 by Stanley.
  - 3. BB 1279 by Hager.
  - 4. BB 21 by PBB

### 2.4 MORTISE LOCKSETS

- A. Locksets: Heavy-duty mortise lockset with escutcheon plate trim. ANSI A156.13, Series 1000, Grade 1. Stamped steel case with steel or brass parts
  - 1. Mortise Locks: Minimum 3/4-inch (19-mm) latchbolt throw.
  - 2. Deadbolts: Minimum 1-inch (25-mm) bolt throw.

3. Lockset Manufacturers and Products:
  - a. 8800 series by Yale.
  - b. L1000 series by Schlage
  - c. 8200 by Sargent
  - d. 40H by Best.
- B. Strikes: Manufacturer's standard wrought box strike for each latch or lock bolt, with curved lip extended to protect frame, finished to match hardware set.
  1. Strikes for Mortise Locks and Latches: BHMA A156.13.
- C. Lock Trim: ANSI A156.2. Finish to match lockset.
  1. Levers: Cast metal or forged.



2. Design: Straight blade lever. handles with elongated escutcheon trim plate. One of the following manufacturers and products, or approved equal:
  - a. Jefferson JNSL by Yale.
  - b. Lever Design 07 by Schlage.
  - c. Lever Design B by Sargent.
  - d. Lever Design 16 by Best.
3. Fronts for mortise locks and latches: Standard bevel, armored fronts on mortise locks.

## 2.5 MORTISE DEADBOLTS

- A. Mortise type.
  1. Key outside, paddle operation to open inside. ADA-compliant.
    - a. Key cylinders capable of receiving Owner's proprietary interchangeable key cores.
  2. Minimum 1-inch latch bolt throw
  3. Manufacturers and Products: Basis of Design product, L series by Schlage, or equivalent product by Sargent, Best, or Yale.

## 2.6 KEYING AND KEYCORES

- A. Key Cores: Key to Owner's "Best" 7-pin system, which is a standard for this campus. Removable and interchangeable construction key cores from Best.
  1. Interchangeable Cores: Provide interchangeable key core inserts, removable by use of a special key; usable with other manufacturers' cylinders.
  2. Order final cores at the time submittals are made. Install final permanent cores immediately after Owner's acceptance.

- B. Keying: Coordinate with Owner for keying.
  - 1. Set keying to existing master and grandmaster key for this building, and campus as designated by Owner.
- C. Keys: Nickel silver.
  - 1. Tag and identify keys.
  - 2. Turn over to the Owner as directed.
  - 3. Number of Keys: 4

## 2.7 PUSH-PULLS

- A. ANSI A156.6. Manufacturer's standard exposed fasteners for installation. Through-bolted for matched pairs, but not for single units.
  - 1. Plates: 0.050-inch thick with 6" x 16" stainless steel plates.
  - 2. Products: 8200 pull and 8302-6 pull plate units by Ives; 1001-9 and 1001-9 with 3B pull by Trimco; or approved equal.

## 2.8 CLOSERS

- A. Grade 1, PT1, C02000 series, surface mounted modern type conforming to ANSI A156.4.
  - 1. Regular arms for overhead closers, except as otherwise indicated.
  - 2. Coordinate closer arms and closer locations with door swing and walls to avoid damage to adjacent construction.
- B. Products: Series 4000 by LCN, 7700 series by Norton, EN351 series by Sargent, 400 series by Yale, or approved equal.

## 2.9 KICKPLATES

- A. General: ANSI A156.6. Stainless steel, 18 gage (1.27 mm) thick material unless indicated otherwise, protection plates. Width not more than 1-1/2 inches (38 mm) on stop side smaller than the door width x the height indicated.
- B. Kickplates: J102, 12 inches high.

## 2.10 STOPS

- A. Door Stops: ANSI A156.16. Metal base with rubber stops. Provide floor stops unless indicated otherwise in the Hardware Schedule.
  - 1. Wall mounted type, L02111, round metal retainer with convex resilient bumper. No fasteners visible on installed assembly. Manufacturer's recommended fasteners for substrates provided.
    - a. 407 by Ives; 1276CCS by Trimco; or approved equal.

## 2.11 MISCELLANEOUS DEVICES

- A. Mutes/Silencers: ANSI A156.16. L03011. Rubber type, 3 for single door openings. Color - grey.
  - 1. Products: GJ64 by Glynn Johnson, 1229A by Trimco, 608 by Rockwood, or approved equal.



## 2.12 FABRICATION

- A. Base Metals: Produce door hardware units of base metal, using manufacturer's standard metal alloy, composition, temper, and hardness. Furnish metals of a quality equal to or greater than that of specified door hardware units and BHMA A156.18. Do not furnish manufacturer's standard materials or forming methods if different from specified standard.
- B. Fasteners: Provide door hardware manufactured to comply with published templates generally prepared for machine, wood, and sheet metal screws. Provide screws according to commercially recognized industry standards for application intended, except aluminum fasteners are not permitted. Provide Phillips flat-head screws with finished heads to match surface of door hardware, unless otherwise indicated.

## 2.13 FINISHES

- A. Standard: BHMA A156.18, as indicated in door hardware sets.
- B. Finish: Match finish of existing hardware in this building - Oli rubbed bronze.

## PART 3 - EXECUTION

### 3.1 EXAMINATION

- A. Examine doors and frames, with Installer present, for compliance with requirements for installation tolerances, wall and floor construction, and other conditions affecting performance.
- B. Make corrections to unsatisfactory conditions.

### 3.2 PREPARATION

- A. Hollow Metal: Comply with DHI A115 Series.
  - 1. Surface-Applied Door Hardware: Drill and tap doors and frames according to ANSI A250.6.
- B. Wood Doors: Comply with DHI A115-W Series.

### 3.3 INSTALLATION

- A. Mounting Heights: Mount door hardware units at heights as required to comply with governing regulations.
  - 1. Standard Steel Doors and Frames: DHI's "Recommended Locations for Architectural Hardware for Standard Steel Doors and Frames."
  - 2. Wood Doors: DHI WDHS.3, "Recommended Locations for Architectural Hardware for Wood Flush Doors."
- B. Install each door hardware item to comply with manufacturer's written instructions. Where cutting and fitting are required to install door hardware onto or into surfaces that are later to be painted or finished in another way, coordinate removal, storage, and reinstallation of

surface protective trim units with finishing work specified in Division 9 Sections. Do not install surface-mounted items until finishes have been completed on substrates involved.

1. Set units level, plumb, and true to line and location. Adjust and reinforce attachment substrates as necessary for proper installation and operation.
2. Drill and countersink units that are not factory prepared for anchorage fasteners. Space fasteners and anchors according to industry standards.

C. Drill and countersink units that are not factory prepared for anchorage fasteners. Space fasteners and anchors in accordance with industry standards.

1. Install with fasteners provided with hardware units, or provide fastener type recommended by manufacturer. Do not use unauthorized fasteners, such as TEK fasteners for closers.

D. Closers: Provide through-bolts to fasten portion of closer at door leaf. Include reinforcing plate.

E. Doorstops: Locate floor type doorstops close to wall to avoid traffic. Coordinate mounting location of wall bumpers with door lockset trim.

### 3.4 ADJUSTING

A. Adjust and check each operating item of door hardware and each door to ensure proper operation or function of every unit. Replace units that cannot be adjusted to operate as intended. Adjust door control devices to compensate for final operation of heating and ventilating equipment and to comply with referenced accessibility requirements.

1. Door Closers: Unless otherwise required by authorities having jurisdiction, adjust sweep period so that, from an open position of 70 degrees, the door will take at least 3 seconds to move to a point 3 inches (75 mm) from the latch, measured to the leading edge of the door.

### 3.5 CLEANING AND PROTECTION

A. Clean adjacent surfaces soiled by door hardware installation. Clean operating items as necessary to restore proper function and finish.

B. Provide final protection and maintain conditions that ensure that door hardware is without damage or deterioration at time of Substantial Completion.

### 3.6 HARDWARE SCHEDULE – GENERAL

A. General: Develop, submit and provide hardware sets for each type of door use indicated in the door schedule in the drawings for door categories listed below.

1. Where hardware sets are not designated, provide hardware set similar to door serving similar function in the building.
2. Include hardware items where not indicated in hardware sets, but are obviously required for door assembly to work properly as intended.

### 3.7 HARDWARE SCHEDULE – INTERIOR DOORS

B. Hardware Set No. I-1:

1. Single interior wood doors with hollow metal frames.

2. Toilet Rooms

- 1-1/2 pairs ..... hinges
- 1 set ..... push-pulls
- 1 each ..... mortise deadbolt
- 1 each ..... closer
- 1 each ..... kickplate
- 3 each ..... mutes
- 1 each ..... wall stop
- 1 each ..... marble threshold (Re: Division 9 Section, Ceramic Tile)

C. Hardware Set No. I-2:

- 1. Single interior wood doors with hollow metal frames.
- 2. Stage
  - 1-1/2 pairs ..... hinges
  - 1 each ..... lockset, F04
  - 1 each ..... kickplate
  - 3 each ..... mutes
  - 1 each ..... door stop

END OF SECTION 08 71 00

## SECTION 09 21 16 - DRYWALL ASSEMBLIES

### PART 1 - GENERAL

#### 1.1 SUMMARY

- A. This Section includes the following:
  - 1. Interior gypsum wallboard.
  - 2. Non-load-bearing steel framing.
  - 3. Sound attenuating insulation.

#### 1.2 DELIVERY, STORAGE, AND HANDLING

- A. Store materials inside under cover and keep them dry and protected against damage from weather, direct sunlight, surface contamination, corrosion, construction traffic, and other causes. Stack gypsum panels flat.

### PART 2 - PRODUCTS

#### 2.1 MANUFACTURERS

- A. Manufacturers: Subject to compliance with requirements, provide products by one of the following:
  - 1. Steel Framing and Furring:
    - a. Clark-Dietrich
    - b. Steel Structural Products, LLC
    - c. Super Stud Building Products, Inc.
  - 2. Panel Board and Related Products:
    - a. American Gypsum Co.
    - b. G-P Gypsum Corp.
    - c. National Gypsum Company.
    - d. United States Gypsum Co.

#### 2.2 STEEL PARTITION FRAMING

- A. General: Comply with ASTM C 754 for conditions indicated.
  - 1. Steel Sheet Components: Comply with ASTM C 645 requirements for metal and with ASTM A 653/A 653M, G60 (Z180), hot-dip galvanized zinc coating.
- B. Steel Studs and Runners: ASTM C 645.
  - 1. Minimum Base Metal Thickness; Interior partitions: 0.0312 inch (20 gage), unless indicated otherwise.
  - 2. Depth; 6-inches and 3-5/8 inches.
- C. Cold-Rolled Channel Bridging: 0.0538-inch (1.37-mm) bare steel thickness, with minimum 1/2-inch- (12.7-mm-) wide flange.
  - 1. Depth: 1-1/2 inches (38.1 mm).
  - 2. Clip Angle: 1-1/2 by 1-1/2 inch (38.1 by 38.1 mm), 0.068-inch- (1.73-mm-) thick, galvanized steel.

- D. Fasteners for Metal Framing: Type, material, size, corrosion resistance, holding power, and other properties required to fasten steel members to substrates.

### 2.3 INTERIOR GYPSUM WALLBOARD

- A. Panel Size: Provide in maximum lengths and widths available that will minimize joints in each area and correspond with support system indicated.
- B. Water-Resistant Gypsum Backing Board: ASTM C 630/C 630M.
  - 1. Core: 5/8 inch (15.9 mm), Type X.
  - 2. Locations: Walls and partitions to receive ceramic tile.

### 2.4 TRIM ACCESSORIES

- A. Interior Trim: ASTM C 1047.
  - 1. Material: Galvanized or aluminum-coated steel sheet.
  - 2. Shapes:
    - a. Cornerbead: Use at outside corners.
    - b. LC-Bead (J-Bead): Use at exposed panel edges.

### 2.5 JOINT TREATMENT MATERIALS

- A. General: Comply with ASTM C 475.
- B. Joint Tape - Interior Gypsum Wallboard: Paper.
- C. Joint Compound for Interior Gypsum Wallboard: For each coat use formulation that is compatible with other compounds applied on previous or for successive coats.
  - 1. Pre-filling: At open joints and damaged surface areas, use setting-type taping compound.
  - 2. Embedding and First Coat: For embedding tape and first coat on joints, fasteners, and trim flanges, use drying-type, all-purpose compound.
    - a. Use setting-type compound for installing paper-faced metal trim accessories.
  - 3. Fill Coat: For second coat, use drying-type, all-purpose compound.
  - 4. Finish Coat: For third coat, use drying-type, all-purpose compound.
- D. Joint Compound for Tile Backing Panels:
  - 1. Water-Resistant Gypsum Backing Board: Use setting-type taping and setting-type, sandable topping compounds.

### 2.6 AUXILIARY MATERIALS

- A. General: Provide auxiliary materials that comply with referenced installation standards and manufacturer's written recommendations.
- B. Steel Drill Screws: ASTM C 1002, unless otherwise indicated.
  - 1. Use screws complying with ASTM C 954 for fastening panels to steel members from 0.033 to 0.112 inch (0.84 to 2.84 mm) thick.

- C. Sound Attenuation Blankets: ASTM C 665, Type I (blankets without membrane facing) produced by combining thermosetting resins with mineral fibers manufactured from glass, slag wool, or rock wool.
  - 1. 3 inches (76 mm) thick, unless indicated otherwise.
  - 2. Subject to compliance with requirements, provide products by one of the following, or approved equal -
    - a. Georgia-Pacific Corp.; Sound Control Blanket.
    - b. Gold Bond Building Products Div., National Gypsum Co.; Glass Fiber Noise Barrier Batt.
    - c. United States Gypsum Co.; Thermafiber SAFB.

## PART 3 - EXECUTION

### 3.1 EXAMINATION

- A. Examine areas and substrates for compliance with requirements and conditions affecting performance.
- B. Make corrections to unsatisfactory conditions.

### 3.2 INSTALLING STEEL FRAMING, GENERAL

- A. Installation Standards: ASTM C 754, and ASTM C 840 requirements that apply to framing installation.
- B. Install supplementary framing, blocking, and bracing at terminations in gypsum board assemblies to support fixtures, equipment services, heavy trim, grab bars, toilet accessories, furnishings, or similar construction. Comply with details indicated and with gypsum board manufacturer's written recommendations or, if none available, with United States Gypsum's "Gypsum Construction Handbook."
- C. Isolate steel framing from building structure at locations indicated to prevent transfer of loading imposed by structural movement.
  - 1. Isolate ceiling assemblies where they abut or are penetrated by building structure.
  - 2. Isolate partition framing and wall furring where it abuts structure, except at floor. Install slip-type joints at head of assemblies that avoid axial loading of assembly and laterally support assembly.
- D. Do not bridge building control and expansion joints with steel framing or furring members. Frame both sides of joints independently.

### 3.3 INSTALLING STEEL PARTITION

- A. Install tracks (runners) at floors, ceilings, where gypsum board assemblies abut other construction.
- B. Installation Tolerance: Install each steel framing and furring member so fastening surfaces vary not more than 1/8 inch (3 mm) from the plane formed by the faces of adjacent framing.

- C. Extend partition framing above suspended ceilings. Continue framing over frames for doors and openings and frame around ducts penetrating partitions above ceiling to provide support for gypsum board.
  - 1. Cut studs 1/2 inch (13 mm) short of full height to provide perimeter relief.
  - 2. Where partitions do not extend to bottom of structure, provide bracing members, of same size as metal stud framing, at approximately 6 feet (1.83 m) spacings. Secure braces to structure above. Set braces at approximately 1-on-1 slope, alternate sides.
- D. Install steel studs and furring at the following spacings: 16 inches (406 mm) o.c., unless otherwise indicated.
- E. Install steel studs so flanges point in the same direction and leading edge or end of each panel can be attached to open (unsupported) edges of stud flanges first.
- F. Partition Bridging: Continuous metal channel horizontal bridging at 4-foot centers.

### 3.4 APPLYING PANELS, GENERAL

- A. Gypsum Board Application and Finishing Standards: ASTM C 840 and GA-216.
- B. At the wall separating the 2 restrooms, install sound attenuation blankets before installing gypsum panels.
- C. Locate edge and end joints over supports. Stagger vertical joints on opposite sides of partitions.
- D. Cover both faces of steel stud partition framing with panels in concealed spaces (above ceilings, etc.).
- E. Space fasteners in panels according to referenced application and finishing standard and manufacturer's written recommendations.
  - 1. Space fasteners in panels that are tile substrates a maximum of 8 inches (203.2 mm) o.c.

### 3.5 PANEL APPLICATION METHODS

- A. Single-Layer Application: On partitions/walls, apply panels either vertically (parallel to framing) or horizontally (perpendicular to framing), and minimize end joints. Stagger abutting end joints not less than one framing member in alternate courses of board.
  - 1. Single-Layer Fastening Methods: Apply panels to supports with steel drill screws.
- B. Tile Backing Panels:
  - 1. Water-Resistant Gypsum Backing Board: Install at toilet rooms and walls behind plumbing fixtures. Install with 1/4-inch (6.4-mm) gap where panels abut other construction or penetrations.
  - 2. Where tile backing panels abut other types of panels in the same plane, shim surfaces to produce a uniform plane across panel surfaces.

### 3.6 INSTALLING TRIM ACCESSORIES

- A. General: For trim with back flanges intended for fasteners, attach to framing with same fasteners used for panels. Otherwise, attach trim according to manufacturer's written instructions.

### 3.7 FINISHING

- A. General: Treat gypsum board joints, interior angles, edge trim, control joints, penetrations, fastener heads, surface defects, and elsewhere as required to prepare gypsum board surfaces for decoration. Promptly remove residual joint compound from adjacent surfaces.
- B. Prefill open joints, and damaged surface areas.
- C. Apply joint tape over gypsum board joints, except those with trim having flanges not intended for tape.
- D. Gypsum Board Finish Levels: Finish panels to levels indicated below, according to ASTM C 840, for locations indicated:
  - 1. Level 1: Embed tape at joints in ceiling plenum areas, concealed areas.
  - 2. Level 2: Embed tape and apply separate first coat of joint compound to tape, fasteners, and trim flanges where panels are substrate for tile.
  - 3. Level 4: Embed tape and apply separate first, fill, and finish coat of joint compound to tape, fasteners, and trim flanges; for gypsum wallboard surfaces to be painted in Janitor Closet.

### 3.8 PROTECTION

- A. Protect adjacent surfaces from drywall compound and promptly remove from floors and other non-drywall surfaces. Repair surfaces stained, marred, or otherwise damaged during drywall application.
- B. Protect installed products from damage from weather, condensation, direct sunlight, construction, and other causes during remainder of the construction period.
- C. Remove and replace panels that are wet, moisture damaged, and mold damaged.
  - 1. Indications that panels are wet or moisture damaged include, but are not limited to, discoloration, sagging, or irregular shape.
  - 2. Indications that panels are mold damaged include, but are not limited to, fuzzy or splotchy surface contamination and discoloration.

END OF SECTION 09 21 16



## SECTION 09 31 00 - CERAMIC TILE

### PART 1 - GENERAL

#### 1.1 SUMMARY

- A. This Section includes the following:
  - 1. Ceramic floor and wall tile.
  - 2. Waterproof membrane .
  - 3. Crack-suppression.
  - 4. Stone thresholds installed as part of tile installations.
- B. Related Sections include the following:
  - 1. Division 7 - Sealants.

#### 1.2 PERFORMANCE REQUIREMENTS

- A. Static Coefficient of Friction: For floor tiles, provide products with values as determined by testing identical products per ASTM C 1028: Minimum 0.6.

#### 1.3 SUBMITTALS

- A. Product Data: For each type of product indicated.
- B. Samples for Verification of Selection: For each type of tile and grout indicated. Include Samples of accessories involving color selection.

#### 1.4 QUALITY ASSURANCE

- A. Source Limitations for Tile: Obtain tile of same type and color or finish from one source or producer.
  - 1. Obtain tile from same production run and of consistent quality in appearance and physical properties for each contiguous area.
- B. Source Limitations for Setting and Grouting Materials: Obtain ingredients of a uniform quality for each mortar, adhesive, and grout component from a single manufacturer and each aggregate from one source or producer.

#### 1.5 DELIVERY, STORAGE, AND HANDLING

- A. Deliver and store packaged materials in original containers with seals unbroken and labels intact until time of use. Comply with requirement in ANSI A137.1 for labeling sealed tile packages.
- B. Store tile and cementitious materials on elevated platforms, under cover, and in a dry location.
- C. Store aggregates where grading and other required characteristics can be maintained and contamination avoided.

#### 1.6 PROJECT CONDITIONS

- A. Environmental Limitations: Do not install tile until construction in spaces is complete and ambient temperature and humidity conditions are maintained at the levels indicated in referenced standards and manufacturer's written instructions.

## PART 2 - PRODUCTS

### 2.1 TILE PRODUCTS

- A. Tile Floor and Wall and Base Units: As indicated in Drawings.
- B. Trim: Stainless steel formed bullnose corners and coved base by Schluter, or approved equal.

### 2.2 THRESHOLDS

- A. General: Fabricate to sizes and profiles indicated or required to provide transition between adjacent floor finishes.
  - 1. Bevel edges at 1:2 slope, aligning lower edge of bevel with adjacent floor finish. Limit height of bevel to 1/2 inch (12.7 mm) or less, and finish bevel to match face of threshold.
- B. Marble Thresholds: ASTM C 503 with a minimum abrasion resistance of [10] [12] per ASTM C 1353 or ASTM C 241 and with honed finish.

### 2.3 WATERPROOFING AND CRACK-SUPPRESSION MEMBRANES

- A. General: Manufacturer's standard product that complies with ANSI A118.10, selected from any one the following at Contractor's option:-
- B. Unreinforced, Fluid-Applied Product: Liquid-latex rubber in a consistency suitable for trowel application and intended for use as waterproofing. Products:
  - 1. Boiardi Products Corporation; Elastiment [324] [644].
  - 2. Custom Building Products; LevelQuick Waterproofing and Anti-Fracture Membrane.
  - 3. Jamo Inc.; Waterproof.
- C. Urethane Waterproofing and Tile-Setting Adhesive: One-part liquid-applied urethane in a consistency suitable for trowel application and intended for use as both waterproofing and tile-setting adhesive in a two-step process. Products:
  - 1. Bostik; Hydroment Ultra-Set.
  - 2. Southern Grouts & Mortars, Inc.; Deck-Seal 1000.

### 2.4 SETTING AND GROUTING MATERIALS

- A. Portland Cement Mortar:
  - 1. Portland Cement: ASTM C-150 Type 1
  - 2. Sand: ASTM C144
  - 3. Water: potable
  - 4. Reinforcement: 6 gage (4 mm) welded wire mesh.
- B. Floor Setting Materials:

1. Thin set: Latex Portland Cement mortar bond coat, ANSI A118.4.
- C. Wall Setting Materials: Dry set mortar or latex portland cement mortar on a cured bed conforming to ANSI A118.1 or A118.4.
  1. For wall applications, provide non-sagging mortar that complies with Paragraph C-4.6.1 in addition to the other requirements in ANSI A118.1. or Paragraph F-4.6.1 in addition to the other requirements in ANSI A118.4..
- D. Grout: Water-Cleanable, Tile-Setting and -Grouting Epoxy, ANSI A118.3.
- E. Manufacturers:
  1. Boiardi Products Corporation.
  2. Bonsal, W. R., Company.
  3. Bostik.
  4. C-Cure.
  5. Custom Building Products.
  6. DAP, Inc.
  7. LATICRETE International Inc.
  8. MAPEI Corporation.
  9. Southern Grouts & Mortars, Inc.
  10. Summitville Tiles, Inc.
  11. TEC Specialty Products Inc.

## 2.5 ELASTOMERIC SEALANTS

- A. General: Provide manufacturer's standard chemically curing, elastomeric sealants of base polymer and characteristics indicated that comply with applicable requirements in Division 7 Section "Joint Sealants."
- B. Colors: Provide colors of exposed sealants to match colors of grout in tile adjoining sealed joints, unless otherwise indicated.
- C. One-Part, Mildew-Resistant Silicone Sealant: ASTM C 920; Type S; Grade NS; Class 25; Uses NT, G, A, and, as applicable to nonporous joint substrates indicated, O; formulated with fungicide, intended for sealing interior ceramic tile joints and other nonporous substrates that are subject to in-service exposures of high humidity and extreme temperatures. Products:
  1. Dow Corning Corporation; Dow Corning 786.
  2. GE Silicones; Sanitary 1700.
  3. Pecora Corporation; Pecora 898 Sanitary Silicone Sealant.
  4. Tremco, Inc.; Tremsil 600 White.

## 2.6 MISCELLANEOUS MATERIALS

- A. Trowelable Underlayments and Patching Compounds: Latex-modified, portland cement-based formulation provided or approved by manufacturer of tile-setting materials for installations indicated.
- B. Tile Cleaner: A neutral cleaner capable of removing soil and residue without harming tile and grout surfaces, specifically approved for materials and installations indicated by tile and grout manufacturers.

- C. Grout Sealer: Manufacturer's standard silicone product for sealing grout joints that does not change color or appearance of grout. Products:
  - 1. Bonsal, W. R., Company; Grout Sealer.
  - 2. Bostik; CeramaSeal Grout Sealer.
  - 3. C-Cure; Penetrating Sealer 978.
  - 4. Custom Building Products; Grout and Tile Sealer.
  - 5. MAPEI Corporation; KER [003, Silicone Spray Sealer for Cementitious Tile Grout.
  - 6. Southern Grouts & Mortars, Inc.; Silicone Grout Sealer.
  - 7. Summitville Tiles, Inc.; SL-15, Invisible Seal Penetrating Grout and Tile Sealer.
  - 8. TEC Specialty Products Inc.; TA-257 Silicone Grout Sealer.

## 2.7 MIXING MORTARS AND GROUT

- A. Mix mortars and grouts to comply with referenced standards and mortar and grout manufacturers' written instructions.
- B. Add materials, water, and additives in accurate proportions.
- C. Obtain and use type of mixing equipment, mixer speeds, mixing containers, mixing time, and other procedures to produce mortars and grouts of uniform quality with optimum performance characteristics for installations indicated.

## PART 3 - EXECUTION

### 3.1 EXAMINATION

- A. Examine substrates, areas, and conditions where tile will be installed for compliance with requirements for installation tolerances and other conditions affecting performance.
  - 1. Verify that substrates for setting tile are firm; dry; clean; free of oil, waxy films, and curing compounds; and within flatness tolerances required by referenced ANSI A108 Series of tile installation standards for installations indicated.
  - 2. Verify that installation of anchors, recessed frames, electrical and mechanical units of work, and similar items located in or behind tile has been completed before installing tile.
- B. Make correction so unsatisfactory conditions.

### 3.2 PREPARATION

- A. Remove coatings, including curing compounds and other substances that contain soap, wax, oil, or silicone, that are incompatible with tile-setting materials.
- B. Provide concrete substrates for tile floors that comply with flatness tolerances specified in referenced ANSI A108 Series of tile installation standards.
  - 1. Fill cracks, holes, and depressions with trowelable leveling and patching compound according to tile-setting material manufacturer's written instructions. Use product specifically recommended by tile-setting material manufacturer.
  - 2. Remove protrusions, bumps, and ridges by sanding or grinding.

- C. Blending: For tile exhibiting color variations within ranges selected during Sample submittals, verify that tile has been factory blended and packaged so tile units taken from one package show same range of colors as those taken from other packages and match approved Samples. If not factory blended, either return to manufacturer or blend tiles at Project site before installing.

### 3.3 INSTALLATION, GENERAL

- A. ANSI Tile Installation Standards: Comply with parts of ANSI A108 Series "Specifications for Installation of Ceramic Tile" that apply to types of setting and grouting materials and to methods indicated in ceramic tile installation schedules.
- B. TCA Installation Guidelines: TCA's "Handbook for Ceramic Tile Installation." Comply with TCA installation methods indicated in ceramic tile installation schedules.
- C. Extend tile work into recesses and under or behind equipment and fixtures to form complete covering without interruptions, unless otherwise indicated. Terminate work neatly at obstructions, edges, and corners without disrupting pattern or joint alignments.
- D. Accurately form intersections and returns. Perform cutting and drilling of tile without marring visible surfaces. Carefully grind cut edges of tile abutting trim, finish, or built-in items for straight aligned joints. Fit tile closely to electrical outlets, piping, fixtures, and other penetrations so plates, collars, or covers overlap tile.
- E. Jointing Pattern: Lay tile in grid pattern, unless otherwise indicated. Align joints when adjoining tiles on floor, base, walls, and trim are same size. Lay out tile work and center tile fields in both directions in each space or on each wall area. Adjust to minimize tile cutting. Provide uniform joint widths, unless otherwise indicated.
- F. Lay out tile wainscots to next full tile beyond dimensions indicated.
- G. Expansion Joints: Provide expansion joints and other sealant-filled joints, including control, contraction, and isolation joints, where indicated. Form joints during installation of setting materials, mortar beds, and tile. Do not saw-cut joints after installing tiles.
  - 1. Where joints occur in concrete substrates, locate joints in tile surfaces directly above them.
  - 2. Prepare joints and apply sealants to comply with requirements in Division 07 Section "Joint Sealants."
- H. Grout Sealer: Apply grout sealer to cementitious grout joints according to grout-sealer manufacturer's written instructions. As soon as grout sealer has penetrated grout joints, remove excess sealer and sealer from tile faces by wiping with soft cloth.

### 3.4 WATERPROOFING AND CRACK-SUPPRESSION MEMBRANE INSTALLATION

- A. Comply with waterproofing manufacturer's written installation instructions to produce a membrane of uniform thickness bonded securely to substrate. Install waterproof membrane to provide monolithic pan in each area.
- B. Extend waterproofing membrane up wall base to form waterproof envelope pan for each area. At door sills, extend up slab depression edge.

- C. Install waterproofing to comply with ANSI A108.13 and waterproofing manufacturer's written instructions to produce waterproof membrane of uniform thickness bonded securely to substrate.
- D. Install crack-suppression membrane to comply with manufacturer's written instructions to produce membrane of uniform thickness bonded securely to substrate.
- E. Do not install tile over waterproofing until waterproofing has cured and been tested to determine that it is watertight.

### 3.5 COLOR, PATTERN DESIGN

- A. Provide colors and design patterns as indicated in the drawings.

### 3.6 FLOOR TILE INSTALLATION

- A. General: Install tile to comply with requirements in the Floor Tile Installation Schedule, including those referencing TCA installation methods and ANSI A108 Series of tile installation standards.
- B. Ceramic Floor Tile Installations: F115 Thinset method. Floor tile installed thinset over concrete substrate.
- C. Joint Widths: Install tile on floors with the following joint widths:
  - 1. Ceramic Mosaic Tile: 1/8 inch (3 mm).
- D. Grout: Epoxy, ANSI A108.6.
- E. Stone Thresholds: Install stone thresholds where exposed edge of tile flooring meets other flooring. Set threshold in same type of setting bed as abutting field tile, unless otherwise indicated.

### 3.7 WALL TILE INSTALLATION

- A. Install types of tile designated for wall installations to comply with requirements in the Wall Tile Installation Schedule, including those referencing TCA installation methods and ANSI setting-bed standards.
- B. Wall Base Tile
  - 1. Concrete Block: TCA W202. Dry-set or Latex Portland Cement Mortar, tile installation to concrete block wall surface.
- C. Grout: Epoxy, ANSI A108.6.
  - 1. Omit grout at wall interior wall corners, and where tile abut construction such as door frames. Provide sealant at these joints.
  - 2.
- D. Joint Widths: Install tile on walls with the following joint widths:
  - 1. Glazed Wall Tile: 1/8 inch (3 mm).

### 3.8 ADJUSTING AND CLEANING

- A. Remove and replace tile that is damaged or that does not match adjoining tile. Provide new matching units, installed as specified and in a manner to eliminate evidence of replacement.
- B. Cleaning: On completion of placement and grouting, clean all ceramic tile surfaces so they are free of foreign matter.
  - 1. Remove grout residue from tile as soon as possible.
  - 2. Clean grout smears and haze from tile according to tile and grout manufacturer's written instructions but no sooner than 10 days after installation. Use only cleaners recommended by tile and grout manufacturers and only after determining that cleaners are safe to use by testing on samples of tile and other surfaces to be cleaned. Protect metal surfaces and plumbing fixtures from effects of cleaning. Flush surfaces with clean water before and after cleaning.

### 3.9 PROTECTION

- A. Protect installed tile work with kraft paper or other heavy covering during construction period to prevent staining, damage, and wear. If recommended by tile manufacturer, apply coat of neutral protective cleaner to completed tile walls and floors.
- B. Prohibit foot and wheel traffic from tiled floors for at least seven days after grouting is completed.
- C. Before final inspection, remove protective coverings and rinse neutral protective cleaner from tile surfaces.

END OF SECTION 09 31 00

## SECTION 09 51 00 - ACOUSTICAL PANEL CEILING SYSTEM

### PART 1 - GENERAL

#### 1.1 SUMMARY

- A. This Section includes acoustical panels and exposed suspension system.

#### 1.2 SUBMITTALS

- A. Submit product data.

#### 1.3 QUALITY ASSURANCE

- A. Source Limitations:
  - 1. Acoustical Ceiling Panel: Obtain through one source from a single manufacturer.
  - 2. Suspension System: Obtain through one source from a single manufacturer.
- B. Fire-Test-Response Characteristics:
  - 1. Surface-Burning Characteristics: Comply with ASTM E 1264 for Class A materials as determined by testing identical products per ASTM E 84:
    - a. Flame spread: 25 or less.
    - b. Smoke-Developed Index: 450 or less.
- C. Coordinate layout and installation of acoustical panels and suspension system with other construction that penetrate ceilings or is supported by them, including light fixtures, equipment and partitions.

#### 1.4 EXTRA MATERIALS

- A. Furnish extra materials of products installed and that are packaged with protective covering for storage and identified with labels describing contents.
  - 1. Acoustical Ceiling Panels: 2 boxes full-size panels.

### PART 2 - PRODUCTS

#### 2.1 ACOUSTICAL CEILING PANELS

- A. Acoustical Panel Standard: ASTM E 1264.
- B. Acoustical Panels: Ceiling tile panel for toilet rooms.
  - 1. Basis-of-Design Product: Subject to compliance with requirements, provide Armstrong Clean Room VL #868, or a comparable product by one of the following:
    - a. Rockfon
    - b. USG Interiors, Inc.
    - c. BPB USA
  - 2. Performance Characteristics
    - a. Mineral fiber, smooth texture vinyl-face membrane, unperforated.
    - b. Modular Size: 24 by 24 inches (610 by 610 mm)
    - c. Thickness: 5/8-inch



- d. Edge/Joint Detail: Square
- e. LR: 0.80
- f. NRC: n/a
- g. CAC: 40
- h. Humidity Resistant treated, HumiGuard Plus
- i. Clean Room Class 100
- j. Antimicrobial treated, Bioblock
- k. Color: White

## 2.2 METAL SUSPENSION SYSTEM

- A. Metal Suspension System Standard: Manufacturer's standard direct-hung metal suspension systems of types, structural classifications, and finishes indicated that comply with applicable requirements in ASTM C 635.
  - 1. Finishes and Colors, General: Comply with NAAMM's "Metal Finishes Manual for Architectural and Metal Products" for recommendations for applying and designating finishes. Provide manufacturer's standard factory-applied finish for type of system indicated.
  - 2. Attachment Devices: Size for five times the design load indicated in ASTM C 635, Table 1, "Direct Hung," unless otherwise indicated.
  - 3. Wire Hangers, Braces, and Ties:
    - a. Zinc-Coated Carbon-Steel Wire: ASTM A 641/A 641M, Class 1 zinc coating, soft temper.
    - b. Size: Select wire diameter so its stress at three times hanger design load (ASTM C 635, Table 1, "Direct Hung") will be less than yield stress of wire, but provide not less than 0.106-inch- (2.69-mm-) diameter wire.
  - 4. Hangers: Mild steel, zinc coated or protected with rust-inhibitive paint.
  - 5. Hold-Down Clips: Where indicated, provide manufacturer's standard hold-down clips spaced 24 inches (610 mm) o.c. on all cross tees.
- B. Manufacturer & Product: Products by ceiling tile panel manufacturer; Basis-of Design Prelude XL by Armstrong; or approved equal.
- C. Exposed Tee System, Hot-Dip Galvanized Steel Suspension System: Main and cross runners roll formed from cold-rolled steel sheet, hot-dip galvanized according to ASTM A 653/A 653M coating designation.
  - 1. Width: 15/16-inch, unless indicated otherwise.
  - 2. Structural Classification: Intermediate-duty system.
  - 3. Face Design: Flat, flush.
  - 4. Face Finish: Painted white.
- D. Roll-Formed Metal Edge Moldings and Trim: Type and profile indicated or, if not indicated, manufacturer's standard moldings for edges and penetrations that fit acoustical panel edge details and suspension systems indicated; formed from sheet metal of same material, finish, and color as that used for exposed flanges of suspension system runners.
  - 1. For circular penetrations of ceiling, provide edge moldings fabricated to diameter required to fit penetration exactly.
  - 2. Moldings and trim abutting straight wall condition shall be shadow type moldings with 1/2-inch reveals.

## PART 3 - EXECUTION

### 3.1 EXAMINATION AND PREPARATION

- A. Examine substrates, areas, and conditions, including structural framing to which acoustical panel ceilings attach or abut, for compliance with requirements that affect ceiling installation and anchorage and with requirements for installation tolerances and other conditions affecting performance of acoustical panel ceilings.
- B. Measure each ceiling area and establish layout of acoustical panels to balance border widths at opposite edges of each ceiling. Avoid using less-than-half-width panels at borders, and comply with layout shown on reflected ceiling plans.
- C. Make corrections to unsatisfactory conditions.

### 3.2 INSTALLATION, GENERAL

- A. General: Install acoustical panel ceilings to comply with ASTM C 636 requirements, per manufacturer's written instructions and CISCA's "Ceiling Systems Handbook."
- B. Suspend ceiling hangers from building's structural members and as follows:
  - 1. Install hangers plumb and free from contact with insulation or other objects within ceiling plenum that are not part of supporting structure or of ceiling suspension system.
  - 2. Splay hangers only where required to miss obstructions; offset resulting horizontal forces by bracing, countersplaying, or other equally effective means.
  - 3. Where width of ducts and other construction within ceiling plenum produces hanger spacings that interfere with location of hangers at spacings required to support standard suspension system members, install supplemental suspension members and hangers in form of trapezes or equivalent devices. Size supplemental suspension members and hangers to support ceiling loads within performance limits established by referenced standards and publications.
  - 4. Secure wire hangers to ceiling suspension members and to supports above with a minimum of three tight turns. Connect hangers directly either to structures or to inserts, eye screws, or other devices that are secure and appropriate for substrate and that will not deteriorate or otherwise fail due to age, corrosion, or elevated temperatures.
  - 5. Do not support ceilings directly from permanent metal forms or floor deck. Fasten hangers to cast-in-place hanger inserts, post-installed mechanical or adhesive anchors, or power-actuated fasteners that extend through forms into concrete.
  - 6. Attach hangers to structural members.
  - 7. Space hangers not more than 48 inches o.c. along each member supported directly from hangers, unless otherwise indicated; provide hangers not more than 8 inches (200 mm) from ends of each member.
  - 8. Provide additional grid hangers at each corner of each lay-in light fixture, i.e. 4 hanger wires total each light).
- C. Install edge moldings and trim of type indicated at perimeter of acoustical ceiling area and where necessary to conceal edges of acoustical panels.

- D. Install suspension system runners so they are square and securely interlocked with one another. Remove and replace dented, bent, or kinked members.
- E. Install acoustical panels with undamaged edges and fit accurately into suspension system runners and edge moldings. Scribe and cut panels at borders and penetrations to provide a neat, precise fit.

### 3.3 CLEANING

- A. Clean exposed surfaces of acoustical panel ceilings, including trim, edge moldings, and suspension system members.
- B. Comply with manufacturer's written instructions for cleaning and touchup of minor finish damage.
- C. Remove and replace ceiling components that cannot be successfully cleaned and repaired to permanently eliminate evidence of damage.

END OF SECTION 09 51 00

## SECTION 09 65 00 - RESILIENT MATERIALS

### PART 1 - GENERAL

#### 1.1 SUMMARY

- A. Types of resilient flooring materials specified include:
  - 1. Resilient base.
  - 2.

#### 1.2 QUALITY ASSURANCE

- A. Resilient materials, including accessories such as underlayment and adhesive, must be free of asbestos.

#### 1.3 SUBMITTALS

- A. Product Data: Submit manufacturer's product information of each flooring system showing compliance with project requirements.
- B. Samples for Verification of Selection: Submit 2 full size of each type of resilient base samples for verification of selection.
  - 1. Submit samples of other colors upon request.

#### 1.4 PROJECT CONDITIONS

- A. Maintain minimum temperature of 65 °F (18 C) in spaces to receive resilient materials for at least 48 hours before, during and after installation. Store resilient materials in same conditions for at least 48 hours before the installation.
- B. Sequence resilient material installation after painting and finishing operations. Ensure that concrete substrates are adequately cured and dry to achieve the bond with adhesive in accordance with manufacturer's requirements.

#### 1.5 EXTRA MATERIALS

- A. Furnish extra materials described below that match products installed and that are packaged with protective covering for storage and identified with labels describing contents.
  - 1. Base: Not less than 50-ft. of each color.

### PART 2 - PRODUCTS

#### 2.1 RESILIENT MATERIALS

- A. Resilient Base Products:
  - 1. Rubber and Vinyl Base: 4 inches high x 1/8 inch thick (102 x 3 mm), top set covered, matte finish, unless indicated otherwise.

- a. External Corners: Provide field-formed corners. Scoring or scribe back of base to coincide with edge of corner, heat-treat to retain the position and secure in place with adhesive. Fasteners are not permitted. Extend each leg a minimum of 12 inches each side of corner.
  - b. Internal Corners: Cut to provide neat butt joint.
- B. Colors and Patterns: As indicated, if not indicated, as selected from manufacturer's full range of available colors.
- 1. Different colors selected for different rooms and buildings.

## 2.2 INSTALLATION MATERIALS AND ACCESSORIES

### PART 3 - EXECUTION

#### 3.1 EXAMINATION

- A. Examine substrates, with Installer present, for compliance with requirements for maximum moisture content and other conditions affecting performance of the Work.
  - 1. Verify that finishes of substrates comply with tolerances and other requirements specified in other Sections and that substrates are free of cracks, ridges, depressions, scale, and foreign deposits that might interfere with adhesion of floor tile.
- B. Make corrections to unsatisfactory conditions.

#### 3.2 PREPARATION

- A. Prepare substrates according to base manufacturer's written instructions to ensure adhesion of resilient products.

#### 3.3 APPLICATION OF ADHESIVES

- A. Mix and apply adhesives in accordance with manufacturer's instructions.
- B. Provide safety precautions during mixing and applications as recommended by adhesive manufacturer.

#### 3.4 INSTALLATION – GENERAL

- F. Base: Make neat joints. Lay out in advance such that length of wall before applying the material. Avoid pieces less than 3 feet (0.9 m) long. Apply to provide continuous appearance.

END OF SECTION 09 65 00

## SECTION 09 90 00 - PAINTING

### PART 1 - GENERAL

#### 1.1 SUMMARY

- A. The work includes surface preparation and field painting of new and indicated existing exposed items and surfaces. Surfaces to be painted include, but are not necessarily limited to:
  - 1. Existing and new metal door frames
  - 2. Existing and new concrete block
  - 3. Existing wood doors
  - 4. New gypsum wallboard
  - 5. New doors and frames

#### 1.2 SUBMITTALS

- A. Product Data: For each paint system indicated. Include primers.
  - 1. Material List: An inclusive list of required coating materials. Indicate each material and cross-reference specific coating, finish system, and application. Identify each material by manufacturer's catalog number and general classification.
  - 2. Manufacturer's Information: Manufacturer's technical information, including label analysis and instructions for handling, storing, and application.

#### 1.3 QUALITY ASSURANCE

- A. Source Limitations: Obtain primers for each coating system from the same manufacturer as the finish coats.

### PART 2 - PRODUCTS

#### 2.1 MANUFACTURERS

- A. Products: Subject to compliance with requirements, provide one of the products listed in other Part 2 articles.
- B. Manufacturers' Names: Shortened versions (shown in parentheses) of the following manufacturers' names are used in other Part 2 articles:
  - 1. Benjamin Moore & Co. (Benjamin Moore).
  - 2. Farrell-Calhoun
  - 3. PPG Industries, Inc. (Pittsburgh Paints).
  - 4. Sherwin-Williams Co. (Sherwin-Williams).

#### 2.2 PAINT MATERIALS, GENERAL

- A. Material Compatibility: Provide primers, and finish-coat materials that are compatible with one another and with the substrates indicated under conditions of service and application, as demonstrated by manufacturer based on testing and field experience.

- B. Material Quality: Provide manufacturer's best-quality paint material of the various coating types specified that are factory formulated and recommended by manufacturer for application indicated. Paint-material containers not displaying manufacturer's product identification will not be acceptable.
- C. Colors: Match existing colors of similar adjacent materials; and as indicated in Drawings

## 2.3 CONCRETE UNIT MASONRY BLOCK FILLERS

- A. Concrete Unit Masonry Block Filler: Factory-formulated high-performance latex block fillers.
  - 1. Benjamin Moore; Moorcraft Super Craft Latex Block Filler No. 285: Applied at a dry film thickness of not less than 8.1 mils (0.206 mm).
  - 2. Farrell-Calhoun: #470 Latex Masonry Block Filler.
  - 3. Pittsburgh Paints; 6-7 SpeedHide Interior/Exterior Masonry Latex Block Filler: Applied at a dry film thickness of not less than 6.0 to 12.5 mils (0.152 to 0.318 mm).
  - 4. Sherwin-Williams; PrepRite Interior/Exterior Block Filler B25W25: Applied at a dry film thickness of not less than 8.0 mils (0.203 mm).

## 2.4 PAINT PRIMERS

- A. Interior Masonry Primer for concrete block: Factory-formulated alkali-resistant acrylic-latex primer.
  - 1. Benjamin Moore; Regal FirstCoat Interior Latex Primer & Underbody No. 216: Applied at a dry film thickness of not less than 1.0 mil (0.025 mm).
  - 2. Farrell-Calhoun: # 235 100% Acrylic Latex Undercoater.
  - 3. Pittsburgh Paints; 6-2 SpeedHide Interior Quick-Drying Latex Sealer: Applied at a dry film thickness of not less than 1.0 mil (0.025 mm).
  - 4. Sherwin-Williams; PrepRite Masonry Primer B28W300: Applied at a dry film thickness of not less than 3.0 mils (0.076 mm).
- B. Interior Gypsum Board Primer: Factory-formulated latex-based primer.
  - 1. Benjamin Moore; Regal FirstCoat Interior Latex Primer & Underbody No. 216: Applied at a dry film thickness of not less than 1.0 mil (0.025 mm).
  - 2. Farrell-Calhoun: # 380 Latex Primer/Sealer.
  - 3. Pittsburgh Paints; 6-2 SpeedHide Interior Quick-Drying Latex Sealer: Applied at a dry film thickness of not less than 1.0 mil (0.025 mm).
  - 4. Sherwin-Williams; PrepRite Masonry Primer B28W300 Series: Applied at a dry film thickness of not less than 3.0 mils (0.076 mm).

## 2.5 FINISH COATS

- A. Gloss Acrylic Enamel for Ferrous and Other Metals: Factory-formulated full-gloss waterborne acrylic-latex enamel.
  - 1. Benjamin Moore; Impervex Metal & Wood Enamel No. 309: Applied at a dry film thickness of not less than 1.2 mils (0.031 mm).
  - 2. Farrell-Calhoun: # 2400 Line 100% Acrylic Latex.
  - 3. Pittsburgh Paints; 51-Line Brilliant Reflections Latex Enamel: Applied at a dry film thickness of not less than 1.3 mils (0.033 mm).
  - 4. Sherwin-Williams; DTM Acrylic Coating (Waterborne) B66W100 Series: Applied at a dry film thickness of not less than 2.4 mils (0.061 mm).

- B. Semi-Gloss Acrylic Paint for interior concrete block: Factory-formulated acrylic-emulsion latex paint.
  - 1. Benjamin Moore; Regal Wall Satin No. 215 Premium Interior Finish: Applied at a dry film thickness of not less than 1.3 mils (0.033 mm).
  - 2. Farrell-Calhoun: #300 Line Interior paint.
  - 3. Pittsburgh Paints; 80-Line Wallhide Interior Wall Paint: Applied at a dry film thickness of not less than 1.2 mils (0.031 mm).
  - 4. Sherwin-Williams; SuperPaint Interior Latex Wall Paint, A86 Series: Applied at a dry film thickness of not less than 1.5 mils (0.038 mm).

## 2.6 INTERIOR WOOD STAINS AND VARNISHES

- A. Open-Grain Wood Filler: Factory-formulated paste wood filler applied at spreading rate recommended by manufacturer.
  - 1. Benjamin Moore; Benwood Paste Wood Filler No. 238.
  - 2. Farrell-Calhoun: Paste-wood filler.
  - 3. Pittsburgh Paints; none required.
  - 4. Sherwin-Williams; Sher-Wood Fast-Dry Filler.
- B. Interior Wood Stain: Factory-formulated alkyd-based penetrating wood stain for interior application applied at spreading rate recommended by manufacturer.
  - 1. Benjamin Moore; Benwood Penetrating Stain No. 234.
  - 2. Farrell-Calhoun: WoodKraft Penetrating Wiping Stain.
  - 3. Pittsburgh Paints; 77-560 Rez Interior Semi-Transparent Oil Stain.
  - 4. Sherwin-Williams; Wood Classics Interior Oil Stain A-48 Series.
- C. Clear Sanding Sealer: Factory-formulated fast-drying alkyd-based clear wood sealer applied at spreading rate recommended by manufacturer.
  - 1. Benjamin Moore; Moore's Interior Wood Finishes Quick-Dry Sanding Sealer No. 413.
  - 2. Farrell-Calhoun: WoodKraft #1100 Satin Sealer Varnish.
  - 3. Pittsburgh Paints; 6-10 SpeedHide Quick-Drying Interior Sanding Wood Sealer and Finish.
  - 4. Sherwin-Williams; Wood Classics Fast Dry Sanding Sealer B26V43.
- D. Interior Polyurethane-Based Clear Satin Varnish: Factory-formulated alkyd- or polyurethane-based clear varnish.
  - 1. Benjamin Moore; Benwood Interior Wood Finishes Polyurethane Finishes Low Lustre No. 435.
  - 2. Farrell-Calhoun: #1120 Polyurethane Satin Gloss Varnish.
  - 3. Pittsburgh Paints; 77-7 Rez Varnish, Interior Satin Oil Clear.
  - 4. Sherwin-Williams: Polyurethane Varnish, Satin A67F1.

## PART 3 - EXECUTION

### 3.1 EXAMINATION

- A. Examine substrates, areas, and conditions for compliance with requirements for paint application. Comply with procedures specified in PDCA P4.
  - 1. Make corrections to unsatisfactory conditions.



### 3.2 PREPARATION

- A. General: Temporarily remove fixtures, hardware and hardware accessories, and similar items already installed that are not to be painted. If removal is impractical or impossible because of size or weight of the item, provide surface-applied protection before surface preparation and painting.
  - 1. After completing painting operations in each space or area, reinstall items removed using workers skilled in the trades involved.
- B. Cleaning: Before applying paint, clean substrates of substances that could impair bond of the various coatings. Remove oil and grease before cleaning.
  - 1. Schedule cleaning and painting so dust and other contaminants from the cleaning process will not fall on wet, newly painted surfaces.
- C. Surface Preparation: Clean and prepare surfaces to be painted according to manufacturer's instructions.
  - 1. Provide barrier coats over incompatible primers or remove and reprime.
  - 2. Cementitious Materials: Prepare concrete and plaster surfaces to be painted. Remove efflorescence, chalk, dust, dirt, grease, oils, and release agents. Roughen as required to remove glaze. If hardeners or sealers have been used to improve curing, use mechanical methods of surface preparation.
    - a. Determine alkalinity and moisture content of surfaces by performing appropriate tests. If surfaces are sufficiently alkaline to cause the finish paint to blister and burn, correct this condition before application. Do not paint surfaces if moisture content exceeds that permitted in manufacturer's written instructions.
  - 3. Wood: Clean surfaces of dirt, oil, and other foreign substances with scrapers, mineral spirits, and sandpaper, as required. Sand surfaces exposed to view smooth and dust off.
  - 4. Ferrous Metals: Clean ungalvanized ferrous-metal surfaces that have not been shop coated; remove oil, grease, dirt, loose mill scale, and other foreign substances. Use solvent or mechanical cleaning methods that comply with SSPC's recommendations.
- D. Material Preparation: Mix and prepare paint materials according to manufacturer's written instructions.

### 3.3 APPLICATION

- A. General: Apply paint according to manufacturer's written instructions. Use applicators and techniques best suited for substrate and type of material.
  - 1. Paint surface treatments, and finishes are indicated in the paint schedules.
  - 2. Do not paint over dirt, rust, scale, grease, moisture, scuffed surfaces, or conditions detrimental to formation of a durable paint film.
  - 3. Provide finish coats that are compatible with primers used.
- B. Scheduling Painting: Apply first coat to surfaces that have been cleaned, pretreated, or otherwise prepared for painting as soon as practicable after preparation and before subsequent surface deterioration.
  - 1. The number of coats and film thickness required are the same regardless of application method. Do not apply succeeding coats until previous coat has cured as

- recommended by manufacturer. If sanding is required to produce a smooth, even surface according to manufacturer's written instructions, sand between applications.
2. Omit primer over metal surfaces that have been shop primed and touchup painted.
  3. Allow sufficient time between successive coats to permit proper drying. Do not recoat surfaces until paint has dried to where it feels firm, and does not deform or feel sticky under moderate thumb pressure, and until application of another coat of paint does not cause undercoat to lift or lose adhesion.
- C. Application Procedures: Apply paints and coatings by brush, roller, spray, or other applicators according to manufacturer's written instructions.
- D. Minimum Coating Thickness: Apply paint materials to manufacturer's recommended spreading rate to achieve dry film thickness indicated. Provide total dry film thickness of the entire system as recommended by manufacturer.
- E. Prime Coats: Before applying finish coats, apply a prime coat, as recommended by manufacturer, to material that is required to be painted or finished and that has not been prime coated by others. Recoat primed and sealed surfaces where evidence of suction spots or unsealed areas in first coat appears, to ensure a finish coat with no burn-through or other defects due to insufficient sealing.
- F. Pigmented (Opaque) Finishes: Completely cover surfaces as necessary to provide a smooth, opaque surface of uniform finish, color, appearance, and coverage. Cloudiness, spotting, holidays, laps, brush marks, runs, sags, ropiness, or other surface imperfections will not be acceptable.
- G. Completed Work: Match approved samples for color, texture, and coverage. Remove, refinish, or repaint work not complying with requirements.
- ### 3.4 CLEANING
- A. Cleanup: At the end of each workday, remove empty cans, rags, rubbish, and other discarded paint materials from Project site.
  - B. After completing painting, clean paint-spattered surfaces. Remove spattered paint without scratching or damaging adjacent finished surfaces.
- ### 3.5 PROTECTION
- A. Protect work, whether being painted or not, against damage from painting. Correct damage by cleaning, repairing or replacing, and repainting.
  - B. Provide "Wet Paint" signs to protect newly painted finishes. After completing painting operations, remove temporary protective wrappings.
    1. After work of other trades is complete, touch up and restore damaged or defaced painted surfaces. Comply with procedures specified in PDCA P1.
- ### 3.6 PAINT SCHEDULE
- A. Existing and New Concrete Block
    1. Block filler to new block

2. 1 coat - primer.
  3. 2 coats - semi-gloss acrylic enamel.
- B. Gypsum Wallboard
1. 1 coat - primer.
  2. 2 coats - semi-gloss acrylic enamel.
- C. Metals: Existing metal frames; new metal door frame.
1. 1 coat - primer.
  2. 2 coats - gloss acrylic enamel.
- D. Existing wood doors: Restore and re-finish. Clean, sand, stain and seal.
1. 1 coat - interior oil stain.
  2. 2 coats - satin polyurethane varnish.

END OF SECTION 09 90 00

## SECTION 10 14 00 - SIGNAGE

### PART 1 - GENERAL

#### 1.1 SUMMARY

- A. This Section includes
  1. Room Panel Signs.

#### 1.2 SUBMITTALS

- A. Submit room panel design and layout; schedule of room names and numbers, for verification of approval.

#### 1.3 QUALITY ASSURANCE

- A. Source Limitations: Obtain each sign type through one source from a single manufacturer.
- B. Regulatory Requirements: Comply with the Americans with Disabilities Act (ADA) and with code provisions as adopted by authorities having jurisdiction.

### PART 2 - PRODUCTS

#### 2.1 ROOM PANEL SIGNS

- A. Manufacturers:
  1. 2/90 Sign Systems
  2. Andco Industries Corp.
  3. APCO Graphics, Inc.
  4. ASI Sign Systems, Inc.
  5. Best Manufacturing Co.
- B. Description of Panel Signs: >>>
  1. Acrylic plastic with lettering and graphics.
  2. Copy: Tactile and Braille surface.
  3. Character Style: 1" tall, 1/8" stroke, Helvetica Medium style. All upper case letters.
  4. Size: 6-inches wide x 10-inches high. Height inclusive of 2-inch tall header.
  5. Room Numbers: Alpha-Numeric, 3-to-4 characters.
  6. ADA symbol: Include Universal Accessible sign for toilet rooms with handicap stalls.
- C. Cast-Acrylic Sheet: Manufacturer's standard and as follows:
  1. Transparent Sheet: Where sheet material is indicated as "clear," provide colorless sheet in matte finish, with light transmittance of 92 percent, when tested in accordance with the requirements of ASTM D 1003.



2. Opaque Sheet: Where sheet material is indicated as "opaque," provide colored opaque acrylic sheet in colors and finishes as selected from the manufacturer's standards.
    - a. Color: As selected by Architect from manufacturer's full range to match Owner's sample above.
  - D. Graphic Content and Style: Sign copy that complies with requirements indicated in the Sign Schedule for size, style, spacing, content, mounting height and location, material, finishes, and colors of signage.
  - E. Tactile and Braille Copy: Manufacturer's standard process for producing copy complying with ADA Accessibility Guidelines and ICC/ANSI A117.1. Text shall be accompanied by Grade 2 Braille. Produce precisely formed characters with square cut edges free from burrs and cut marks.
    1. Panel Material: Opaque acrylic sheet.
    2. Raised-Copy Thickness: Not less than 1/32 inch (0.8 mm).
  - F. Colored Coatings for Acrylic Sheet: For colors, provide Pantone Matching System (PMS) colored coatings, including inks and paints, that are recommended by acrylic manufacturers for optimum adherence to acrylic surface and are non-fading for application intended.
- ## 2.2 ACCESSORIES
- A. Double-Sided Adhesive Tape: Manufacturer's standard high-bond, foam-core tape, 0.045 inch (1.14 mm) thick, with adhesive on both sides.

## PART 3 - EXECUTION

### 3.1 EXAMINATION

- A. Examine substrates, areas, and conditions for compliance with requirements for installation tolerances and other conditions affecting performance of work.
- B. Make corrections to unsatisfactory conditions.

### 3.2 INSTALLATION

- A. General: Locate signs, using mounting methods of types described and in compliance with manufacturer's written instructions and ADA guidelines.
  1. Install signs level, plumb, and at heights indicated, with sign surfaces free from distortion and other defects in appearance.
  2. Before installation, verify that sign surfaces are clean and free of materials or debris that would impair installation.
  3. Interior Wall Signs: Install signs on walls adjacent to latch side of door where applicable. Where not indicated or possible, install signs on nearest adjacent walls. Locate to allow approach within 3 inches (75 mm) of sign without encountering protruding objects or standing within swing of door.

- B. Wall-Mounted Panel Signs: Attach panel signs to wall surfaces using double-sided adhesive tape.

### 3.3 CLEANING AND PROTECTION

- A. Remove and replace damaged or deformed characters and signs that do not comply with specified requirements. Replace characters with damaged or deteriorated finishes or components that cannot be successfully repaired by finish touchup or similar minor repair procedures.
- B. Remove temporary protective coverings and strippable films as signs are installed.
- C. After installation, clean soiled sign surfaces according to manufacturer's written instructions.

END OF SECTION 10 14 00

## SECTION 10 21 13 - PLASTIC TOILET COMPARTMENTS

### PART 1 - GENERAL

#### 1.1 SUMMARY

- A. Section Includes:
  - 1. Type: Solid-plastic toilet compartments configured as toilet enclosures.
  - 2. Compartment Style: Overhead braced and floor anchored.
  - 3. Screen Style: Wall hung and floor anchored.
  - 4. Signage
- B. Related Sections
  - 1. Division 10 "Toilet Accessories."

#### 1.2 ACTION SUBMITTALS

- A. Product Data: For each type of product.
  - 1. Include construction details, material descriptions, dimensions of individual components and profiles, and finishes for toilet compartments.
- B. Shop Drawings: For toilet compartments.
  - 1. Include plans, elevations, sections, details, and attachment details.
- C. Samples for Verification of Selection:
  - 1. Each type of material, color, and finish required for toilet compartments, prepared on manufacturer's standard-sized square samples of same thickness and material indicated for Work.

#### 1.3 PROJECT CONDITIONS

- A. Field Measurements: Verify actual locations of toilet fixtures, walls, ceilings, and other construction contiguous with toilet compartments by field measurements before fabrication.

### PART 2 - PRODUCTS

#### 2.1 PERFORMANCE REQUIREMENTS

- A. Regulatory Requirements: Comply with applicable provisions in the U.S. Architectural & Transportation Barriers Compliance Board's ADA-ABA Accessibility Guidelines for Buildings and Facilities for toilet compartments designated as accessible.

#### 2.2 MATERIALS

- A. Stainless-Steel Sheet: ASTM A 666, Type 304, stretcher-leveled standard of flatness.
- B. Stainless-Steel Castings: ASTM A 743/A 743M.

## 2.3 SOLID-PLASTIC TOILET COMPARTMENTS

- A. Manufacturer and Products: Subject to compliance with requirements, provide products by one of the following:
  - 1. Accurate Partitions Corporation.
  - 2. Ampco, Inc.
  - 3. Bobrick
  - 4. Bradley Corporation; Mills Partitions.
  - 5. Comtec Industries/Capitol Partitions.
  - 6. General Partitions Mfg. Corp.
  - 7. Global Steel Products Corp.
  - 8. Hadrian Manufacturing Inc.
  - 9. Knickerbocker Partition Corporation.
  - 10. Metpar Corp.
  - 11. Santana Products, Inc.
  - 12. Sanymetal; a Crane Plumbing company.
- B. Toilet-Enclosure Style: Overhead braced.
- C. Door, Panel, Screen, and Pilaster Construction: Solid, high-density polyethylene (HDPE) panel material, not less than 1 inch (25 mm) thick, seamless, with eased edges, and with homogenous color and pattern throughout thickness of material.
  - 1. Heat-Sink Strip: Manufacturer's standard continuous, extruded-aluminum or stainless-steel strip fastened to exposed bottom edges of solid-plastic components to hinder malicious combustion.
  - 2. Color and Pattern: Selected from manufacturer's full range color chart.
    - a. Different colors will be selected for different toilet rooms.
- D. Pilaster Shoes and Sleeves (Caps): ASTM A 666, Type 302 or 304 stainless steel, not less than 0.0312 inch (0.8 mm) thick and 3 inches (75 mm) high, finished to match hardware.
- E. Full-Height (Continuous) Brackets: Manufacturer's standard design for attaching panels and screens to walls and pilasters of the following material:
  - 1. Material: Stainless steel.
- F. Overhead Bracing: Manufacturer's standard continuous, extruded-aluminum head rail with anti-grip profile in manufacturer's standard finish.
- G. Heat-Sink Strip: Manufacturer's standard continuous, extruded-aluminum strip in manufacturer's standard finish.
- H. Anchorages and Fasteners: Manufacturer's standard exposed fasteners of stainless steel, finished to match the items they are securing, with theft-resistant-type heads. Provide sex-type bolts for through-bolt applications. For concealed anchors, use stainless-steel, hot-dip galvanized-steel, or other rust-resistant, protective-coated steel compatible with related materials.
- I. Signage: ADA Universal Accessible sign on door of accessible stall unit.



## 2.4 HARDWARE AND ACCESSORIES

- A. Hardware and Accessories: Manufacturer's standard design, heavy-duty operating hardware and accessories.
  - 1. Material: Stainless steel.
  - 2. Hinges: Manufacturer's standard paired, self-closing type that can be adjusted to hold doors open at any angle up to 90 degrees, allowing emergency access by lifting door.
  - 3. Latch and Keeper: Manufacturer's standard surface-mounted latch unit designed for emergency access and with combination rubber-faced door strike and keeper. Provide units that comply with regulatory requirements for accessibility at compartments designated as accessible.
  - 4. Coat Hook: Manufacturer's standard combination hook and rubber-tipped bumper, sized to prevent in-swinging door from hitting compartment-mounted accessories.
  - 5. Door Bumper: Manufacturer's standard rubber-tipped bumper at out-swinging doors.
  - 6. Door Pull: Manufacturer's standard unit at out-swinging doors that complies with regulatory requirements for accessibility. Provide units on both sides of doors at compartments designated as accessible.

## 2.5 FABRICATION

- A. Fabrication, General: Fabricate toilet compartment components to sizes indicated. Coordinate requirements and provide cutouts for through-partition toilet accessories where required for attachment of toilet accessories.
- B. Overhead-Braced Units: Provide manufacturer's standard corrosion-resistant supports, leveling mechanism, and anchors at pilasters to suit floor conditions. Provide shoes at pilasters to conceal supports and leveling mechanism.
- C. Door Size and Swings: Unless otherwise indicated, provide 28-inch- (710-mm-) wide, in-swinging doors for standard toilet compartments and 36-inch- (914-mm-) wide, out-swinging doors with a minimum 32-inch- (813-mm-) wide, clear opening for compartments designated as accessible.

## PART 3 - EXECUTION

### 3.1 EXAMINATION

- A. Examine areas and conditions, with Installer present, for compliance with requirements for fastening, support, alignment, operating clearances, and other conditions affecting performance of the Work.
  - 1. Confirm location and adequacy of blocking and supports required for installation.
- B. Make corrections to unsatisfactory conditions.

### 3.2 INSTALLATION

- A. General: Comply with manufacturer's written installation instructions. Install units rigid, straight, level, and plumb. Secure units in position with manufacturer's recommended anchoring devices.
  - 1. Maximum Clearances:
    - a. Pilasters and Panels: 1/2 inch (13 mm).
    - b. Panels and Walls: 1 inch (25 mm).
  - 2. Stirrup Brackets: Secure panels to walls and to pilasters with no fewer than three brackets attached at midpoint and near top and bottom of panel.
    - a. Locate wall brackets so holes for wall anchors occur in masonry or tile joints.
    - b. Align brackets at pilasters with brackets at walls.
- B. Overhead-Braced-and-Floor-Anchored Compartments: Secure pilasters to floor and level, plumb, and tighten. Set pilasters with anchors penetrating not less than 1-3/4 inches (44 mm) into structural floor unless otherwise indicated in manufacturer's written instructions. Secure continuous head rail to each pilaster with no fewer than two fasteners. Hang doors to align tops of doors with tops of panels, and adjust so tops of doors are parallel with overhead brace when doors are in closed position.
- C. Screens: Attach with anchoring devices according to manufacturer's written instructions and to suit supporting structure. Set units level and plumb and to resist lateral impact.
- D. Accessories: Mount accessories in accordance with manufacturer's instructions.
- E. ADA signage: Apply Universal Accessible sign at each accessible toilet stall unit.

### 3.3 ADJUSTING

- A. Hardware Adjustment: Adjust and lubricate hardware according to hardware manufacturer's written instructions for proper operation. Set hinges on in-swinging doors to hold doors open approximately 30 degrees from closed position when unlatched. Set hinges on out-swinging doors to return doors to fully closed position.
- B. Provide final protection and maintain conditions that ensure toilet compartments and screens are without damage or deterioration at the time of Substantial Completion.

END OF SECTION 10 21 13

## SECTION 10 28 00 - TOILET ACCESSORIES

### PART 1 - GENERAL

#### 1.1 SUMMARY

- A. Types of toilet and bath accessories required include the following:
  - 1. Mirrors
  - 2. Grab Bars
  - 3. Waste receptacles
  - 4. Under-lavatory piping guards
- B. Owner will furnish, and Contractor shall install, the following:
  - 1. Toilet paper dispensers
  - 2. Paper Towel dispensers
  - 3. Soap dispensers

#### 1.2 SUBMITTALS

- A. Submit manufacturer's product data for each toilet accessory item specified.

#### 1.3 PROJECT CONDITIONS

- A. Coordinate accessory locations, installation, and sequencing with other work to avoid interference with and ensure proper installation, operation, adjustment, cleaning, and servicing of toilet accessory items.

#### 1.4 WARRANTIES

- A. Mirrors: Submit a written warranty executed by mirror manufacturer, agreeing to replace mirrors that develop visible silver spoilage defects within warranty period.
  - 1. Warranty Period: 10 years from date of Substantial Completion.

### PART 2 - PRODUCTS

#### 2.1 MANUFACTURERS

- A. Basis of Design - Specifications below indicate make and model of products by Bobrick; products by other manufacturers' listed below will be acceptable subject to compliance with project requirements.
  - 1. American Accessories, Inc.
  - 2. American Specialties, Inc.
  - 3. Bradley Corporation.
  - 4. General Accessory Manufacturing Co.

#### 2.2 MATERIALS, GENERAL

- A. Stainless Steel: AISI Type 302/304, with polished No. 4 finish, 0.034-inch (22-gage) minimum thickness.

- B. Sheet Steel: Cold-rolled, commercial quality ASTM A 366, 0.04-inch (20-gage) minimum. Surface preparation and metal pretreatment as required for applied finish.
- C. Galvanized Steel Sheet: ASTM A 527, G60.
- D. Chromium Plating: Nickel and chromium electro-deposited on base metal, ASTM B 456, Type SC 2.
- E. Mirror Glass: Nominal 6.0-mm (0.23-inch) thick, conforming to ASTM C 1036, Type I, Class 1, Quality q2, and with silvering, electro-plated copper coating, and protective organic coating.
- F. Galvanized Steel Mounting Devices: ASTM A 153, hot-dip galvanized after fabrication.
- G. Fasteners: Screws, bolts, and other devices of same material as accessory unit, or of galvanized steel where concealed.

### 2.3 MIRROR UNITS

- A. Stainless Steel Framed Mirror Units: 24" x 30" (610 x 762 mm), unless indicated otherwise in the drawings. Mirrors with polished stainless steel frames.
- B. Fabricate frame with angle shapes not less than 0.05 inch (18 gage), with square corners mitered, welded, and ground smooth. No. 4 satin polished finish.
  - 1. Products: B290 series by Bobrick, or equivalent products by manufacturers listed above.

### 2.4 GRAB BARS

- A. Stainless steel, wall thickness not less than 18 gauge (1.25 mm). Concealed mounting with manufacturer's standard flanges and anchorages. Manufacturer's standard non-slip texture for gripping surfaces.
  - 1. Outside diameter of bar 1-1/4 inch (32 mm).
  - 2. Configuration, length and design as indicated in the Drawings. If not indicated, fabricate to comply with ADA requirements for each toilet stall/room and shower situation.
- B. Products: Model B-5806.99 series by Bobrick, or equivalent products by manufacturers listed above.

### 2.5 WASTE RECEPTACLE

- A. Semi-Recessed Waste Receptacle, Wall Mounted: Stainless steel with seamless exposed flange, removable receptacle with seamless exposed walls, hemmed edges, secured by tumbler lockset. 12-gallon capacity.
- B. Products: B3644 by Bobrick, or equivalent products by manufacturers listed above.

### SANITARY NAPKIN DISPOSAL Units

- C. Description: Stainless steel with seamless exposed walls, tightly self-closing top cover with continuous stainless steel piano hinge.

1. Mounting: Surface mounted
2. Capacity: 1.2 gallon
3. Non lockable.

C. Products: B270 by Bobrick, or equivalent products by manufacturers listed above.

## 2.6 UNDERLAVATORY GUARDS

- A. Manufacturers: Subject to compliance with requirements, provide products by one of the following:
1. Plumberex Specialty Products, Inc.
  2. TCI Products.
  3. Truebro, Inc.
- B. Description: Insulating pipe covering for supply and drain piping assemblies, that prevent direct contact with and burns from piping, and allow service access without removing coverings.
1. Material and Finish: Anti-microbial, molded-plastic, white.

## 2.7 FABRICATION

- A. Surface-Mounted Toilet Accessories, General: Except where otherwise indicated, fabricate units with tight seams and joints, exposed edges rolled. Hang doors or access panels with continuous stainless steel piano hinge. Provide concealed anchorage wherever possible.
- B. Framed Mirror Units, General: Fabricate frames for glass mirror units to accommodate wood, felt, plastic, or other glass edge protection material. Provide mirror backing and support system that will permit rigid, tamperproof glass installation and prevent moisture accumulation, as follows:
1. Provide galvanized-steel backing sheet, not less than 0.034 inch (22 gage) and full mirror size, with non-absorptive filler material. Corrugated cardboard is not an acceptable filler material.
- C. Mirror Unit Hangers: Provide system for mounting mirror units that will permit rigid, tamperproof, and theft-proof installation, either one below, as follows:
1. One-piece, galvanized-steel, wall-hanger device with spring-action locking mechanism to hold mirror unit in position with no exposed screws or bolts.
  2. Heavy-duty wall brackets of galvanized steel, equipped with concealed locking devices requiring a special tool to remove.

## 2.8 OWNER FURNISHED UNITS

- A. General: Owner's campus standard units for campus.
- B. Soap Dispensers: Surface wall-mounted unit.
- C. Paper Towel Dispensers: Surface wall-mounted unit.
1. Centerfeed Quartz M2 System 302092 by Tork.

- D. Toilet Tissue Dispensers: Surface wall-mounted jumbo roll toilet tissue dispenser with acrylic cover. Subject to compliance with project requirements, provide one of the following products:
  - 1. Model 9646JRT by Scott Dispenser.
  - 2. FTH580-50 by Roll Tissue Dispenser.

## PART 3 - EXECUTION

### 3.1 PREPARATION AND COORDINATION

- A. Coordinate with related construction to ensure that adequate bracing, blocking, and nailers are provided for securing toilet accessories.
- B. Verify and check the type of construction provided in order to furnish the proper type of fasteners and anchorage devices for securing toilet accessories.

### 3.2 INSTALLATION

- A. Install toilet accessory units according to manufacturers' instructions, using fasteners appropriate to substrate as recommended by unit manufacturer. Install units plumb and level, firmly anchored in locations and at heights indicated.
- B. Secure mirrors to walls in concealed, tamperproof manner with special hangers, toggle bolts, or screws. Set units plumb, level, and square at locations indicated, according to manufacturer's instructions for type of substrate involved.
- C. Install grab bars to withstand a downward load of at least 250 lbf, complying with ASTM F 446.
- D. Install units to comply with ADA required accessibility heights and clearances.

### 3.3 ADJUST AND CLEAN

- A. Adjust toilet accessories for proper operation and verify that mechanisms function smoothly. Replace damaged or defective items.
- B. Clean and polish exposed surfaces strictly according to manufacturer's recommendations after removing temporary labels and protective coatings.

### 3.4 TOILET ACCESSORY SCHEDULE

- A. Contractor provide the following, unless indicated otherwise, locate items as follows:
  - 1. Mirrors: 1 over each lavatory.
  - 2. Grab Bars: 1 set per handicap stall and handicap toilet room.
  - 3. Trash Receptacles: 1 per toilet room.
  - Sanitary Napkin Disposal Units: 1 per toilet stall in Women's/Girls Restroom.
  - 4. Under-lavatory Guards: 1 set for piping under each lavatory.
- B. Owner furnish and Contractor shall install the following:
  - 1. Toilet paper dispensers: One per toilet stall .
  - 2. Paper Towel dispensers: 1 per toilet room.

3. Soap Dispensers: One per lavatory. Mount on wall at location as indicated in drawings, or as directed by Owner or Architect.

END OF SECTION 10 28 00

## SECTION 21 00 00 - FIRE PROTECTION SYSTEM

### PART 1 - GENERAL

#### 1.1 WORK INCLUDED:

- A. The General Conditions of the Contract and Supplementary Conditions of the Contract shall govern the work under this Section of the Specifications. The Contractor is specifically directed to refer to said conditions.
- B. It is understood that these specifications, and the accompanying drawings, complement complete apparatus, fully erected and in successful operating condition. All work must be preformed in the best and most substantial manner.
- C. These specifications are intended to provide complete, and in proper operation, all sprinkler system piping, equipment, heads, valves, controls, air compressor, and accessories, all as specified herein or shown on the accompanying drawings, or reasonably implied in either. The building shall be provided with complete coverage sprinkler system for the spaces designated on the drawings classification as required. System shall consist of a calculated dry system unless indicated otherwise. Verify all pertinent criteria. The systems shall conform to layout shown and meet all requirements of agencies listed under "REGULATIONS AND STANDARDS" below. Refer to plans and specifications for additional information.
- D. Pipe, fittings, valves, and connections for fire protection and sprinkler systems shall be furnished by fire protection contractor.

#### 1.2 RELATED WORK:

- A. Section 21 13 13 - Wet-pipe Sprinkler Systems.

#### 1.3 SYSTEM LAYOUT:

- A. Where plans indicate layout of system components, the layout shall be verified to comply with "REGULATIONS AND STANDARDS" and shall be revised if required to comply. The location of the sprinkler system piping and components shall be coordinated with all other trades. Revisions to sprinkler system layout shall be at Sprinkler Contractor's expense. Any such revisions shall be verified with the Architect.

#### 1.4 ELECTRICAL WORK:

- A. See "COORDINATION".

#### 1.5 SPRINKLER SYSTEM CONTRACTOR:

- A. It is intended that the work under this section is to be preformed by a qualified Fire Protection Piping Systems Contractor regularly engaged in this type of work. The Contractor is to hold a current license to perform this work and be certified by the State Fire Marshall. All documents shall bear this certification.



1.6 REGULATIONS, STANDARDS AND REFERENCES:

- A. It is the intention of these specifications and the accompanying drawings, that all elements and features of the fire protection system shall be in accordance with the standards of the National Fire Association (NFPA), the State Fire Marshall, all applicable building codes and Property Insurance Association of Louisiana whether so indicated or not. NFPA standards are on file in office of Engineer and may be examined at the Contractor's request.
- B. ASME B16.1 - Cast Iron Pipe Flanges and Flanged Fittings, Class 150.
- C. ANSI/ASME B16.3 - Malleable Iron Threaded Fittings, Class 150. Interior of building.
- D. Specifications for Qualification of Welding Procedures and Welders for Piping and Tubing.
- E. NFPA 13 - Installation of Sprinkler Systems.
- F. NFPA 14 - Standpipe and Hose Systems.

1.7 QUALITY ASSURANCE:

- A. Conform to NFPA 13 for sprinkler systems.
- B. Conform to NFPA 14 for standpipe hose systems.
- C. Welding Materials and Procedures: Conform to ASME Code.
- D. Employ certified welders in accordance with ANSI/ASME Section 9. AWS D10.9.
- E. Valves: Bear UL FM label or marking. Provide manufacturer's name and pressure rating marked on valve body.

1.8 SUBMITTALS:

- A. Submit product data under provisions of section 01 30 00 - Administrative Requirements
- B. Indicate pipe materials used, jointing methods, supports, floor and wall penetration seals.
- C. Indicate valve data and ratings.

1.9 DELIVERY, STORAGE, AND HANDLING:

- A. Deliver and store valves in shipping containers, with labeling in place, under provisions of Section 016000– Product Requirements.
- B. Provide temporary protective coating on cast iron and steel valves.
- C. Provide temporary end caps and closures. Maintain in place until installation.

1.10 AREAS SUBJECT TO FREEZING:

- A. For areas requiring protection and not receiving direct heating during times of potential freezing, such as building overhangs, porches, canopies, attics, etc. provide a compressed

air dry pipe system for these areas only, see drawings for locations. Coordinate electrical requirements with contractor.

1.11 MANUFACTURER'S OR TRADE NAMES:

- A. Where the plans or specifications mention the names of manufacturers or the products of specific manufacturers, it is intended that the Contractor shall furnish the item or items as specifies. Products of manufacturers that are not mentioned shall be subject to prior review by the Engineer and shall in any case mentioned shall be subject to prior review by the Engineer and shall in any case be in accordance with regulations and standards as state above.

1.12 SHOP DRAWINGS AND SUBMITTAL DATA:

- A. Within fifteen (15) days of award of the contract, the contractor shall submit six (6) copies of system piping shop drawings and six (6) copies of manufacturer's data and descriptive literature and drawings for all equipment and materials. Additionally, provide a reproducible (sepia) copy of the system piping shop drawings. All drawings, literature and data on all equipment shall be submitted at the same time; this material shall contain complete layout, capacity data, dimensions and other pertinent information necessary for the Architect to properly review and evaluate the item that necessary to meet the requirements for submittal to the State Fire Marshall.
- B. The contractor shall obtain approval of agencies listed under "REGULATIONS AND STANDARDS" before submitting to the Engineer, except that the date for State Fire Marshall's review shall be submitted to the Engineer prior submitting to the Fire Marshall. All required review fees and applicable requirements shall be by the contractor. No item of equipment or material shall be place on order until Final Review comments have been received from the Architect. See "DRAWINGS" below.

1.13 ORDINANCES, RULES AND REGULATIONS:

- A. All material and construction shall conform to the requirements of all building, plumbing and sanitary codes and laws in force in the locality in which the work is to be done. All materials and construction shall also conform to the rules and regulations listed above under "REGULATIONS AND STANDARDS".

1.14 DRAWINGS:

- A. The contractor shall submit detailed drawings for all sprinkler system showing exact locations and sizes of all elements in the system before fabrication is begun. Engineer shall have the prerogative of changing the position or configuration of these systems without changing the total scope of work involved to comply with "REGULATIONS AND STANDARDS".

1.15 GUARANTEE:

- A. The contractor shall guarantee all materials and workmanship under this contract for a period of one (1) year from date of final acceptance of his work and shall repair or replace any such defective materials and workmanship without cost to the Owner.

- B. The guarantee shall include complete service, including adjustment service and inspection, during the guarantee period as required by agencies listed under "REGULATIONS AND STANDARDS".

#### 1.16 APPROVAL OF PRODUCT PRIOR TO BIDDING

- A. Refer to Instructions to Bidders

### PART 2 - PRODUCTS

#### 2.1 PIPE AND TUBE:

- A. See Section – 21 13 13 Wet-pipe Sprinkler System
- B. Underground pipe shall be C900 to within 5' of building.

#### 2.2 PIPE FITTINGS:

- A. Steel Fittings: ANSI/ASME B16.9, wrought steel, butt welded. ANSI/ASME B16.25, butt weld ends. ASTM A234, wrought carbon steel and alloy steel. ANSI/ASME B16.5, steel flanges and fittings. ANSI/ASME B16.11, forged steel socket welded and threaded.
- B. Cast Iron Fittings: ANSI/ASME B16.1, flanges and fittings. B16.4, screwed fittings.
- C. Malleable Iron Fittings: ANSI/ASME B16.3, screwed type. ANSI/ASTM A47.

#### 2.3 JOINT MATERIALS:

- A. Solder: ANSI/ASTM B32, 95/5 alloy.
- B. Brazing: ANSI/AWS A5.8.
- C. Threaded Joint Compound.

#### 2.4 UNIONS, FLANGES, AND COUPLINGS:

- A. Unions: 150 psi malleable iron for threaded ferrous piping.
- B. Flanges: 150 psi forged steel slip-on flanges for ferrous piping.

#### 2.5 ACCEPTABLE MANUFACTURER - GATE VALVES:

- A. Nibco 637-31
- B. Central 722 U Series
- C. Substitutions: Under provisions of Instructions To Bidders.

#### 2.6 GATE VALVES:

- A. Bronze, rising stem, inside screw, solid wedge.

2.7 ACCEPTABLE MANUFACTURERS - GLOBE OR ANGLE VALVES:

- A. Nibco GS-132-U
- B. Crane 143
- C. Substitutions: Under provisions of Instructions To Bidders.

2.8 GLOBE OR ANGLE VALVES:

- A. Bronze, rising stem, inside screw, renewable composition disc.

2.9 ACCEPTABLE MANUFACTURERS - CHECK VALVES:

- A. NIBCO CS-172
- B. Crane 147
- C. Substitutions: Under provisions of Instructions To Bidders.

2.10 CHECK VALVES:

- A. Iron body, bronze trim, swing disc, renewable disc and seat.

2.11 ACCEPTABLE MANUFACTURERS - BUTTERFLY VALVES:

- A. Nibco LD 3510-2 Series
- B. Central Fig. 570 or 580
- C. Substitutions: Under provisions of Instructions To Bidders.

2.12 BUTTERFLY VALVES:

- A. Iron body, bronze stainless steel disc and stem extended for insulated work, resilient replaceable liner seat.

2.13 ACCEPTABLE MANUFACTURERS - DRAIN VALVES:

- A. Nibco F-667-0 Series
- B. Central 722 U Series
- C. Substitutions: Under provisions of Instructions To Bidders.

2.14 DRAIN VALVES:

- A. Brass ball valve with cap and chain, 3/4 inch (19 mm) hose thread.

2.15 VALVE OPERATORS:

- A. Provide handwheels for gate, globe or angle, and drain valves.

- B. For butterfly valves provide gear operators for sizes 8 inches and larger. For smaller sizes provide level lock handle with toothed plate.

2.16 VALVE CONNECTIONS:

- A. Provide valve connections to match pipe joints. Use valves of pipe size.
- B. For copper tube, provide threaded solder adapters for connection to valve.
- C. Provide butterfly valve with tapped lug body when used for isolating service.

2.17 SIAMESE FIRE DEPARTMENT CONNECTIONS:

- A. Provide two-way standard siamese fire department connection with chrome plated finish, local fire department threads, dust caps and chains, 3/4" automatic drip, marked "SPRINKLER - FIRE DEPARTMENT CONNECTION:..

2.18 ACCEPTABLE MANUFACTURERS - SPRINKLER HEADS:

- A. Reliable Automatic Sprinkler
- B. Viking Corp.
- C. Tyco-Fire
- D. Substitutions: Under provisions of Instruction To Bidders.

PART 3 - INSTALLATION

3.1 GENERAL:

- A. Furnish and install in a neat workmanlike manner, all piping shown on drawings or that is specified or required to provide a complete, properly operating installation. All piping and accessories shall conform to standards as applicable.
- B. Run piping parallel with the lines of the building, unless specifically shown or noted otherwise. All pipe, fittings, valves, etc., shall have sufficient clearance from other work to finish at least 1/2 inch from other work or finished covering of other piping.
- C. Provide all necessary hangers, anchors, thrust blocks, etc., to properly support and protect piping system, as required by agencies listed under "REGULATIONS AND STANDARDS".
- D. Under no circumstances is the contractor to attach to or support from any bar joist bridging. Any supports to the bar joists or any structural systems are to be approved by the Architect/Engineer. All supplement angle or channel iron required to support equipment of this Specification is to be furnished by the contractor and is to be independent of any other supports.

3.2 DESIGN:

- A. The sprinkler systems shall be designed as required for occupancies specified by

experienced personnel have competency in the execution of such work. Sprinkler system design shall be performed only by licensed sprinkler contractors.

- B. Sprinkler piping shall be protected from freezing during the lay-a-way period.
- C. NFPA rules and regulations governing the design shall be scrupulously adhered to.
- D. Piping shall be installed in accordance with NFPA 13.

### 3.3 EXECUTION:

- A. Run piping concealed above furred ceiling and in joists to minimize obstructions. Expose only heads.
- B. Coordinate sprinkler piping routing and heads with all trades.
- C. Protect sprinkler heads against mechanical injury.
- D. Include all costs of shop drawings review and approval from authorities in price.
- E. Locate outside alarm on wall of building adjacent to Siamese department connections.
- F. Provide cabinet containing required number of spare heads as per NFPA 13, of each type, along with wrench suitable for each type of head.
- G. Provide flow switch on leaving side of main valve and monitoring switch on main valve. Flow switch shall sense flow and sound appropriate zone of fire alarm system monitoring switch on each main valve; when valve is started to its "closed" position shall indicate trouble on appropriate zone of fire alarm system and sound local audible alarm. Wiring between flow switches and monitoring switches and fire alarm system shall be provided under the Electrical Division.
- H. Furnish and install sprinkler zone valves and flow switches where indicated on the drawings for the zoning of the system. Each of these devices shall be connected into the fire alarm system as indicated for the main valve, including local alarming.
- I. Provide all test and drain valves as required per NFPA 13.
- J. Support sprinkler piping in accordance with NFPA 13.
- K. Provide new water service as shown on the drawings.
- L. Install air compressor on vibration isolators, as required.
- M. Screw joint steel piping up to and including 1-1/2 inch diameter. Screw or Roll Goove 2 inch diameter and larger. PER NFPA 13.
- N. Die cut screw joints with full cut standard taper pipe threads with red lead and linseed oil or other non-toxic joint compound applied to male threads only.
- O. Coat threaded ends with pipe lubricant compound.

- P. Steel piping, main sized saddle branch connections or direct connection of branch lines to mains is permitted if main is one pipe size larger than the branch for up to 6 inch mains and if main is two pipe sizes larger than branch for 8 inch and larger mains.
  - Q. Solder Braze copper tubes.
  - R. Install piping in accordance with NFPA 13 for sprinkler systems and NFPA 14 for standpipe and hose systems.
  - S. Do not penetrate building structural members unless indicated.
  - T. Provide sleeves when penetrating footings floors and walls.
  - U. Seal pipe and sleeve penetration to achieve fire resistance equivalent to fire separation required.
- 3.4 INSTALLATION - VALVES:
- A. Install valves with stems upright or horizontal, not inverted.
  - B. Provide gate valves for shut-off or isolating service.
  - C. Where approved, butterfly valves may be used instead of gate valves.
  - D. Provide drain valves at main shut-off valves, low points of piping and apparatus.
- 3.5 SLEEVES AND PLATES:
- A. Wherever pipes pass through concrete slabs, furnish and install sleeves, properly located for the work.
  - B. Use sleeves of sufficient size to allow the specified pipe covering to pass through the sleeves and finish sleeves flush with walls and ceiling.
  - C. Sleeves shall be galvanized steel not lighter than 24 gauge.
  - D. Seal spaces between sleeve and pipe. Use packing device or material for UL rating to match rating of wall or floor/ceiling as rated under UL File R9658.
- 3.6 ESCUTCHEONS:
- A. Where pipes passing through floors, walls or ceiling exposed to view in finished areas, provide pressed steel split plates which cover the opening and fit snugly to pipe.
- 3.7 COORDINATION:
- A. All interlock and signal wiring runs to the annunciator panel will be furnished and installed and as part of the Electrical Work.
  - B. This contractor shall provide for all switches and interlocking devices on all valves as required.

3.8 UNDERGROUND PIPING:

- A. Underground fire protection system piping shall be installed in accordance with the requirements of NFPA 24, Private Fire Service Mains and Their Appurtenances. Provide concrete thrust blocking at each change of direction of the piping and at all tees, plugs, and caps in accordance with NFPA 24. Where thrust blocking is impractical, fittings with a mechanical joint retainer gland, approved for the piping material utilized, may be used in lieu of thrust blocking.

END OF SECTION 21 00 00



## SECTION 21 13 13 - WET-PIPE SPRINKLER SYSTEMS

### PART 1 - GENERAL

#### 1.1 WORK INCLUDED

- A. Revision of existing sprinkler piping & head location for renovated building areas.

#### 1.2 WORK INSTALLED BUT SPECIFIED UNDER OTHER SECTIONS

- A. Section Fire Protection Piping: Piping and valves.

#### 1.3 WORK FURNISHED BUT INSTALLED UNDER OTHER SECTIONS

- A. Furnish sleeves to General Contractor.

#### 1.4 RELATED WORK

- A. Section 23 05 29 - Supports and Anchors.

#### 1.5 REFERENCES:

- A. NEMA 250 - Enclosures for Electrical Equipment (1000 Volt maximum).
- B. NFPA 13 - Installation of Sprinkler Systems.

#### 1.6 SYSTEM DESCRIPTION:

- A. System to provide coverage for entire new building area.
- B. Interface system with building control system. Building fire and smoke alarm system.
- C. Provide system per NFPA 13 hazard requirement.

#### 1.7 QUALITY ASSURANCE:

- A. Design and installation to conform to NFPA 13.
- B. Equipment and components: Bear UL FM label or marking.
- C. Specialist Firm: Company specializing and licensed in sprinkler systems.

#### 1.8 REGULATORY REQUIREMENTS:

- A. Hydraulic Calculations, Product Data, Shop Drawings: Bear stamp of approval of Fire Marshal.
- B. Indicate hydraulic calculations, detailed pipe layout, hangers and supports, components and accessories.
- C. Submit shop drawings product data hydraulic calculations to Fire Marshal. Submit proof of

approval to Architect. Include check for review fee with submittal to Fire Marshal's office.

1.9 PROJECT RECORD DOCUMENTS:

- A. Submit documents under provisions of Section 01 78 39.

1.10 OPERATION AND MAINTENANCE DATA:

- A. Submit manufacturer's operation and maintenance data under provisions of Section 01 78 23.
- B. Include written maintenance data on components of system, servicing requirements, and record drawings.
- C. Include maintenance, inspection data, replacement part numbers and availability, and location and numbers of service depot.

1.11 DELIVERY, STORAGE, AND HANDLING:

- A. Deliver and store materials in shipping containers with labeling place under provisions of Section 01 60 00.
- B. Provide suitable wrenches for each head type.
- C. Maintain caps in place until installation.

1.12 EXTRA STOCK:

- A. Provide extra sprinkler heads under provisions of NFPA 13.
- B. Provide suitable wrenches for each head type.
- C. Provide storage cabinet, size and type as per NFPA-13

PART 2 - PRODUCTS

2.1 PIPING MATERIALS:

- A. Above Ground Inside Building Piping: Pipe diameter smaller than and up to 2" shall be Steel Schedule 40 pipe, Pipe diameters 2-1/2" and larger shall be Steel Schedule 10 or Steel Schedule 40 pipe, As permitted by NFPA 13.

2.2 ACCEPTABLE MANUFACTURERS - SPRINKLER HEADS:

- A. Reliable Automatic Sprinkler
- B. Viking Corp.
- C. Tyco-Fire
- D. Substitutions: Under provisions of Instruction To Bidders.

## 2.3 SPRINKLER HEADS:

- A. Exposed Area Type: Standard upright type with brass finish.
- B. Sidewall Type: Brass Chrome plated finish with matching escutcheon.
- C. Fusible Link: Temperature rated for specific area hazard.
- D. Guards: finish to match sprinkler head.
- E. Finished ceilings: Pendent sprinklers - concealed type with white cover plates. Unless otherwise noted on plans.

## PART 3 - EXECUTION

### 3.1 PREPARATION:

- A. Place pipe runs to minimize obstruction to other work.

### 3.2 INSTALLATION:

- A. Run piping concealed above furred ceiling and in joists to minimize obstructions. Expose only heads.
- B. Coordinate sprinkler piping routing and heads with all trades.
- C. Protect sprinkler heads against mechanical injury.
- D. Include all costs of shop drawings review and approval from authorities in price.
- E. Locate outside alarm on wall of building adjacent to siamese fire department connections.
- F. Provide cabinet containing required number of spare heads as per NFPA 13, of each type, along with wrench suitable for each type of head.
- G. Provide flow switch on leaving side of main valve and monitoring switch on main valve. Flow switch shall sense flow and sound appropriate zone of fire alarm system monitoring switch on each main valve; when valve is started to its "closed" position shall indicate trouble on appropriate zone of fire alarm system and sound local audible alarm. Wiring between flow switches and monitoring switches and fire alarm system shall be provided under electrical division.
- H. Furnish and install sprinkler zone valves and flow switches where indicated on the drawings for the zoning of the system. Each of these devices shall be connected into the fire alarm system as indicated for the main valve, including local alarming.
- I. Provide all test and drain valves as required for system per NFPA 13.
- J. Support sprinkler piping in accordance with NFPA 13.
- K. Provide new water service as shown on the drawings.

3.3 CLEANING:

- A. Flush entire piping system of foreign matter.

3.4 SYSTEM TESTS:

- A. Hydrostatically test entire system.
- B. Test shall be witnessed by Fire Marshal and Architect.

END OF SECTION 21 13 13

## SECTION 22 10 00 - PLUMBING PIPING

### PART 1 - GENERAL

#### 1.1 WORK INCLUDED

- A. Pipe and Pipe Fittings
- B. Valves
- C. Sanitary Sewer Piping System
- D. Domestic Water Piping system
- E. Service Connections
- F. Natural Gas Piping System

#### 1.2 RELATED WORK

- A. Section 23 00 00 - General Mechanical
- B. Section 23 05 29 - Supports and Anchors
- C. Section 23 07 00 - Piping and Equipment Insulation
- D. Section 22 10 10 - Plumbing Specialties
- E. Section 22 40 00 - Plumbing Fixtures and Trim

#### 1.3 REFERENCES:

- A. ANSI/ASME B16.3 - Malleable Iron Threaded Fittings Class 150 NS 300.
- B. ANSI/ASME B16.23 - Cast Copper Alloy Solder Joint Drainage Fittings - DWV.
- C. ANSI/ASME B16.29 - Wrought Copper and Wrought Copper Alloy Solder Joint Drainage Fittings - DWV.
- D. ANSI/ASME Sec. 9 - Welding and Brazing Qualifications.
- E. ANSI/ASTM B32 - Solder Metal.
- F. ANSI/ASTM C443 - Joints for Circular Concrete Sewer and Culvert Pipe, Using Rubber Gaskets.
- G. ASTM A53 - Pipe, Steel, Black and Hot-Dipped Zinc Coated, Welded and Seamless.
- H. ASTM A74 - Cast Iron Soil Pipe and Fittings.
- I. ASTM A234 - Pipe Fittings of Wrought Carbon Steel and Alloy Steel for Moderate and

Elevated Temperatures.

- J. ASTM B88 - Seamless Copper Water Tube.
  - K. ASTM B306 - Copper Drainage Tube (DWV).
  - L. ASTM C564 - Rubber Gaskets for Cast Iron Soil Pipe and Fittings.
  - M. AWS A5.8 - Brazing Filler Metal.
  - N. AWWA C601 - Standard Methods for the Examination of Water and Waste Water.
  - O. CISPI 301 - Cast Iron Soil Pipe and Fittings for Hubless Cast Iron Sanitary System.
  - P. CISPI 310 – Standard for cast iron couplings
  - Q. LSPC – The latest addition of the Louisiana State Plumbing Code.
- 1.4 QUALITY ASSURANCE:
- A. Valves: Manufacturer's name and pressure rating marked on valve body.
  - B. Welding Materials and Procedures: Conform to ASME Code and applicable state labor regulations.
  - C. Welders Certification: In accordance with ANSI/ASME Sec. 9. ANSI/AWS D 1.1.
  - D. Cast iron pipe and fittings shall be marked with CISPI's collective trademark.
- 1.5 SUBMITTALS:
- A. Submit shop drawings and product data under provisions of Section 01 30 00.
  - B. Include data on pipe material, pipe fittings, valves and accessories.
- 1.6 WATER PIPE AND FITTING MATERIALS STANDARD
- A. Plastic Water Pipe and Fittings
    1. ABS and PVC Plastic Tubular Fittings: ASTM F 409, ANSI/NSF 24, ANSI/NSF 14
    2. Joints for IPS PVC pipe using solvent cement: ASTM D 2672
    3. Chlorinated poly (vinyl chloride) (CPVC) plastic pipe, Schedule 80, 2" and under: ASTM F 441, listed
    4. Chlorinated poly (vinyl chloride) (CPVC) plastic pipe (SDR-PR): ASTM F 442
    5. CPVC Pipe and fittings: ASTM D 2846, Listed
    6. Cross-linked Polyethylene/Aluminum/Cross-linked Polyethylene (PEX-AL-PEX) pressure pipe and fittings: ASTM F 1281
    7. Cross-linked Polyethylene (PEX) plastic hot and cold water distribution system: ASTM F 877, Listed
    8. Cross-linked Polyethylene (PEX) tubing: ASTM F 876
    9. Cross-linked Polyethylene (PEX) tubing systems for pressure: CAN/CSA-B137.5M89, listed
    10. Flexible Elastomeric pressure joints: ASTM D 3139, See 308.8

11. Metal insert fittings for PB tubing: ASTM F 1380
  12. Polyethylene/Aluminum/Polyethylene (PE-AL-PE) pressure pipe and fittings: ASTM F 1282
  13. Polyethylene pipe and tubing (PE) Number 2305, 2306, 3306, 3406, 3408: ASTM D 2104, ASTM D 2239, ASTM D 2737, Listed, See 303.8.2
  14. Poly (vinyl chloride) (PVC) plastic pipe fittings, Schedule 40: ASTM D 2466
  15. Pressure rated ABS-fittings: ASTM D 2468, Listed
  16. Pressure rated ABS-pipe Number 1210, 2112, 1316: ASTM D 1527, ASTM D 2282, Listed, See 303.8.2
  17. PVC injection molded gasketed fittings for pressure applications: CAN/CSA-B137.2-M89, Listed
  18. PVC Pipe, Number 1120, 1220: ASTM D 1785, ASTM D 2241, listed, See 303.8.2
  19. PVC socket-type fittings, Schedule 80: ASTM D 2467, listed
  20. Socket-type chlorinated poly (vinyl chloride) (CPVC) plastic pipe fittings, Schedule 80, 2" and under: ASTM F 439, listed
  21. Threaded chlorinated poly (vinyl chloride) (CPVC) plastic pipe fittings, Schedule 80, 2" and under: ASTM F 437, listed
- B. Ferrous Water Pipe and Fittings
1. Cast Iron fittings (threaded): ASTM A 126
  2. Cast iron pipe (threaded): ANSI A40.5
  3. Cast iron water pipe: ASTM A377
  4. Ductile-iron water pipe: ANSI/AWWA C 151/A 21.51
  5. Ductile-iron water fittings: ANSI/AWWA C 110/A 21.10
  6. Malleable iron fittings (threaded): ASTM A 197
  7. Nipples pipe (threaded): FS WW-N-351a
  8. Stainless steel water pipe Grade H: ASTM A 268, See 303.8.4
  9. Steel couplings, threaded, black and galvanized: ASTM A 865
  10. Steel pipe black and galvanized: ASTM A 53
  11. Welded and seamless steel pipe: ASTM A 53
- C. NonFerrous Pipe and Fittings
1. Cast bronze fittings for flared copper tube: ANSI B16.26
  2. Cast bronze threaded fittings: ASME B16.15
  3. Cast bronze solder-joint pressure fittings: ANSI B16.18
  4. Cast copper alloy fittings for flared copper tubes: ASME B 16.26
  5. Pipe flanges and flanged fittings: ANSI B16.5
  6. Seamless brass tube: ASTM B 135
  7. Seamless copper pipe: ASTM B 42
  8. Seamless copper tube: ASTM B 75
  9. Seamless copper water tube types K, L, & M: ASTM B 88
  10. Seamless red brass pipe: ASTM B 43
  11. Seamless and welded copper distribution tube (type D): ASTM B 641
  12. Threadless copper pipe (TP): ASTM B 302
  13. Welded brass tube: ASTM B 587
  14. Welded copper tube: ASTM B 447
  15. Welded copper alloy UNS # C21000 water tube: ASTM B 642
  16. Wrought copper and copper-alloy solder-joint pressure fittings: ASME B 16.22 for copper water tube
  17. Wrought seamless copper and rectangular copper-alloy pipe and tube: ASTM B 251, square and tubing not applicable

18. Valves-flanged threaded, and welding end: ANSI B 16.34
- D. Backflow Prevention Devices Materials Standard
1. Air gap standards: ASME A112.1.2
  2. Backflow preventers, double check valve assembly: ASSE 1015, ANSI/AWWA C510
  3. Backflow preventers with intermediate atmospheric vent: ANSI/ASSE 1012
  4. Backflow preventers, double check detector assembly: ANSI/ASSE 1048
  5. Backflow preventers, hose connection: ANSI/ASSE 1052
  6. Backflow preventers, reduced pressure detector assembly: ANSI/ASSE 1047
  7. Backflow preventers, reduced pressure principle assembly: ANSI/AWWA C511, ASSE 1013
  8. Dual check valve type backflow preventer: ASSE 1032, for carbonated beverage dispensers-post mix type
  9. Field test procedures for backflow preventer assemblies: ASSE 5010
  10. Manual for the selection, installation, maintenance, and field testing of backflow prevention devices: CAN/CSA B64.10
  11. Vacuum breakers, Anti-Siphon, pressure type assembly (outdoor use): ASSE 1020
  12. Vacuum breakers-atmospheric pipe applied: ANSI/ASSE 1001
  13. Vacuum breakers, back siphonage, pressure type assembly (spill resistant): ANSI/ASSE 1056
  14. Vacuum breakers, hose connections: ANSI/ASSE 1011
  15. Vacuum breakers, laboratory faucet: ANSI/ASSE 1035
  16. Vacuum breaker wall hydrants, fronts resistant automatic draining: ASSE 1019
  17. Water closet flush tank fill valves (ballcocks): ASSE 1002
- E. Valves Material Standards
1. Valves, bronze gate: MSS SP-80
  2. Valves, cast iron gate: ASTM A 126
  3. Valves, ball: MSS SP-72, MSS SP-110
  4. Valves, resilient-seated gate: ANSI/AWWA C509
- F. Temperature Control Device Standards
1. Individual shower control valves, anti-scald: ASSE 1016
  2. Temperature actuated mixing valves for primary domestic use: ASSE 1017
  3. Water supply valves, mixing valves and single control mixing valves: ASSE 1029
- G. Potable Water Piping
1. All potable water pipes, pipe related products, and materials that join or seal pipes conform to ANSI/NSF 61.
- 1.7 DRAINAGE SYSTEM MATERIALS STANDARDS
- A. NonMetallic Piping
1. Concrete drain tile: ASTM C 412
  2. Concrete perforated: ASTM C 444
  3. Concrete reinforced culverts: ASTM C 76, for storm drains only
  4. Concrete reinforced sewer pipe: ASTM C 361, for storm drains only
  5. Concrete sewer pipe: ASTM C 14, for storm drains only
  6. Sewer manholes: ASTM C 478
  7. Concrete (steel cylinder type): FS SS-P-381



- B. Plastic Pipe and Fittings
  - 1. Coextruded composite pipe: ASTM F 1488, See 303.8.3, 303.8.5, 704.1, 1101.5, 1103.2, 1103.4
  - 2. Coextruded composite drain, waste, and vent pipe (DWV): ASTM F 1499, See 303.8.3, 303.8.5, 704.1, 1101.5, 1103.2, 1103.4
  - 3. Coextruded PVC plastic pipe: ASTM F 891, See 303.8.3, 303.8.5, 704.1, 1101.5, 1103.2, 1103.4
  - 4. Flexible elastomeric non-pressure joints: ASTM D 3212, See 303.8
  - 5. Large diameter ribbed PVC sewer pipe and fittings: CAN/CSA-B182.4
  - 6. Polyolefin laboratory drainage systems: CAN/CSA-B181.3
  - 7. PVC-DWV pipe and fittings: ASTM D 2665, listed, See 303.8.3
  - 8. Type PS 46 and type PS 115 sewer pipe (for outside building sewers, storm drains): ASTM F 789, See 704.1, 1101.4, 1103.2, 1103.4, ASTM D 2321, installation
  - 9. Type PSM PVC sewer pipe and fittings (for outside building sewers, storm drains, and storm sewers): ASTM 3034, See 704.1, 1101.5, 1103.2, 1103.4, ASTM D 2321, installation
  - 10. Type PSP PVC sewer pipe and fittings (for outside building sewers, storm drains, and storm sewers): ASTM D 2321, Installation
  - 11. All plastic piping pipes, plastic plumbing piping components and related materials shall be listed as conforming with ANSI/NSF Standard 14.
  
- C. Ferrous Pipe and Fittings
  - 1. Cast iron soil pipe and fittings: ASTM A 74, CISPI HS
  - 2. CI NO-HUB pipe and fittings: ASTM A 888, CISPI Std. 301
  - 3. Ductile-iron gravity sewer pipe: ASTM A 746
  - 4. Hubless cast iron sanitary system: CISPI Std. 310
  - 5. Manhole top frames and covers: ASTM A 48
  
- D. NonFerrous Pipe and Fittings
  - 1. Cast copper alloy solder-joint drainage fittings: ASME B 16.23, for plumbing drainage waste and vents
  - 2. Cast copper alloy solder-joint fittings for solvent drainage systems: ANSI B 16.32
  - 3. Copper drainage tube DWV: ASTM B 306
  - 4. Welded copper and copper alloy heat exchanger tube: ASTM B 543
  - 5. Wrought copper and wrought copper alloy solder-joint drainage fittings for plumbing drainage waste and vents: ASME B 16.29
  - 6. Wrought copper and wrought copper alloy solder-joint fittings for solvent drainage systems: ANSI B 16.43
  
- E. Glass pipe
  - 1. Borosilicate glass pipe and fittings for DWV applications: ASTM C 1053

## PART 2 - PRODUCTS

### 2.1 SANITARY SEWER PIPING - BURIED BEYOND 5 FEET OF BUILDING:

- A. Schedule 40 PVC/DWV  
Fittings: Same as piping  
Joints: Solvent welded

- 2.2 SANITARY SEWER PIPING - BURIED WITHIN 5 FEET OF BUILDING:
- A. Schedule 40 PVC/DWV  
Fittings: Same as piping  
Joints: Solvent welded
- 2.3 SANITARY SEWER PIPING, ABOVE GRADE:
- A. Schedule 40 PVC/DWV  
Fittings: Same as piping  
Joints: Solvent welded
- 2.4 WATER PIPING, ABOVE GRADE: Exterior water piping buried beyond 5' of building to be schedule 40 pvc.
- A. Copper Tubing: ASTM B88, Type L, hard drawn.  
Fittings: ANSI/ASME B16.18, cast bronze solder-joint pressure fittings, or ANSI/ASME B16.22, wrought copper.
  - B. PVC schedule 40 Pipe: ASTM D 1785  
PVC schedule 40 fittings: ASTM 2466 socket type.
  - C. All potable water pipes, pipe related products and materials that join or seal pipes and pipe related products shall be evaluated and listed as conforming with a national consensus product or material standard and ANSI/NSF Standard 61.
- 2.5 WATER PIPING, TRAP PRIMERS: Piping for trap primer piping below slab only.
- A. Soft Copper Tube: ASTM B 88, Types K and L, water tube, annealed temper.
- 2.6 NATURAL GAS PIPING, BURIED BEYOND 5 FEET OF BUILDING:
- A. Polyethylene Pipe: ASTM D2513, SDR 11.5.  
Fittings: ASTM D2683 to ASTM D2513, socket type.  
Joints: Fusion welded.
- 2.7 NATURAL GAS PIPING, ABOVE GRADE:
- A. Steel Pipe: ASTM A53 or A120, Schedule 40, black.  
Fittings: ANSI/ASME B16.3, malleable iron, or ASTM A234, forged steel welding type.  
Joints: Screwed for pipe two (2) inches and under; ANSI/AWS D1.1 welded, for pipe over two (2) inches. All gas piping run in a concealed space shall be welded.
- 2.8 FLANGES, UNION, AND COUPLINGS:
- A. Pipe Size two (2) Inches and Under: 150 psig malleable iron unions for threaded ferrous piping; bronze unions for copper pipe, solder joints.
  - B. Pipe Size Over two (2) Inches: 150 psig forged steel slip-on flanges for ferrous piping; bronze flanges for copper piping; neoprene gaskets for gas service.
  - C. Dielectric Connections: Unions with galvanized or plated steel threaded end, copper solder

end, water impervious isolation barrier.

## 2.9 GATE VALVES

- A. Up to two (2) Inches: Bronze body, non-rising or rising stem and handwheel, inside screw, single double wedge or disc, solder or threaded ends. Nibco Model 113 Series, Crane Model 438 Series, Powell Model 2700, Hammond 2B 617 or approved equal.
- B. Over two (2) Inches: Iron body, bronze trim, non-rising or rising stem and handwheel, OS&Y, single wedge, flanged ends. Red and White 415/421, NIBCO F619/F617, Crane 461/465 1/2 or approved equal.

## 2.10 GLOBE VALVES:

- A. Up to 2 Inches: Bronze body, rising stem and handwheel inside screw, renewable composition disc, solder screwed ends, with backseating capacity. Nibco Model 211 Series, Crane Model 1 Series, Powell Model 150, Hammond 1.413, Red White 211/212 or approved equal.
- B. Over 2 Inches: Iron body, bronze trim, rising stem and handwheel, OS&Y, plug-type disc, flanged ends. Red and White Fig 400 or NIBCO F718-B, Crane 351 or approved equal.

## 2.11 BALL VALVES:

- A. Up to 2 Inches: Bronze or stainless steel body, stainless steel ball, teflon seats and stuffing box ring, lever handle and balancing stops, solder threaded ends with union. Nibco Model 580 Series, Crane Model 2330 Series, Red White 5092/5095 or approved equal.
- B. Over 2 inches: Cast steel body, chrome plated steel ball teflon seat and stuffing box seals, lever handle or gear drive handwheel for sizes 10 inches and over, flanged.

## 2.12 BUTTERFLY VALVES:

- A. Iron body, bronze disc, resilient replaceable seat for service to 180-degrees F, or lug end butterfly, 10 position over handle or infinite position lever handle with memory stop.

## 2.13 SWING CHECK VALVES:

- A. Up to 2 inches: Bronze 45 degree swing disc, solder or screwed ends. Nibco Model 413 Series, Crane Model 37 Series, Red White 236/237 or approved equal.
- B. Over 2 inches: Iron body, bronze trim, 45 degrees swing disc, renewable disc and seat, flanged ends. Red White 435, Nibco F918, Crane 373 or approved equal.

## 2.14 SPRING LOADED CHECK VALVES:

- A. Iron body, bronze trim, spring loaded, bronze disc, wafer.
- B. Red White 442, Nibco W920W, Stockham W6-970 or approved equal.

## PART 3 - EXECUTION

### 3.1 PREPARATION:

- A. Ream pipe and tube ends. Remove burrs. Bevel end Ferrous pipe.
- B. Remove scale and dirt, on inside and outside, before assembly.
- C. Prepare piping connections to equipment with flanges or unions.

### 3.2 INSTALLATIONS:

- A. Provide non-conducting dielectric connections wherever jointing dissimilar metals.
- B. Route piping in orderly manner and maintain gradient.
- C. Install piping to conserve building space and not interfere with use of space.
- D. Group piping whenever practical at common elevations.
- E. Install piping to allow for expansion and contraction without stressing pipe, joints, or connected equipment.
- F. Provide clearance for installation of insulation and access to valves and fittings.
- G. Provide access where valves and fittings are not exposed.
- H. Slope water piping and arrange to drain at low points.
- I. Establish elevations of buried piping outside the building to insure not less than 3 feet of cover.
- J. Where pipe support members are welded to structural building framing, scrape, brush clean, and apply one coat of zinc rich primer to welding.
- K. Prepare pipe, fittings, supports, and accessories not prefinished, ready for finish painting.
- L. Establish invert elevations, slope all drainage piping 4 inches and larger to 1/8 inch per foot minimum. All drainage piping 3 inches and smaller shall be sloped to 1/4 inch per foot minimum.
- M. Install bell and spigot pipe with bell end upstream.
- N. Install valves with stems upright or horizontal, not inverted.
- O. Provide one plug cock wrench for every ten plug cocks sized 2 inches and smaller, minimum of one. Provide one plug cock wrench for each plug cock sized 2-1/2 inches and larger.
- P. In pipe 3 – inch nominal diameter or less, cleanouts shall be located at not more than 50ft.intervals
- Q. In pipe 4 – inches nominal diameter through 6 inches nominal diameter, cleanouts shall be located at not more than 80ft. intervals

- R. Each building drain shall be provided with a cleanout within 6ft. of the junction of the building drain and building sewer.

### 3.3 APPLICATION:

- A. Grooved mechanical couplings and fasteners not allowed.
- B. Install unions downstream of valves and at equipment or apparatus connections.
- C. Install brass male adapters each side of valves in copper piped system. Sweat solder adapters to pipe. All joints in potable lines to be lead free.
- D. Install gate, ball, butterfly valves for shut-off and to isolate equipment, part of systems, or vertical risers.
- E. Install globe, ball, butterfly valves for throttling, bypass, or manual flow control services.
- F. Provide spring loaded check valves on discharge of water pumps.

### 3.4 TEST

- A. Upon completion of the domestic water piping system, it shall be tested and proved tight under a water pressure not less than 200 psi. The water used for testing shall be obtained from a potable source of supply. This pressure test shall be performed before the disinfection of the domestic water piping system is started. This test shall conform to the Louisiana State Plumbing Code
- B. Upon completion of the sanitary sewer piping system the contractor shall perform a water test to prove that the system is tight and without leaks. No section of the piping system shall be tested with less than 10 ft head of water. The pressure shall be kept on the system for a time no less than 1 hour. This test shall conform to the Louisiana State Plumbing Code.
- C. Upon completion of the sanitary vent piping system the contractor shall perform a pressure test to prove that the system is tight and without leaks. This test shall conform to the Louisiana State Plumbing Code.
- D. All Gas piping shall be tested in accordance to NFPA 54.
- E. Prior to any test, the Contractor shall notify the Architect in writing a minimum of 5 business days, the date and time the test will take place. No exceptions. After the completion of the test but before the building is substantially complete the contractor shall submit a written report with the following information for each test performed.
  - 1. Project Name
  - 2. Project Location
  - 3. Plumbing Contractor Name, Address and Contact Information
  - 4. Identification of test performed.
  - 5. Time and Date test was started
  - 6. Time and Date test was completed.

### 3.5 DISINFECTION OF DOMESTIC WATER PIPING SYSTEM:

- A. Prior to starting work, verify system is complete, flushed and clean.
- B. New or repaired potable water systems shall be purged of deleterious matter and disinfected prior to utilization. The method to be followed shall be that prescribed by the health authority or water purveyor having jurisdiction or, in the absence of a prescribed method, the procedure described in either AWWA C651 or AWWA C652, or as described in this section. This requirement shall apply to “onsite or in-plant” fabrication of a system or to a modular portion of a system.
  - 1. The pipe system shall be flushed with clean, potable water until dirty water does not appear at the points of outlet.
  - 2. The system or part thereof shall be filled with a water/chlorine solution containing not less than 50 parts per million (50 mg/L) of chlorine, and the system or part thereof shall be valved off and allowed to stand for 24 hours; or the system or part thereof shall be filled with a water/chlorine solution containing not less than 200 parts per million (200 mg/L) of chlorine and allowed to stand for 3 hours.
  - 3. Following the required standing time, the system shall be flushed with clean potable water until the chlorine is purged from the system.
  - 4. The procedure shall be repeated where shown by a bacteriological examination that contamination remains present in the system.
- C. Prior to the disinfection of the domestic water piping system the contractor shall inform the architect in writing the date and time the disinfection will take place. After the completion of the disinfection of the domestic water piping system but before the building is substantially completed the contractor shall submit a written report with the following information.
  - 1. Project Name
  - 2. Project Location
  - 3. Plumbing Contractors Name, Address, and contact information
  - 4. Chemicals used in the disinfection process.
  - 5. Time and Date disinfection process was started
  - 6. Time and Date disinfection process was completed

### 3.6 SERVICE CONNECTIONS:

- A. Provide new sanitary and storm sewer services and tie into existing as shown on plans. Before commencing work check invert elevations required for sewer connections, confirm inverts and insure that these can be properly connected with slope for drainage and cover to avoid freezing. Contractor to tie in existing services as shown on drawings.
- B. Tie domestic water into existing services as shown on drawings. Provide sleeve in wall for service main and support at wall with reinforced concrete bridge. Caulk enlarged sleeve and make watertight with pliable material. Provide 18-gauge galvanized sheet metal sleeve around service main to 6 inches above floor and 6 feet minimum below grade. Size for minimum of 2 inches of loose batt insulation stuffing. Contractor shall utilize and tie in existing water lines as indicated on the drawings.
- C. Tie new gas service into existing onsite. Coordinate connection with gas service provider.

END OF SECTION 22 10 00

## SECTION 22 10 10 - PLUMBING SPECIALTIES

### PART 1 - GENERAL

#### 1.1 WORK INCLUDED

- A. Floor drains
- B. Trap Primers
- C. Cleanouts
- D. Backflow preventors
- E. Water hammer arrestors
- F. Hose bibbs hydrants

#### 1.2 RELATED WORK

- A. Section 23 05 29 - Supports and Anchors
- B. Section 22 10 00 - Plumbing Piping
- C. Section 22 40 00 - Plumbing Fixtures

#### 1.3 REFERENCES

- A. ANSI/ASSE 1012 - Backflow Preventers with immediate Atmospheric Cent.
- B. ANSI/ASSE 1011 - Hose Connection Vacuum Breakers.
- C. ANSI/ASSE 1013 - Backflow Preventers, Reduced Pressure Principle.
- D. ANSI/ASSE 1019 - Wall Hydrants, Frost Proof Automatic Draining Anti-Backflow Types.
- E. ANSI A112.21.1 - Roof Drains
- F. ANSI A112.26.1 - Water Hammer Arrestors
- G. PDI WH-201 Water Hammer Arrestors

#### 1.4 QUALITY ASSURANCE

- A. Manufacturer: For each product specified, provide components by same manufacturer throughout.

#### 1.5 SUBMITTALS

- A. Submit shop drawings and product data under provisions of Section 01 30 00.

- B. Include component sizes, rough-in requirements, service sizes, and finishes.

## PART 2 - PRODUCTS

### 2.1 FLOOR DRAINS

- A. Floor Drain (FD): ANSI A112.21.1; lacquered cast iron two piece body with double drainage flange, weep holes, reversible clamping collar, square adjustable nickel- bronze strainer, and trap primer connection; Wade model 1100G, Zurn model Z415s or Smith model 2005.
- B. All floor drains installed shall have trap primers.

### 2.2 TRAP PRIMERS

- A. Trap primers shall be PPP, Inc. Prime-Rite 500 with AG-500 air gap fitting. Distribution unit may be used for multiple floor drains. Trap primers shall be installed as per manufacturer recommendations and in strict accordance with the Louisiana Plumbing Code. Elastomeric flexible type trap guards will not be allowed on this project.

### 2.3 ROOF DRAINS

- A. Roof Drains (RD): Duco Cast Iron body with adjustable extension sleeve, reversible collar, combined flashing clamp, under deck clamp, and gravel stop, with cast iron dome. Coordinate outlet with storm sewer piping. Wade model 3000-ADF, Zurn model Z100, or Smith model 1015.

### 2.4 EMERGENCY ROOF DRAIN

- A. Emergency roof drain (ERD): Duco cast iron body with adjustable extension sleeve, 2" high combination membrane flashing clamp/gravel guard with cast iron dome drain. Coordinate outlet size with storm sewer piping. Zurn Z-100, Wade, or Smith.

### 2.5 FLOOR SINK

- A. Floor sink (FS): 12"x12" floor sink with square nickel bronze top, 8" deep, aluminum dome strainer. Zurn Z1901, Wade 9144, or Smith 300.

### 2.6 CLEANOUTS

- A. Exterior Surfaced Areas: As detailed on Plans.
- B. Interior Finished Floor Areas: Lacquered cast iron, two piece body with double drainage flange, weep holes, reversible clamping collar, and adjustable nickel- bronze strainer, square with scoriated cover in service areas and square with depressed cover to accept floor finish in finished floor areas; Model W-6000 manufactured by Wade or Model ZN-1400 manufactured by Zurn or 4000 Series manufactured by Smith.
- C. Interior Finished Wall Areas: Line type with lacquered cast iron body and round epoxy coated gasketed cover, and round stainless steel access cover secured with machine screw; Model W-8460-R manufactured by Wade or Model ZN-1445-1 manufactured by Zurn or Model 4532 manufactured by Smith.



- D. Interior Unfinished Accessible Areas: Caulked or threaded type, provide bolted stack cleanouts on vertical rainwater leaders.
- E. Acceptable Manufacturers
  - 1. Wade 6000
  - 2. Zurn 1400
  - 3. Substitutions: Under provisions of Instructions To Bidders.

## 2.7 BACKFLOW PREVENTERS

- A. Pressure Backflow Preventers: ANSI/ASSE 1013; bronze body with bronze and plastic internal parts and Stainless steel springs; two independently operating, spring loaded check valves; diaphragm type differential pressure relief valve located between check valves; third check valve which opens under back pressure in case of diaphragm failure; non-threaded vent outlet; assembled with two gate valves, strainer, and four test cocks.
- B. Acceptable Manufacturers
  - 1. Watts Model 909
  - 2. Wilkins Model 375
  - 3. Substitutions: Under provisions of Instructions To Bidders.

## 2.8 REDUCED-PRESSURE-DETECTOR, FIRE-PROTECTION, BACKFLOW-PREVENTER ASSEMBLIES

- A. Basis-of-Design Product: Subject to compliance with requirements, provide product indicated on Drawings or comparable product by one of the following:
  - 1. Ames Fire & Waterworks; a Watts Water Technologies Company
  - 2. FEBCO; a Watts Water Technologies Company
  - 3. Watts Regulator; a Watts Water Technologies Company
  - 4. Substitutions: Under provisions of Instructions To Bidders
- B. Standard: ASSE 1047 and is FM Global approved or UL listed.
- C. Operation: Continuous-pressure applications.
- D. Pressure Loss: 12 psig maximum, through middle third of flow range.
- E. Body: Cast iron with interior lining that complies with AWWA C550 or that is FDA approved.
- F. End Connections: Flanged.
- G. Configuration: Designed for vertical-inlet, horizontal-center-section, and vertical-outlet flow.
- H. Accessories:
  - 1. Valves: Outside-screw and yoke-gate type with flanged ends on inlet and outlet.
  - 2. Air-Gap Fitting: ASME A112.1.2, matching backflow-preventer connection.
  - 3. Bypass: With displacement-type water meter, shutoff valves, and reduced-pressure backflow preventer.

## 2.9 WATER HAMMER ARRESTORS

- A. ANSI A112.26.1; sized in accordance with PDI WH-201, precharged suitable for operation in temperature range - 100 to 300 degrees F ( -73 to 49 Degrees C) and maximum 250 psig (1700 kpa) working pressure.
- B. Acceptable Manufactures
  - 1. Wade Model W-5, W-10, W-20
  - 2. Zurn Model Z-1700-100, 200, 300
  - 3. Smith Model 5000
  - 4. Substitutions: Under provisions of Instructions To Bidders.

## PART 3 - EXECUTION

### 3.1 PREPARATION

- A. Coordinate cutting forming of roof floor construction to receive drains to required invert elevations.

### 3.2 INSTALLATION AND APPLICATION

- A. Install specialties in accordance with manufacturer's instructions to permit intended performance.
- B. Extend cleanouts to finished floor or wall surface. Lubricate threaded cleanout plugs with mixture of graphite and linseed oil. Insure clearance at cleanout for rodding of drainage system.
- C. Encase exterior cleanouts in concrete flush with grade.
- D. Install water hammer arrestors complete with accessible isolation valve.
- E. In pipe 3 – inch nominal diameter or less, cleanouts shall be located at not more than 50ft.intervals
- F. In pipe 4 – inches nominal diameter through 6 inches nominal diameter, cleanouts shall be located at not more than 80ft. intervals
- G. Each building drain shall be provided with a cleanout within 6ft. of the junction of the building drain and building sewer.

END OF SECTION 22 10 10

## SECTION 22 40 00 - PLUMBING FIXTURES AND TRIM

### PART 1 - GENERAL

#### 1.1 SECTION INCLUDES

- A. Plumbing Fixtures and Trim

#### 1.2 RELATED WORK

- A. Section 23 00 00 - General Mechanical
- B. Section 22 10 00 - Plumbing Piping
- C. Section 22 10 10 - Plumbing Specialties

#### 1.3 SUBMITTALS

- A. Furnish and install plumbing fixtures as shown on the accompanying drawing and in accordance with the approved rough-in drawings. This will include service sinks, lavatories, water closets, urinals, etc., with all brass in connection with supply tubing, traps, escutcheons, stop and basin cocks, etc. All fixtures shall be new and must be delivered to the building properly crated and in perfect condition.
- B. All brass must be best quality. All brass pipe to be seamless brass tubing and all fixture traps shall be heavy with C.O. plugs. Nipples shall be extra heavy. Lightweight goods will not be accepted. All exposed metal on fixtures shall be C.P. or Chromard. All "P" traps shall be complete with cleanout plug.
- C. Contractor shall submit in his fixture brochure for approval, a rough-in sheet of each fixture and indicate any variation required for the fixtures. Fixtures are to be roughed-in in accordance with these approved rough-in sheets and anchored so that piping cannot be moved.

#### 1.4 JOB CONDITIONS

- A. Check millwork shop drawings. Conform location and size of fixtures and openings before rough-in and installation.

### PART 2 – PRODUCTS – see plans

### PART 3 - EXECUTION

#### 3.1 INSTALLATION

- A. Install furnish and install all plumbing fixtures and accessories according to manufacturer's instruction and according to national, state and local codes governing the various systems. Carefully review the Architectural floor plans and millwork details to determine exact number

of all fixtures, outlets, and accessories required. Coordinate all fixtures, outlets, drains, accessories, etc., prior to submitting shop drawings.

- B. Install each fixture in accordance with rough-in drawings as per manufacturers recommendations. At completion thoroughly clean plumbing fixtures and equipment. Anchor fixtures rigidly; anchor piping in walls so that piping cannot be moved.
- C. Provide chrome plated rigid or flexible supplies to fixtures with stops, reducers and escutcheons.
- D. Solidly attach floor water closets to floor with lag screws and finishing caps.
- E. Install each fixture with trap, easily removable for servicing and cleaning.
- F. All fixtures supplied with domestic water, hot or cold, shall be installed with integral stops on all supply lines.
- G. Mount fixtures to the following heights above finished floor:
  - 1. Water Closets:
    - a. Standard 15" to top of bowl rim
    - b. Handicapped 18" to top of seat
  - 2. Urinal:
    - a. Standard 22" to top of bowl rim
  - 3. Lavatories:
    - a. Handicapped 34" to top of basin rim
  - 4. Water Closet Flush Valves:
    - a. Standard 11" min. above bowl rim'
- H. Contractor shall caulk all joints at walls and floors with plumbing fixtures.
- I. Contractor shall provide approved ADA drain and water line insulation covers on all exposed services for lavatories and sinks. Truebro Lav Guard or approved equal.

3.2 FIXTURE ROUGH-IN SCHEDULE:

- A. Rough-in fixture piping and size connections shall be in accordance with the following table of minimum sizes for particular fixtures unless noted different on the drawing:

PLUMBING FIXTURE ROUGH-IN SCHEDULE

DESCRIPTION	C.W.	H.W.	WASTE	VENT
WATER CLOSET (TANK)	1/2"	–	4"	3"
WATER CLOSET (FLUSH VALVE)		1"	--	4" 3"
URINAL (FLUSH VALVE)	3/4"	--	2"	1-1/2"
LAVATORY	1/2"	--	2"	1-1/2"
SERVICE SINK	1/2"	1/2"	3"	2"
ELECTRIC WATER COOLER	1/2"	--	2"	1-1/2"
SINK	1/2"	1/2"	2"	1-1/2"

HOSE BIBB	3/4"	--	--	--
2" FLOOR DRAIN	--	--	2"	1-1/2"
3" FLOOR DRAIN	--	--	3"	2"
3" HUB DRAIN	--	--	3"	2"

WATER PIPE SIZING TABLE

UNLESS SHOWN OTHERWISE, DOMESTIC WATER LINES SHALL RUN CONCEALED OVERHEAD AS DESIGNATED IN PLUMBING FIXTURE SCHEDULE AND BE SIZED ACCORDING TO TABLE BELOW.

PLANS AND RISER DIAGRAMS DO NOT NECESSARILY SHOW ALL PIPING RUNS. INSTALL A FACTORY SHOCK ABSORBER AT TOP OF EACH FIXTURE GROUP AND ALSO AT WATER HEATERS.

NUMBER OF FIXTURES*	PIPE SIZE (IPS)
2 OR LESS	1/2"
3 TO 5	3/4"
6 TO 10	1"
11 TO 15	1-1/4"
16 TO 28	1-1/2"

\*FLUSH VALVE WATER CLOSET IS EQUIVALENT TO SIX (6) FIXTURES SIZES INDICATED ABOVE ARE MINIMUM SIZES TO BE USED UNLESS OTHERWISE STATED

END OF SECTION 22 40 00

## SECTION 23 00 00 - GENERAL MECHANICAL

### PART 1 - GENERAL CONDITIONS

#### 1.1 WORK INCLUDED

- A. The general conditions of the general specifications are made a part of these specifications and apply the same as if attached hereto. The contractor should, before bidding, read and thoroughly understand all general conditions, priority and scheduling.

#### 1.2 SCOPE OF WORK

- A. This section calls for the furnishing of labor, materials, equipment, and all the services, and of performing all operations required for the complete mechanical systems as hereinafter specified and/or shown on the accompanying drawings.

#### 1.3 GENERAL REQUIREMENTS

- A. Contractor shall install his work to meet the existing conditions as found at buildings and property, and to accommodate work of other trades. This contractor shall be responsible for timely placing of sleeves in forms before concrete is poured. Cooperate with the general contractor and place pipes and ducts in floors, walls, furred spaces, etc., so there will be no delay. Sheet metal or iron pipe sleeves shall be provided for pipes passing through floors, wall or partitions.
- B. Contractor shall furnish and properly install materials, devices, equipment, insulation, controls, appurtenances, etc., mentioned in these specifications and/or shown on plans or required to make a complete and satisfactory installation in working order whether fully shown or not.
- C. Contractor should visit the site and acquaint himself thoroughly with conditions governing installation of his work.
- D. All other plans shall be checked in relation to these plans so that all conditions will be furnished and installed in this contract to provide complete and satisfactory systems.

#### 1.4 LAWS, RULES, REGULATIONS, FEES, ETC.

- A. The entire mechanical work shall comply with rules and regulations of the local and state authorities having jurisdiction including the State Fire Marshal and the State Board of Health. All modifications required by the said authorities at any time shall be made by the mechanical contractor without additional charge. In cases where alterations to or deviations from this specification and accompanying plans are required by the authorities, contractor shall report same to the Architect and obtain his approval before work is started.

#### 1.5 DRAWINGS

- A. Plans and detail sketches are submitted to limit, explain, and define structural conditions, specified requirements, pipe sizes, and manner of erecting work. Structural or other conditions may require certain deviations from manner of installation shown, and such

deviations shall be made as required, but specified sizes and requirements necessary for satisfactory operation shall remain unchanged.

- B. It may be necessary to shift or to change routing of ducts and or piping and this shall be done, but such changes must be referred to Architect for approval before proceeding. Extra charges will not be allowed for these changes.
- C. Typical details are shown on plans, and in any cases where Contractor is not certain about the method of installation of this work, he shall ask for details, lack of details will not be an excuse for improper installation.
- D. Contractor bidding on this portion of the work must be fully experienced in installations of equal size, complexity and quality. In bidding, he acknowledges that he fully understands the scope of the work and design and has the ability, for the contract price to assemble and install the equipment, piping, and ductwork shown or specified, so as to mold same into a satisfactory workable system and arrangement, without responsibility for capacities and sizes set by these documents.
- E. Contractor shall recognize that the amount of information and detail that could be provided in Contract Documents is limitless and could extend into every minute detail, step, sequence, and operation to a point where only workmen would be required, without drawing on ability experience, and ingenuity of the Contractor.

#### 1.6 MATERIALS

- A. Where directed by the Architect, Contractor shall submit sample for approval before proceeding.

#### 1.7 STANDARDS

- A. In general, standards for products and workmanship shall be as described in each individual section.
- B. The standards referred to, except as modified in these specifications shall have full force and effect as though printed in these specifications. These standards are not furnished to bidders for the reason that the manufacturers and trades involved are assumed to be familiar with their requirements. The Architect will furnish, upon request, information as to how copies of the standards referred to may be obtained.
- C. Notwithstanding any reference in this section of the specifications to any article, device, product, material, fixture, form or type of construction by name, make or catalogue number, such references shall be interpreted as establishing a standard of quality and shall not be construed limiting competition and the Contractor in such cases, may at his option, use any article, device, product, material, fixture, form or type of construction which in the judgment of the Architect, expressed in writing, is equal to that specified.

#### 1.8 MATERIALS SPECIFIED OR SUBSTITUTED (Prior Approvals)

- A. Refer to Instructions to Bidders.

#### 1.9 SHOP DRAWINGS

- A. Before proceeding with the work, contractor shall make complete shop and working drawings of such apparatus or connections as directed by the Architect and/or hereinafter specified. These drawings shall show construction details and dimensions of each piece of equipment so drawn.
- B. Architects approval of shop drawings shall not relieve the Contractor from responsibility of incorrectly figured dimensions or any other errors in these drawings or specified even though approved by the Architect, shall not relieve this Contractor from furnishing and erecting same.
- C. Ten (10) sets of prints of shop drawings shall be submitted to Architect for approval. These prints shall be supplied as part of this contract. Submit all shop drawings at the same time or as soon as practical after award of the contract. No separate items will be accepted.
- D. Where laws or local regulations provide that certain accessories such as gauges, thermometers, relief valves and parts be installed on equipment, it shall be understood that such accessories shall be furnished if no specific reference to them is made in the specifications.

#### 1.10 CUTTING AND PATCHING

- A. All cutting necessary for this work will be done by this Contractor at his own expense, but all patching shall be done by the General Contractor. No beams or joists shall be cut without prior approval of Architect. After initial resurfacing has been done any further cutting, patching or painting shall be done at the expense of this Contractor.

#### 1.11 INTERFERENCES

- A. The drawings are generally diagrammatic and this Contractor shall harmonize his work with that of the different trades so that interferences of the different equipment, piping, etc., shall be installed so as to function properly. In the case where interference develops, the Architect is to state which equipment, piping, etc., is to be relocated regardless of which item was first installed.

#### 1.12 EXCAVATION AND BACKFILL

- A. This Contractor shall do all excavating required to lay the specified services and after same have been laid, he shall do all backfilling to the satisfaction of all parties concerned and shall cart away from the premises all unnecessary dirt, rubbish, etc., as directed. Backfill shall be well tamped. All backfill shall be done according to the "Compaction And Backfill" section of these specifications.

#### 1.13 SPACE REQUIREMENTS

- A. Contractor shall check all plans pertaining to this job so as to be fully aware of the space limitations for all various items of equipment. Equipment is not to be bid on, submitted for preliminary approval nor placed on the job if it is so bulky and large that adequate access for proper maintenance and servicing cannot be achieved in the space provided.

#### 1.14 FOUNDATIONS AND SUPPORTS



- A. This contractor shall furnish and install foundations and supports of concrete or steel shapes for equipment requiring same, unless specifically indicated otherwise or specified.
  - B. All floor mounted mechanical equipment shall be mounted on 4" high concrete housekeeping pad unless specifically shown otherwise on plans. Refer to plans for special requirements for foundations and supports.
- 1.15 HANGERS, ESCUTCHEONS, ETC.
- A. See Section 23 05 29 – Supports and Anchors.
  - B. Mechanical Contractor shall furnish and install all thimbles, inserts and other requirements necessary for the support of his equipment and piping. Assist and cooperate with other trades in locating and placing these items.
- 1.16 CEILING AND WALL ACCESS PANEL
- A. Factory made access doors and frames, prime coat finish, screw driver latch(s) of suitable size as required.
  - B. Access panels in rated ceiling to have same rating as ceiling.
  - C. Where valves, dampers, controls, fire dampers, smoke dampers, and detectors, reheat coils, etc. are concealed in walls or non-accessible ceilings, install factory made access doors and frames.
- 1.17 DUCTWORK ACCESS PANELS
- A. Access panels in ductwork to be double wall type with insulation sandwiched in between, same insulation value as adjacent ductwork.
- 1.18 SIPHON PREVENTERS
- A. Furnish and install approved type siphon preventors on all equipment and fixtures in such a manner as to prevent water being siphoned back into the water supply in the event the water supply is shut off.
- 1.19 FLAME SPREAD PROPERTIES OF MATERIALS
- A. All materials and adhesives used for acoustical linings, jackets and insulation shall comply with requirements of NFPA 90A and 90B and UL guide # 40V.8.15. Products exceeding a flame spread rating of 25, or a smoke developed rating of 50, as determined by ASTM Test Method E-84 are prohibited. Adhesives and sealers shall be fire retardant and fire resistant when dry. Flame proofing treatments which are subject to decomposition, deterioration, or the effects of moisture are prohibited.
- 1.20 DOMESTIC AND FIRE WATER TIE-IN
- A. Contractor shall provide any necessary meters and tap fees for domestic or fire water tie-ins to utility companies. All domestic and fire water taps shall have aboveground reduced pressure back flow preventors near the tie-in point. Coordinate with Engineer exact location.

- B. All backflow preventors shall be heat traced and insulated with 1-1/2" fiberglass insulation with water tight aluminum jacket.

#### 1.21 PROTECTION OF EQUIPMENT

- A. See individual sections for protection of equipment.
- B. This Contractor shall at all times take such precautions as may be necessary to properly protect his equipment from damage. Failure on the part of the Contractor to comply with the above to the entire satisfaction of the Architect will be sufficient cause for the rejection of the particular piece of equipment in question.

#### 1.22 TESTING

- A. All pressure lines, unless elsewhere specified, shall be tested under 150# hydrostatic pressure unless rated pressure is less for a minimum of 5 hours. Contractor shall provide valve at farthest point in line to bleed off air and for inspection.
- B. Notice shall be given the Architect before tests are made, the test is not to be drawn off pipes and pipes are not to be covered or insulated until filled pipes have been examined and testing approved by the Architect.
- C. In case of defects, they shall be made good to the satisfaction of the Architect and work retested. All such work shall be done by the Contractor with no additional expense to the Owner.
- D. Contractor shall make any other such tests as may be called for by the Architect, and all other tests so called for elsewhere in these specifications.

#### 1.23 CLEANING AND ADJUSTING

- A. Before receiving final approval from the Architect, the Contractor shall clean out all lines; adjust all valves, control equipment and other equipment. Clean all pipe and equipment and leave the entire installation in good working order. All heaters, fans, grilles, controls, etc., shall be adjusted to perform in correct and satisfactory manner, with sequences, etc., as called for in the specifications hereinafter specified and on plans.

#### 1.24 PAINTING

- A. Refer to Section 09 90 00 – Painting and Coating and 230553 – Mechanical Identification for painting requirements.

#### 1.25 MOTORS, MOTOR STARTERS AND ELECTRICAL WORK

- A. Refer to Section 23 05 13 - Motors.
- B. Motors shall be suitable for voltage indicated on the plans, plus or minus 10% and be designed for constant operation at 40 degrees C ambient, 65 degrees C rise for class A, 90 degrees C rise for Class B, etc. Electrical equipment furnished under this contract shall meet standards as set forth by NEMA and NEC requirements. All electrical equipment shall be UL labeled.

#### 1.26 PARTS LIST AND INSTRUCTION MANUAL

- A. See individual sections for specific instructions.
- B. This Contractor shall deliver to the Architect three (3) copies of printed instructions relating to operating, proper maintenance and repair parts list indicating the various parts by name, number and diagram for each piece of equipment installed. Test and balance report shall also be included in parts list and instruction manual.
- C. The shop drawings, parts list, and maintenance and repair instructions shall be neatly bound in a canvas-covered notebook and turned over to the Architect before acceptance of the work.

#### 1.27 BOILER TEST CERTIFICATES

- A. Each boiler, water heater (with a capacity equal to or greater than 50 gallons), and pressure vessels are to be inspected by a State of Louisiana certified inspector upon installation.
- B. Submit a copy of each report to the Architect and include one copy in each of the Close-out Manuals.

#### 1.28 GUARANTEE

- A. Contractor shall guarantee materials, equipment and workmanship installed and performed under this contract for a period of one (1) year from date of the final completion and official acceptance of the contract.
- B. He shall furnish free of charge to the Owner all materials and labor necessary to comply with the above guarantee, which shall be based on defective materials and/or workmanship, and on such basis shall be responsible if a deficiency is found, for any adjustment, replacement, or correction which may be necessary to replace the project to first class condition. This guarantee shall include refrigerant charges, but shall not include the changing of filters.

#### 1.29 RECORD DRAWINGS

- A. The Contractor shall maintain a set of record drawings on-site throughout the construction. The record drawings shall reflect accurate dimensional record of all underground, buried, above ceiling, or otherwise concealed work.
- B. The Contractor shall maintain these record documents and keep them up-to-date daily.

END OF SECTION 23 00 00

## SECTION 23 05 00 - BASIC MECHANICAL MATERIALS AND METHODS

### PART 1 - GENERAL

#### 1.1 SUMMARY

- A. This Section includes the following:
  - 1. Piping materials and installation instructions common to most piping systems.
  - 2. Dielectric fittings.
  - 3. Mechanical sleeve seals.
  - 4. Sleeves.
  - 5. Escutcheons.
  - 6. Grout.
  - 7. Mechanical demolition.
  - 8. Equipment installation requirements common to equipment sections.
  - 9. Concrete bases.
  - 10. Supports and anchorages.

#### 1.2 DEFINITIONS

- A. Finished Spaces: Spaces other than mechanical and electrical equipment rooms, furred spaces, pipe and duct shafts, unheated spaces immediately below roof, spaces above ceilings, unexcavated spaces, crawlspaces, and tunnels.
- B. Exposed, Interior Installations: Exposed to view indoors. Examples include finished occupied spaces and mechanical equipment rooms.
- C. Exposed, Exterior Installations: Exposed to view outdoors or subject to outdoor ambient temperatures and weather conditions. Examples include rooftop locations.
- D. Concealed, Interior Installations: Concealed from view and protected from physical contact by building occupants. Examples include above ceilings and in duct shafts.
- E. Concealed, Exterior Installations: Concealed from view and protected from weather conditions and physical contact by building occupants but subject to outdoor ambient temperatures. Examples include installations within unheated shelters.

#### 1.3 SUBMITTALS

- A. Welding certificates.

#### 1.4 QUALITY ASSURANCE

- A. Steel Support Welding: Qualify processes and operators according to AWS D1.1, "Structural Welding Code--Steel."
- B. Steel Pipe Welding: Qualify processes and operators according to ASME Boiler and Pressure Vessel Code: Section IX, "Welding and Brazing Qualifications."
  - 1. Comply with provisions in ASME B31 Series, "Code for Pressure Piping."

2. Certify that each welder has passed AWS qualification tests for welding processes involved and that certification is current.
- C. Electrical Characteristics for Mechanical Equipment: Equipment of higher electrical characteristics may be furnished provided such proposed equipment is approved in writing and connecting electrical services, circuit breakers, and conduit sizes are appropriately modified. If minimum energy ratings or efficiencies are specified, equipment shall comply with requirements.

## PART 2 - PRODUCTS

### 2.1 PIPE, TUBE, AND FITTINGS

- A. Refer to individual Division 23 piping Sections for pipe, tube, and fitting materials and joining methods.
- B. Pipe Threads: ASME B1.20.1 for factory-threaded pipe and pipe fittings.

### 2.2 JOINING MATERIALS

- A. Refer to individual Division 23 piping Sections for special joining materials not listed below.
- B. Pipe-Flange Gasket Materials: ASME B16.21, nonmetallic, flat, asbestos-free, 1/8-inch (3.2-mm) maximum thickness unless thickness or specific material is indicated.
- C. Plastic, Pipe-Flange Gasket, Bolts, and Nuts: Type and material recommended by piping system manufacturer, unless otherwise indicated.
- D. Solder Filler Metals: ASTM B 32, lead-free alloys. Include water-flushable flux according to ASTM B 813.
- E. Brazing Filler Metals: AWS A5.8, BCuP Series or BAg1, unless otherwise indicated.
- F. Welding Filler Metals: Comply with AWS D10.12.
- G. Solvent Cements for Joining Plastic Piping:
  1. ABS Piping: ASTM D 2235.
  2. CPVC Piping: ASTM F 493.
  3. PVC Piping: ASTM D 2564. Include primer according to ASTM F 656.
  4. PVC to ABS Piping Transition: ASTM D 3138.

### 2.3 DIELECTRIC FITTINGS

- A. Description: Combination fitting of copper alloy and ferrous materials with threaded, solder-joint, plain, or weld-neck end connections that match piping system materials.

- B. Insulating Material: Suitable for system fluid, pressure, and temperature.
- C. Dielectric Unions: Factory-fabricated, union assembly, for 250-psig (1725-kPa) minimum working pressure at 180 deg F (82 deg C).
- D. Dielectric Flanges: Factory-fabricated, companion-flange assembly, for 150- or 300-psig (1035- or 2070-kPa) minimum working pressure as required to suit system pressures.
- E. Dielectric Couplings: Galvanized-steel coupling with inert and noncorrosive, thermoplastic lining; threaded ends; and 300-psig (2070-kPa) minimum working pressure at 225 deg F (107 deg C).
- F. Dielectric Nipples: Electroplated steel nipple with inert and noncorrosive, thermoplastic lining; plain, threaded, or grooved ends; and 300-psig (2070-kPa) minimum working pressure at 225 deg F (107 deg C).

#### 2.4 MECHANICAL SLEEVE SEALS

- A. Description: Modular sealing element unit, designed for field assembly, to fill annular space between pipe and sleeve.
- B. Sealing Elements: NBR interlocking links shaped to fit surface of pipe. Include type and number required for pipe material and size of pipe.
- C. Pressure Plates: Carbon steel. Include two for each sealing element.
- D. Connecting Bolts and Nuts: Stainless steel of length required to secure pressure plates to sealing elements. Include one for each sealing element.

#### 2.5 SLEEVES

- A. Galvanized-Steel Sheet: 0.0239-inch (0.6-mm) minimum thickness; round tube closed with welded longitudinal joint.
- B. Steel Pipe: ASTM A 53, Type E, Grade B, Schedule 40, galvanized, plain ends.
- C. Cast Iron: Cast or fabricated "wall pipe" equivalent to ductile-iron pressure pipe, with plain ends and integral waterstop, unless otherwise indicated.
- D. Stack Sleeve Fittings: Manufactured, cast-iron sleeve with integral clamping flange. Include clamping ring and bolts and nuts for membrane flashing.
  - 1. Underdeck Clamp: Clamping ring with set screws.
- E. Molded PVC: Permanent, with nailing flange for attaching to wooden forms.
- F. PVC Pipe: ASTM D 1785, Schedule 40.
- G. Molded PE: Reusable, PE, tapered-cup shaped, and smooth-outer surface with nailing flange for attaching to wooden forms.

#### 2.6 ESCUTCHEONS

- A. Description: Manufactured wall and ceiling escutcheons and floor plates, with an ID to closely fit around pipe, tube, and insulation of insulated piping and an OD that completely covers opening.
- B. One-Piece, Deep-Pattern Type: Deep-drawn, box-shaped brass with polished chrome-plated finish.
- C. One-Piece, Cast-Brass Type: With set screw.
  - 1. Finish: Polished chrome-plated and rough brass.
- D. Split-Casting, Cast-Brass Type: With concealed hinge and set screw.
  - 1. Finish: Polished chrome-plated and rough brass.

## 2.7 GROUT

- A. Description: ASTM C 1107, Grade B, nonshrink and nonmetallic, dry hydraulic-cement grout.
  - 1. Characteristics: Post-hardening, volume-adjusting, nonstaining, noncorrosive, nongaseous, and recommended for interior and exterior applications.
  - 2. Design Mix: 5000-psi (34.5-MPa), 28-day compressive strength.
  - 3. Packaging: Premixed and factory packaged.

## PART 3 - EXECUTION

### 3.1 MECHANICAL DEMOLITION

- A. Refer to Division 1 Sections "Cutting and Patching" and "Selective Demolition" for general demolition requirements and procedures.
- B. Disconnect, demolish, and remove mechanical systems, equipment, and components indicated to be removed.
  - 1. Piping to Be Removed: Remove portion of piping indicated to be removed and cap or plug remaining piping with same or compatible piping material.
  - 2. Piping to Be Abandoned in Place: Drain piping and cap or plug piping with same or compatible piping material.
  - 3. Ducts to Be Removed: Remove portion of ducts indicated to be removed and plug remaining ducts with same or compatible ductwork material.
  - 4. Ducts to Be Abandoned in Place: Cap or plug ducts with same or compatible ductwork material.
  - 5. Equipment to Be Removed: Disconnect and cap services and remove equipment.
  - 6. Equipment to Be Removed and Reinstalled: Disconnect and cap services and remove, clean, and store equipment; when appropriate, reinstall, reconnect, and make equipment operational.
  - 7. Equipment to Be Removed and Salvaged: Disconnect and cap services and remove equipment and deliver to Owner.
- C. If pipe, insulation, or equipment to remain is damaged in appearance or is unserviceable, remove damaged or unserviceable portions and replace with new products of equal capacity and quality.

### 3.2 PIPING SYSTEMS - COMMON REQUIREMENTS

- A. Install piping according to the following requirements and Division 23 Sections specifying piping systems.
- B. Drawing plans, schematics, and diagrams indicate general location and arrangement of piping systems. Indicated locations and arrangements were used to size pipe and calculate friction loss, expansion, pump sizing, and other design considerations. Install piping as indicated unless deviations to layout are approved on Coordination Drawings.
- C. Install piping in concealed locations, unless otherwise indicated and except in equipment rooms and service areas.
- D. Install piping indicated to be exposed and piping in equipment rooms and service areas at right angles or parallel to building walls. Diagonal runs are prohibited unless specifically indicated otherwise.
- E. Install piping above accessible ceilings to allow sufficient space for ceiling panel removal.
- F. Install piping to permit valve servicing.
- G. Install piping at indicated slopes.
- H. Install piping free of sags and bends.
- I. Install fittings for changes in direction and branch connections.
- J. Install piping to allow application of insulation.
- K. Select system components with pressure rating equal to or greater than system operating pressure.
- L. Install escutcheons for penetrations of walls, ceilings, and floors.
- M. Install sleeves for pipes passing through concrete and masonry walls, gypsum-board partitions, and concrete floor and roof slabs.
- N. Aboveground, Exterior-Wall Pipe Penetrations: Seal penetrations using sleeves and mechanical sleeve seals. Select sleeve size to allow for 1-inch (25-mm) annular clear space between pipe and sleeve for installing mechanical sleeve seals.
  - 1. Install steel pipe for sleeves smaller than 6 inches (150 mm) in diameter.
  - 2. Install cast-iron "wall pipes" for sleeves 6 inches (150 mm) and larger in diameter.
  - 3. Mechanical Sleeve Seal Installation: Select type and number of sealing elements required for pipe material and size. Position pipe in center of sleeve. Assemble mechanical sleeve seals and install in annular space between pipe and sleeve. Tighten bolts against pressure plates that cause sealing elements to expand and make watertight seal.
- O. Underground, Exterior-Wall Pipe Penetrations: Install cast-iron "wall pipes" for sleeves. Seal pipe penetrations using mechanical sleeve seals. Select sleeve size to allow for 1-



inch (25-mm) annular clear space between pipe and sleeve for installing mechanical sleeve seals.

1. Mechanical Sleeve Seal Installation: Select type and number of sealing elements required for pipe material and size. Position pipe in center of sleeve. Assemble mechanical sleeve seals and install in annular space between pipe and sleeve. Tighten bolts against pressure plates that cause sealing elements to expand and make watertight seal.
- P. Fire-Barrier Penetrations: Maintain indicated fire rating of walls, partitions, ceilings, and floors at pipe penetrations. Seal pipe penetrations with firestop materials. Refer to Division 7 Section "Through-Penetration Firestop Systems" for materials.
- Q. Verify final equipment locations for roughing-in.
- R. Refer to equipment specifications in other Sections of these Specifications for roughing-in requirements.

### 3.3 PIPING JOINT CONSTRUCTION

- A. Join pipe and fittings according to the following requirements and Division 15 Sections specifying piping systems.
- B. Ream ends of pipes and tubes and remove burrs. Bevel plain ends of steel pipe.
- C. Remove scale, slag, dirt, and debris from inside and outside of pipe and fittings before assembly.
- D. Soldered Joints: Apply ASTM B 813, water-flushable flux, unless otherwise indicated, to tube end. Construct joints according to ASTM B 828 or CDA's "Copper Tube Handbook," using lead-free solder alloy complying with ASTM B 32.
- E. Brazed Joints: Construct joints according to AWS's "Brazing Handbook," "Pipe and Tube" Chapter, using copper-phosphorus brazing filler metal complying with AWS A5.8.
- F. Threaded Joints: Thread pipe with tapered pipe threads according to ASME B1.20.1. Cut threads full and clean using sharp dies. Ream threaded pipe ends to remove burrs and restore full ID. Join pipe fittings and valves as follows:
  1. Apply appropriate tape or thread compound to external pipe threads unless dry seal threading is specified.
  2. Damaged Threads: Do not use pipe or pipe fittings with threads that are corroded or damaged. Do not use pipe sections that have cracked or open welds.
- G. Welded Joints: Construct joints according to AWS D10.12, using qualified processes and welding operators according to Part 1 "Quality Assurance" Article.
- H. Flanged Joints: Select appropriate gasket material, size, type, and thickness for service application. Install gasket concentrically positioned. Use suitable lubricants on bolt threads.
- I. Plastic Piping Solvent-Cement Joints: Clean and dry joining surfaces. Join pipe and fittings according to the following:

1. Comply with ASTM F 402, for safe-handling practice of cleaners, primers, and solvent cements.
2. ABS Piping: Join according to ASTM D 2235 and ASTM D 2661 Appendixes.
3. CPVC Piping: Join according to ASTM D 2846/D 2846M Appendix.
4. PVC Pressure Piping: Join schedule number ASTM D 1785, PVC pipe and PVC socket fittings according to ASTM D 2672. Join other-than-schedule-number PVC pipe and socket fittings according to ASTM D 2855.
5. PVC Nonpressure Piping: Join according to ASTM D 2855.
6. PVC to ABS Nonpressure Transition Fittings: Join according to ASTM D 3138 Appendix.

J. Plastic Pressure Piping Gasketed Joints: Join according to ASTM D 3139.

K. Plastic Nonpressure Piping Gasketed Joints: Join according to ASTM D 3212.

L. PE Piping Heat-Fusion Joints: Clean and dry joining surfaces by wiping with clean cloth or paper towels. Join according to ASTM D 2657.

1. Plain-End Pipe and Fittings: Use butt fusion.
2. Plain-End Pipe and Socket Fittings: Use socket fusion.

M. Fiberglass Bonded Joints: Prepare pipe ends and fittings, apply adhesive, and join according to pipe manufacturer's written instructions.

### 3.4 PIPING CONNECTIONS

A. Make connections according to the following, unless otherwise indicated:

1. Install unions, in piping NPS 2 (DN 50) and smaller, adjacent to each valve and at final connection to each piece of equipment.
2. Install flanges, in piping NPS 2-1/2 (DN 65) and larger, adjacent to flanged valves and at final connection to each piece of equipment.
3. Dry Piping Systems: Install dielectric unions and flanges to connect piping materials of dissimilar metals.
4. Wet Piping Systems: Install dielectric coupling and nipple fittings to connect piping materials of dissimilar metals.

### 3.5 EQUIPMENT INSTALLATION - COMMON REQUIREMENTS

A. Install equipment to allow maximum possible headroom unless specific mounting heights are not indicated.

B. Install equipment level and plumb, parallel and perpendicular to other building systems and components in exposed interior spaces, unless otherwise indicated.

C. Install mechanical equipment to facilitate service, maintenance, and repair or replacement of components. Connect equipment for ease of disconnecting, with minimum interference to other installations. Extend grease fittings to accessible locations.

D. Install equipment to allow right of way for piping installed at required slope.

### 3.6 CONCRETE BASES

- A. Concrete Bases: Anchor equipment to concrete base according to equipment manufacturer's written instructions and according to seismic codes at Project.
  - 1. Construct concrete bases of dimensions indicated, but not less than 4 inches (100 mm) larger in both directions than supported unit.
  - 2. Install dowel rods to connect concrete base to concrete floor. Unless otherwise indicated, install dowel rods on 18-inch (450-mm) centers around the full perimeter of the base.
  - 3. Install epoxy-coated anchor bolts for supported equipment that extend through concrete base, and anchor into structural concrete floor.
  - 4. Place and secure anchorage devices. Use supported equipment manufacturer's setting drawings, templates, diagrams, instructions, and directions furnished with items to be embedded.
  - 5. Install anchor bolts to elevations required for proper attachment to supported equipment.
  - 6. Install anchor bolts according to anchor-bolt manufacturer's written instructions.
  - 7. Use 3000-psi (20.7-MPa), 28-day compressive-strength concrete and reinforcement.

### 3.7 ERECTION OF METAL SUPPORTS AND ANCHORAGES

- A. Refer to Division 5 Section "Metal Fabrications" for structural steel.
- B. Cut, fit, and place miscellaneous metal supports accurately in location, alignment, and elevation to support and anchor mechanical materials and equipment.
- C. Field Welding: Comply with AWS D1.1.

### 3.8 ERECTION OF WOOD SUPPORTS AND ANCHORAGES

- A. Cut, fit, and place wood grounds, nailers, blocking, and anchorages to support, and anchor mechanical materials and equipment.
- B. Select fastener sizes that will not penetrate members if opposite side will be exposed to view or will receive finish materials. Tighten connections between members. Install fasteners without splitting wood members.
- C. Attach to substrates as required to support applied loads.

### 3.9 GROUTING

- A. Mix and install grout for mechanical equipment base bearing surfaces, pump and other equipment base plates, and anchors.
- B. Clean surfaces that will come into contact with grout.
- C. Provide forms as required for placement of grout.
- D. Avoid air entrapment during placement of grout.
- E. Place grout, completely filling equipment bases.

- F. Place grout on concrete bases and provide smooth bearing surface for equipment.
- G. Place grout around anchors.
- H. Cure placed grout.

END OF SECTION 23 05 00

## SECTION 23 05 13 - MOTORS

### PART 1 - GENERAL

#### 1.1 SECTION INCLUDES

- A. Single phase electric motors.
- B. Three phase electric motors.

#### 1.2 RELATED WORK

- A. Section 23 21 23 - Pumps

#### 1.3 REFERENCES

- A. AFBMA 9 - Load Ratings and Fatigue Life for Ball Bearings.
- B. AFBMA 11 - Load Ratings and Fatigue Life for Roller Bearings.
- C. ANSI/IEEE 112 - Test Procedure for Polyphase Induction Motors and Generators.
- D. ANSI/NEMA MG 1 - Motors and Generators
- E. ANSI/NEMA 70 - National Electrical Code

#### 1.4 SUBMITTALS

- A. Submit product data under provisions of Sections 01 30 00 - Administrative Requirements & 23 00 00 – General Mechanical.
- B. Submit test results verifying nominal efficiency and power factor for three phase motors larger than 5 horsepower.

#### 1.5 OPERATION AND MAINTENANCE DATA

- A. Submit operation and maintenance data under provisions of Section 01 70 00 - Execution Requirements.
- B. Include assembly drawings, bearing data including replacement sizes, and lubrication instructions.

#### 1.6 QUALIFICATIONS

- A. Manufacturer: Company specializing in manufacture of electric motors for commercial use, and their accessories, with documented product development, testing, and manufacturing experience.

#### 1.7 REGULATORY REQUIREMENTS

- A. Conform to ANSI/NFPA 70.

## 1.8 DELIVERY, STORAGE, AND HANDLING

- A. Deliver products to site under provisions of Section 01 60 00 – Product Requirements.
- B. Store and protect products under provisions of Section 01 60 00– Product Requirements.
- C. Protect motors stored on site from weather and moisture by maintaining factory covers and suitable weather-proof covering. (For extended outdoor storage, remove motors from equipment and store separately).

## 1.9 WARRANTY - See General Section 23 00 00– General Mechanical.

## PART 2 - PRODUCTS

### 2.1 MOTORS

- A. Motors controlled by VFD's shall comply with NEMA MG1, Part 31, Definite Purpose Inverter Fed Motors (withstand repeated voltage peaks of 1600V with rise times of 0.1 microseconds and greater).
- B. Starters for single phase motors which are not automatically started shall be manual type with melting alloy thermal overload protection and pilot light. Starters for automatically controlled single phase motors shall be magnetic type with NEMA rated AC magnetic contactor, melting alloy thermal overloads and pilot light.
- C. Starters for three phase motors 25 horsepower and below shall be combination type starter/disconnect, full voltage non reversing (FVNR), with magnetic NEMA rated contactors rated for horsepower of motor served, adjustable trip magnetic circuit breaker disconnect (circuit breaker, not a fused switch) capable of being padlocked in the open position, 10K a/c minimum fault rating with higher rating when necessary due to available fault levels. Starters shall have a fused 100VA minimum control transformer (120V unless required otherwise), HOA switch, push to test operating pilot light, solid state overload relays set for actual motor nameplate full load amps, phase failure and phase reversal protection relay, minimum two NO. and two N.C auxiliary contacts and terminal blocks factory prewired for field wiring. Starters shall be housed in a NEMA 1 enclosure for indoor locations and NEMA 3R enclosure for outdoor or wet locations.
- D. Starter for motors 30 horsepower and above shall be soft start type or variable frequency drives
- E. Coordinate with electrical and specify fault rating on all motor controllers.

### 2.2 MANUFACTURERS

- A. Electrical Service - Refer to Division 26 for required electrical characteristics.
- B. Motors: Design for continuous operation in 40 degrees C environment, and for temperature rise in accordance with ANSI/NEMA MG 1 limits for insulation class, Service Factor, and motor enclosure type.

- C. Visible Nameplate: Indicating motor information as required by NEC 430-7(a).
  - D. Electrical Connection: Conduit connection boxes, threaded for conduit. For fractional horsepower motors where connection is made directly, provide screwed conduit connection in end frame.
  - E. Starters: General electric, Cerus Industrial
- 2.3 SINGLE PHASE POWER - PERMANENT-SPLIT CAPACITOR MOTORS
- A. Starting Torque: Exceeding one fourth of full load torque.
  - B. Starting Current: Up to six times full load current.
  - C. Multiple Speed: Through tapped windings.
  - D. Open Drip-proof or Enclosed Air Over Enclosure: Class A 65 degree C temperature rise insulation, Minimum 1.15 service factor, pre-lubricated sleeve or ball bearings, automatic reset overload protector.
- 2.4 SINGLE PHASE POWER - CAPACITOR START MOTORS
- A. Starting Torque: Three times full load torque.
  - B. Starting Current: Less than five times full load current.
  - C. Pull-up Torque: Up to 350 percent of full load torque.
  - D. Breakdown Torque: Approximately 250 percent of full load torque.
  - E. Motors: Capacitor in series with starting winding; capacitor-start/capacitor-run motors shall have two capacitors in parallel with run capacitor remaining in circuit at operating speeds.
  - F. Drip-proof Enclosure: Class A 65 degree C temperature rise insulation, NEMA service factor, prelubricated sleeve ball bearings.
  - G. Enclosed Motors: Class A 65 degree C temperature rise insulation, NEMA service factor, prelubricated sleeve ball bearings.
- 2.5 THREE PHASE POWER - SQUIRREL CAGE MOTORS
- A. Starting Torque: Between one and one-half times full load torque.
  - B. Starting Current: Six times full load current.
  - C. Power Output, Locked Rotor Torque, Breakdown or Pullout Torque: NEMA Design B characteristics.
  - D. Design, Construction, Testing, and Performance: Conform to ANSI/NEMA MG for design B motors.
  - E. Insulation System: NEMA Class B or better.

- F. Testing Procedure: In accordance with ANSI/IEEE 12, Test Method B. Load test motors to determine freedom from electrical or mechanical defects and compliance with performance data.
- G. Motor Frames: NEMA standard T-frames of steel, aluminum, or cast iron with end brackets of cast iron or aluminum with steel inserts.
- H. Thermister System (Motor Frame Sizes 254T and larger): Three PTC thermister imbedded in motor windings and epoxy encapsulated solid state control relay for wiring into motor starter.
- I. Bearings: Grease lubricated anti-friction ball bearings with housings equipped with plugged provision for re-lubrication, rated for minimum AFBMA 9, L-10 life of 20,000 hours. Calculate bearing load with NEMA minimum V-belt pulley with belt center line at end of NEMA standard shaft extension. Stamp bearing sizes on nameplate.
- J. Sound Power Levels: To ANSI/NEMA MG1.
- K. Nominal Efficiency: Meet or exceed values in schedules at full load and rated voltage when tested in accordance with ANSI/IEEE 112, and ASHRAE 90.1.
- L. Motors, Motor Starters and Electrical Work: Mechanical Contractor shall furnish all motors, motor starters, start-stop push buttons, pilot lights, firestats, interlocking diagrams, etc. for each piece of motor driven equipment under this Contract. Mechanical Contractor shall install all motors. All motor starters, start-stop push buttons, pilot lights, etc. shall be turned over to the Electrical Contractor for installation. Electrical contractor shall be responsible for power wiring. This contractor will be responsible for control wiring.
- M. Motor Starters and Push Buttons: All automatic starters shall be nominal 600 volt rating. All starters shall have two (2) auxiliary contacts.
  - 1. Starters for single speed motors, 3/4 through 25 HP inclusive, shall be magnetically operated, "Across-the-line" 3 phase, with three overload relays, "HAND-OFF-AUTO" selector switch and pilot in cover. Starters shall be combination type with fused or circuit breaker type disconnect mechanism.
  - 2. Starters for 30 HP and larger are to be reduced voltage, auto-transformer, combination type with fused or circuit breaker type disconnect mechanism. Starters shall be complete with three overload relays, "HAND-OFF-AUTO" selector switch and pilot lights.
  - 3. Enclosures for starters mounted indoors shall be NEMA 1. Enclosures for starters mounted outdoors or in wet areas shall be NEMA 3 R.
  - 4. Remote push button stations shall be as follows: Start-stop stations shall be recess mounted with neon pilot lamp of proper voltage.
  - 5. Push buttons for controls which are interlocked with automatic controls shall be maintained contact type. All others may be of momentary contact type.
  - 6. Control voltage for all motor starters shall 120 volts provided by integral control voltage transformers.
  - 7. If the Mechanical Contractor purchases equipment of larger horsepower than specified or shown on the plans, he shall pay all costs to increase the wiring and conduit.

### PART 3 - EXECUTION



3.1 APPLICATION

- A. Motors drawing less than 250 watts and intended for intermittent service may be germane to equipment manufacturer and need not conform to these specifications.
- B. Motors shall be open drip-proof type, except where specifically noted otherwise.
- C. Single phase motors for shaft mounted fans or blowers shall be permanent split capacitor type.

3.2 NEMA OPEN MOTOR SERVICE FACTORS

HORSEPOWER	3600 RPM	1800 RPM	1200 RPM	900 RPM
1/6-1/3	1.35	1.35	1.35	1.35
1/2	1.25	1.25	1.25	1.15
3/4	1.25	1.25	1.15	1.15
1	1.25	1.15	1.15	1.15

3.3 MOTOR EFFICIENCY

- A. Each motor furnished on the job must meet ASHRAE 90.1 and shall have a minimum guaranteed efficiency as listed in table below. Minimum guaranteed efficiencies for all motors shall be clearly stamped on motor nameplate. The lack of such stamp shall be cause for rejection of motor.

HORSEPOWER	EFFICIENCY
1, 1-1/2, 2	84.00
3	88.50
5, 7-1/2, 10	90.20
15, 20	91.70
25, 30, 40	93.00
50, 60, 75	94.10
100, 125, 150, 200	95.00

END OF SECTION 23 05 13

## SECTION 23 05 29 - SUPPORTS AND ANCHORS

### PART 1 - GENERAL

#### 1.1 WORK INCLUDED

- A. Pipe and equipment hangers, supports, and associated anchors.
- B. Equipment bases and supports.
- C. Sleeves and seals.
- D. Flashing and sealing equipment and pipe stacks.

#### 1.2 RELATED WORK

- A. Section 23 07 00 - Piping and Equipment Insulation.
- B. Section 23 21 13 - Hydronic Piping.

#### 1.3 SUBMITTALS

- A. Submit shop drawings and product data under provisions of Section 01 30 00 – Administrative Requirements.
- B. Indicate hanger and support framing and attachment methods.

### PART 2 - PRODUCTS

#### 2.1 ACCEPTABLE MANUFACTURER'S

- A. Fee and Mason
- B. Grinnel

#### 2.2 PIPE HANGERS AND SUPPORTS

- A. Hangers for pipe sizes 1/2 to 1-1/2 inch: Malleable iron, adjustable swivel, split ring.
- B. Hangers for pipe sizes 2 to 4 inches and cold pipe sizes 6 inches and over: Carbon steel, adjustable, clevis.
- C. Multiple or trapeze hangers: Steel channels with welded spacers and hanger rods; cast iron roll and stand for hot pipe sizes 6 inches and over.
- D. Vertical Support: Steel riser clamp.
- E. Floor support for pipe sizes 4 inches and over: Welded steel bracket and wrought steel clamp; adjustable steel yoke and cast iron roller for hot pipe 6 inches and over.

F. Shields for insulated piping 2 inches and smaller: 18 gauge galvanized steel shield over insulation in 180 degree segments, minimum 12 inches long at pipe support.

G. All hangers to be sized to include insulation.

## 2.3 HANGER RODS

A. Steel Hanger Rods: Threaded both ends, threaded one end, or continuous threaded.

## 2.4 INSERTS

A. Inserts: Malleable iron case or galvanized steel shell and expander plug for threaded connection with lateral adjustment, top slot for reinforcing rods, lugs for attaching to forms, size inserts to suit threaded hanger rods.

## 2.5 FLASHING

A. Metal Flashing: 26 gauge galvanized steel.

B. Lead Flashing: 5 lb./sq. ft. sheet lead for waterproofing.

C. Caps: Steel, 22 gauge minimum, 16 gauge at fire resistant elements.

## 2.6 SLEEVES

A. Sleeves for pipes through non-fire rated floors: Form with 18 gauge galvanized steel.

B. Sleeves for pipes through non-fire rated beams, walls, footings, and potentially wet floors: Form with steel pipe or 18 gauge galvanized steel.

## 2.7 FABRICATION

A. Size sleeves large enough to allow for movement due to expansion and contraction. Provide for continuous insulation wrapping.

B. Design hangers without disengagement of supported pipe.

## 2.8 FINISH

A. Prime coat exposed steel hangers and supports.

B. Protect against galvanic action with dielectric unions for dissimilar metals.

## PART 3 - EXECUTION

### 3.1 INSERTS

A. Provide inserts to General Contractor for placement in concrete formwork.

B. Provide inserts for suspending hangers from reinforced concrete slabs and sides of reinforced concrete beams.

- C. Provide hooked rod to concrete reinforcement section for inserts carrying pipe over 4 inches.
- D. Where concrete slabs form finished ceiling, provide inserts to be flush with slab surface.
- E. Where inserts are omitted, drill through concrete slab from below and provide thru-bolt with recessed square steel plate and nut recessed into and grouted flush with slab.

3.2 PIPE HANGERS AND SUPPORTS

- A. Support horizontal piping as follows:

PIPE SIZE DIAMETER	MAX HANGER SPACING	MIN. HANGER
1-1/2 TO 2 INCH	10' - 0"	3/8"
2-1/2 TO 3 INCH	10' - 0"	1/2"
4 to 6 inch	10' - 0"	5/8"
8 to 12 inch	10' - 0"	7/8"
14 to 20 inch	15' - 0"	1"

- B. Install hangers to provide minimum 1/2 inch space between finished covering and adjacent work.
- C. Place a hanger within 12 inches of each horizontal elbow.
- D. Use hangers with 1-1/2 inch minimum vertical adjustment.
- E. Where several pipes can be installed in parallel and at same elevation, provide multiple or trapeze hangers.
- F. Support riser piping independently of connected horizontal piping.

3.3 EQUIPMENT BASES AND SUPPORTS

- A. Provide equipment bases of reinforced concrete as detailed on plans.
- B. Provide templates, anchor bolts, and accessories for mounting and anchoring equipment.
- C. Provide rigid anchors for pipes after vibration isolation components are installed.

3.4 FLASHING

- A. Provide flexible flashing and metal counterflashing where piping and ductwork penetrate weather or waterproofed walls, floors, and roofs.

END OF SECTION 23 05 29

## SECTION 23 05 53 - MECHANICAL IDENTIFICATION

### PART 1 - GENERAL

#### 1.1 WORK INCLUDED

- A. Identification of all mechanical products installed under this Division.

#### 1.2 RELATED WORK

- A. Section 09 90 00 - Painting: Identification painting.

#### 1.3 REFERENCES

- A. ANSI/ASME A13.1 - Scheme for the Identification of Piping Systems.

#### 1.4 SUBMITTALS

- A. Submit product data under provisions of Section 01 30 00– Administrative Requirements.
- B. Mechanical and plumbing contractors shall coordinate color codes and marking procedures.

#### 1.5 APPROVAL OF PRODUCT PRIOR TO BIDDING

- A. Refer to Instructions to Bidders, Page IB-3, Paragraph 4.3 Substitution.

### PART 2 - PRODUCTS

#### 2.1 MATERIALS

- A. Color: Unless specified otherwise, conform with ANSI/ASME A13.1.
- B. Plastic Nameplates: Laminated three-layer plastic with engraved black letters on light contrasting background color.
- C. Metal Tags: Brass with stamped letters, tag size minimum 1-1/2 inch (38 mm) diameter with smooth edges.
- D. Stencils: With clean cut symbols and letters of following size:

OUTSIDE DIAMETER OF INSULATION OF PIPE	LENGTH OF COLOR FIELD	SIZE OF LETTERS
3/4" - 1-1/4"	8"	1/2"
1-1/2" - 2"	8"	3/4"

- E. Plastic Tape Pipe Markers: Flexible, vinyl film tape with pressure sensitive adhesive backing printed markings.

- F. Underground Plastic Pipe Markers: Bright colored continuously printed plastic ribbon tape of not less than 6" wide by 4 mil thick manufactured for direct burial service.

## PART 3 - EXECUTION

### 3.1 PREPARATION AND INSTALLATION:

- A. Degrease and clean surfaces to receive adhesive for identification material.

### 3.2 INSTALLATION

- A. Plastic Nameplates: Install with corrosive-resistant mechanical fasteners, or adhesive.
- B. Plastic Pipe Markers: Install in accordance with manufacturer's instructions.
- C. Plastic type Pipe Markers: Install complete around pipe in accordance with manufacturer's instructions.
- D. Underground Plastic Pipe Markers: Install 6 to 8 inches (150 to 200 mm) below finished grade, directly above buried pipe.
- E. Equipment: Identify air handling units, pumps, heat transfer equipment, tanks and water treatment devices, and motor starters with plastic nameplates. Small devices, such as in-line pumps, may identified with plastic tags.
- F. Controls: Identify control panels and major control components outside panels with plastic nameplates.
- G. Valves: Identify valves in main and branch piping with tags.
- H. Piping: Identify piping, concealed or exposed, with plastic pipe markers. Tags may be used on small diameter piping. Identify service and flow direction. Install in clear view and align with axis of piping. Locate identification not to exceed 20 feet on straight runs including risers and drops, adjacent to each valve and "T", at each side penetration of structure or enclosure, and at each obstruction.

### 3.3 PAINTING

- A. All surfaces requiring painting shall be left clean by the Mechanical Subcontractor. All painting shall be done by the General Contractor's painting Subcontractor. All exposed piping or insulation, convectors, grilles, or fans, in building or on roof will be painted. Paint pipe, equipment, hangers and accessories in Equipment Rooms including covering and foundations with two (2) coats of approved paint after thoroughly cleaning. Equipment having factory finish shall be touched up and given one (1) additional coat of machinery enamel color as selected. The above shall be done by the General Contractor. See Section 09 90 00.
- B. All piping in all equipment rooms shall be identified with pipe markers with directional arrows. The following color code shall be followed.

LEGEND	PIPING	DIRECTIONAL MARKER	BAND COLOR BACKGROUND
Domestic Water	Green	Green	White

NOTE: On any asphalt finished surfaces, prime with one (1) coat of aluminum paint before final color.

END OF SECTION 23 05 53

## SECTION 23 05 93 - TESTING, ADJUSTING, AND BALANCING

### PART 1 - GENERAL

#### 1.1 RELATED DOCUMENTS

- A. All division 23 specification sections, drawings, and general provisions of the contract apply to work of this section, as do other documents referred to in this section.

#### 1.2 SCOPE OF WORK

- A. The Contractor shall obtain the services of an independent Test and Balance (TAB) Company which specializes in the testing and balancing of heating, ventilating and air conditioning (HVAC) systems to test, adjust and balance all HVAC systems in the building(s).
- B. The work included in this section consists of furnishing labor, instruments, and tools required in testing, adjusting and balancing the HVAC systems as described in these specifications or shown on accompanying drawings. Services shall include checking equipment performance, taking the specified measurements, and recording and reporting the results. The testing, adjusting and balancing agency shall act as a reporting agency; that is, list and report each piece of equipment as to identification number, manufacturer, model number, serial number, proper location, specified performance, and report actual performance of all equipment as found during testing. The report is intended to be used during the life of the building as a ready reference indicating original conditions, equipment components, etc.
- C. Representatives of the Test and Balance Company shall visit the job site during installation of the HVAC equipment, piping and ductwork as required.
- D. Upon completion of the HVAC system installation, the Test and Balance Company shall perform all required testing and balancing with the full cooperation of the Contractor and his Sub-contractors. The Contractor shall make changes and/or adjustments to the HVAC system components that are required by the Test and Balance Company to accomplish proper balancing. The TAB agency shall not supply or install any materials or balancing devices such as pulleys, drives, belts, etc. All of this work is by the Contractor and shall be performed at no additional cost to the Owner.
- E. The test and balance report complete with a summary page listing all deficiencies shall be submitted to the Architect for review by his Mechanical Engineer. If the Mechanical Engineer agrees with the report, he shall sign it and return it to the Architect. The test and balance report must be complete and must be accepted by the Mechanical Engineer prior to acceptance of the project. Any outstanding test and balance items shall be placed on the punch list and a monetary value shall be assigned to them.
- F. After all deficiencies have been corrected the Mechanical Engineer shall sign the testing and balancing report, and the Test and Balance Company shall supply four (4) copies of the final and complete report to the Architect for inclusion in the Operation and Maintenance Manuals.



- G. The items requiring testing, adjusting, and balancing include (but are not restricted to) the following:
  - AIR SYSTEMS
  - Supply Fans
  - Zone, Branch, & Main Ducts
  - Diffusers, registers, & grilles
  - Coils

### 1.3 DEFINITIONS, REFERENCES, STANDARDS

- A. All work shall be in accordance with the latest edition of the Associated Air Balance Council (AABC) National Standards or the latest standards of the National Environmental Balancing Bureau (NEBB). If these contract documents set forth more stringent requirements than the AABC National Standards or the NEBB Standards, these contract documents shall prevail.

### 1.4 QUALIFICATIONS

- A. Agency Qualifications: The TAB Agency shall be a current member of the AABC or the NEBB and must be in good standing with FP&C. A list of these firms shall be obtained from FP&C. Falsification of a TAB report shall be grounds for removal from the FP&C list and the firm's actions shall be reported to the appropriate certification agency. The contractor may use any FP&C approved TAB firm on a state project.

### 1.5 SUBMITTALS

- A. Procedures and Agenda: The TAB agency shall submit the TAB procedures and agenda proposed to be used.
- B. Sample Forms: The TAB agency shall submit sample forms, which shall include the minimum data required by the AABC National Standards or the NEBB Standards.

### 1.6 TAB PREPARATION AND COORDINATION

- A. Shop drawings, submittal data, up-to-date revisions, change orders, fan curves, pump curves and other data required for planning, preparation, and execution of the TAB work shall be provided when available and no later than 30 days after the Designer has returned the final approved submittal data to the Contractor.
- B. System installation and equipment startup shall be complete prior to the TAB agency's being notified to begin.
- C. The building control system (BCS) contractor shall provide and install the control system, including all temperature, pressure and humidity sensors. These shall be calibrated for accurate control. If applicable, the BCS contractor shall install all necessary computers and computer programs, and make these operational. Assistance shall be provided as required for reprogramming, coordination, and problem resolution.
- D. All test points, balancing devices, identification tags, etc., shall be accessible and clear of insulation and other obstructions that would impede TAB procedures.
- E. Qualified installation or startup personnel shall be readily available for the operation and

adjustment of the systems. Assistance shall be provided as required for coordination and problem resolution.

## 1.7 REPORTS

- A. Final TAB Report - The TAB agency shall submit the final TAB report for review by the Architect. On plans provided, all outlets, devices, HVAC equipment, etc., shall be identified (including manufacturer, model number, serial number, motor manufacturer, HP, drive type, fan and motor sheaves and belt number), along with a numbering system corresponding to report unit identification. The TAB agency shall submit an AABC "National Project Performance Guaranty" (or similar NEBB Guaranty) assuring that the project systems were tested, adjusted and balanced in accordance with the project specifications and AABC National Standards (or similar NEBB Standards). The Designer shall certify his approval on the Performance Guaranty.
- B. Submit 4 copies of the Final TAB Report to the Architect for inclusion in the Operation and Maintenance Manuals.

## PART 2 - INSTRUMENTATION

- A. All instruments used for measurements shall be accurate and calibrated. Calibration and maintenance of all instruments shall be in accordance with the requirements of AABC National Standards (or similar NEBB Standards).

## PART 3 - EXECUTION

### 3.1 GENERAL

- A. The specified systems shall be reviewed and inspected for conformance to design documents. Testing, adjusting and balancing on each identified system shall be performed. The accuracy of measurements shall be in accordance with AABC National Standards (or similar NEBB Standards). Adjustment tolerances shall be + or - 10% unless otherwise stated.
- B. Equipment settings, including manual damper quadrant positions, valve indicators, fan speed control levers, and similar controls and devices shall be marked to show final settings.
- C. All information necessary to complete a proper TAB project and report shall be per AABC or NEBB standards unless otherwise noted. The descriptions of work required, as listed in this section, are a guide to the minimum information needed.
- D. TAB contractor shall cut insulation, ductwork and piping for installation of test probes to the minimum extent necessary to allow adequate performance of procedures. Upon completion, patch insulation, ductwork and housings using materials identical to those removed. Seal insulation to reestablish integrity of the vapor barrier.
- E. TAB work shall include additional inspection and adjustment of components during the season following the initial balance to include re-balance of any items influenced by

seasonal changes or as directed by the Owner.

### 3.2 AIR SYSTEMS

- A. The TAB agency shall verify that all ductwork, splitters, extractors, dampers, grilles, registers, and diffusers have been installed per design, are functional and set full open. Any leakage in the ductwork shall be repaired prior to the test. The TAB agency shall perform the following TAB procedures in accordance with the AABC National Standards or NEBB Standards:

For supply fans:

1. Fan speeds - Test and adjust fan RPM to achieve design CFM requirements.
2. Current and Voltage - Test and record motor voltage and amperage, and compare data with the nameplate limits to ensure fan motor is not in or above the service factor.
3. Pitot-Tube Traverse - Perform a Pitot-tube traverse of main supply and return ducts, as applicable to obtain total CFM. If a Pitot-tube traverse is not practical, an explanation of why a traverse was not made must appear on the appropriate data sheet.
4. Outside Air - Test and adjust the outside air on applicable equipment using a Pitot-tube traverse. If a traverse is not practical, an explanation of why a traverse was not made must appear on the appropriate data sheet. If a traverse is not practical use the mixed-air temperature method if the inside and outside temperature difference is at least 20 degrees Fahrenheit or use the difference between Pitot-tube traverses of the supply and return air ducts.
5. Static Pressure - Test and record system static pressure, including the static pressure profile of each supply fan.

For exhaust fans:

1. Fan speeds - test and adjust fan RPM to achieve design CFM requirements.
2. Current and Voltage - Test and record motor voltage and amperage, and compare data with the nameplate limits to ensure motor is not in or above the service factor.
3. Pitot-Tube Traverse - Perform a Pitot-tube traverse of main exhaust ducts to obtain total CFM. If a Pitot-tube traverse is not practical, an explanation of why a traverse was not made must appear on the appropriate data sheet.
4. Static Pressure - Test and record system static pressure, including the static pressure profile of each exhaust fan.

For zone, branch and main ducts:

1. Adjust ducts to within design CFM requirements. As applicable, at least one zone balancing damper shall be completely open. Multi-diffuser branch ducts shall have at least one outlet or inlet volume damper completely open.

For diffusers, registers and grilles:

1. Tolerances - Test, adjust, and balance each diffuser, grille, and register to within 10% of design requirements. Minimize drafts. Include required CFM, initial test CFM and final CFM.
2. Identification - Identify the type, location, and size of each grille, diffuser, and register. This information shall be recorded on air outlet data sheets.

For coils:

1. Air Temperature - Once air flows are set to acceptable limits, take wet bulb and dry

bulb air temperatures on the entering and leaving side of each cooling coil. Dry-bulb temperature shall be taken on the entering and leaving side of each heating coil.

For coils:

1. Tolerances - Test, adjust, and balance all chilled-water and hot-water coils within 10% of design requirements.
2. Verification - Verify the type, location, final pressure drop and GPM of each coil. This information shall be recorded on coil data sheets.

### 3.3 ADDITIONAL TAB SERVICES

- A. Job Site Inspections: During construction, the TAB agency shall inspect the installation of pipe systems, sheet metal work, temperature controls, and other component parts of the HVAC systems as required.
- B. Verification of HVAC Controls: The TAB agency shall be assisted by the building control systems Contractor in verifying the operation and calibration of all HVAC and temperature control systems. The following tests shall be conducted:
  1. Verify that all control components are installed in accordance with project requirements and are functional, including all electrical interlocks, damper sequences, air and water resets, fire and freeze stats, and other safety devices.
  2. Verify that all controlling instruments are calibrated and set for design operating conditions.
- C. Temperature Testing: To verify system control and operation, a series of three temperature tests shall be taken at approximately two hour intervals in each separately controlled zone. The resulting temperatures shall not vary more than two degrees Fahrenheit from the thermostat or control set point during the tests. Outside temperature and humidity shall also be recorded during the testing periods.
- D. TAB Report Verification: At the time of final inspection, the TAB agency may be required to recheck, in the presence of the owner's representative, specific and random selections of data, air quantities, and air motion recorded in the certified report. Points and areas for recheck shall be selected by the owner's representative. Measurements and test procedures shall be the same as approved for the initial work for the certified report. Selections for recheck, specific plus random, will not exceed 10% of the total number tabulated in the report.

END OF SECTION 23 05 93

## SECTION 23 07 00 - PIPING AND EQUIPMENT INSULATION

### PART 1 - GENERAL

#### 1.1 WORK INCLUDED

- A. Piping Insulation
- B. Jackets and Accessories
- C. Equipment Insulation
- D. Duct Insulation

#### 1.2 RELATED WORK

- A. Section 23 31 00 - Ductwork

#### 1.3 REFERENCES

- A. ANSI/ASTM C547 - Mineral Fiber Preformed Pipe Insulation
- B. ANSI/ASTM C552 - Cellular Glass Block and Pipe Thermal Insulation.
- C. ASTM B209 - Aluminum and Aluminum Alloy Sheet and Plate
- D. ASTM E845 - Surface Burning Characteristics of Building Materials.
- E. NFPA 255 - Surface Burning Characteristics of Building Materials.
- F. UL 723 - Surface Burning Characteristics of Building Materials.

#### 1.4 QUALITY ASSURANCE

- A. Applicator: Company specializing in application of piping insulation.
- B. Materials: Flame spread/fuel contributed/smoke developed rating of 25/50/50 in accordance with ASTM E84, NFPA 255.0, UL 723.

#### 1.5 SUBMITTALS

- A. Submit product data for each application as per Section 01 30 00– Administrative Requirements.
- B. Submit manufacturer's installation instructions.

### PART 2 - PRODUCTS

#### 2.1 INSULATION

- A. After all work has been tested and found to be leak free and tight, and accepted by the Architect, insulate as follows:
1. All domestic hot and cold piping above ground shall be covered with 1" thick fiberglass, molded type sectional pipe covering complete with FRJ jacket. Sections of pipe covering shall be joined together, the mastic to be buttered on only one of the two adjoining surfaces at both the Longitudinal and circumferential joints so that a complete seal at the joints is obtained. The piping insulation will be secured in place with copper wire spaced not more than 12 on center. All domestic water piping insulation shall be continuous. Contractor shall not cut insulation to fit around structural items. No exceptions.
  2. Insulate the square to round connections on each air handling unit with 3" thick 3/4 lb. density insulation board using stick pins randomly spaced 18" apart. Insulation board shall have aluminum vapor barrier.
  3. Fittings, flanges, valves, etc., shall be covered with molded or fabricate covers of same material as pipe covering and shall be finished with two (2) coats of white vapor barrier mastic reinforced with 20-20 mesh glass fabric.
  4. Insulate rectangular supply, return, exhaust, and fresh air ducts with 3" thick 3/4 lb. density fiberglass insulation with reinforced aluminum vapor barrier. Seal all joints with duct tape.
  5. All round and flat oval supply air ducts shall be wrapped with 3" thick, 3/4 lb. density fiberglass insulation with reinforced aluminum vapor barrier. Seal all joints with 2" duct tape.
  6. Insulate cooling coil condensate drain lines from air handling units with 1/2" thick aerotube type insulation tied on and sealed over with tape.
  7. Insulate back of all ceiling diffusers with 3" thick fiberglass with reinforced aluminum vapor barrier.
  8. All outdoor mechanical piping shall be covered with aluminum jacket, water tight.
  9. All older duct work shall be covered with aluminum jacket, water tight.
  10. All external duct work must be externally insulated and double wall. Seal water tight.
  11. All exterior ductwork and ductwork run in attic spaces shall be wrapped with 3" thick, 3/4 lb. density fiberglass insulation with reinforced aluminum vapor barrier.
  12. Insulate all PVC piping located in a return air plenum with 2" thick 3/4 lb. density fiberglass insulation with reinforced aluminum vapor barrier. Seal all joints with duct tape.

## PART 3 - EXECUTION

### 3.1 PREPARATION

- A. Install materials in accordance with manufacturer's instructions.

### 3.2 INSTALLATION

- A. Install materials in accordance with manufacturer's instructions.
- B. Continue insulation with vapor barrier through penetrations.
- C. On insulated piping with vapor barrier, insulate fittings, valves, unions, flanges, strainers, flexible connections, and expansion joints.

- D. Neatly finish insulation at supports, protrusions, and interruptions.

END OF SECTION 23 07 00

## SECTION 23 31 00 - DUCTWORK

### PART 1 - GENERAL

#### 1.1 WORK INCLUDED

- A. Low pressure duct.
- B. Fire and Smoke Dampers

#### 1.2 RELATED WORK

- A. Section 23 05 23 - Supports and Anchors
- B. Section 23 07 00 - Piping and Equipment Insulation
- C. Section 23 36 00 - Air Terminal Units
- D. Section 23 37 00 - Air Inlets and Outlets
- E. Section 23 05 93 - Testing and Balance

#### 1.3 REFERENCES

- A. ASHRAE, 2009 Fundamentals, Chapter 21.
- B. ASHRAE, 2008 Equipment, Chapter 18.
- C. NFPA 90A, 90B.
- D. H.V.A.C. Duct Construction Standards - SMACNA 1995.

#### 1.4 DEFINITIONS

- A. Duct sizes: Inside clear dimensions for wrapped ducts, maintain sizes inside lining. Metal to metal sizes for internally lined ductwork.
- B. Low Pressure: Three pressure classifications: 1/2" WG positive or negative static pressure and velocities less than 2,000 fpm, 1" WG positive or negative static pressure and velocities less than 2,500 fpm and 2" WG positive or
- C. Medium Pressure: Three pressure classifications: 3 inch WG positive or negative static pressure and velocities less than 4,000 fpm, 4" WG positive static pressure and velocities greater than 2,000 fpm. 6" WG positive static pressure and velocities greater than 2,000 fpm.

#### 1.5 REGULATORY REQUIREMENTS

- A. Construct ductwork to NFPA 90A and NFPA 90B Standards.



- B. Store and protect products under provisions of Section 01 60 00.
- C. Construct ductwork to International Mechanical Code Standards

## PART 2 - PRODUCTS

### 2.1 LOW PRESSURE DUCTWORK

- A. Furnish and install all ducts for the air conditioning, heating and ventilating systems. Ductwork shall be complete with grilles, vanes splitters, flashings, hangers, flexible connections, manual dampers, fresh air inlet louvers, reinforcing angles, transitions to equipment, etc.
- B. All low pressure ductwork (mean velocity less than 2,000 FPM and static pressure in duct 2" of water or less) shall be constructed as per SMACNA Standards, 1995 Edition, Chapter 1, and shall be of the gauge metal and reinforced as per SMACNA Standards, 1995 Edition.
- C. Flashing shall be of the same material as specified under the roofing and flashing section of these specifications, or of 16-ounce sheet copper and shall be furnished and installed around all outside openings used for ducts or fans where required. Roof flashing shall extend at least 8" above roof. Cooperate with roofing contractor when installing flashing.
- D. All duct connections to equipment shall be made with fire and mildew resistant flexible connections of canvas or other acceptable materials. Connections shall have suitable metal collar frames at each end and shall not be less than 4" long with at least 1" of slack in the connection. Flexible connections shall be heat resistant to 500 degrees F continuously.
- E. Duct dimensions shown are metal sizes. All edges shall be straight and true.
- F. All flexible connections, duct liner and adhesives shall be U.L. listed as having a maximum flame spread of 50, fuel contribution of 25 and smoke contribution of 25.
- G. This Contractor shall furnish and install in ductwork all dampers, vanes splitters, etc.. as shown on the drawings or necessary to make the system complete. Where dampers or splitters can not be accessed through lay in ceiling, Contractor shall provide lockable 24" x 24" access door. Contractor shall coordinate location with Architect.
- H. Shafts shall be marked to show position of dampers, vanes, splitters, etc.
- I. Ductwork shall be supported in accordance with SMACNA Plate No. 17 and No. 18, up to and including band iron hangers attached to duct by means of screws or rivets per hanger.
- J. Access doors shall be provided in ductwork for all automatic dampers and each manual damper 3 square feet in area or larger, and shall be so located that damper can be completely serviced through the access door. Access door shall be provided with felt gaskets and suitable hinges and locks. Where access doors occur in insulated duct, double skin insulated doors shall be used.
- K. Where square ducts are shown, provide single vane elbows as per Plate 22, Figure A,

SMACNA Standards, 1995 Edition. For all ductwork over 18" provide double vane square elbow as shown in Figure C of the Plate.

- L. All low pressure ductwork joints shall be sealed with hard cast "iron grip".
- M. Flexible air duct for connections between low pressure rectangular duct and ceiling diffusers shall be pre- insulated and listed by Underwriters Laboratories under U.L Standard 181 as a Class 1 flexible air duct and complying with NFPA Standards 90A and 90B.
- N. All flex duct 45 degree and 90 degree turns shall be metal hard duct.

2.2 INSULATED ACOUSTICAL LOW PRESSURE FLEXIBLE DUCT

- A. The duct shall be constructed of a CPE fabric supported by helical wound galvanized steel.
- B. Provide where indicated on drawings Flexmaster or Thermaflex Air Duct.
- C. Fabric shall be mechanically locked to the steel helix without the use of adhesives or chemicals.
- D. The internal working pressure rating shall be at least 6" w.g. positive and 4" w.g. negative with a bursting pressure of at least 2½ time the working pressure.
- E. The duct shall be rated for a velocity of at least 4000 feet per minute.
- F. The duct must be suitable for continuous operation at a temperature range of -20° F to +250°
- G. Acoustical performance, when tested by an independent laboratory in accordance with the Air Diffusion Council's Flexible Air Duct Test Code FD 72-R1, Section 3.0, Sound Properties, shall be as follows:

The insertion loss (dB) of a 10 foot length of straight duct when tested in accordance with ASTM 477, at a velocity of 2500 feet per minute, shall be at least:

Octave Band	2	3	4	5	6	7
Hz.	125	250	500	1000	2000	4000
6" diameter	7	31	40	38	40	27
8" diameter	13	29	36	35	38	22
12" diameter	21	28	29	33	26	12

The radiated noise reduction (dB) of a 10 foot length of straight duct when tested in accordance with ASTM E477, at a velocity of 2500 feet per minute, shall be at least:

Octave Band	2	3	4	5	6	7
-------------	---	---	---	---	---	---

Hz.	125	250	500	1000	2000	4000
6" diameter	5	8	7	8	11	15
8" diameter	10	7	7	8	10	13
12" diameter	9	6	6	5	9	13

The self generated sound power levels (LW) dB re 10<sup>-12</sup> Watt of a 10 foot length of straight duct for an empty sheet metal duct when tested in accordance with ASTM E477, at a velocity of 1000 feet per minute, shall not exceed:

Octave Band	2	3	4	5	6	7
Hz.	125	250	500	1000	2000	4000
6" diameter	42	31	23	18	17	21
8" diameter	41	34	27	19	18	21
12" diameter	54	45	38	31	27	23

Factory insulate the flexible duct with fiberglass insulation. The R value shall be at least 5.0 at a mean temperature of 75° F. (R-4.2 is not acceptable)

- H. Cover the insulation with a fire retardant metalized vapor barrier jacket reinforced with crosshatched scrim having a permeance of not greater than 0.05 perms when tested in accordance with ASTM E96, Procedure A.
- I. Maximum length to be 3'-0

ALL FLEX CONNECTIONS TO CEILING DIFFUSERS MUST BE FACTORY DESIGNED TO HAVE NO DIMENSIONAL CONTORTION WHEN CONNECTED TO THE DIFFUSER.

### 2.3 FIRE AND SMOKE DAMPERS

- A. Round and oval fire dampers shall be designed for high pressure duct systems.
- B. Rectangular fire dampers shall be designed for low pressure duct systems.
- C. All fire dampers must be NFPA 90A and UL approved.
- D. Furnish and install access doors in ductwork, walls, and ceilings where required to service all fire dampers, smoke dampers and detectors. All fire and smoke dampers shall be installed by the sheet metal contractor. All smoke detectors shall be furnished by the electrical Sub-contractor. Control of smoke dampers shall be coordinated with fire alarm system and building automation system.

- E. Rectangular Smoke Dampers - Louvers Dampers Inc. Model SD-400-UD or Ruskin FSD-35 tight seal parallel blade smoke dampers with low leakage and felted blades.
- F. Round and Oval Smoke Dampers - Shall be same as above but complete with welded round or oval collars. Units shall be capable of handling pressures up to 6" W.G.
- G. Smoke dampers shall be Class I rated as per UL 555.
- H. Sheet metal contractor shall provide and install all smoke dampers and actuators. Dampers shall be provided with end switches
- I. Approved Manufacturers: Pottorff, Ruskin, Price, Nailor Industries, Greenheck, or prior approved equal.

#### 2.4 LOW LOSS TAP

- A. All round low pressure connections to rectangular ducts shall be made with a factory fabricated 45 degree low loss entry "shoe" tap with damper constructed of minimum 26 gage galvanized steel. The damper shall have a 2" raised handle with a high quality locking quadrant. A 3/8" continuous rod with "U" bolts connects the damper to the rod. Nylon end bearings are required where the rod penetrates the spin collar barrel.
- B. Provide Flexmaster #STOD-BO3, Dace # 26 ga STOD-C03, or prior approved equal.
- C. For medium pressure systems where used upstream of VAV terminals, the damper can be eliminated (use Flexmaster #STO or Dace 24 ga STO). Gauge shall be 24 gauge on medium pressure systems.

### PART 3 - EXECUTION

#### 3.1 INSTALLATION

- A. See details of ductwork symbols and connections on drawing.

END OF SECTION 23 31 00

## SECTION 23 34 10 - GENERAL EXHAUST SYSTEM

### PART 1 - GENERAL

#### 1.1 SCOPE

- A. This Section includes general and exhaust fans with accessories.

#### 1.2 RELATED DOCUMENTS

- A. Drawings and general provisions of Contract, including General and Supplementary Conditions and Division 1 Specification Sections, apply to this Section.
- B. Requirements of the following Division 23 Sections apply to this section:
  - 1. "BASIC MECHANICAL REQUIREMENTS."
  - 2. "BASIC MATERIALS AND METHODS."
  - 3. "ELECTRICAL REQUIREMENTS FOR MECHANICAL EQUIPMENT."
- C. Related Sections: The following sections contain requirements that relate to this section:
  - 1. Division 23, Section 23 05 93 "TESTING, AND BALANCING" for air-handling systems testing, adjusting, and balancing requirements and procedures.
  - 2. Division 23 Section 23 09 00 - CONTROLS

#### 1.3 SUBMITTALS

- A. Submit shop drawings and product data under provisions of Section 01 33 00.
- B. Product data for selected models, including specialties, accessories, and the following:
  - 1. Fan performance curves with system operating conditions indicated.
  - 2. Fan sound power ratings.
  - 3. Motor ratings and electrical characteristics plus motor and fan accessories.
  - 4. Materials gages and finishes.
  - 5. Dampers, including housings, linkages, and operators.
- C. Shop drawings from manufacturer detailing equipment assemblies and indicating dimensions, weights, required clearances, components, and location and size of field connections.
- D. Maintenance data for inclusion in Operating and Maintenance Manual.

#### 1.4 QUALITY ASSURANCE

- A. NEMA Compliance: Motors and electrical accessories shall comply with NEMA standards.
- B. Electrical Component Standard: Components and installation shall comply with NFPA 70 "National Electrical Code."

### PART 2 - PRODUCTS

## 2.1 MANUFACTURERS

- A. Certain items in this Specification are listed by manufacturer and/or manufacturer's model number to establish general style, type, character, and quality or product desired. Similar items manufactured by other than those listed will be considered, providing submittals are made according to Pre-Bid approval requirements of Instruction to Bidders.
- B. Where no manufacturer or model number are given, any product meeting performance or design criteria, or referenced trade association standard may be used and Pre-Bid Approval is not required.

## 2.2 MANUFACTURERS

- A. Manufacturers: Subject to compliance with requirements, provide products by one of the following:
  - 1. General Exhaust Fans:
    - a. Greenheck GB Series
    - b. Acme PL Series
    - c. PENN/Barry
    - d. Twin City
  - 2. Fume Hood Exhaust Fans:
    - a. Strobic Air Tri Stack Series
    - b. MK Plastics AXIJET

## 2.3 SOURCE QUALITY CONTROL

- A. Testing Requirements: The following factory tests are required:
  - 1. Sound Power Level Ratings for General Exhaust Fans: Comply with AMCA Standard 301 "Method for Calculating Fan Sound Ratings From Laboratory Test Data." Test fans in accordance with AMCA Standard 300 "Test Code For Sound Rating." General exhaust fans shall be licensed to bear the AMCA Certified Sound Ratings Seal.
  - 2. Fan Performance Ratings: Establish flow rate, pressure, power, air density, speed of rotation, and efficiency shall be factory tested and ratings in accordance with AMCA Standard 210/ASHRAE STANDARD.

## 2.04 DIRECT AND BELTED SPUN ALUMINUM POWER ROOF VENTILATORS

- A. General Description:
  - 1. Direct Drive: Roof exhaust fans shall be centrifugal direct drive type.
  - 2. The fan wheel shall be centrifugal backward incline, constructed of aluminum and shall include a wheel cone carefully matched to the inlet cone for precise running tolerances. Wheels shall be statically and dynamically balanced.
  - 3. The fan housing and schroud shall be constructed of heavy gauge aluminum with a ridged internal support structure. The fan shroud shall have a rolled bead for added strength.
  - 4. Motors shall be out of the air stream on vibration isolators. Fresh air for motor cooling shall be drawn into the motor compartment from an area free of discharge contaminants. Motors shall be readily accessible for maintenance.
  - 5. A disconnect switch shall be factory installed and wired from the fan motor to a junction box within the motor compartment. A conduit chase shall be provided

through the curb cap to the motor compartment for ease of electrical wiring.

B. GENERAL DESCRIPTION: Belt Drive

1. Belt Drive Centrifugal Roof Exhausters shall have centrifugal forwardly inclined wheels, constructed of aluminum and shall include a wheel cone carefully matched to the inner cone for precise tower running. Wheels shall be statistically and dynamically balanced.
2. The fan housing shall be constructed of heavy gauge aluminum with a rigid internal support structure. The fan schroud shall have a rolled beam for added strength.
3. Motors shall be heavy duty ball bearing type carefully matched to the fan mode and furnished at the specified voltage, phase and enclosure. Motors and drive shall be mounted on vibration isolators, out of the air stream. Fresh air for motor shall be drawn in the motor compartment from an area free of discharge contaminants. Motors shall be accessibly for maintenance.
4. Drive frame assembly shall be constructed of heavy gauge steal and mounted on vibration isolators
5. Precision ground and polished fan shafts shall be mounted in permanently sealed, lubricated pillow block ball bearings. Bearings shall be selected for a minimum (L50) life in excess of 200,000 hours at maximum catalog operating speed.
6. Drives shall be sized for a minimum of 150% of driven horsepower. Pulleys shall be of the fully matched cast iron type, keyed and securely attached to the wheel and motor shaft. Motor pulleys shall be adjustable for final system balance.
7. A disconnect switch shall be factory installed and wired from the fan motor to a junction box installed within the motor compartment. A fan conduit chase shall be provided through the curb cap to the motor compartment for ease of installation.
8. All fans shall bear AMCA Certified Ratings Seal for sound and air performance.
9. Each fan shall bear a permanently affixed manufacturer's name plate containing the model number and individual serial number for future identification.

END OF SECTION 23 34 10

## SECTION 23 37 00 - AIR OUTLETS AND INLETS

### PART 1 - GENERAL

#### 1.1 WORK INCLUDED

- A. Diffuser boots.
- B. Registers/grilles.
- C. Louvers.

#### 1.2 RELATED WORK

- A. See Mechanical Plans for wall louvers.

#### 1.3 REFERENCES

- A. ADC 1062 - Certification, Rating and Test Manual.
- B. AMCA 500 - Test Method for Louvers, Dampers, and Shutters.
- C. ANSI/NFPA 90A - Installation of Air Conditioning and Ventilating Systems.
- D. ARI 650 - Air Outlets and Inlets.
- E. ASHRAE 70 - Method of Testing for Rating the Air Flow Performance of Outlets and Inlets.
- F. SMACNA - Low Pressure Duct Construction Standard.

#### 1.4 QUALITY ASSURANCE

- A. Test and rate performance of air outlets and inlets in accordance with ADC Equipment Test Code 1062 and ASHRAE 70.
- B. Test and rate performance of louvers in accordance with AMCA 500.

#### 1.5 REGULATORY REQUIREMENTS

- A. Conform to ANSI/NFPA 90A.

#### 1.6 SUBMITTALS

- A. Submit shop drawings and product data under provisions of Section 01 30 00– Administrative Requirements.
- B. Provide product data for items required for this project.
- C. Submit schedule of outlets and inlets indicating type, size, application, and noise level.
- D. Review requirements of outlets and inlets as to size, finish, and type of mounting prior to



submitting product data and schedules of outlets and inlets.

- E. Submit diffuser, grille and register color data to Architect for approval.

## PART 2 - PRODUCTS

### 2.1 GENERAL

- A. See mechanical schedules and drawings for diffuser types, sizes and configuration. See architectural plans - room finish schedules for type of ceiling and wall construction.
- B. Substitutions: Under provisions of Instructions To Bidders, Page IB-3, Paragraph 4.3.

### 2.2 ACCEPTABLE MANUFACTURERS - Ceiling Diffusers

- A. Titus TMSA Series, Krueger Series 1400 Adjustable
- B. All diffusers shall have opposed blade volume dampers and adjustable horizontal to vertical four way throw operable from face of grille. All diffusers must be aluminum.

### 2.3 ACCEPTABLE MANUFACTURERS - Ceiling Exhaust Grilles

- A. Titus - Model 50F Code C 1/2" x 1/2" x 1" Cube Core, Krueger EGC-10, Nailor Industries Model 51EC
- B. All exhaust registers shall have opposed blade dampers.
- C. Grilles shall have baked enamel white finish.
- D. All dampers shall be operable from grille face.

### 2.4 ACCEPTABLE MANUFACTURERS - Ceiling Return Air Grilles

- A. Titus - 50F Code C, Krueger EGC-10, Nailor Industries
- B. All return air shall have opposed blade dampers. See plans for filter backed grille requirements.

### 2.5 ACCEPTABLE MANUFACTURERS - Wall Supply Registers.

- A. Titus 1700 Series, Krueger ULTRA-FLO
- B. All registers shall have adjustable blade dampers on all registers.
- C. Furnish and install opposed blade damper on all registers.
- D. Finish to be approved by Architect.

### 2.6 ACCEPTABLE MANUFACTURERS - DOOR RETURN GRILLES

- A. Titus Model CT-700, Krueger Series 5600, Nailor Industries

- B. Substitutions: Under provisions of Instructions To Bidders, Page IB-3, Paragraph 4.3.
- C. All aluminum construction & design.
- D. Finish to be approved by Architect.

### PART 3 - EXECUTION

#### 3.1 INSTALLATION

- A. Install items in accordance with manufacturer's instructions.
- B. Check location of outlets and inlets and make necessary adjustments in position to conform with architectural features, symmetry, and lighting arrangement. Refer to Section 09 90 00.
- C. Install diffusers to ductwork with air tight connection.
- D. Provide balancing dampers on duct take-off to diffusers, and grilles and register, regardless of whether dampers are specified as part of the diffuser, or grille and register assembly.
- E. Furnish and install necessary frames, bucks, sponge rubber gasketed, etc. to make a neat setting job.
- F. Diffusers shall be placed to insure that air does not blast against columns and lights.
- G. All diffusers, registers, etc. shall have external volume controls and deflecting grids.
- H. Ceilings in areas where plaster or gypsum board ceiling are used, shall be surface mounted.

END OF SECTION 23 37 00

## SECTION 26 01 00 - BASIC ELECTRICAL REQUIREMENTS

### PART 1 - GENERAL

#### 1.1 SCOPE

- A. The scope of work is as indicated on electrical drawings and includes but is not limited to the following:
- B. Demolition:
  - 1. Disconnect and remove all interior lighting fixtures and associated controls in areas of work.
  - 2. Disconnect and remove existing fire alarm system and peripheral devices areas of work.
  - 3. Disconnect existing mechanical and plumbing equipment for removal by others areas of work.
- C. Power:
  - 1. Provide branch circuits associated with all mechanical and plumbing system equipment, including all accessories such as motorized dampers, valves, fan interlocks, ionization, etc.
- D. Lighting:
  - 1. Provide interior light fixtures, wall switches, wall dimmers, and occupancy sensors and associated branch circuits.
  - 2. Provide exit light fixtures and both interior and exterior emergency light fixtures as required by NFPA 101, National Electrical Code (NEC), and IBC.
- E. Fire Alarm:
  - 1. Provide visual and audio notification in each area as required by NFPA 101 & NFPA 72.

#### 1.2 GENERAL CONDITIONS

- A. The General Conditions and Supplementary General Conditions are a part of this section of these Specifications. The Contractor is cautioned to read and be thoroughly familiar with all provisions of the General Conditions. These conditions shall be complied with in every aspect.

#### 1.3 DEFINITIONS:

- A. The word "shall" where used, is to be understood, as mandatory and the word "should" as advisory. "May" is used in the permissive sense.
- B. Concealed: Concealed areas are those areas that cannot be seen by building occupants.
- C. Exposed: Exposed areas are all areas that are exposed to view by building occupants, including areas below counter tops, inside cabinets and closets, inside all equipment

rooms, and areas outside the building exterior envelope.

- D. Feeder: Feeder consists of both conduit and wiring installed above or below grade
- E. Provide: Provide shall including furnishing, installing, and connecting the item or items referenced unless specifically indicated otherwise.

#### 1.4 QUALITY ASSURANCE

##### A. General:

1. Every effort has been made by the Engineer to clearly indicate all devices/equipment requiring an electrical/data connection. It is the intent of the Engineer that all light fixtures be powered and controlled, that all devices and equipment be circuited to a panelboard of appropriate voltage and breaker of MOCP not exceeding manufacturer's specifications. That all communications, security, and fire alarm devices are installed, wiring, and functioning properly.
  2. Where there is a conflict between the contract document and an applicable Code. The Code shall govern except where the requirements of the contract documents are more stringent. The most stringent requirement shall apply.
  3. All work shall be concealed unless specifically noted to be exposed.
  4. Coordinate the exact locations of electrical outlets and equipment with building features and equipment as indicated on architectural, structural, mechanical, plumbing, landscape, and food service drawings. Review any/all proposed changes in electrical device/equipment locations with Architect prior to rough-in. Architect may direct relocation of outlets before rough-in, up to ten (10) feet from the position indicated, without additional cost. Remove and relocate outlets placed in unsuitable locations when requested by the Architect, at no additional cost.
  5. Resolve, in writing, any code violation discovered in contract documents with the Engineer prior to bidding. After award of the contract, Contactor shall make any correction or addition necessary for compliance with applicable codes at no additional cost.
- B. An approved contractor for the work under this division shall be:
1. A licensed electrical contractor in the jurisdiction in which the work shall be performed.
  2. Able to furnish evidence of having contracted for and installed not less than three (3) systems of comparable size and type that have served their Owners satisfactorily for no less than three (3) years.
- C. All work, materials and equipment shall comply with the latest applicable codes, local ordinances, and UL requirements.
- D. Provide new products of manufacturers regularly engaged in production of such equipment. Provide the manufacturer's latest standard design for the type product specified. All new products shall be listed for the use shown on drawings.
- E. Equipment shall be delivered with a factory-applied finish so that no additional field painting is required.
- F. Equipment shall be selected to conform the building space limitations. Do not provide equipment that cannot meet the arrangement requirements shown on plans. Contractor

shall submit room layouts with submitted items shown drawn to scale. Submittals will be rejected without floor plan Drawings showing submitted items.

- G. All equipment included in the service and distribution specifications shall be provided by the same manufacturer.
- H. Manufacturer names and model numbers are subject to change. Contractor shall verify them with manufacturer's representative prior to ordering any product or equipment.

#### 1.5 GENERAL REQUIREMENTS

- A. The Contractor is referred to all of the Drawings for building construction as well as the electrical Drawings.
- B. The Contractor shall examine the site and shall verify to his own satisfaction the location of all utilities, and shall adequately inform himself as to their relation to his work before entering into a Contract and he shall base his bid on any conditions, which may be encountered during the progress of the work.
- C. The Contractor shall furnish and install properly all materials, devices, equipment, supports, controls, appurtenances, etc., mentioned or required to make complete or satisfactory installations in working order whether shown or not. All electrical equipment shall be connected in accordance with manufacturer's instructions. All work shall be executed in a workmanlike manner and shall present a neat and mechanical appearance when completed.
- D. The Contractor shall provide finished to match approved samples; all exposed finishes shall be approved by the Architect. Submit color samples as required.

#### 1.6 APPLICABLE GENERAL CODES AND REGULATIONS

- A. All electrical work and equipment, in whole or in part, shall conform to the applicable portions of the following specifications, codes and regulations in effect on that date of invitation for bids, and shall form a part of this specification.
- B. The latest published edition of a reference shall be applicable to this Project unless identified by a specific edition.
- C. All reference amendments adopted prior to the effective date of this Contract shall be applicable to this Project.
  - 1. NFPA 70, National Electrical Code
  - 2. National Fire Codes:
    - a. NFPA 70E, Electrical Safety Requirements for Employee Workplaces
    - b. NFPA 72, National Fire Alarm Code
    - c. NFPA 77, Static Electricity
    - d. NFPA 99, Health Care Facilities
    - e. NFPA 101, Life Safety Code
    - f. NFPA 110, Emergency and Standby Power Systems
  - 3. Occupational Safety and Health Regulations (OSHA).
  - 4. NFPA Standards in effect shall be as listed or adopted by the appropriate authority having jurisdiction.

5. American National Standards Institute (ANSI)
6. Institute of Electrical and Electronics Engineers (IEEE)
7. Local, City and State Codes and Ordinances
8. Regulations and standards of the Electric Utility Company
9. National Electrical Safety Code (NESC)
10. National Electrical Manufacturers Association (NEMA)
11. Insulated Power Cable Engineers Association (IPCEA)
12. International Building Codes (IBC)
13. International Energy Conservation Codes (IECC)

- D. Equipment that has been inspected and approved by the Underwriter's Laboratory shall bear its label or appear on its list of approved apparatus.

#### 1.7 DRAWINGS

- A. Plans and detail sketches are submitted to limit, explain, and define conditions, specified requirements, conduit sizes, and manner of erecting work. The Contractor is cautioned to field check and verify all existing conditions before bidding, as no extra compensation will be allowed for conditions found different than represented in the construction drawings and/or specifications. Written approval of the Architect shall be obtained prior to any alterations or additions to specified work.
- B. Structural or other conditions may require certain modifications from the manner of installation shown, and such deviations are permissible and shall be made as required, but specified sizes and requirements necessary for satisfactory operations shall remain unchanged.
- C. The drawings and these specifications are complementary to each other and what is called for by one shall be binding as if called for by both.
- D. General arrangement of work is indicated on plans. Due to the small scale of the drawings, offsets, fittings, and boxes required are not all indicated; provide fittings, boxes, etc., as needed in accordance with codes and accepted practices.

#### 1.8 SUPERVISION

- A. The Contractor shall personally or through an authorized and competent representative, constantly supervise the work from beginning to completion and final acceptance. So far as possible, he shall keep the same foreman and workmen throughout the project duration.
- B. During its progress, the work shall be subject to inspection by representatives of the Architect or Engineer, at which times the Contractor shall furnish required information.
- C. It is not the Architect's or Engineer's duty to direct or guarantee the work of the Contractor, but to assist the Owner in obtaining a complete building in accordance with plans, specifications and addenda and to furnish engineering services in accordance with recognized practices.

#### 1.9 PRIOR APPROVALS

- A. The Contractor shall base his proposal on materials as specified herein. Any references to a specific manufacturer or trade name is made to establish a standard of quality and to define a type of product and in no way is intended to indicate a preference for a particular manufacturer. It is the intent of these specifications to allow all manufacturers of equipment, products, etc., judged equal to the specified product to bid on a competitive basis.

#### 1.10 MEASUREMENTS

- A. The Contractor shall verify all measurements and shall be responsible for the correctness of same, before ordering any materials or doing any work. No extra charge or compensation will be allowed for any differences between the actual measurements and those indicated on the drawings.

#### 1.11 LAWS, PERMITS AND FEES

- A. The entire electrical work shall comply with the rules and regulations of the City, Parish, and State, including the State Fire Marshal and State Board of Health, whether so shown on plans or not. The Contractor shall pay fees for permits, inspections, etc., and shall arrange with the inspecting authorities all required inspections.

#### 1.12 SITE INSPECTION

- A. The Contractor shall visit the site and familiarize himself with difficulties attendant to the successful execution of the work before bidding. Failure to visit the site shall not relieve the Contractor of the extent or conditions of the work required of him.

#### 1.13 TEMPORARY FACILITIES

- A. The Contractor shall utilize existing building service for construction power.

### PART 2 - PRODUCTS

#### 2.1 MATERIAL AND EQUIPMENT

- A. All materials, equipment, and accessories installed under this Contract, whether approved or not, shall be new and shall conform to all rules, codes, etc., as recommended or adopted by the National Association(s) governing the manufacture, rating and testing of such materials, equipment, and accessories.
- B. Product Substitutions
  1. If item of equipment or device offered as Substitution differs in dimension or configuration from that indicated in the Contract Documents, provide, as part of the substitution submittal, a drawing that shows that the equipment or devices proposed for Substitution can be installed in the space available without interfering with other trades or with access requirements for operations and maintenance in the completed project. Drawings shall be of appropriate scale but shall not be smaller than a scale of 1/4-inch equals one foot.
  2. Where substitute equipment or devices requires different arrangement or connections from that indicated in the Contract Documents, install the equipment

or devices to operate properly and in accordance with the requirements of the Contract Documents. Make incidental changes necessary in piping, ductwork or wiring which results from the inclusion of the substitute equipment or device without any additional cost to the Owner. Pay all additional costs incurred by other trades in connection with changes required by the inclusion of the substituted equipment or device in the Work.

## 2.2 SHOP DRAWINGS & SUBMITTALS

- A. Shop drawings shall be taken to mean detailed drawings with dimensions, schedules, weights, capacities installation details, and pertinent information that will be needed to describe the material or equipment in detail.
  - 1. Shop drawings shall be prepared using computerized digital software compatible with AutoDesk's AutoCAD
  - 2. Submit hardcopy of Shop Drawings in the quantity as required under Division 01. Hardcopies of Shop Drawings shall have each sheet clearly labeled with a unique sheet identification number.
  - 3. In addition to hardcopies required by Division 01, submit one copy of Shop Drawings in electronic format on Flash Drive. Files contained shall be named to correspond with the sheet names contained in the hardcopy set. Files on shall include both AutoCAD compatible source files and files printed to Portable Document Format (.pdf).
- B. Submittals shall be taken to mean catalog cuts, general descriptive information, catalog numbers, and manufacturer's name.
- C. Review of submittals or shop drawings shall not remove the responsibility for furnishing materials or equipment of proper dimensions, quantity and quality; nor will such review remove the responsibility for error in the shop drawings or submittals.
- D. Assume all costs and liabilities, which may result from the ordering of any material, or equipment prior to the review of the shop drawings or submittals, and no work shall be done until the shop drawings or submittals have been reviewed. In case of correction or rejection, resubmit until such time as they are accepted by the Owner's representative and such procedures will not be cause for delay. After the final review, 6 copies will be supplied if requested.
- E. Shop drawings and submittals will be returned unchecked if the specific items proposed are not clearly marked, or if the general Contractor's approval stamp is omitted.
- F. Shop drawings, unless mark-ups are very trivial, will not be returned, "No Exception Taken". They will be returned for re-submittal as many times as necessary, however, the Contractor shall be back charged for engineering review time beginning with the second resubmittal. Therefore, the Contractor should make every effort to comply with the requirements of this Project on the first submittal in order to avoid project delays.
- G. The Contractor shall submit to the Architect complete descriptive and dimensional data on the following items for review and approval when specified or provided:
  - 1. Fire Alarm System Annunciation Devices
  - 2. Lighting Controls
  - 3. Lighting Fixtures



#### 4. Wiring Devices

### PART 3 - METHODS OF INSTALLATIONS

#### 3.1 CONTRACTOR COORDINATION

- A. The Drawings are diagrammatic in nature. Cooperate with other trades so the interferences of facilities and equipment will be avoided.
- B. Contractor to coordinate with door hardware provider, architect and owner prior to installation of any devices associated with doors to verify door operational requirement, placement of proximity readers, motion sensors, door switches, fire alarm control, magnetic locks, hold open devices, etc..
- C. Space allocations for materials, equipment and devices have been made on the basis of present and known future requirements and the dimensions of items of equipment or devices of a particular manufacturer. Verify that all materials, equipment and devices proposed for use on this Project are within the constraints of the allocated space.
- D. Coordinate arrangement, mounting, and support of electrical equipment:
  - 1. To allow maximum possible headroom unless specific mounting heights that reduce headroom are indicated.
  - 2. To provide for ease of disconnecting the equipment with minimum interference to other installations.
  - 3. To allow right of way for piping installed at required slope. So, connecting raceways, cables, wireways, cable trays, and busways will be clear of obstructions and of the working and access space of other equipment.
- E. Coordinate installation of required supporting devices and set sleeves in cast-in-place concrete, masonry walls, and other structural components as they are constructed.
- F. Where conduit, cable or other items that are provided for under this contract penetrate fire rated walls or floors, the Contractor is to seal around the item to maintain the integrity of the rated system.

#### 3.2 PAINTING

- A. Painting shall be performed as described in the painting specifications. No painting will be required by the Contractor except for touch-up of factory finishes on equipment furnished under this contract.

#### 3.3 INSTALLATION

- A. Equipment must be leveled and set plumb. Use corrosion resistant mounting hardware. For sheet metal enclosures mounted against a wall provide corrosion-resistant spaces to separate the wall by 1/4 inch or by 3 inches of air for freestanding units.
- B. Unused knockouts on panels and boxes shall be covered with approved cover plates manufactured for the purpose.

### 3.4 TESTS AND INSPECTIONS

- A. The Contractor shall assist in making periodic inspections or tests required by the Architect or Engineer. When requested, the Contractor shall provide the assistance of foremen and qualified craftsmen for reasonable duration of each test, etc.
- B. The contract will not be declared to be substantially complete until all of the following conditions are satisfied.
  - 1. the functional operation of the subsystems have been demonstrated and verified and reports have been provided, reviewed and accepted.
  - 2. The “As-Built” drawings have been submitted, reviewed and accepted by the Architect / Owner / Owner’s Construction Representative.

### 3.5 SAFETY PRECAUTIONS DURING CONSTRUCTION

- A. It shall be the Contractor's responsibility to furnish and install proper guards and instruction signs for prevention of accidents and to provide and maintain for the duration of construction any installations needed for safety of life and property.

### 3.6 CONNECTIONS

- A. This Contractor shall be responsible for providing electrical service to all devices of the heating and air conditioning system, and is referred to the mechanical plan for the exact location of the various devices.
- B. Mechanical Controls: Provide 120VAC power connections as required to components of Mechanical Control system. Coordinated quantity of circuits, connection requirements and locations between trades and with provisions of Divisions 21, 22, and 23 sections.
- C. Motors and Motor Connections: Motors for driven equipment are specified in Divisions 21, 22, and 23. Provide connections as follows, unless otherwise indicated:
  - 1. Equipment provided with factory installed disconnecting means: Upon installation of motor and associated equipment, Provide the electrical installation in accordance with approved wiring diagrams and manufacturer’s written instructions.
  - 2. Equipment furnished with factory disconnecting means: Upon installation of motor and associated equipment, Install factory furnished disconnecting means and provide the electrical installation in accordance with approved wiring diagrams and manufacturer’s written instructions.
  - 3. Equipment not furnished with factory installed disconnecting means: Provide disconnect switch required in accordance with NFPA 70 or as indicated on the Drawings. Provide the electrical installation in accordance with approved wiring diagrams and manufacturer’s written instructions.

### 3.7 LOAD BALANCING

- A. Balance load on all phases in each panel to within 10% of respective phase loads.

### 3.8 IDENTIFICATION OF EQUIPMENT

- A. Identification of Equipment:

1. Junction Box, Outlet Box & Wireway/Gutters: Identify conduits, pull boxes, junction boxes, and outlet boxes with the complete circuit number contained there-in.
  - a. Where low voltage relay panels are used for lighting control, identify the low voltage relay panel and number in addition to the branch circuit panel and number.
  - b. Emergency circuit junction boxes shall have a red painted cover. Circuit identification shall be clearly marked on the cover.
  - c. Fire alarm circuits (only) shall be marked with a half red painted junction box and noted "Fire Alarm" on the cover.
2. Pull Boxes, Disconnect Switches, etc.: Label each with a name plate showing identity, voltage and phase and identifying equipment connected to it. The transformer rating shall be shown on the panels or enclosures. Nameplates shall also indicate where panel is fed from.

### 3.9 COMPLETION

- A. The Contractor shall leave all electrical equipment with proper connections, and in proper working order. He shall test the entire electrical system to show that it is properly installed. Contractor shall leave all panels and switches completely fused or complete with circuit breakers.

### 3.10 RECORD DRAWINGS

- A. The Contractor shall furnish one (1) complete set of drawings on which any changes in the work shall be shown. In addition to changes in work contractor shall clearly indicate routing of all feeders both above and below ground. All underground conduit shall be noted on drawings to show "as built" locations. These drawings must be turned over to the Architect prior to final acceptance of the work.

### 3.11 GUARANTEE

- A. The Contractor shall guarantee to keep the entire electrical system as installed by him or his subcontractors in repair and in perfect working order for one (1) year from the date of the final Certification of Final Acceptance, and shall furnish free of cost to the Owner, all material and labor necessary to comply with the above guarantee; said guarantee shall be based upon defective material and workmanship. In any case where equipment has a factory warranty exceeding this one-year limit, the full extent of the warranty shall apply.

### 3.12 CLEANING

- A. When all work has been finally tested, the Contractor shall clean all fixtures, equipment, conduits, ducts, and all exposed work. All cover plates and other finished products shall be thoroughly cleaned.

### 3.13 VANDAL RESISTANT DEVICES

- A. Where vandal resistant screws or bolts are employed on the project, deliver to the Owner 2 suitable tools for use with each type of fastener used, and 25 percent spare fasteners.

- B. Proof of delivery of these items to the Owner shall be included in the Operating and Maintenance Manuals.

### 3.14 INSTRUCTION MANUALS

- A. The Contractor shall provide three (3) operating and maintenance instruction manuals on all systems and equipment installed in the electrical work.
- B. The Contractor shall provide (3) copies of all warranties and guarantees for systems, equipment, devices, and materials.

### 3.15 ADDITIONAL DEVICES

- A. The Contractor shall include in the price for this project the costs to furnish and installed devices/systems with described below. Any device/system not used shall be returned to the owner at the completion of construction. A credit shall be given for the un-used labor and materials at the completion of the project.
- B. The additional devices/systems included in bid pricing are as follows:
  - 1. Fire Alarm: All devices below shall be complete with conduit, wiring any/all associated programming and any applicable submittal documents for State Fire Marshal Review.
    - a. Three (3) speaker/strobe alarm devices
- C. These Specifications and the electrical Drawings size equipment, wire, conduit, etc. based on the horsepower of motors and/or wattages of equipment as shown on the plans or specified herein. The Contractor shall install electrical raceways, conductors, fuses, safety switches, breakers, contactors, starters or any other electrical equipment with the capacities to suit the horsepower and/or wattages of the equipment actually furnished and installed. The Contractor shall not furnish or install any electrical raceways, conductors, safety switches, contactors or motor starters of sizes smaller than those shown on the Drawings or specified herein. The Contractor shall coordinate with the various sections of the Specifications and/or Drawings and with the various Sub-Contractors to provide the properly sized equipment without additional cost to the Owner.

END OF SECTION 26 01 00

## SECTION 26 05 05 - ELECTRICAL DEMOLITION

### PART 1 - GENERAL

#### 1.1 SUMMARY

- A. Section Includes:
  - 1. Provide all labor, material and equipment to perform all electrical demolition as specified and as shown on the Drawings.
  - 2. All equipment selected for demolition shall have power and communication cables de-energized and disconnected. All disconnected cables shall be removed.
  - 3. All conduit shall be disconnected and removed from demolished equipment.
  - 4. Contractor is responsible for making equipment scheduled for demolition safe for removal.
  
- B. Related Documents:
  - 1. Drawings and general provisions of the Contract, including General and Supplementary Conditions and Owner's General Requirements, apply to this Section.

#### PART 2 - PRODUCTS Not Used

### PART 3 - EXECUTION

#### 3.1 EXAMINATION

- A. Verify that field measurements and circuitry arrangements are as shown on the Drawings.
- B. Verify that abandoned wiring and equipment serve only abandoned facilities.
- C. Demolition work indicated on drawings are based on casual field observation and existing record documents. Report discrepancies to Engineer before disturbing any existing installation.
- D. The Contractor accepts existing conditions by starting demolition work.
- E. Contractor shall familiarize himself with the existing electrical site systems and with the work of all other trades and include all work necessary to comply with the intent of this section.
- F. It shall be understood that field conditions may be encountered during the execution of this contract which will require extension or relocation of existing systems or equipment which are not specifically shown on the drawings, but, which are required to meet the stated intent that the existing electrical system continue to function unaffected by the demolition and associated new construction. Contractor shall include such work as would normally be expected to accomplish the work.

- G. The bidder is required to visit the project site prior to submitting bid to verify the exact configuration of the electrical items being removed, relocated, or modified. No claims for extra work shall be accepted after awarding of bids for discrepancies between verifiable field conditions and the items shown on drawings if these items are readily verifiable.
- H. Should this contractor encounter field conditions which, in their opinion, were not verifiable by visual inspection of the site prior to submitting bids, they shall notify the Engineer immediately, in writing, and request a decision as to the scope of work. The Engineer shall provide the necessary interpretations and instructions in a reasonable time.

### 3.2 PREPARATION

- A. Coordinate electrical power outages with appropriate utility company and Owner. All outages must be scheduled with owner a minimum of 2-weeks in advance. Outages shall be scheduled as to minimize disruption and outage duration.
- B. Investigate the existing conditions of electrical system in walls, floors and ceilings scheduled for removal.
- C. Disconnect and deliver to the Owner those items requested to remain the Owner's property.
- D. Provide temporary wiring and connections to maintain existing systems in service where needed. When work must be performed on energized equipment or circuits, use personnel experienced in such operations.

### 3.3 DEMOLITION OF ELECTRICAL FACILITIES

- A. Demolish electrical work under provisions of this section. All electrical items indicated to be removed shall remain Owner's property unless stated otherwise. All removed electrical items that the Owner does not wish to keep shall become Contractor's property and removed from the site.
- B. For demolition in buildings that are to be removed as part of demolition work:
  - 1. Remove abandoned wiring to source of supply.
  - 2. Disconnect electrical devices and equipment serving equipment that has been (or will be) removed.
  - 3. Fill with compacted soil any trench, hole or cavity created by the relocation or removal of any existing conduit, and pole concrete base.
- C. For demolition in buildings that are to remain in service after completion of demolition work:
  - 1. Remove exposed abandoned raceways.
  - 2. Repair adjacent construction and finishes damaged during demolition and extension work.
  - 3. Maintain access to existing electrical installations which remain active. Modify installation or provide access panel as appropriate.
  - 4. Where new construction conflicts with existing electrical work which is to remain, relocate the electrical work involved.
  - 5. Where existing circuits are interrupted by demolition or new work, extend and

reconnect those systems. Where those systems must remain in service during the execution of this contract, provide temporary connections until final connections are complete.

6. Any parts of existing construction which are to remain and which are damaged during demolition and preparatory work or new construction work on the project shall be patched to match existing adjacent surfaces. Patching and finishing of such areas shall conform with all applicable requirements of other technical sections of these specifications, and shall match existing work in material, type, finish, etc.
7. Equipment, circuits and utilities that remain, but that are served by feeders or circuits being removed or altered shall be reconnected in accordance with the methods required by this specification and the NEC, without extra cost to the Owner.
8. All materials and equipment noted to be reused or relocated shall be cleaned, retested, repaired if necessary, modified if required, prepared for reuse, and be stored and protected from the outdoor environment on the site until it is time for re-installation.
9. Fill with compacted soil any trench, hole or cavity created by the relocation or removal of any existing conduit, and pole concrete base.
10. Remove all abandoned data cabling located above ceilings that are exposed during demolition.
11. Where demo of electrical equipment is shown this shall include demolition of any unused supports, housekeeping pads, and associated conduit/conductor.
12. Disconnect and remove all abandoned equipment including but not limited to panelboards, and disconnect switches.
13. Where labeling is required by project specifications contractor shall trace and label all circuits to remain that are affected by construction or demolition.

### 3.4 DISPOSAL OF DEMOLISHED MATERIALS

- A. Except for items or materials indicated to be recycled, reused, salvaged, reinstalled, or otherwise indicated to remain Owner's property, remove demolished materials from Project site and legally dispose of them in an EPA-approved landfill.
  1. Do not allow demolished materials to accumulate on-site.
  2. Remove and transport debris in a manner that will prevent spillage on adjacent surfaces and areas.
  3. Transport demolished materials off Owner's property and legally dispose of them.

### 3.5 CLEANING AND REPAIR (FOR FACILITIES TO REMAIN IN SERVICE)

- A. General
  1. Clean and repair existing materials and equipment which remain or are to be reused.

END OF SECTION 26 05 05

## SECTION 26 05 50 - BASIC ELECTRICAL MATERIALS AND METHODS

### PART 1 - GENERAL

#### 1.1 GENERAL REQUIREMENTS

- A. All material furnished shall be new and shall conform to all rules and codes as recommended or adopted by the National Association governing the manufacture, rating and testing of the material. All electrical equipment shall be UL listed for the intended use.

### PART 2 - PRODUCTS

#### 2.1 RACEWAYS AND FITTINGS

- A. Raceways permitted on this project shall be galvanized rigid conduit; electrical metallic tubing (EMT); flexible metallic tubing; liquid-tight flexible metal conduit; and rigid polyvinyl chloride (PVC) conduit. All conduits shall be new and shall bear the inspection label of the Underwriter's Laboratories, Inc.
- B. Metallic conduit shall be metalized, or hot-dipped galvanized. Non-metallic conduit shall be schedule 40 PVC.
- C. Fittings for conduit shall be an approved type specially designed and manufactured for their purpose. EMT fittings shall be water tight, compression type. Rigid metal conduit fittings, bushings, and other components shall be galvanized steel. All fittings for rigid steel or aluminum conduit shall be threaded and coupled unless specifically approved otherwise by the Engineer.
- D. Where conduit connects to an outlet box, it shall have an insulated throat type connector.

#### 2.2 EXPOSED CONDUIT

- A. Exposed conduit shall be firmly supported on galvanized hangers; on brackets, hangers, or pipe straps; or by beam clamps. Conduit installed exposed shall be neatly aligned and run at right angles to the building walls or walls of the rooms in which installed. All exposed conduit shall be located to avoid all conflicts with architectural or mechanical components.

#### 2.3 FLEXIBLE CONDUIT

- A. Liquid-tight flexible metal conduit shall have a spiral wound, flexible, galvanized steel core and a tough extruded synthetic moisture-tight outer covering. All flexible conduits shall be UL listed.

#### 2.4 CONDUIT

- A. Each piece of conduit shall be straight, free from blisters and other debris, cut square



and taper reamed, and furnished with coupling in 10 foot length threaded each end.  
exterior locations.

- B. Boxes for lighting fixtures shall be 4 inches octagon, not less than 1-1/2 inches deep, with fixtures stud fastened through from back box. Where boxes are installed in a concrete slab, boxes designed for this application shall be used.
- C. Outlet boxes for switches in concealed work shall be standard switch boxes of required number of gangs. Outlet boxes for receptacles, telephone, and communication use in concealed work shall be 4 inch square, not less than 1-1/2 inches deep. Outlet boxes for switches and receptacles installed in exposed conduit system shall be cast type FS or FD, number of gang as required. Outlet boxes for telephone and communication use in exposed systems to be cast, 4 inches square, not less than 1-1/2 inches deep.
- D. Boxes shall not to be installed back to back in walls. Offset with connecting conduit as specified. Do not use long, extended boxes that would effectively couple light and sound between adjoining spaces.

## 2.5 WIRE (600 VOLT AND BELOW)

- A. All conductors used in the work shall be of soft drawn annealed copper having a conductivity of not less than 98% of that of pure copper. Conductors shall be standard code gauge in size, insulated and shall have insulation rated for use at 600 volts.
- B. Unless noted otherwise or specified, insulation shall be type THW, THWN, or THHN for sizes up to and including No. 2 AWG. Insulation for wire sizes larger than No. 2 AWG shall be type THW, XHHW, or THHN. Lighting fixture wire shall be heat resistant type TF (150°C) with 300-volt insulation minimum. Wires shall be of the single conductor type. Sizes No.14 AWG and larger shall be stranded. No wire shall be single strand solid copper.
- C. Throughout the system, all conductors shall be identified as to the phase and voltage of the system by color-coding in accordance with NEC 210.5. Color-coding shall be continuous the full length of the wire with surface printing at regular intervals on all conductors and for neutral conductors.
- D. Color coding shall be as follows:

3phase, 480V System	3phase, 208V System
Phase 1-Brown	Phase 1-Black
Phase 2-Orange	Phase 2-Red
Phase 3-Yellow	Phase 3-Blue
Neutral-Gray	Neutral-White
Ground-Green	Ground-Green

## 2.6 WEATHERPROOF RECEPTACLES

- A. Weatherproof receptacles shall be GFCI duplex receptacles as specified under WIRING DEVICES, mounted in a cast iron type FD conduit box and fitted with gasketed metal cover with spring. Weatherproof receptacles shall be flush mounted in exterior walls.

## 2.7 WIRING DEVICES

- A. Wiring devices shall be as listed. The color of device shall match color of outlet cover plate. It shall be the responsibility of the Contractor to provide plugs, receptacles and fittings required for any equipment furnished or installed or connected under the contract. Color as selected by the Architect.

	Leviton	P & S	Hubbell
Toggle Switches: 20A 120/277V			
Single pole	1221-I	20AC1-I	1221-I
Three-way	1223-I	20AC3-I	1223-I
Duplex Receptacle: 20A, 125V, NEMA 5-20R	5362-I	5362-I	5363-I
Ground Fault Circuit Interrupter: 20A, 125V, Feed Through, NEMA 5-20R	6899-I	2091-S	GF-5362-I

- B. Quad receptacles shall be 20 amp, 125 volt rated, NEMA 5-20R, with two (2) duplex receptacles or single four-plex device.

## 2.8 OUTLET COVER PLATES

- A. Unless otherwise specified, all outlets shall be fitted with cover plates. Cover plates shall be standard size, uniform in design and finish for switches, receptacles and other outlets requiring cover plates. Plates shall be one piece of the required number of gangs. All cover plates shall be lexan unbreakable type. Architect shall select coverplate color.

## 2.9 SPECIAL PURPOSE RECEPTACLE

- A. Provide receptacles for special purpose devices as indicated on the plans. Refer to equipment specification for proper receptacle to be supplied. Provide stainless steel cover plate.

## 2.10 FIRESTOPPING PRODUCTS

- A. The Contractor shall provide and install at all fire-rated wall through-penetrations, a non-hardening, conformable firestop system. The system shall consist of a water insoluble putty and suitable damming materials (where required). The non-hardening putty shall be a two-staged intumescent and capable of expanding up to 8 times its original volume. This putty shall contain no asbestos, no fiberglass, no solvents nor corrosive mineral salts of any kind. It shall remain soft during its installed life and shall be capable of being removed and reinstalled to facilitate the addition of cables or pipes. The putty shall exhibit aggressive adhesion to all common building materials and penetrants and shall allow reasonable movement of penetrants without being displaced. The firestop system shall be tested to the time/temperature requirements of ASTM E119 and shall be tested to UL 1479 (ASTM E814) and Classified for up to 3 hours.

## PART 3 - EXECUTION

### 3.1 WIRING - GENERAL

- A. Unless otherwise specified, all wiring shall be installed in conduit. No wire shall be smaller than No. 12 unless noted otherwise. Wiring for low voltage control may be #14 AWG. Wire for each branch circuit shall be of single size and type from the branch circuit protective device the last outlet of the circuit. BX wiring shall not be allowed.
- B. Feeders, motor circuit conductors and main service entrance conductors shall run their entire length without joints or splices. Wiring for branch circuits shall run the entire length without splices, with splices and joints made only at outlets or in accessible junction boxes only when absolutely necessary and approved by the Engineer. Joints and splices in branch circuit wiring shall be made with compression type solderless connectors.
- C. Connectors of the non-metallic screw on type are not acceptable. Terminations or splices for conductors No. 6 AWG and larger shall utilize bolted connecting lugs. All splices and terminations shall be insulated in an approved manner by an integral or separate cover or by taping to provide insulating value equal to that of the conductors being joined.
- D. Type THW or THWN conductors may be connected directly to recessed fixtures only when the fixtures are equipped with outlet boxes listed by Underwriter's Laboratories, Inc. for use with wire having insulation rated for maximum operating temperatures of 75°C (167°F); otherwise, for fixtures not rated for 75°C directly connection, use 125°C insulated conductors from the fixture to an outlet box placed at least one (1) foot, but not more than four (4) feet from the fixture.
- E. Branch circuit home run numbers shown on the drawings shall be used as a guide for connection of circuit wiring to similarly number protective devices in branch circuit panelboards. Requests for changes in the plans shall be directed to the Architect. No changes shall be made without approval from the Architect.
- F. Each circuit shall be furnished with its own neutral conductor. There shall be no sharing of neutral conductors.
- G. In instances where a junction box, wireway, etc. contains three (3) or more branch circuits, the feeders shall be labeled within the junction box, wireway, etc. with circuit location, including panel name and breaker number. Labeling shall be neatly typed and affixed to each feeder. Labeling shall meet all applicable Code requirements.

### 3.2 ELECTRICAL SERVICE GROUNDING

- A. Main electrical service equipment, conduit work, motors, panelboards and all other electrical equipment shall be effectively and permanently grounded. Grounding connections and conductor sizes shall be in accordance with requirements of the National Electrical Code, Article 250 and local or State ordinances.
- B. All conduit entering panelboards shall be grounded to the panelboard by means of a grounding type locknut installed on the inside of the panelboard. Where the continuity of

the metallic conduit system is interrupted by a run of non-metallic conduit, a separate grounding conductor, sized in accordance with NEC Table 250.122 shall be run in the conduit with the insulated conductors. A separate grounding conductor, as described above or as called for on the plans, shall be run in the conduit with the circuit conductors for all circuits serving multi-outlet assemblies.

- C. Conduit runs shall be increased in size where necessary to accommodate the grounding conductor in addition to circuit conductors. The grounding screw on all grounding type receptacles shall be securely grounded to the outlet box using a No. 12 green insulated conductor attached to the outlet box with lug screw.
- D. All switch legs shall include a green ground conductor connected to the circuit ground conductor and terminated in the switch outlet box.

### 3.3 CONDUIT - MATERIALS AND METHODS

- A. Conduit shall be installed as per NEC and NEMA regulations and the manufacturer's recommendations. Conduit shall be as follows:
  - B. Rigid Steel Conduit shall be used for all conduits exposed to the weather, and underground conduit except where non-metallic conduit is specified or approved. Underground and under slab runs are to be watertight. All horizontal runs of underground conduit shall utilize rigid steel elbows on vertical risers. Conduits used for receptacles and run under the building slab, shall be hot dipped galvanized rigid steel and shall be 3/4" minimum size.
  - C. All conduits routed underground shall not be placed in building slab. Conduits larger than 1" routed under building slab shall be routed below the vapor barrier. Minimum conduit size allowed to be routed underground shall be 3/4". Conduits routed under building slab may be PVC. All conduits rising vertically out of slab or out of ground shall be type RMC to 48" above finished floor.
  - D. Electrical Metallic Tubing shall be used for all other feeders, branch circuit and communications and control wiring where rigid steel or non-metallic conduit is not specified.
  - E. Non-metallic conduit, minimum schedule 40 PVC, shall be permitted to be installed underground. Non-metallic conduit shall not be used in any environmental air plenum. If PVC conduit is run, a full sized grounding conductor shall be pulled with the circuit conductors. PVC conduit shall not be run exposed. Where PVC conduit is run underground, it shall be encased in concrete or run minimum 24" below grade, or at the depth below grade shown on the drawings.
  - F. Flexible metallic tubing and EMT shall only be permitted in spaces above finished ceilings and within enclosed walls within the interior of buildings. Flexible metallic tubing shall only be permitted for the final four (4) feet of conduit runs to fixtures located above finished ceilings. No flexible metallic tubing or EMT will be permitted exposed. Also, EMT may not be installed in or below concrete slabs.
  - G. Flexible metal conduit or liquid-tight flexible metal conduit shall be used for the final connection of runs to motors. Flexible conduit shall be at least twelve (12) inches, but

not more than 48 inches long. Where used, an external grounding conductor shall be run with conduit unless conductor is made as a part of the conduit.

- H. Conduits installed underground and used for communications system wiring shall be reviewed with the communications contractor prior to installation. Conduits below the vapor barrier may require moisture proof wiring to comply with the structured connectivity solution. Conduits may need to be installed above the vapor barrier to maintain connectivity solution compliance.

### 3.4 CONDUIT - GENERAL

- A. Fittings for rigid steel conduits shall be hot-dipped galvanized steel and shall be of a type especially designed and manufactured for their purpose. Fittings for EMT shall be die cast zinc type. Rigid conduit joints for single conduit runs shall be made with threaded fittings made tight with at least five threads fully engaged. Fittings for rigid non-metallic conduit shall be solvent welded.
- B. Where they enter boxes or cabinets that do not have threaded hubs, conduits shall be secured in place with galvanized locknuts inside and outside the cabinet and shall have bushings inside. Conduits larger than 1-1/4 inch shall have galvanized locknuts and galvanized bushings.
- C. All conduits shall be installed concealed or as indicated or scheduled on the drawings and shall be of sufficient size to accommodate the required number of insulated conductors including equipment grounding conductor where such grounding conductor is required or specified.
- D. Conduit runs shall be straight; elbows and bends shall be uniform, symmetrical and free from dents or flattening. Exposed conduit shall be firmly supported on galvanized hangers; on brackets, hangers, or pipe straps; or by beam clamps. Conduit installed exposed shall be neatly aligned and run at right angles to the building walls or walls of the rooms in which they are installed. All exposed conduit shall be located to avoid all conflicts with architectural or mechanical components.
- E. Pull boxes shall be installed as required to permit proper installation of conductors and expansion fittings installed where conduit runs cross building expansion joints.
- F. Conduit shall be run no closer than six (6) inches to covering of hot water or steam piping except where crossings are unavoidable. Conduit shall be kept at least one (1) inch from crossing steam and hot water piping.
- G. Conduit shall be held securely in place by hangers and fasteners of appropriate design and dimensions for the particular application. Support shall be such that no strain will be transmitted to outlet box and pull box supports. Wire shall not be used, with or without spring steel fasteners, clips or clamps, for the support of any conduit. Conduit shall not be supported by or attached to duct work unless specifically allowed otherwise.
- H. Hangers and other fasteners shall be supported on solid masonry with inserts or expansion sleeves and bolts, on wood with wood screws, hollow masonry with toggle bolts, on steel with machine screws or welded threaded studs. Fastenings shall be proof tested by the Contractor for secure mounting.

- I. All conduits shall be cut square and reamed at the ends. The conduit system shall be complete and cleaned before any conductors are installed. Open ends of all conduits shall be capped until conductors are installed. A non-metallic fish wire shall be installed in all empty conduits. Empty conduit shall remain capped.
- J. Contractor shall refer to National Electrical Code Appendix C, Conduit and Tubing Fill Tables for Conductors and Fixture Wire of the Same Size. Contractor shall refer to the appropriate table for the conduit and wire condition and shall install wiring in accordance with code requirements.
- K. Contractor shall provide pull box for every 270 degrees of bend. This shall apply to underground and above ground conduit. Where the run is under slab, contractor shall provide an appropriate pull box for the traffic rating.

### 3.5 FLEXIBLE CONDUIT

- A. Flexible metal conduit may be used for short final connections to equipment where permitted by governing codes. Flexible metal conduit shall be sized and supported in accordance with Article 350 of the NEC or more stringent local codes. A separate equipment-grounding conductor sized in accordance with NEC Table 250.122 shall be installed in flexible conduit unless exceptions are allowed by governing codes and if the fittings used are UL listed for the purpose.
- B. Liquid-tight flexible metal conduit shall be used where flexible conduit is permitted and desired and conditions of installation, operation, or maintenance require protection from liquids, vapors, or solids and in other hazardous locations where specifically approved. Flexible conduit for all exterior motor connections shall be liquid-tight. Liquid-tight flexible conduit shall be used with terminal fittings approved for the purpose.

### 3.6 FIRE-RATED WALL AND FLOOR THROUGH-PENETRATIONS

- A. All fire-rated walls or floors penetrated by this Contractor shall be properly sealed with fire stopping materials. All floor through-penetrations shall be fire stopped with a light-weight mortar material. Wall through-penetrations shall be fire stopped with a non-hardening putty material. Contractor shall see that all penetrations are fire stopped and seals are inspected.

### 3.7 SUPPORTS AND FITTINGS

- A. The Contractor shall furnish and install all supports for equipment under this contract. Supports shall be spaced at intervals of eight (8) feet maximum for rigid conduit and five (5) feet maximum for EMT and as necessary to obtain rigid support. Perforated strap supports will not be permitted.
- B. All conduits shall be firmly secured with pipe clamps, conduit straps, or suspension hangers as appropriate. Fasten to steel with screws in tapped holes, to wood with wood screws, and to masonry with expansion anchors. Expansion anchors shall have a minimum pull out load of 1,200 pounds and an ultimate shear load of 1,950 pounds.
- C. All conduit, fixtures, and accessories shall be rigidly supported to form a firm, well-braced installation.

- D. Joints shall be made tight with standard galvanized or sheradized couplings; corners turned with fittings, elbows, or long radius bends.
- E. Low voltage wiring installed above accessible ceilings shall be supported on J-hooks. J-hooks installed for communications system wiring shall not be used for other low voltage system wiring (fire alarm, security, EMS controls, etc.).

### 3.8 WEATHERPROOF EQUIPMENT

- A. All disconnect switches, starters, and other electrical equipment located on the exterior of the building or exposed to the outside shall be enclosed in a rain-tight enclosure.
- B. All lighting fixtures or other devices located on an exterior wall of the building shall be mounted on a flush-mounted, cast outlet box.

### 3.9 MOUNTING HEIGHTS

- A. Unless otherwise noted on the drawings or required by the Architect, the following mounting heights shall apply:

Toggle Switches	4'-0"
Receptacles	1'-6"
Panelboards	6'-0" to top
Telephone Outlets	1'-6" (48" for wall phone)
Safety Switches	5'-0" to top
Motor Control Equipment	5'-0" to top
Wiring Devices above counters	0'-6" above counter top
Fire Alarm Manual Stations	4'-0"
Fire Alarm Annunciation Devices	80" or 6" below ceiling (whichever is lower)

- B. Upon permission of the Architect, mounting heights may be adjusted to simplify cutting of masonry units or to facilitate furniture and cabinet arrangements. Dimensions above refer to the centerline of the device unless noted otherwise.
- C. Nurse call device installation locations shall adhere to all applicable codes.

END OF SECTION 26 05 50

## SECTION 26 50 00 - LIGHTING

### PART 1 - GENERAL

#### 1.1 LIGHTING SCHEDULE

- A. The Contractor shall install lighting fixtures and accessories as shown on the drawings and/or described herein. The Contractor shall also install lamps for all fixtures.

### PART 2 - PRODUCTS

#### 2.1 LED LIGHTING

- A. Lighting fixtures with LED light sources shall meet the following fixture and light source requirements:
  1. LED Color Temperature: Per Drawings
  2. Color Rendering Index: 80 CRI min
  3. Line Voltage – Universal Voltage 120-277 volts
  4. Governmental Standards – LM79 and LM80 Compliant
  5. Expected Lamp Life – LED Life Rating ( $L_{70} B_{10}$ ) to be 60,000 hours to 100,000 hours; Defined as time of operation (in hours) to 30% lumen depreciation (i.e. 70% lumen maintenance), derived from Luminaire in-situ temperature measurement testing (i.e. LED chip package temperature ( $T_s$ ) measurement obtained with the LED chip package operating in given luminaire and in a given stabilized ambient environment) under UL1598 environments and directly correlated to LED package manufacturers IESNA LM-80-08 data. Predicted ( $L_{70} B_{10}$ ) Limits (@ 25°C luminaire ambient operating environment): Greater than 60,000 hours @ 350mA Drive Current
  6. Driver – Components must be fully encased in potting material for moisture resistance, and must comply with IEC and FCC standards
  7. Surge Protection – Surge protection must be provided including separate surge protection built into electronic driver
  8. Mechanical – Luminaire LED system components to be low copper aluminum, with high performance heat sink(s) designed specifically for LED luminaires. No active cooling features (Fans, etc.). Luminaire configuration must allow for modular upgradability and/or field repair of all electrical components (i.e. LED modules, Driver(s), etc.). Drivers and vertical light bars must be all mounted to a twist-lock tool-less assembly for ease of installation and trouble-shooting.

#### 2.2 LIGHTING ACCESSORIES

- A. All lighting shall be equipped with the appropriate housing for the ceiling type shown on the architectural reflected ceiling plan.
  1. GYP Ceilings –
    - a. 1'X4' 2'X2' & 2'X4' Troffers: Provide flange kit or surface mount kit. If not explicitly indicated on plan contractor shall price based on the more costly product and submit an RFI to Engineer prior to purchase.
    - b. Downlights: Provide recessed housing and appropriate flange kit.
    - c. Strip lighting: Provide surface mount kit. In areas with ceiling heights greater than 10' contractor shall provide chain suspension hardware.



- d. Architectural linear fixtures: Where indicated as recessed contractor shall provide flange kit or mud-in kit as required. If not explicitly indicated on plan contractor shall price based on the more costly product and submit an RFI to Engineer prior to purchase.
  2. Grid Ceilings – Provide appropriate mounting hardware to recess fixtures into grid.
- B. Fire ratings: Lighting in fire rated ceiling shall be equipped with fire padding, caulking, and/or housings as required to maintain fire ratings. Contractor shall refer to architectural plans for all fire ratings prior to bid.
- C. Emergency battery backup and inverters:
1. Where remote battery backup is utilized contractor shall coordinate all remote test switch locations with owner/architect prior to rough in. They shall not be located in ceiling adjacent to fixture.
  2. Where integral battery backup is utilized the fixture shall include self-diagnostics. This shall not be required if specified fixture does not include a self-diagnostic option.
  3. Where an inverter is utilized contractor shall provide UL924 transfer devices in the quantity required to accomplish control as shown on plans. Where inverter fixture utilized line voltage dimming contractor shall notify engineer immediately prior to bid.

## 2.3 FIXTURES

- A. Fixtures as described in the Fixture Schedule on the drawings shall be furnished by the Contractor and shall be properly installed.
- B. Where fixtures are specified with emergency remote test switches contractor shall coordinate location of remote test switch with Owner/Architect prior to installation.

## PART 3 - EXECUTION

### 3.1 INSTALLATION

- A. Unless otherwise specified, lighting fixtures shall be permanently installed and connected to the wiring system.
- B. The Contractor shall support each fixture, independently from the building structure. Ceiling framing members shall not be used to support fixtures except in specified areas where ceiling supports for this purpose have been specified elsewhere in these specifications. Each fixture shall have at least two fixture supports.
- C. Flexible conduit used for fixture whips shall be at least twelve (12) inches, but not more than 48 inches long.

### 3.2 CEILING COMPATIBILITY

- A. Catalog numbers shown on the drawings or descriptions of lighting fixtures contained herein may indicate fixture compatibility with certain types of ceiling construction. Contractor shall determine exact type of ceiling actually to be furnished in each area and

shall obtain fixtures to suit, deviation from specified catalogue numbers or descriptions only where necessary and only to the extent necessary to insure fixture/ceiling compatibility.

### 3.3 LIGHT LEAKS

- A. The Contractor shall, at the end of this project, adjust all recessed lighting fixtures so that there will be no light leaks between the fixture trim and the ceiling. Contractor shall also adjust recessed fluorescent fixtures to eliminate any light leaks between fixture trim and ceiling grid member.

### 3.4 LAMPS

- A. The Contractor shall install lamps in all fixtures and shall obtain replacement lamps should any not properly operate or become damaged during construction.

### 3.5 EXIT FIXTURES

- A. Exit fixtures shall be installed according to Life Safety Code requirements, with face(s) plainly visible and directional arrows indicating the proper direction of egress.

END OF SECTION 26 50 00

# RESTROOM RENOVATIONS

Southern University Laboratory School

AUGUST 31, 2023

129 SWAN AVE,  
BATON ROUGE, LA 70813

## CONSTRUCTION DOCUMENTS

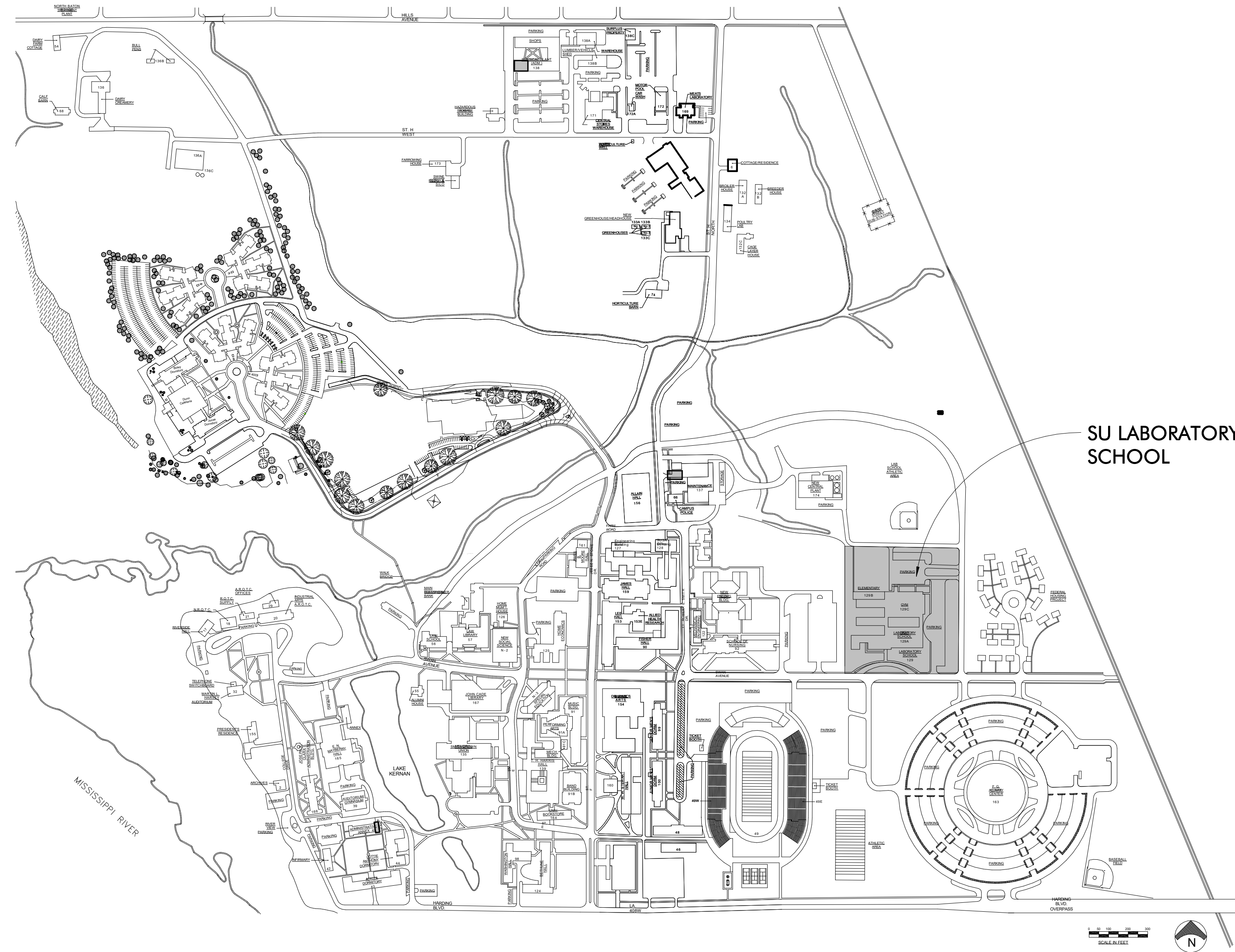

### INDEX OF DRAWINGS

Sheet Number	Sheet Name
<b>GENERAL</b>	
....	CONSTRUCTION DOCUMENTS
11.00	ADA INFO
<b>ENVIRONMENTAL</b>	
EVI.01	ENVIRONMENTAL DEMOLITION FLOOR PLAN
EVI.02	ENVIRONMENTAL DEMOLITION FLOOR PLAN
EVI.03	DETAILS AND GENERAL NOTES
<b>DEMO</b>	
D2.01	1ST FLOOR - DEMO FLOOR PLAN
D2.02	2ND FLOOR - DEMO FLOOR PLAN
D5.01	1ST FLOOR - DEMO RCP
D5.02	2ND FLOOR - DEMO RCP
<b>ARCHITECTURE</b>	
A1.01	SITE PLAN - AERIAL VIEW
A2.01	1ST FLOOR NEW CONSTRUCTION
A2.02	2ND FLOOR NEW CONSTRUCTION
A5.01	1ST FLOOR RCP
A5.02	2ND FLOOR RCP
A9.00	FINISHES
A9.01	KINDERGARTEN
A9.02	EXTERIOR BATHROOM PLANS
A9.03	EXTERIOR BATHROOM ELEVATIONS
A9.04	ART CLASSROOM
A9.05	STAFF PLANS
A9.06	STAFF ELEVATIONS
A9.07	BOYS
A9.08	GIRLS
A9.09	GYM GIRLS
A9.10	GYM BOYS
A9.11	LOCKER ROOM PLANS
A9.12	LOCKER ROOM ELEVATIONS
A9.13	LOCKER ROOM PERSPECTIVES
A9.14	2ND FLOOR BOYS
A9.15	2ND FLOOR GIRLS
A9.16	ADA 1 - RESTROOM
A9.17	ADA 2 - RESTROOM
<b>MECHANICAL &amp; PLUMBING</b>	
MP0.00	MECHANICAL COVER SHEET
MP2.01	1ST FLOOR - MECH & PLUMBING OVERALL FLOOR PLAN
MP2.02	2ND FLOOR - MECH. & PLUMBING OVERALL FLOOR PLAN
<b>MECHANICAL</b>	
M9.01	ENLARGED MECHANICAL PLANS
M9.02	ENLARGED MECHANICAL PLANS
M9.03	ENLARGED MECHANICAL PLANS
M9.20	MECHANICAL SCHEDULES
M9.30	MECHANICAL DETAILS
<b>PLUMBING</b>	
P9.01	ENLARGED PLUMBING PLANS
P9.02	ENLARGED PLUMBING PLANS
P9.03	ENLARGED PLUMBING PLANS
P9.20	PLUMBING SCHEDULES & DETAILS
<b>ELECTRICAL</b>	
E0.00	ELECTRICAL COVER SHEET
E1.00	OVERALL FIRST FLOOR DEMOLITION PLAN
E2.00	OVERALL 1ST FLOOR NEW CONSTRUCTION PLAN
E3.00	OVERALL 2ND FLOOR DEMOLITION PLAN
E4.00	OVERALL 2ND FLOOR NEW CONSTRUCTION PLAN
E5.00	ENLARGED ELECTRICAL
E6.00	ENLARGED ELECTRICAL PLANS
E7.00	ENLARGED ELECTRICAL PLANS
E8.00	ENLARGED ELECTRICAL PLANS

**MEP ENGINEER**  
ADG BATON ROUGE, LLC  
3071 TEDDY DRIVE  
BATON ROUGE, LA 70809  
225.293.9474

**ENVIRONMENTAL ENGINEER**  
RAYNER CONSULTING GROUP, LLC  
7353 HIGHLAND RD, SUITE B-3B  
BATON ROUGE, LA 70808  
225.916.2824

**ARCHITECT**  
DOMAIN ARCHITECTURE  
8316 KELWOOD AVE.  
BATON ROUGE, LA 70806  
225.216.3770



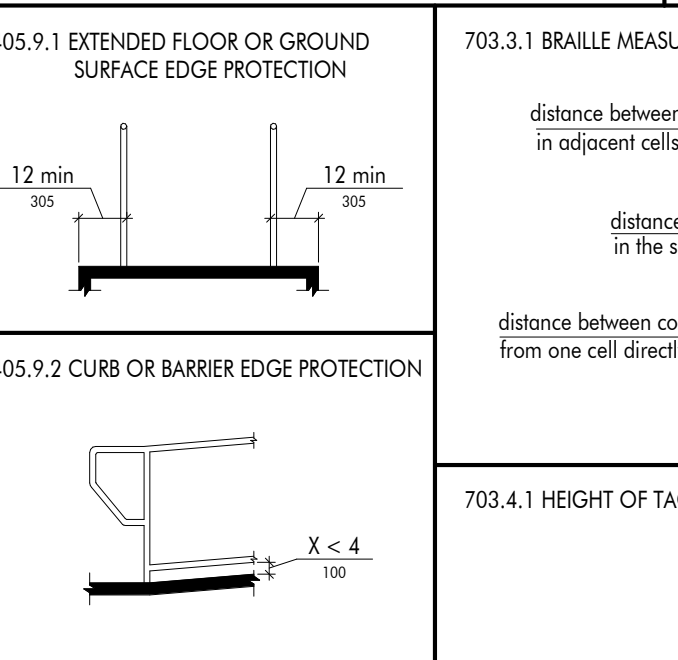
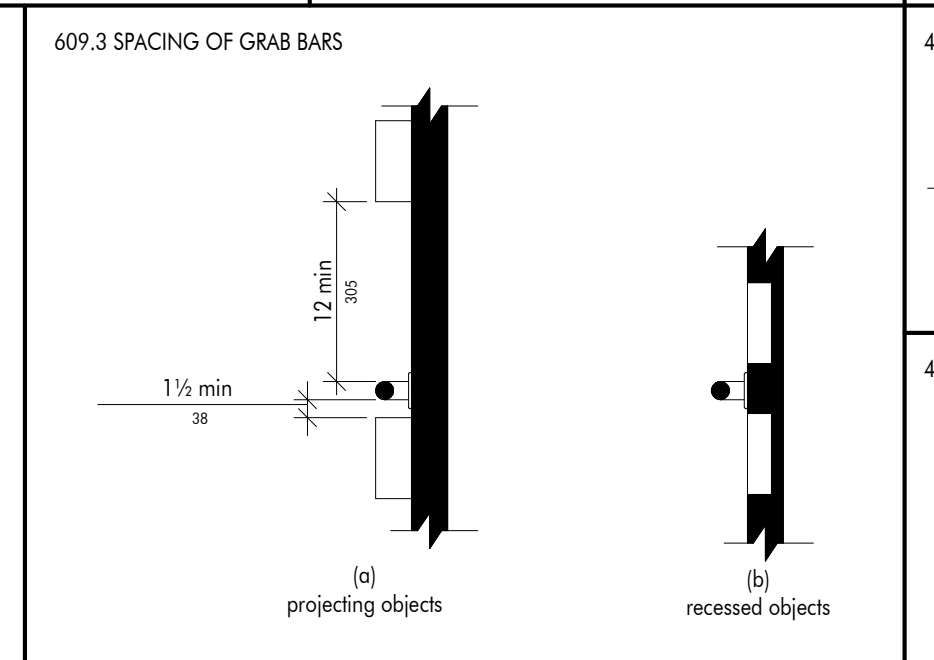
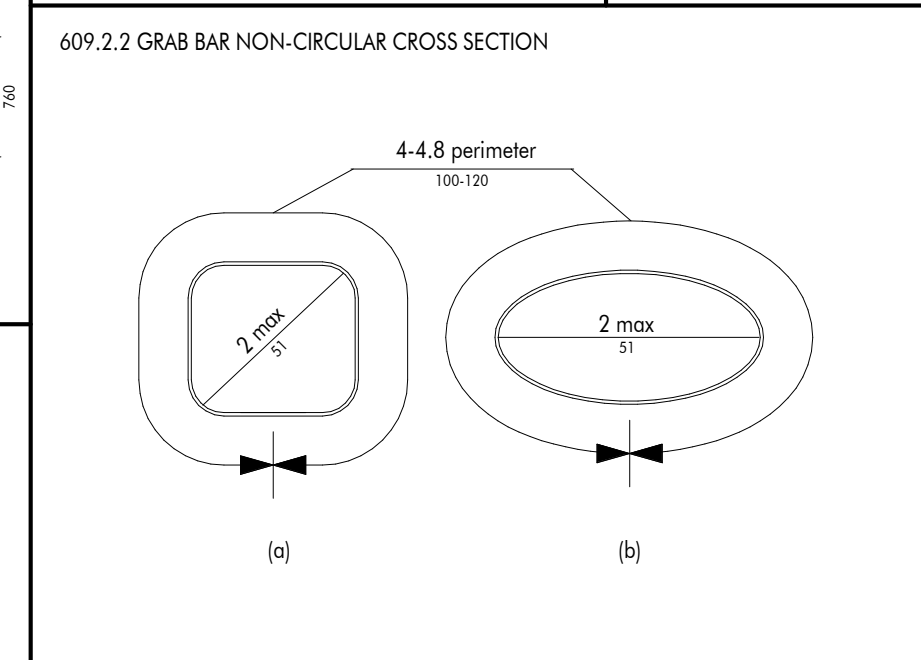
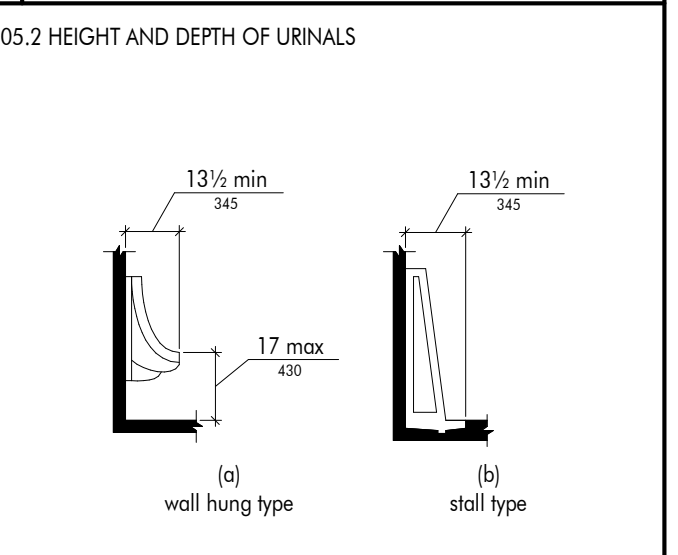
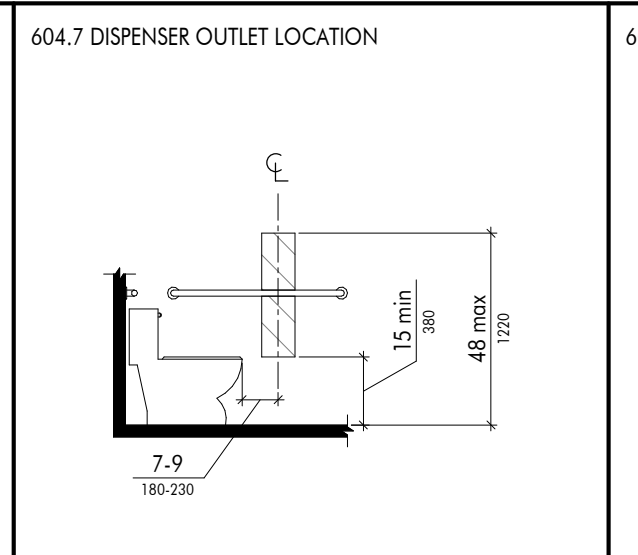
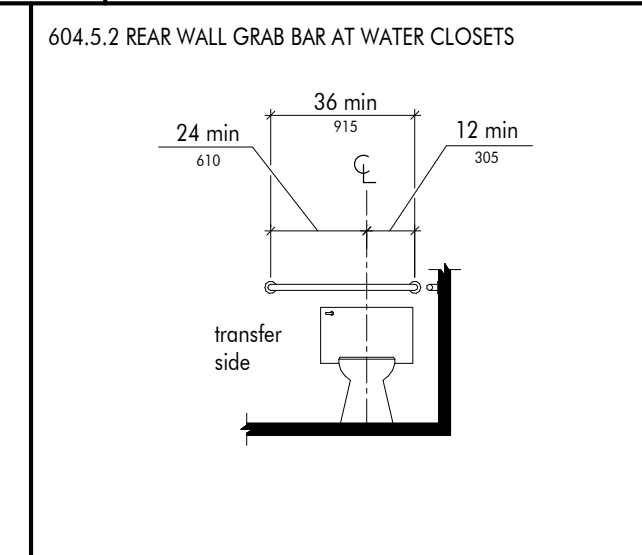
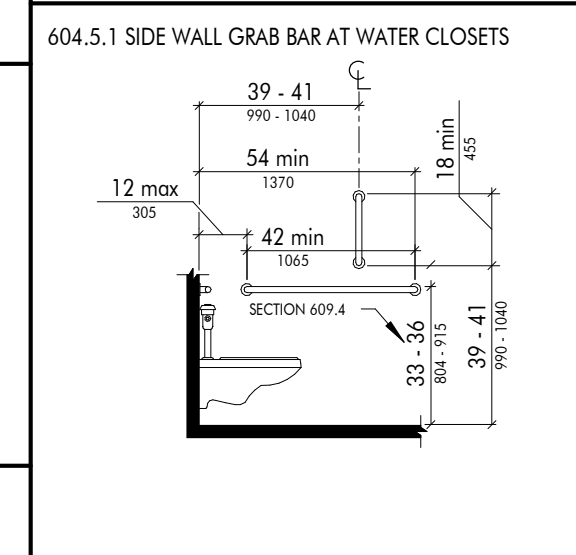
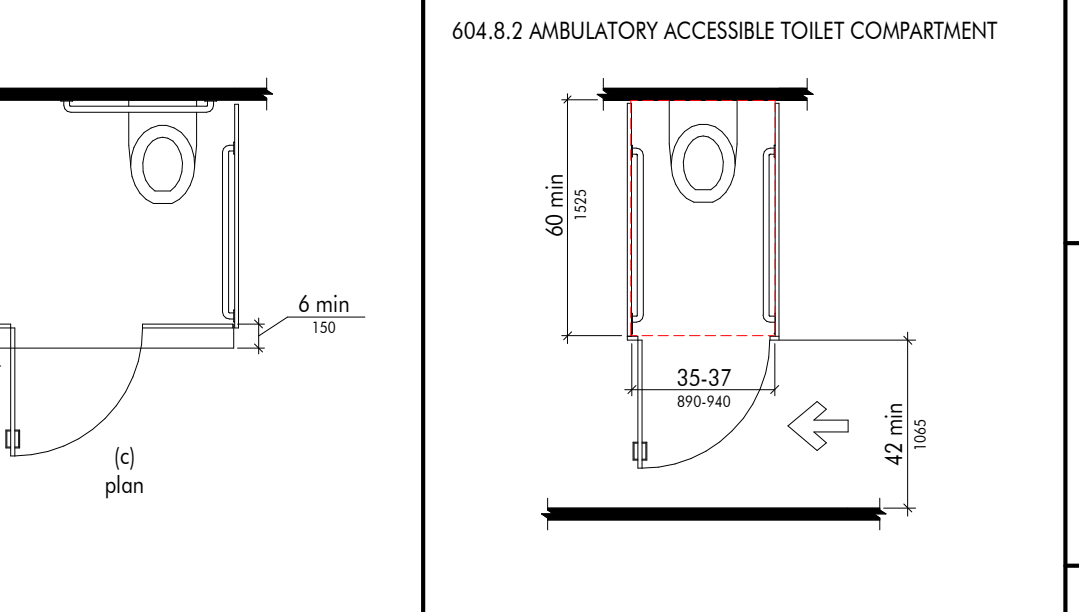
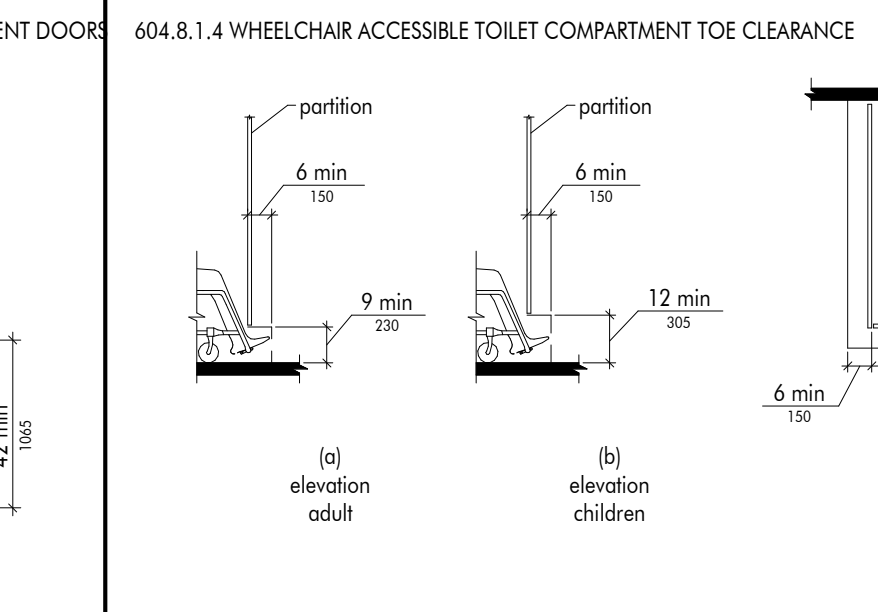
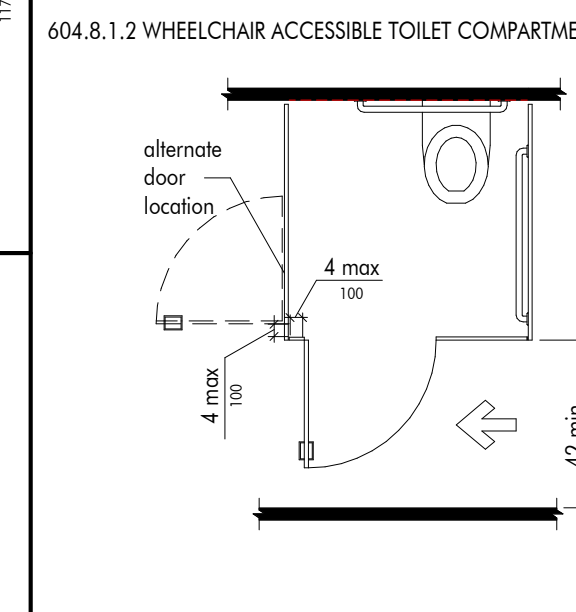
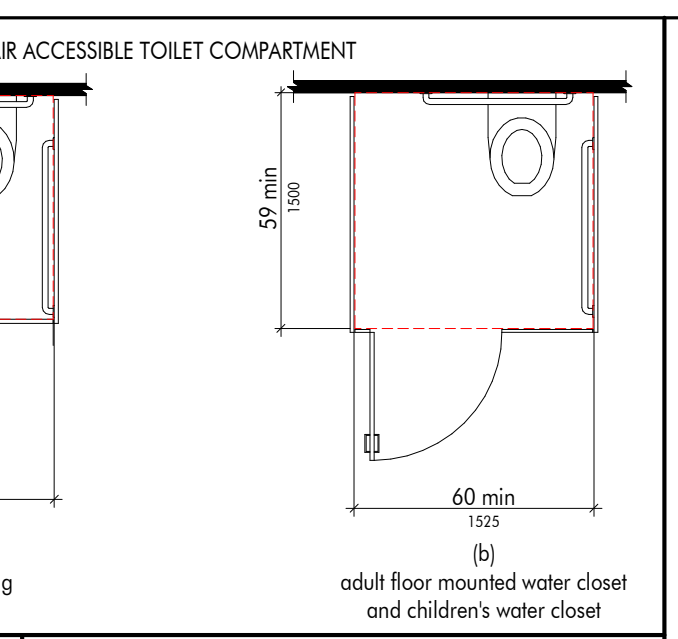
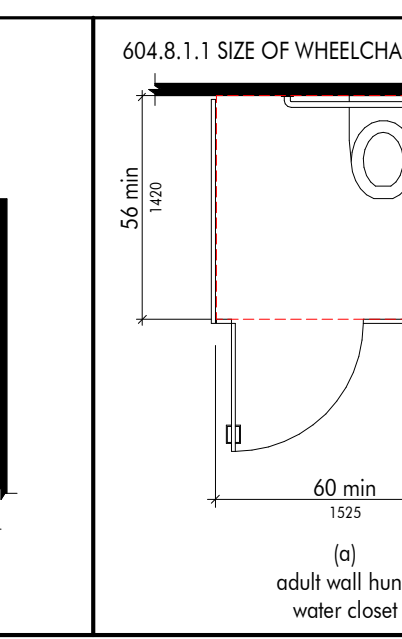
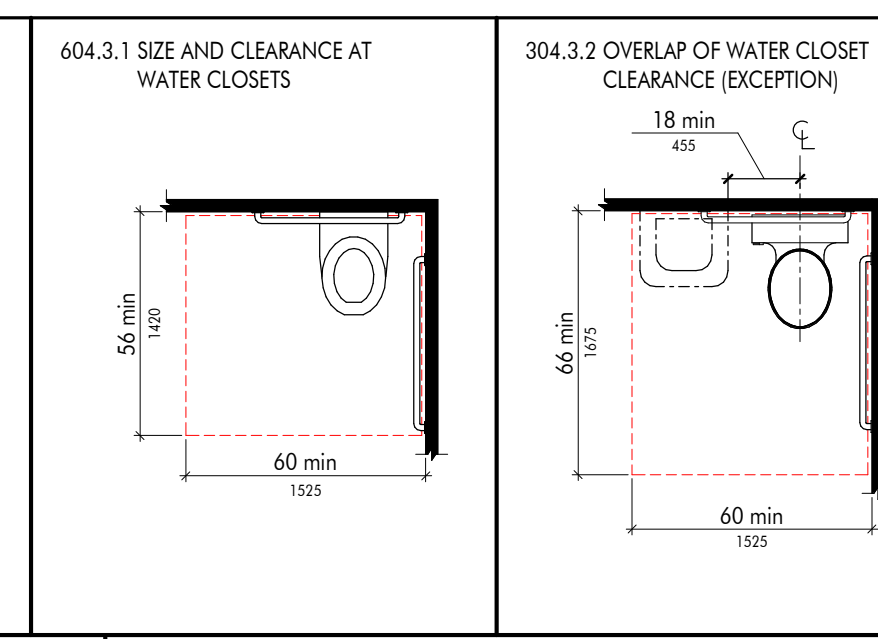
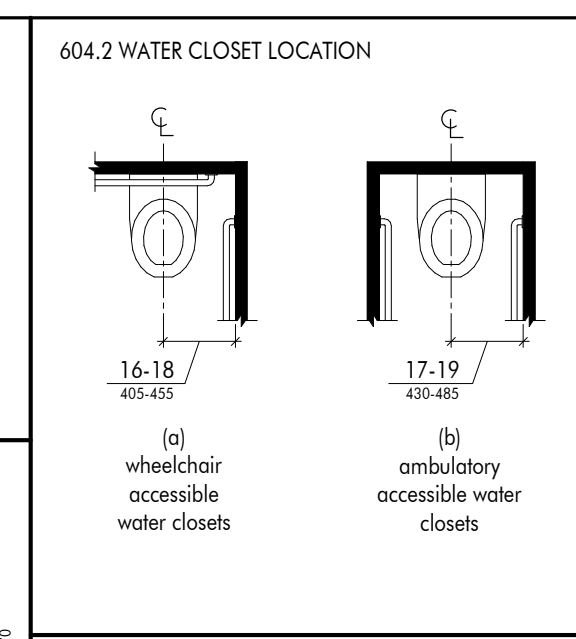
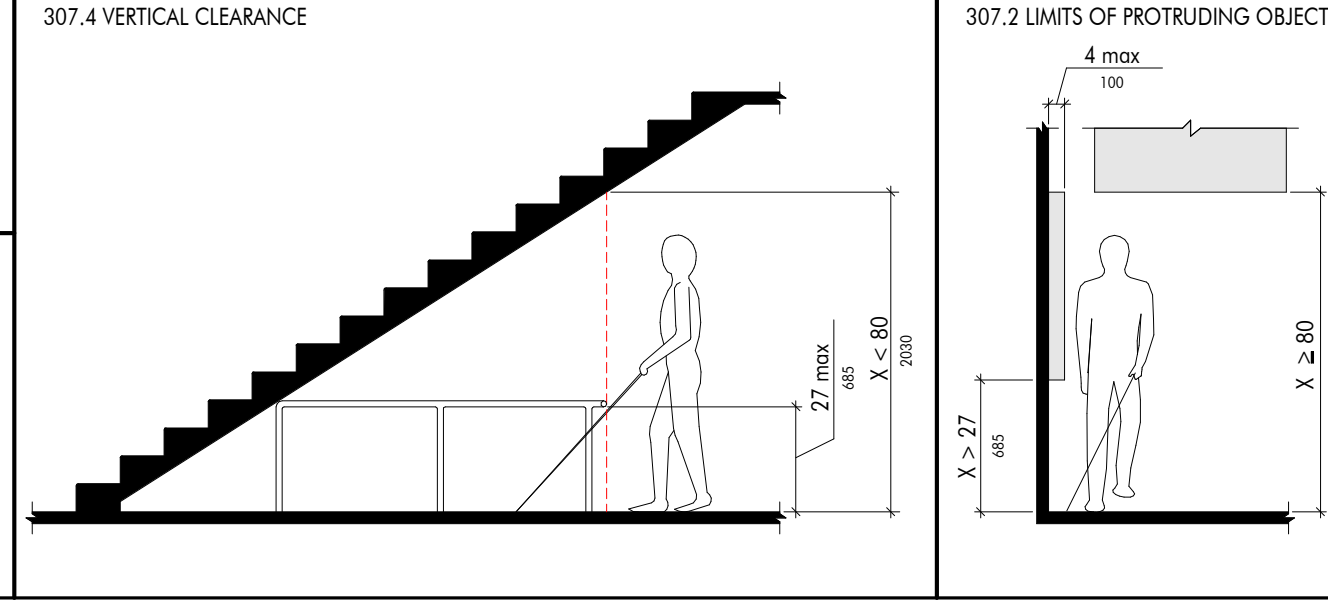
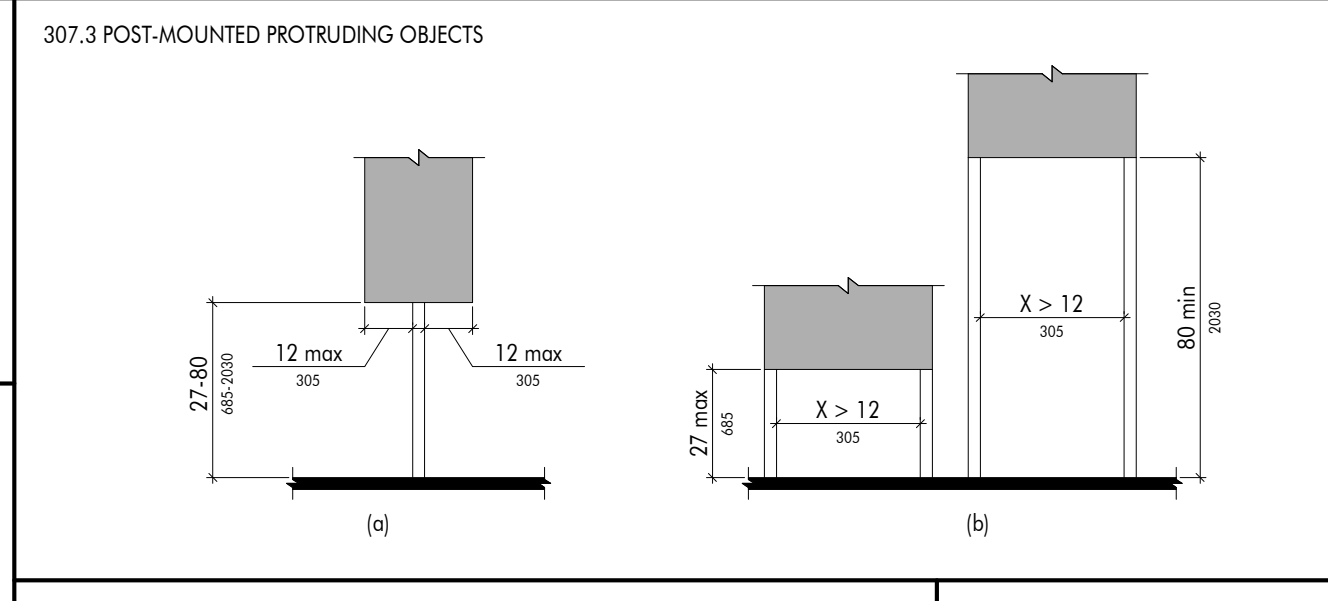
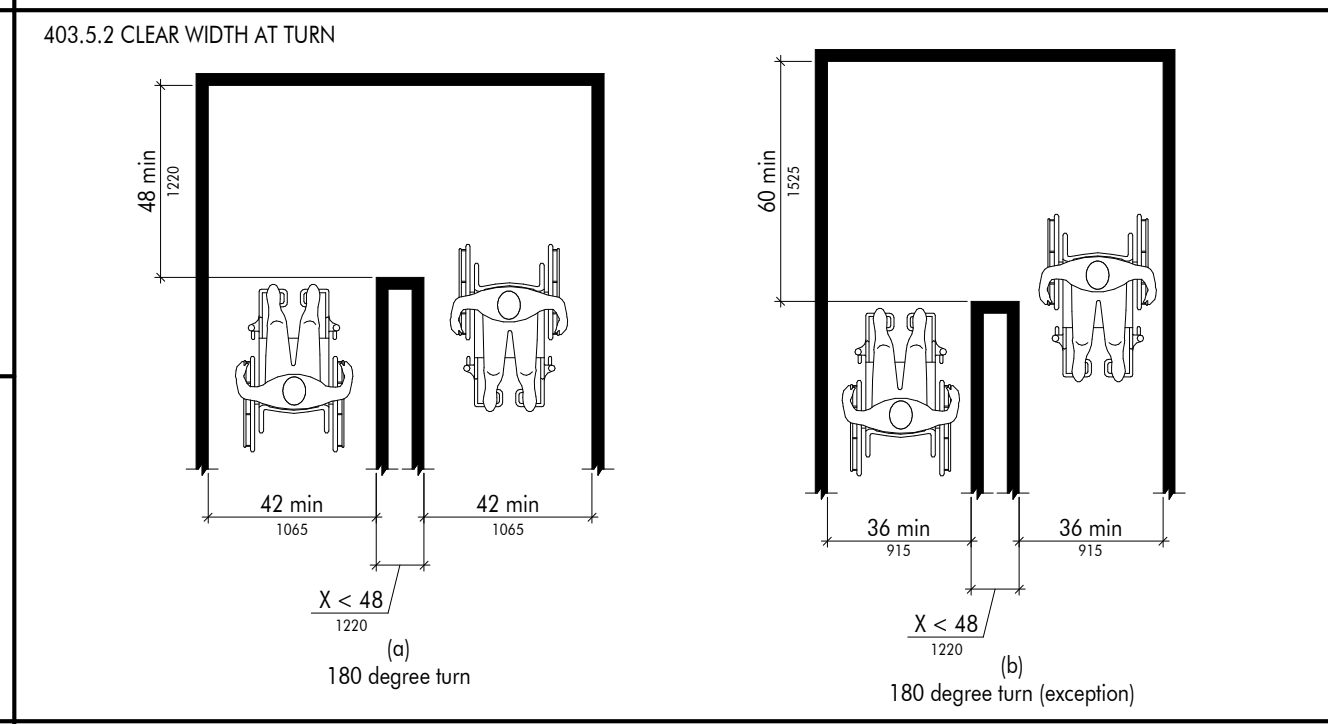
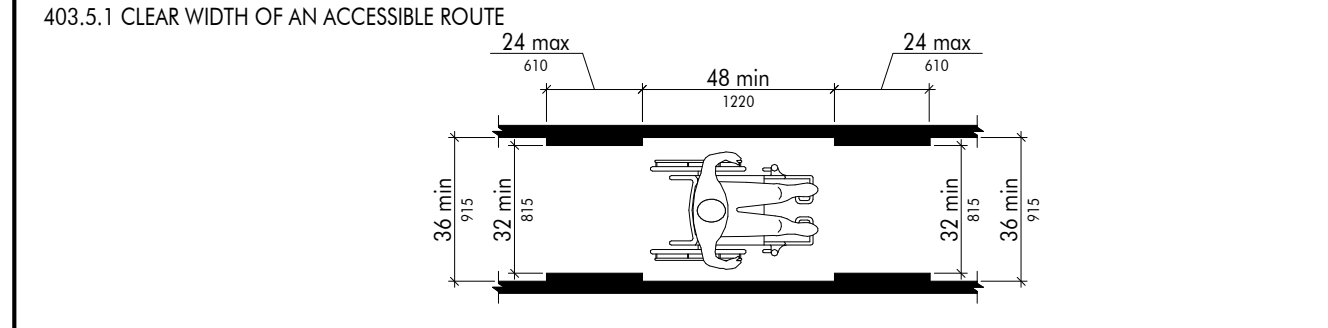
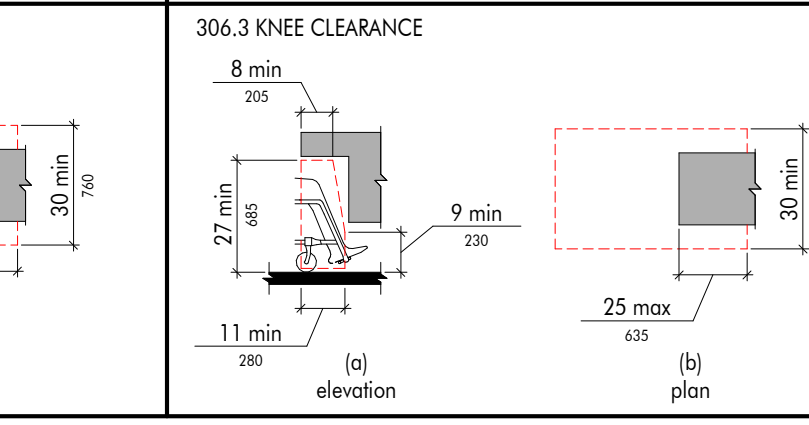
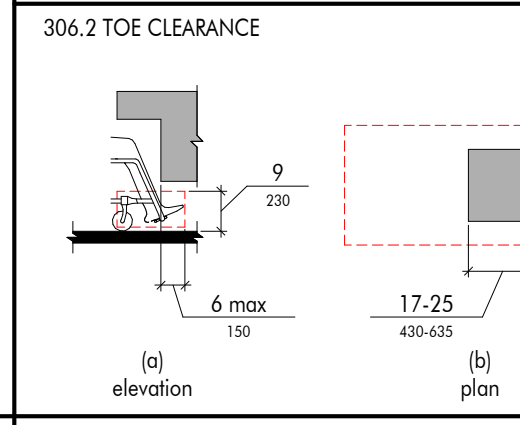
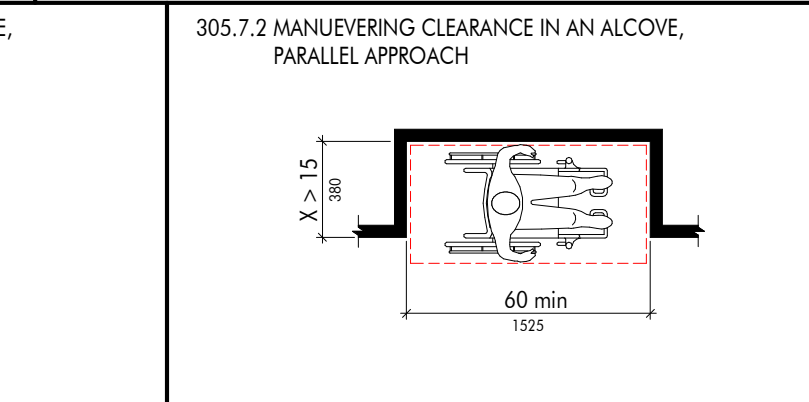
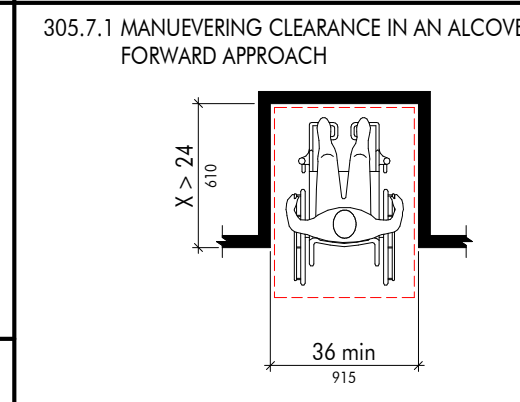
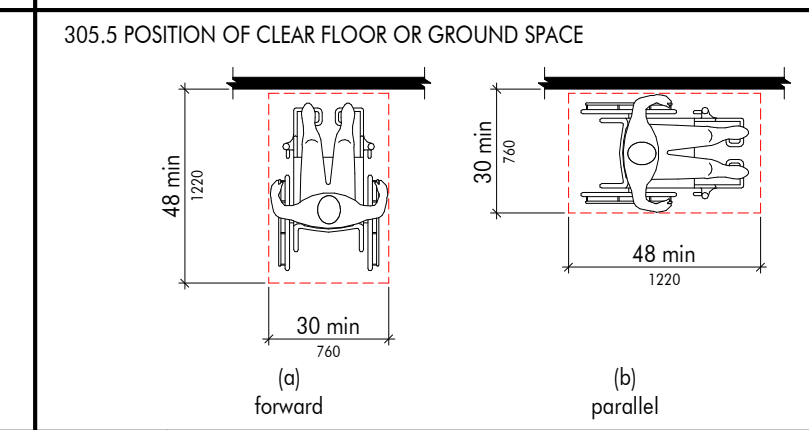
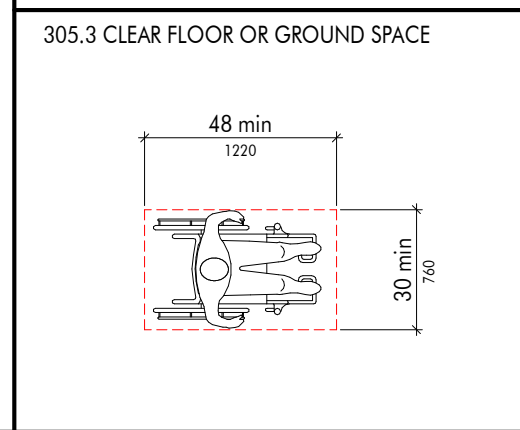
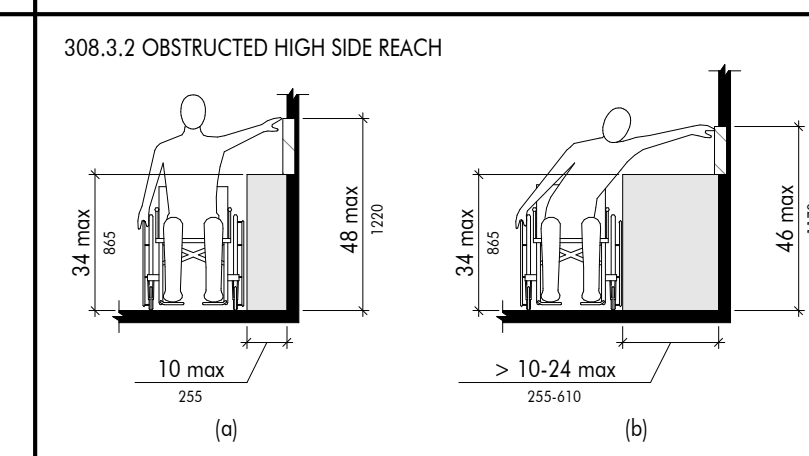
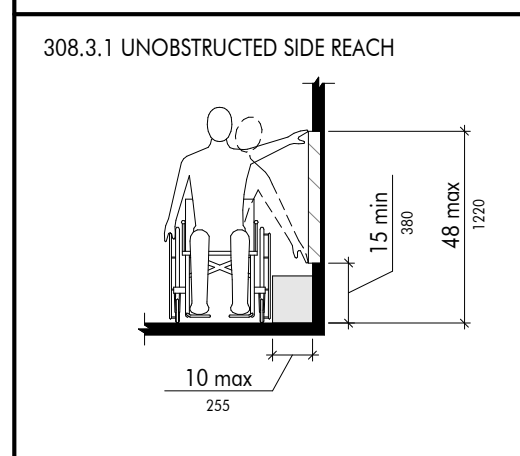
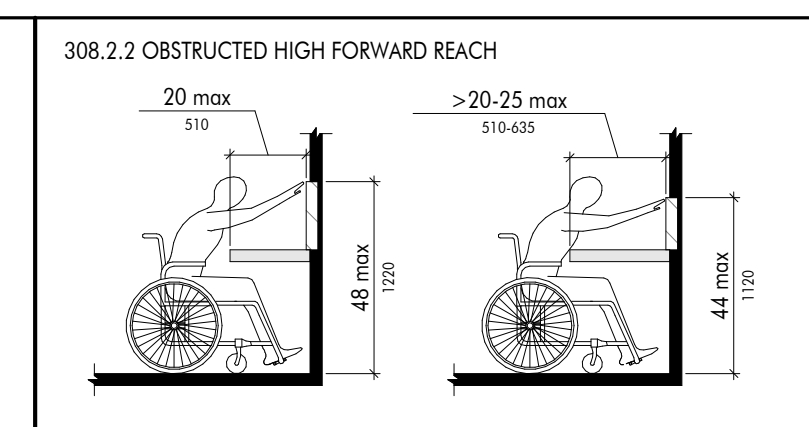
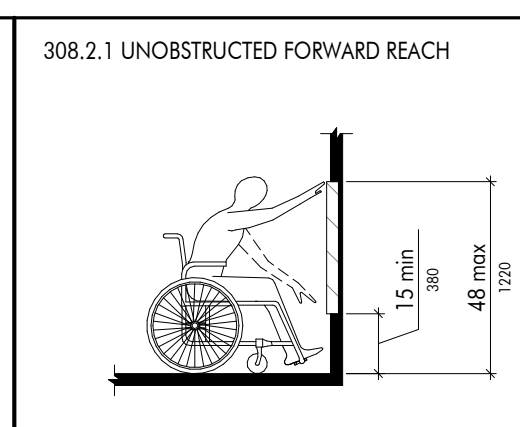
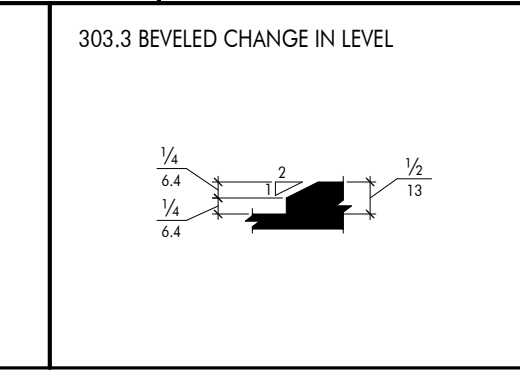
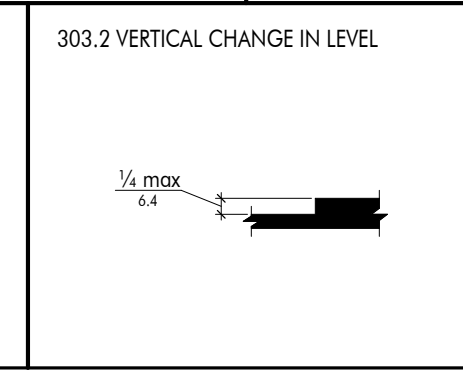
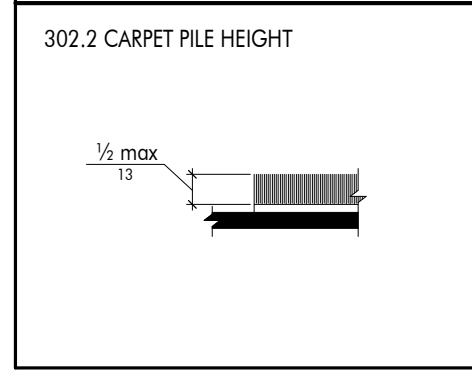
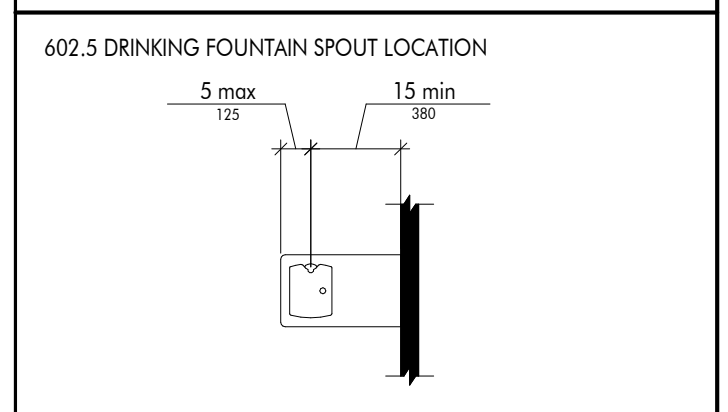
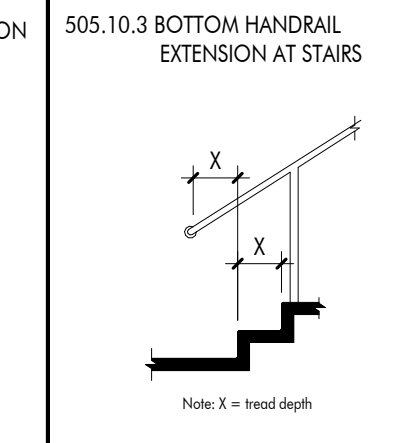
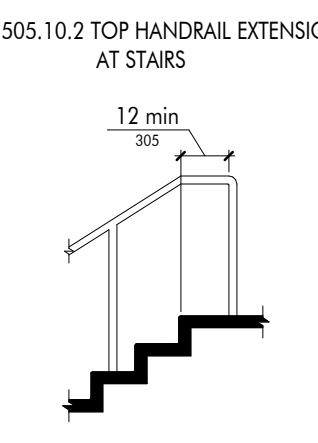
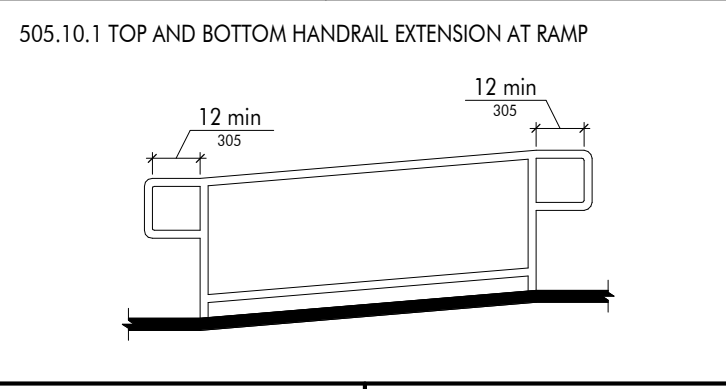
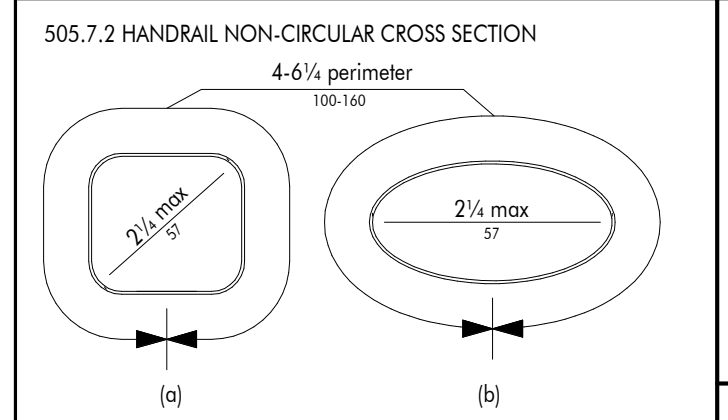
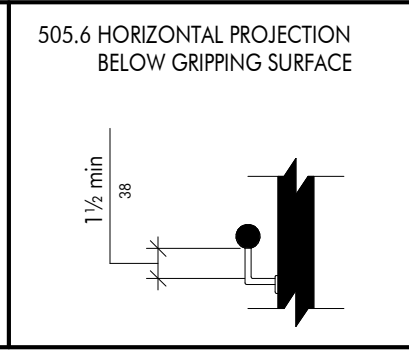
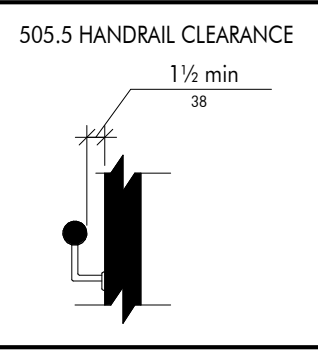
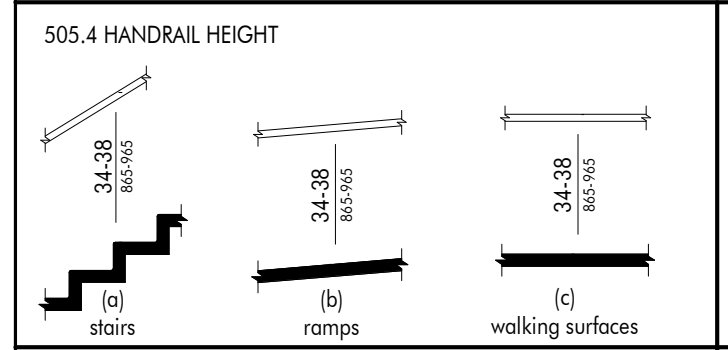
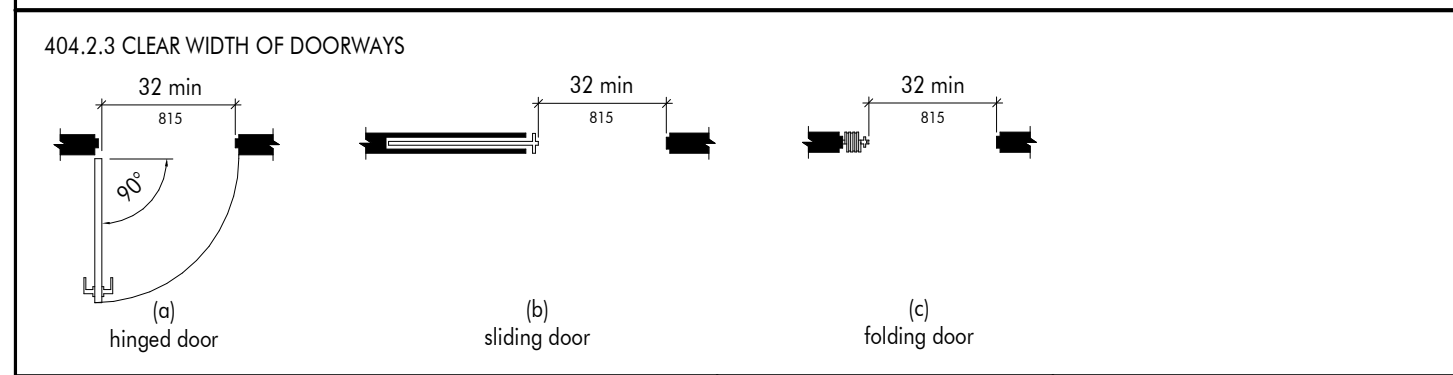
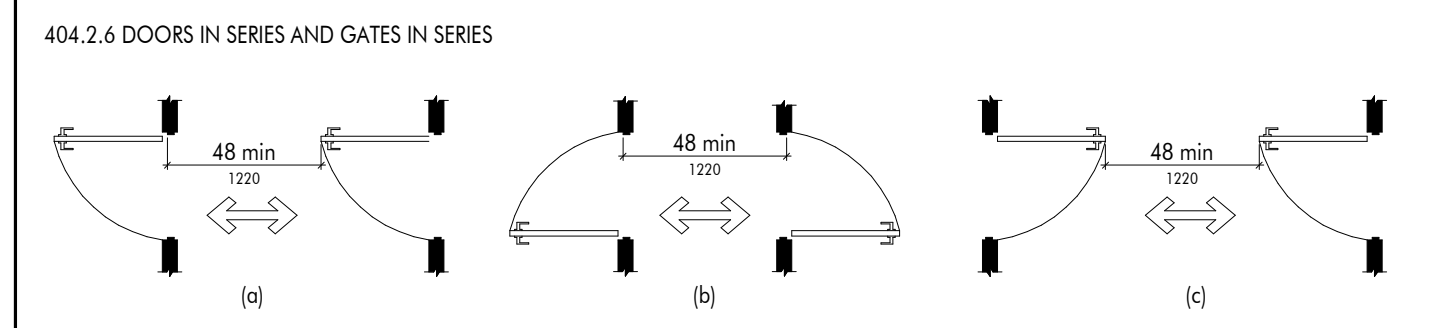
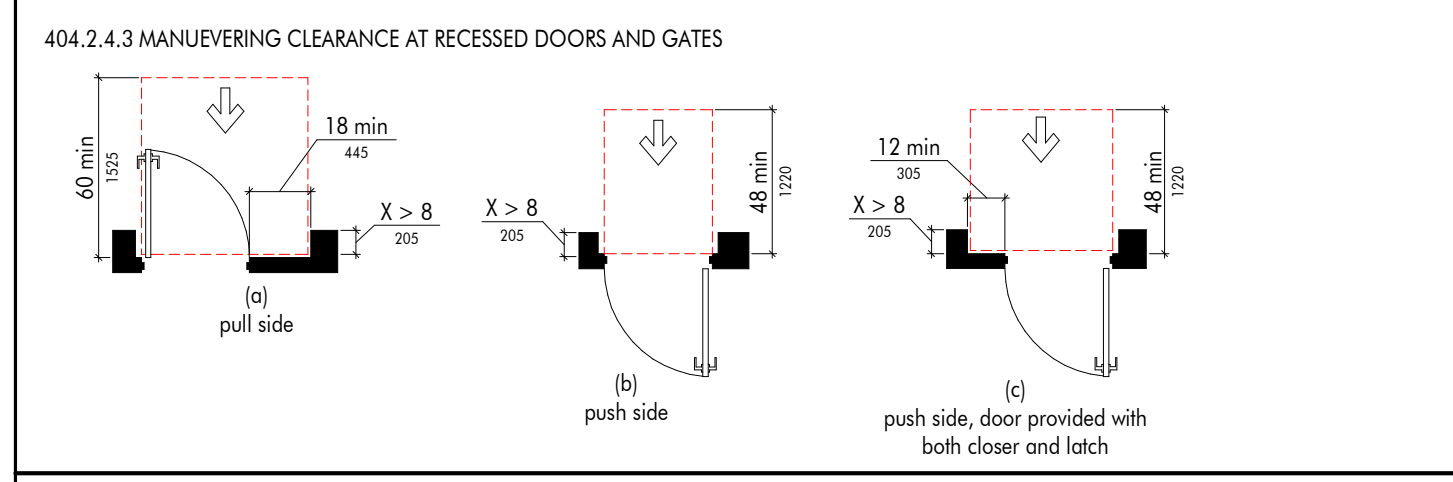
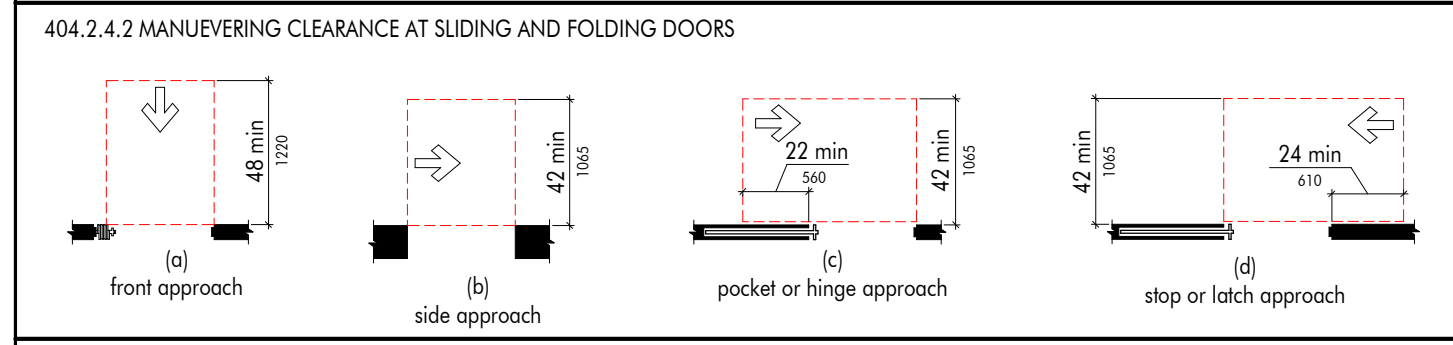
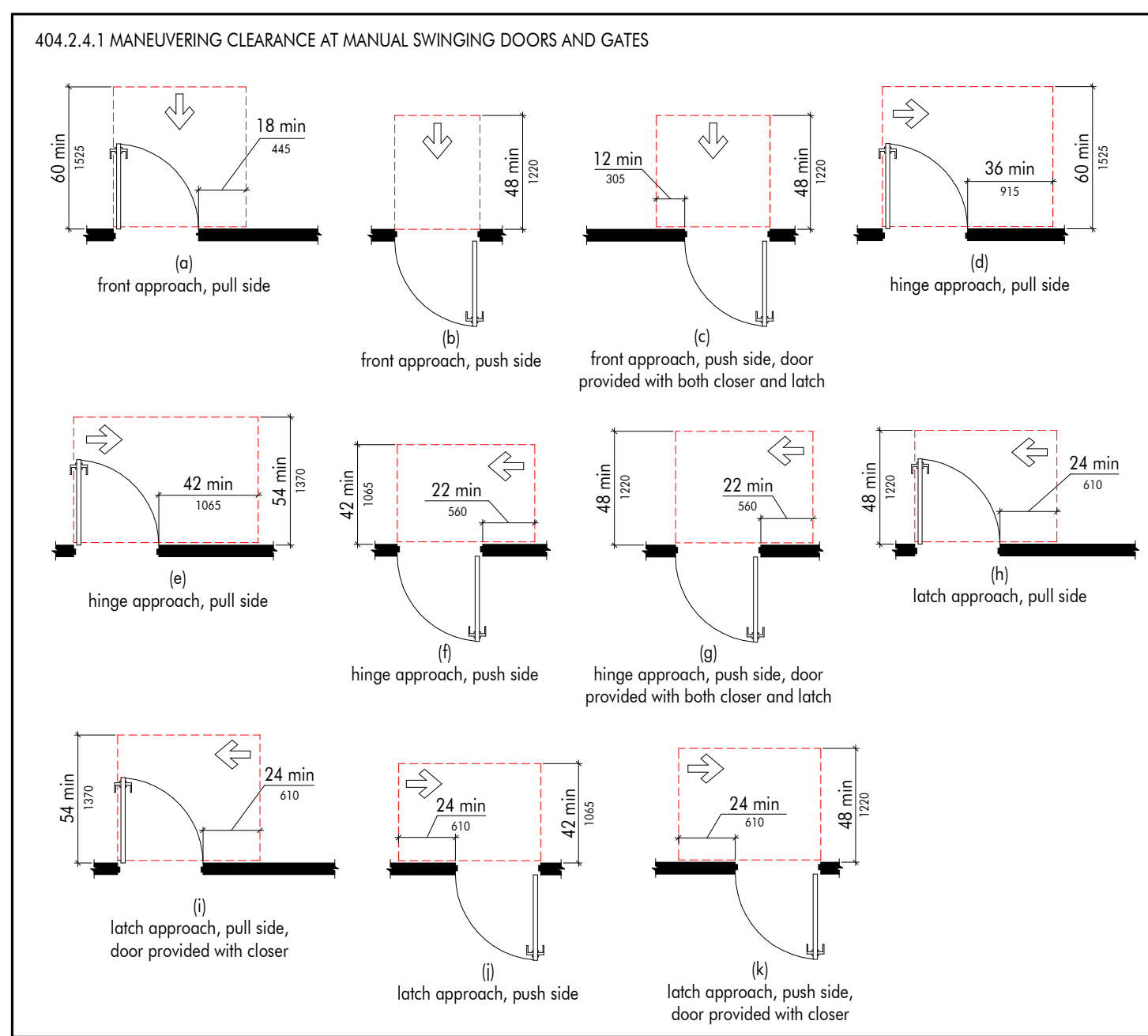

**CONVENTION**

Symbol	Description
	dimension showing English units (2 inches unless otherwise specified); above the line and 51 units (in millimeters unless otherwise specified); below the line
	dimension showing metric units
	dimension showing a range with minimum - maximum
	minimum
	maximum
	greater than or equal to
	less than or equal to
	less than
	boundary of clear floor space or maneuvering clearance
	permitted element or its extension
	direction of travel or approach
	highlighted element in elevation or plan
	location zone of element, control or feature

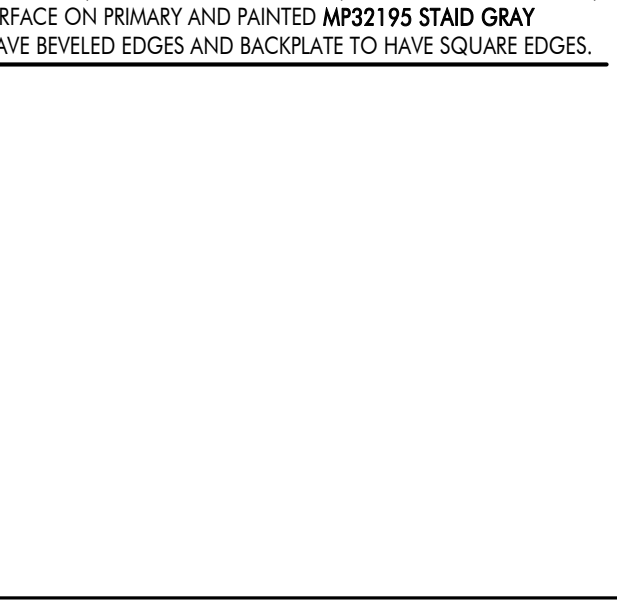
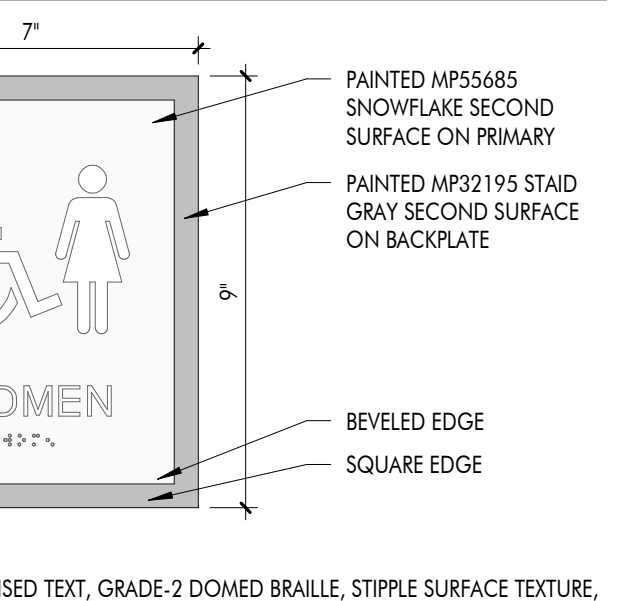
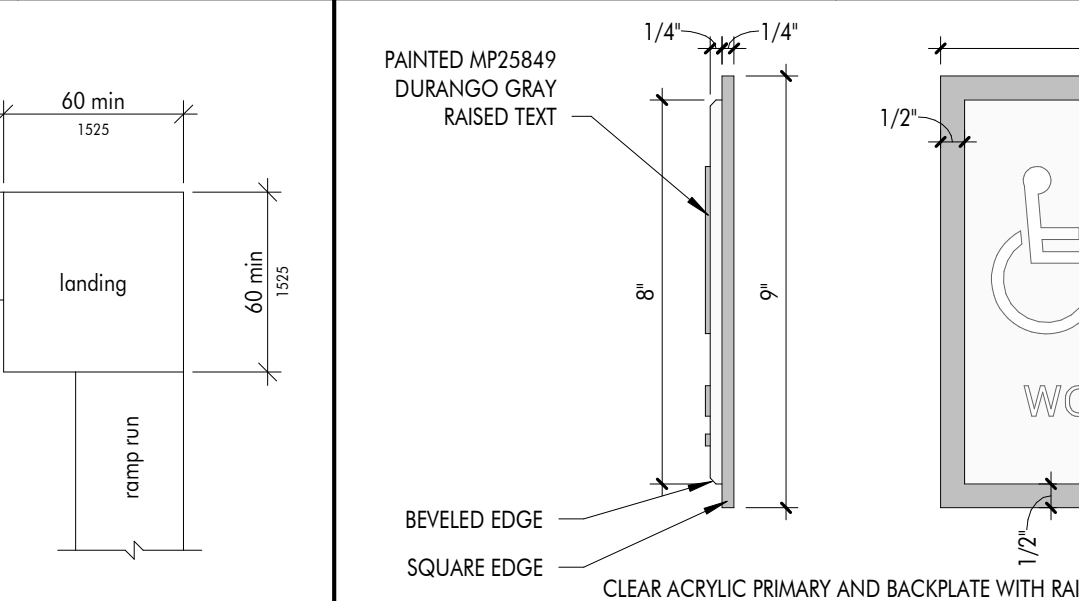
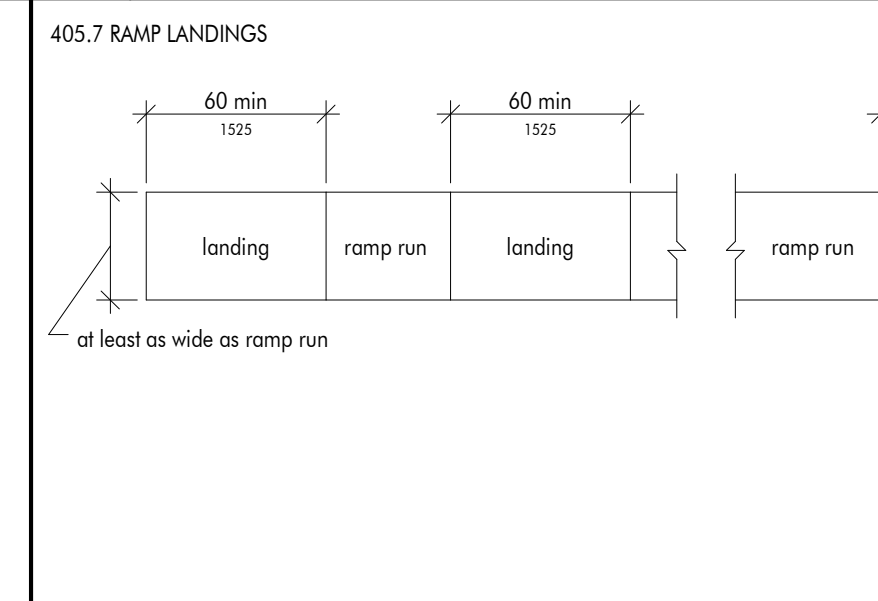
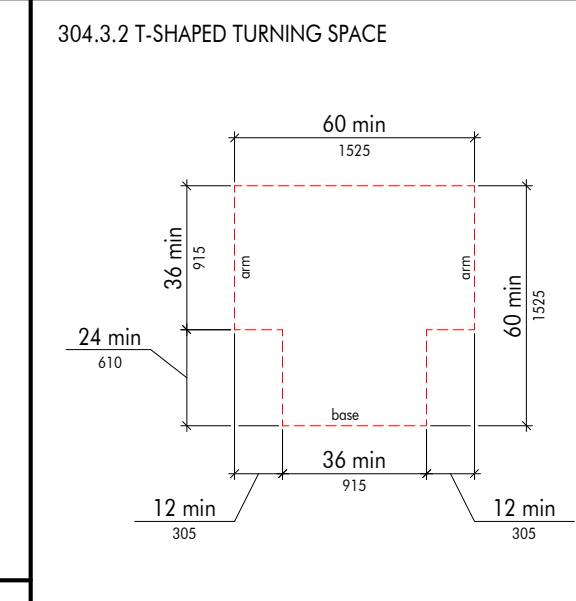
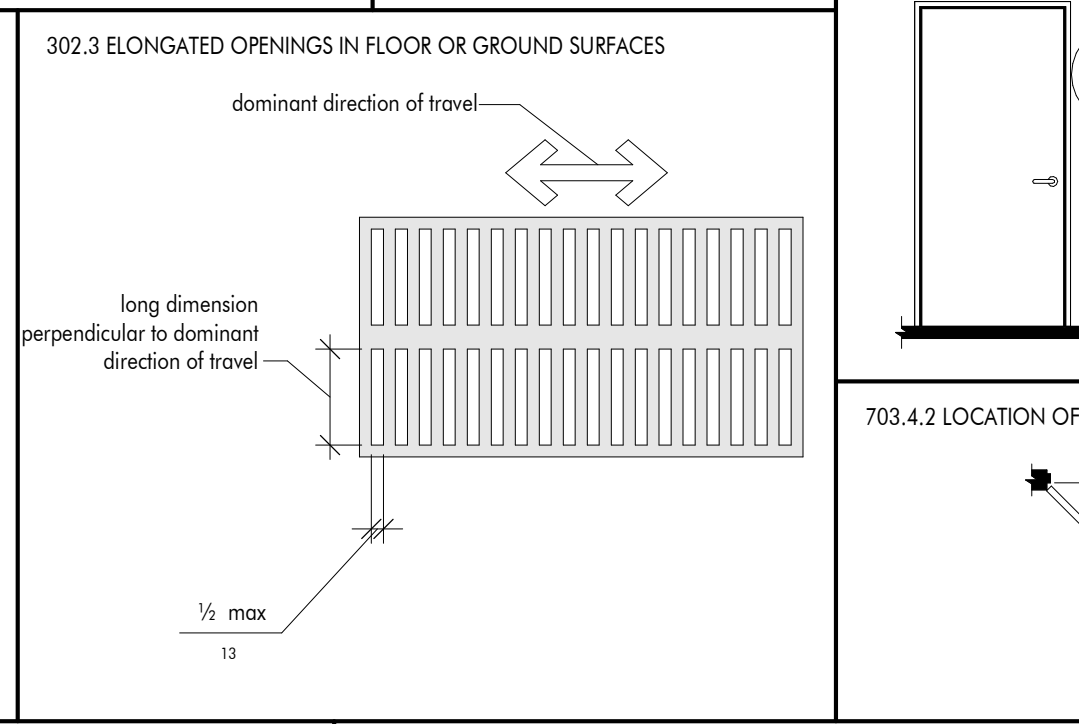
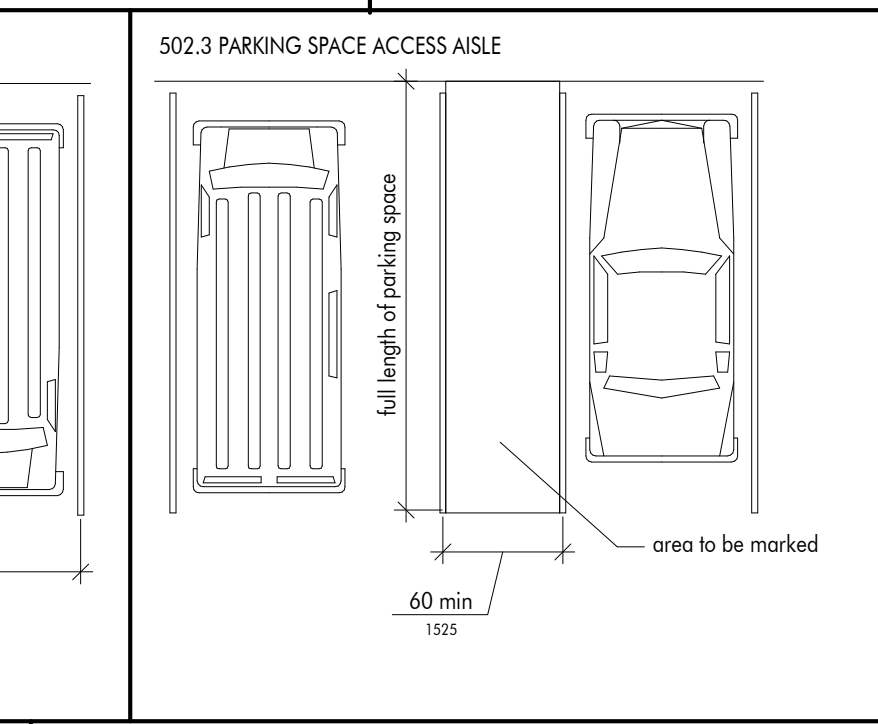
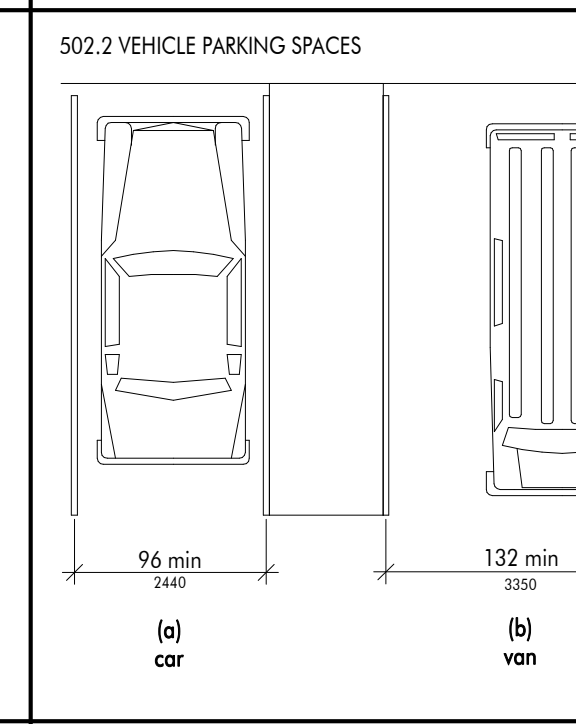
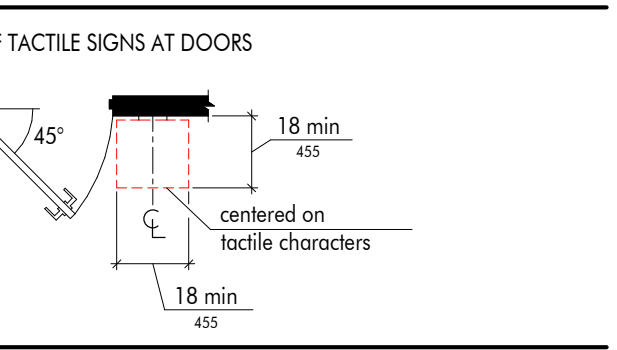
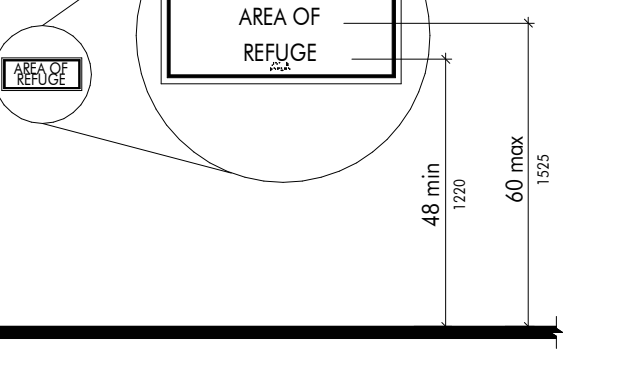
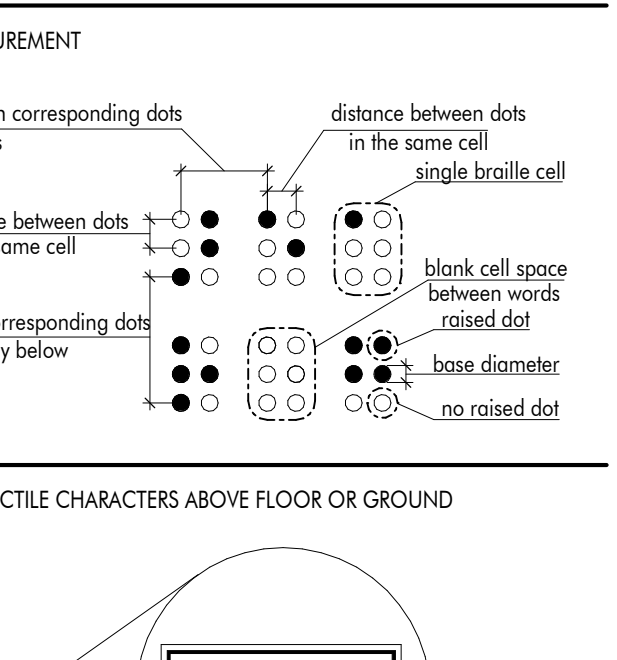
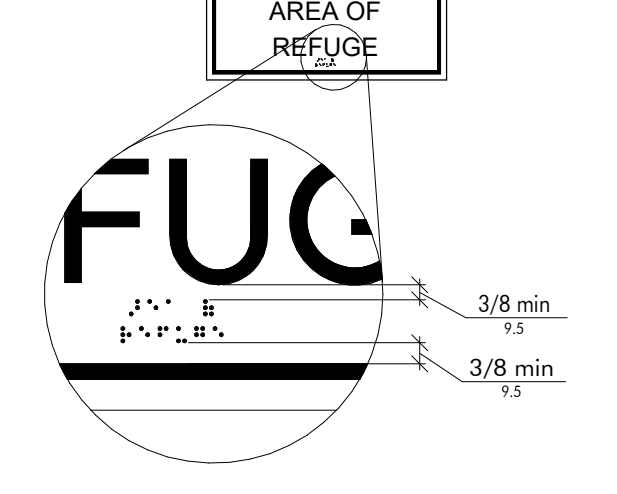
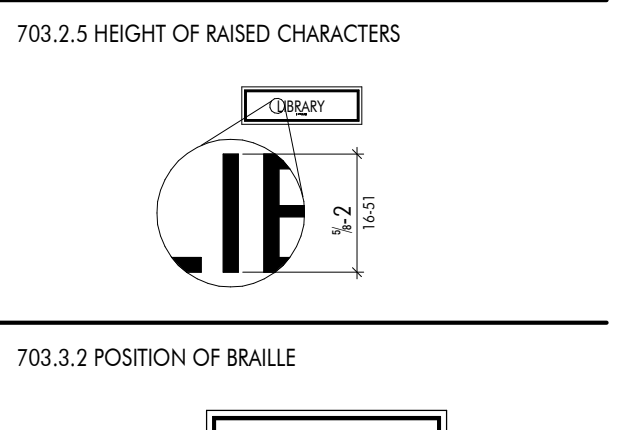

These drawings are the property of DOMAIN ARCHITECTURE APAC and are not to be reproduced in whole or in part. They are only to be used for the project and site specifically identified herein. Scales stated herein are valid on the original drawing only. Contractor shall carefully review all dimensions and conditions shown and report to the architect any errors, inconsistencies, or omissions discovered. These plans were prepared in the office under our personal supervision, and to the best of our knowledge comply with state and local codes. We will generally administer construction.

**CLIENT**

**Southern University Laboratory School**  
**RESTROOM RENOVATIONS**  
 129 SWAN AVE,  
 BATON ROUGE, LA 70813

**PROJECT INFORMATION**

No.	Date	Description

project # **C22-0072**  
 date **AUGUST 31, 2023**  
 director review  
**ADA INFO**  
**11.00**

- 1 THE CONTRACTOR SHALL NOTE: THE SCOPE OF WORK AND WORK ITEMS INCLUDED WITHIN THESE DOCUMENTS, INCLUDING THE DRAWING SHEETS AND SHEET NOTES, SPECIFICATION SECTIONS, AND GENERAL NOTES ARE A PART OF THE SCOPE OF ENVIRONMENTAL WORK FOR THIS PROJECT AND ALL WORK SHALL BE PERFORMED USING WORKMANSHIP-LIKE METHODS. THE CONTRACTOR SHALL NOTE: THIS SCOPE OF WORK, THE REMOVAL OF ASBESTOS-CONTAINING MATERIALS, LEAD-CONTAINING COATINGS AND PAINTS, OLDER LIGHTING FIXTURES BALLASTS AND MERCURY-CONTAINING LAMPS AND SWITCHES SHALL BE REMOVED BY THE ENVIRONMENTAL CONTRACTOR.
- 2 THE CONTRACTOR SHALL NOTE: ELECTRICAL SERVICE PANELS AND EQUIPMENT WILL REMAIN ENERGIZED THROUGH OUT FOR THE DURATION OF THE ENVIRONMENTAL PHASE OF THE WORK FOR THE CONTRACTORS USE AND SHALL BE PROTECTED. THE CONTRACTOR SHALL COORDINATE WITH THE GENERAL RENOVATION CONTRACTOR IN ADVANCE, PRIOR TO DISCONNECTING POWER TO THE WORK AREA AND PRIOR TO PERFORMING WORK. THE CONTRACTOR SHALL UTILIZE A LICENSED ELECTRICIAN TO LOCKOUT /TAGOUT ELECTRICAL TO THE WORK AREAS.
- 3 THE CONTRACTOR SHALL REMOVE AND RELOCATE ANY REMAINING BUILDING CONTENTS FOUND WITHIN THE DESIGNATED WORK AREA RESTROOM LOCATIONS. THE CONTRACTOR SHALL COORDINATE IN ADVANCE WITH THE GENERAL RENOVATION CONTRACTOR PRIOR TO THE REMOVAL OF BUILDING CONTENTS OR EQUIPMENT.
- 4 THE CONTRACTOR SHALL NOTE: PIPING EXISTS WITHIN THE WALL AND CEILING CAVITIES ARE WRAPPED WITH INSULATION DETERMINED PREVIOUSLY TO CONTAIN ASBESTOS. PRIOR TO THE IMPACT OF THESE MATERIALS, THE INSULATION AND RELATED MATERIALS SHALL BE REMOVED AND DISPOSED OF IN ACCORDANCE WITH SECTIONS 02 82 10 AND 02 82 40. PERMANENTLY SEAL OPENS OF PIPING INSULATION.
- 5 THE CONTRACTOR SHALL REMOVE THE CERAMIC TILE FLOOR AND WALL, SETTING BED TO ACCESS, REMOVE AND DISPOSE OF THE WATERPROOFING AND MASTIC LAYERS TO STRUCTURAL CONCRETE AND PLASTER SUBSTRATES. THE CONTRACTOR SHALL DISPOSE OF THE WATERPROOFING MATERIALS AND MASTIC LAYER AS ASBESTOS-CONTAINING IN ACCORDANCE WITH SECTIONS 02 82 10 AND 02 82 40. REMAINING MATERIALS NOT CONTAINING THE MASTIC/WATERPROOFING MATERIALS MAY BE DISPOSED OF AS CONSTRUCTION DEBRIS. THE CONTRACTOR SHALL PROTECT PLASTER WALL, STRUCTURAL SLAB AND DOORWAY THRESHOLD AND ADJACENT ROOM FLOOR TILES FROM DAMAGE.
- 6 THE CONTRACTOR SHALL REMOVE RESTROOM LAVATORIES, URINAL, MIRRORS, PARTITIONS, PLUMBING FIXTURES, FLOOR AND WALL MOUNTED RADIATORS (WITHIN THE GYM RESTROOMS) AND SUSPENDED CEILING (WITHIN THE HIGH SCHOOL BUILDING) TO ACCESS AND REMOVE CERAMIC WALL AND FLOOR SURFACES. COORDINATE WITH THE GENERAL CONTRACTOR PRIOR TO REMOVAL AND DISPOSAL OF ANY PLUMBING FIXTURE OR ITEMS SUPPORTED BY THE WALLS OR CEILING
- 7 THE CONTRACTOR SHALL SAW CUT THE SLAB TO CREATE OPENING AND ROUTING FOR NEW DRAINPIPPS WITHIN THE STORAGE ROOM MEN AND WOMEN'S RESTROOMS. THE CONTRACTOR SHALL REMOVE WATERPROOFING LAYERS AND DISPOSE OF IN ACCORDANCE WITH SECTIONS 02 82 10 AND 02 82 40.
- 8 THE CONTRACTOR SHALL REMOVE PIPING INSULATION FOR THE NEW STORAGE ROOM MEN AND WOMEN'S RESTROOMS, APPROXIMATELY 12 LF FOR EACH TO THE POINT OF TIE-ON OF THE WATER SERVICE AND DISPOSE OF IN ACCORDANCE WITH SECTIONS 02 82 10 AND 02 82 40. PERMANENTLY SEAL OPENS OF PIPING INSULATION.
- 9 THE CONTRACTOR SHALL REMOVE THE SUSPENDED CEILING SYSTEM, INSULATION BATTS AND MATERIALS AND EQUIPMENT SUPPORTED BY THE CEILING AND GRID THROUGH OUT AND DISPOSE OF THESE MATERIALS FROM THE BUILDING. CEILING MATERIALS AND CERTAIN BUILDING CONTENTS MAY CONTAIN DEBRIS MATERIALS FROM DAMAGED ASBESTOS-CONTAINING PIPING INSULATION MATERIALS; THE CONTRACTOR SHALL DISPOSE OF THESE MATERIALS AS ASBESTOS-CONTAINING IN ACCORDANCE WITH SECTIONS 02 82 10 AND 02 82 40. PROTECT FIRE ALARM DEVICES AND SYSTEM.
- 10 THE CONTRACTOR SHALL REMOVE THE CAULK FROM THE DOOR, DOOR FRAME AND RELATED TRANSOMS TO BUILDING SURFACES AND DISPOSE OF AS ASBESTOS-CONTAINING MATERIALS IN ACCORDANCE WITH SECTIONS 02 82 10 AND 02 82 40. PROTECT DOOR AND DOOR FRAME FROM DAMAGE.
- 11 THE CONTRACTOR SHALL REMOVE THE THERMAL SYSTEM INSULATION AND RELATED CAULKING AND MASTIC MATERIALS ON PIPING WITHIN THE RESTROOM CEILING THAT MAY BE IMPACTED BY THE WORK AND DISPOSE OF AS ASBESTOS-CONTAINING MATERIAL IN ACCORDANCE WITH SECTIONS 02 82 10 AND 02 82 40. CONTRACTOR SHALL NOTE: REMOVE PIPING INSULATION MATERIALS WHERE THEY EXIST THROUGH OUT THE RESTROOM CEILING CAVITY AND SEAL THE OPEN ENDS OF THE INSULATION AS IT LEAVES THE WORK AREA. THE CONTRACTOR SHALL COORDINATE IN ADVANCE WITH THE GENERAL RENOVATION CONTRACTOR PRIOR TO THE REMOVAL OF ANY PIPING INSULATION REMOVAL.
- 12 THE CONTRACTOR SHALL REMOVE LOOSE PAINT, SAND AND SMOOTH DOOR, DOOR FRAMES, STOREFRONT AND WALLS AND CEILINGS AND DISPOSE OF AS LEAD-CONTAINING PAINT IN ACCORDANCE WITH SECTION 02 83 19. THE CONTRACTOR SHALL PREPARE AND PRIME DESIGNATED SURFACES WITH AN APPROVED METAL PRIMER TWO COATS SANDING AND SMOOTHING BETWEEN PRIMER COATS.
- 13 THE CONTRACTOR SHALL REMOVE THE OLDER FLUORESCENT LIGHTING FIXTURES AND DISPOSE OF THE OLDER BALLASTS AS PCB-CONTAINING IN ACCORDANCE WITH SECTION 02 83 40. THE REMAINING FIXTURE MAY BE DISPOSED OF AS CONSTRUCTION DEBRIS. RECYCLE WHENEVER POSSIBLE.
- 14 THE CONTRACTOR SHALL REMOVE THE OLDER MERCURY LIGHT TUBES AND DISPOSE OF IN ACCORDANCE WITH SECTION 02 85 00. RECYCLE WHENEVER POSSIBLE.

These drawings are the property of DOMAIN ARCHITECTURE APAC and are not to be reproduced in whole or in part. They are only to be used for the project and site specifically identified herein. Scales stated herein are valid on the original drawings only. Contractor shall carefully review all dimensions and conditions shown and report to the architect any errors, inconsistencies, or omissions discovered. These plans were prepared in this office under our personal supervision, and to the best of our knowledge comply with state and local codes. We will generally administer construction.

Southern University Laboratory School  
**RESTROOM RENOVATIONS**

129 SWAN STREET,  
BATON ROUGE, LA 70813

ENVIRONMENTAL ENGINEER  
RAYNER CONSULTING GROUP, LLC  
7353 HIGHLAND RD, SUITE B-38  
BATON ROUGE, LA 70808  
225.916.2824

MECHANICAL ENGINEER  
ADG BATON ROUGE, LLC  
5071 TEDDY DRIVE  
BATON ROUGE, LA 70809  
225.293.9474

revisions	No.	Description	Date

date: August 31, 2023  
director review: HR

**LEGEND:**

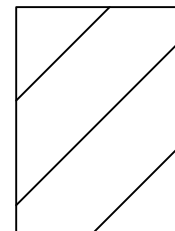
 DENOTES THE REMOVAL AND DISPOSAL OF CERAMIC TILE WALLS AND FLOORING SETTING BED, WATERPROOFING MATERIALS TO SMOOTH PLASTER AND CONCRETE SURFACES; PIPING THERMAL SYSTEM INSULATION, PAINT REPAIR, SANDING SMOOTHING AND PRIMING AND THE REMOVAL AND DISPOSAL OF THE OLDER PCB-CONTAINING BALLASTS, MERCURY-CONTAINING LIGHT TUBES, WINDOW AND TRANSOM GLAZING AND FRAME CAULK, DOOR FRAME CAULK (MATERIALS DESCRIBED WITHIN THE SHEET NOTES 1 THROUGH 14).

 DENOTES THE SHEET NOTE NUMBER AND SCOPE OF WORK.



ASBESTOS ABATEMENT DESIGNER

Harry Rayner 8/31/23  
DATE

HARRY RAYNER  
CERTIFICATE NO. AD114982

ENGINEER IS NOT CERTIFYING THE INTEGRITY OF THE STRUCTURAL ELEMENTS OF THE BUILDING INCLUDING THE FOUNDATION DUE TO THIS WORK. STRUCTURAL ANALYSIS IS BY OTHERS. THIS CERTIFICATION IS FOR THE ENVIRONMENTAL ABATEMENT ONLY.

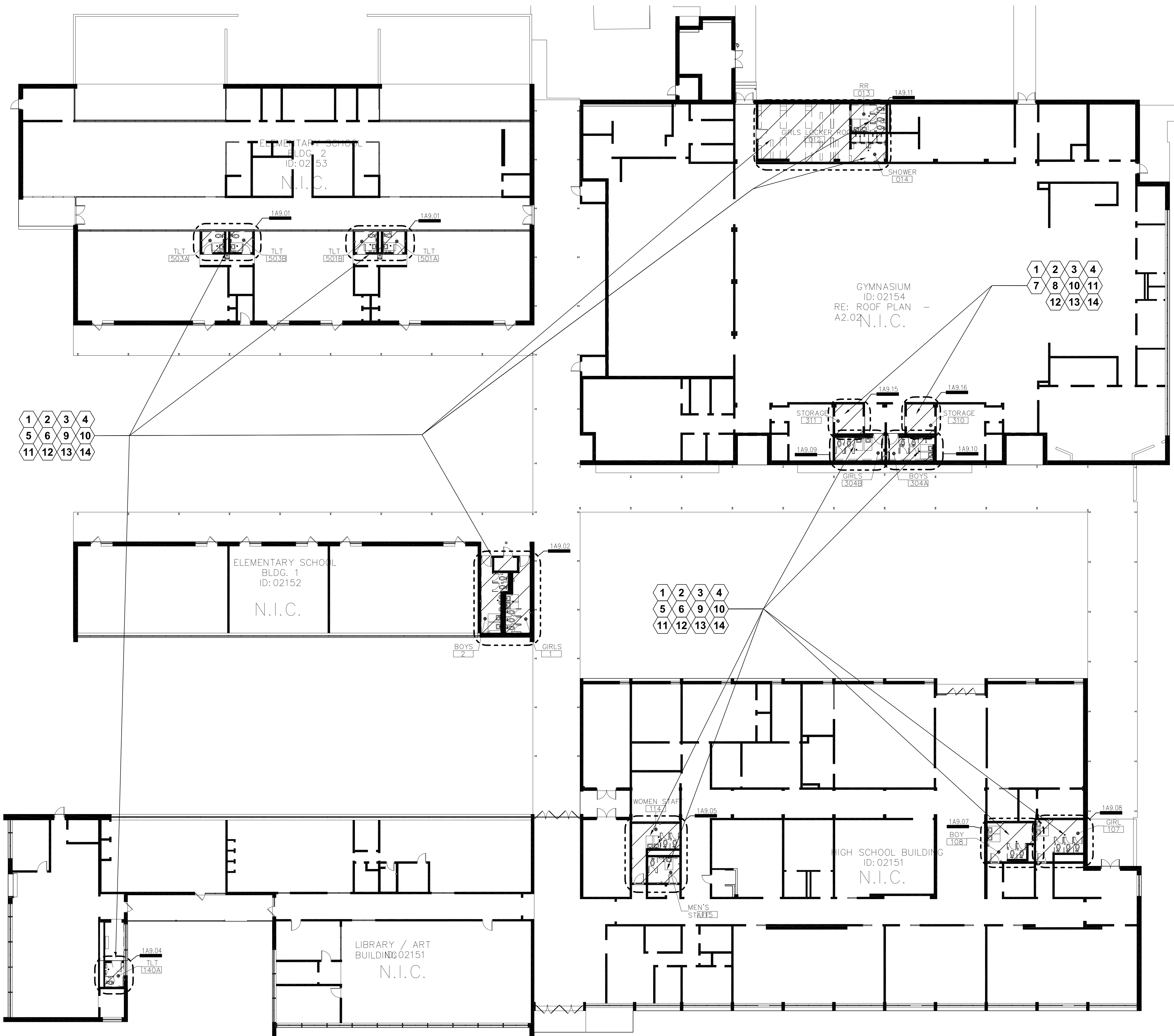

1ST FLOOR – ENVIRONMENTAL DEMOLITION FLOOR PLAN  
1/16" = 1'-0" DRAWN BY:

These drawings are the property of DOMAIN ARCHITECTURE APAC and are not to be reproduced in whole or in part. They are only to be used for the project and site specifically identified herein. Scales stated herein are valid on the original drawings only. Contractor shall carefully review all dimensions and conditions shown and report to the architect any errors, inconsistencies, or omissions discovered. These plans were prepared in this office under our personal supervision, and to the best of our knowledge comply with state and local codes. We will generally administer construction.

Southern University Laboratory School  
**RESTROOM RENOVATIONS**  
129 SWAN STREET,  
BATON ROUGE, LA 70813

ENVIRONMENTAL ENGINEER  
RAYNER CONSULTING GROUP, LLC  
7353 HIGHLAND RD, SUITE B-58  
BATON ROUGE, LA 70808  
225.916.2824  
MECHANICAL ENGINEER  
ADG BATON ROUGE, LLC  
5071 TEDDY DRIVE  
BATON ROUGE, LA 70809  
225.293.9474

revisions		
No.	Description	Date

date: August 31, 2023  
director review: HR

EV1.02

**SOUTHERN UNIVERSITY LABORATORY SCHOOL RESTROOM RENOVATION SHEET NOTES:**

- 1 THE CONTRACTOR SHALL NOTE: THE SCOPE OF WORK AND WORK ITEMS INCLUDED WITHIN THESE DOCUMENTS, INCLUDING THE DRAWING SHEETS AND SHEET NOTES, SPECIFICATION SECTIONS, AND GENERAL NOTES ARE A PART OF THE SCOPE OF ENVIRONMENTAL WORK FOR THIS PROJECT AND ALL WORK SHALL BE PERFORMED USING WORKMANSHIP-LIKE METHODS. THE CONTRACTOR SHALL NOTE: THIS SCOPE OF WORK, THE REMOVAL OF ASBESTOS-CONTAINING MATERIALS, LEAD-CONTAINING COATINGS AND PAINTS, OLDER LIGHTING FIXTURES BALLASTS AND MERCURY-CONTAINING LAMPS AND SWITCHES SHALL BE REMOVED BY THE ENVIRONMENTAL CONTRACTOR.
- 2 THE CONTRACTOR SHALL NOTE: ELECTRICAL SERVICE PANELS AND EQUIPMENT WILL REMAIN ENERGIZED THROUGH OUT FOR THE DURATION OF THE ENVIRONMENTAL PHASE OF THE WORK FOR THE CONTRACTORS USE AND SHALL BE PROTECTED. THE CONTRACTOR SHALL COORDINATE WITH THE GENERAL RENOVATION CONTRACTOR IN ADVANCE, PRIOR TO DISCONNECTING POWER TO THE WORK AREA AND PRIOR TO PERFORMING WORK. THE CONTRACTOR SHALL UTILIZE A LICENSED ELECTRICIAN TO LOCKOUT /TAGOUT ELECTRICAL TO THE WORK AREAS.
- 3 THE CONTRACTOR SHALL REMOVE AND RELOCATE ANY REMAINING BUILDING CONTENTS FOUND WITHIN THE DESIGNATED WORK AREA RESTROOM LOCATIONS. THE CONTRACTOR SHALL COORDINATE IN ADVANCE WITH THE GENERAL RENOVATION CONTRACTOR PRIOR TO THE REMOVAL OF BUILDING CONTENTS OR EQUIPMENT.
- 4 THE CONTRACTOR SHALL NOTE: PIPING EXISTS WITHIN THE WALL AND CEILING CAVITIES ARE WRAPPED WITH INSULATION DETERMINED PREVIOUSLY TO CONTAIN ASBESTOS. PRIOR TO THE IMPACT OF THESE MATERIALS, THE INSULATION AND RELATED MATERIALS SHALL BE REMOVED AND DISPOSED OF IN ACCORDANCE WITH SECTIONS 02 82 10 AND 02 82 40. PERMANENTLY SEAL OPENS OF PIPING INSULATION.
- 5 THE CONTRACTOR SHALL REMOVE THE CERAMIC TILE FLOOR AND WALL, SETTING BED TO ACCESS, REMOVE AND DISPOSE OF THE WATERPROOFING AND MASTIC LAYERS TO STRUCTURAL CONCRETE AND PLASTER SUBSTRATES. THE CONTRACTOR SHALL DISPOSE OF THE WATERPROOFING MATERIALS AND MASTIC LAYER AS ASBESTOS-CONTAINING IN ACCORDANCE WITH SECTIONS 02 82 10 AND 02 82 40. REMAINING MATERIALS NOT CONTAINING THE MASTIC/WATERPROOFING MATERIALS MAY BE DISPOSED OF AS CONSTRUCTION DEBRIS. THE CONTRACTOR SHALL PROTECT PLASTER WALL, STRUCTURAL SLAB AND DOORWAY THRESHOLD AND ADJACENT ROOM FLOOR TILES FROM DAMAGE.
- 6 THE CONTRACTOR SHALL REMOVE RESTROOM LAVATORIES, URINAL, MIRRORS, PARTITIONS, PLUMBING FIXTURES, FLOOR AND WALL MOUNTED RADIATORS (WITHIN THE GYM RESTROOMS) AND SUSPENDED CEILING (WITHIN THE HIGH SCHOOL BUILDING) TO ACCESS AND REMOVE CERAMIC WALL AND FLOOR SURFACES. COORDINATE WITH THE GENERAL CONTRACTOR PRIOR TO REMOVAL AND DISPOSAL OF ANY PLUMBING FIXTURE OR ITEMS SUPPORTED BY THE WALLS OR CEILING
- 7 THE CONTRACTOR SHALL SAW CUT THE SLAB TO CREATE OPENING AND ROUTING FOR NEW DRAINPIPES WITHIN THE STORAGE ROOM MEN AND WOMEN'S RESTROOMS. THE CONTRACTOR SHALL REMOVE WATERPROOFING LAYERS AND DISPOSE OF IN ACCORDANCE WITH SECTIONS 02 82 10 AND 02 82 40.
- 8 THE CONTRACTOR SHALL REMOVE PIPING INSULATION FOR THE NEW STORAGE ROOM MEN AND WOMEN'S RESTROOMS, APPROXIMATELY 12 LF FOR EACH TO THE POINT OF TIE-ON OF THE WATER SERVICE AND DISPOSE OF IN ACCORDANCE WITH SECTIONS 02 82 10 AND 02 82 40. PERMANENTLY SEAL OPENS OF PIPING INSULATION.
- 9 THE CONTRACTOR SHALL REMOVE THE SUSPENDED CEILINGS SYSTEM, INSULATION BATTS AND MATERIALS AND EQUIPMENT SUPPORTED BY THE CEILING AND GRID THROUGH OUT AND DISPOSE OF THESE MATERIALS FROM THE BUILDING. CEILING MATERIALS AND CERTAIN BUILDING CONTENTS MAY CONTAIN DEBRIS MATERIALS FROM DAMAGED ASBESTOS-CONTAINING PIPING INSULATION MATERIALS; THE CONTRACTOR SHALL DISPOSE OF THESE MATERIALS AS ASBESTOS-CONTAINING IN ACCORDANCE WITH SECTIONS 02 82 10 AND 02 82 40. PROTECT FIRE ALARM DEVICES AND SYSTEM.
- 10 THE CONTRACTOR SHALL REMOVE THE CAULK FROM THE DOOR, DOOR FRAME AND RELATED TRANSOMS TO BUILDING SURFACES AND DISPOSE OF AS ASBESTOS-CONTAINING MATERIALS IN ACCORDANCE WITH SECTIONS 02 82 10 AND 02 82 40. PROTECT DOOR AND DOOR FRAME FROM DAMAGE.
- 11 THE CONTRACTOR SHALL REMOVE THE THERMAL SYSTEM INSULATION AND RELATED CAULKING AND MASTIC MATERIALS ON PIPING WITHIN THE RESTROOM CEILING THAT MAY BE IMPACTED BY THE WORK AND DISPOSE OF AS ASBESTOS-CONTAINING MATERIAL IN ACCORDANCE WITH SECTIONS 02 82 10 AND 02 82 40. CONTRACTOR SHALL NOTE: REMOVE PIPING INSULATION MATERIALS WHERE THEY EXIST THROUGH OUT THE RESTROOM CEILING CAVITY AND SEAL THE OPEN ENDS OF THE INSULATION AS IT LEAVES THE WORK AREA. THE CONTRACTOR SHALL COORDINATE IN ADVANCE WITH THE GENERAL RENOVATION CONTRACTOR PRIOR TO THE REMOVAL OF ANY PIPING INSULATION REMOVAL.
- 12 THE CONTRACTOR SHALL REMOVE LOOSE PAINT, SAND AND SMOOTH DOOR, DOOR FRAMES, STOREFRONT AND WALLS AND CEILINGS AND DISPOSE OF AS LEAD-CONTAINING PAINT IN ACCORDANCE WITH SECTION 02 83 19. THE CONTRACTOR SHALL PREPARE AND PRIME DESIGNATED SURFACES WITH AN APPROVED METAL PRIMER TWO COATS SANDING AND SMOOTHING BETWEEN PRIMER COATS.
- 13 THE CONTRACTOR SHALL REMOVE THE OLDER FLUORESCENT LIGHTING FIXTURES AND DISPOSE OF THE OLDER BALLASTS AS PCB-CONTAINING IN ACCORDANCE WITH SECTION 02 83 40. THE REMAINING FIXTURE MAY BE DISPOSED OF AS CONSTRUCTION DEBRIS. RECYCLE WHENEVER POSSIBLE.
- 14 THE CONTRACTOR SHALL REMOVE THE OLDER MERCURY LIGHT TUBES AND DISPOSE OF IN ACCORDANCE WITH SECTION 02 85 00. RECYCLE WHENEVER POSSIBLE.

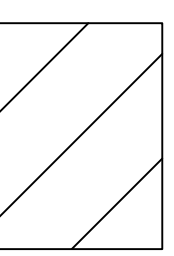
**LEGEND:**  
 DENOTES THE REMOVAL AND DISPOSAL OF CERAMIC TILE WALLS AND FLOORING SETTING BED, WATERPROOFING MATERIALS TO SMOOTH PLASTER AND CONCRETE SURFACES; PIPING THERMAL SYSTEM INSULATION, PAINT REPAIR, SANDING SMOOTHING AND PRIMING AND THE REMOVAL AND DISPOSAL OF THE OLDER PCB-CONTAINING BALLASTS, MERCURY-CONTAINING LIGHT TUBES, WINDOW AND TRANSOM GLAZING AND FRAME CAULK, DOOR FRAME CAULK (MATERIALS DESCRIBED WITHIN THE SHEET NOTES 1 THROUGH 14).

 DENOTES THE SHEET NOTE NUMBER AND SCOPE OF WORK.

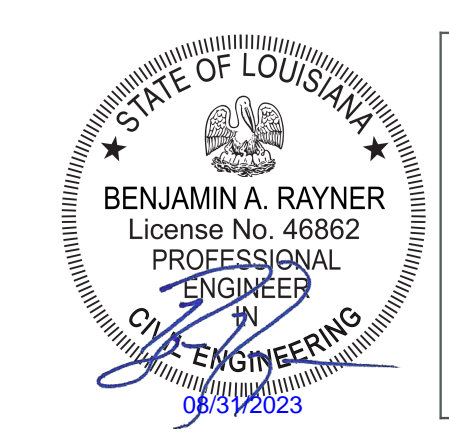

ASBESTOS ABATEMENT DESIGNER  
*Harry Rayner* 8/31/23  
HARRY RAYNER  
CERTIFICATE NO. AD114392

ENGINEER IS NOT CERTIFYING THE INTEGRITY OF THE STRUCTURAL ELEMENTS OF THE BUILDING INCLUDING THE FOUNDATION. DUE TO THIS WORK, STRUCTURAL ANALYSIS IS BY OTHERS. THIS CERTIFICATION IS FOR THE ENVIRONMENTAL ABATEMENT ONLY.

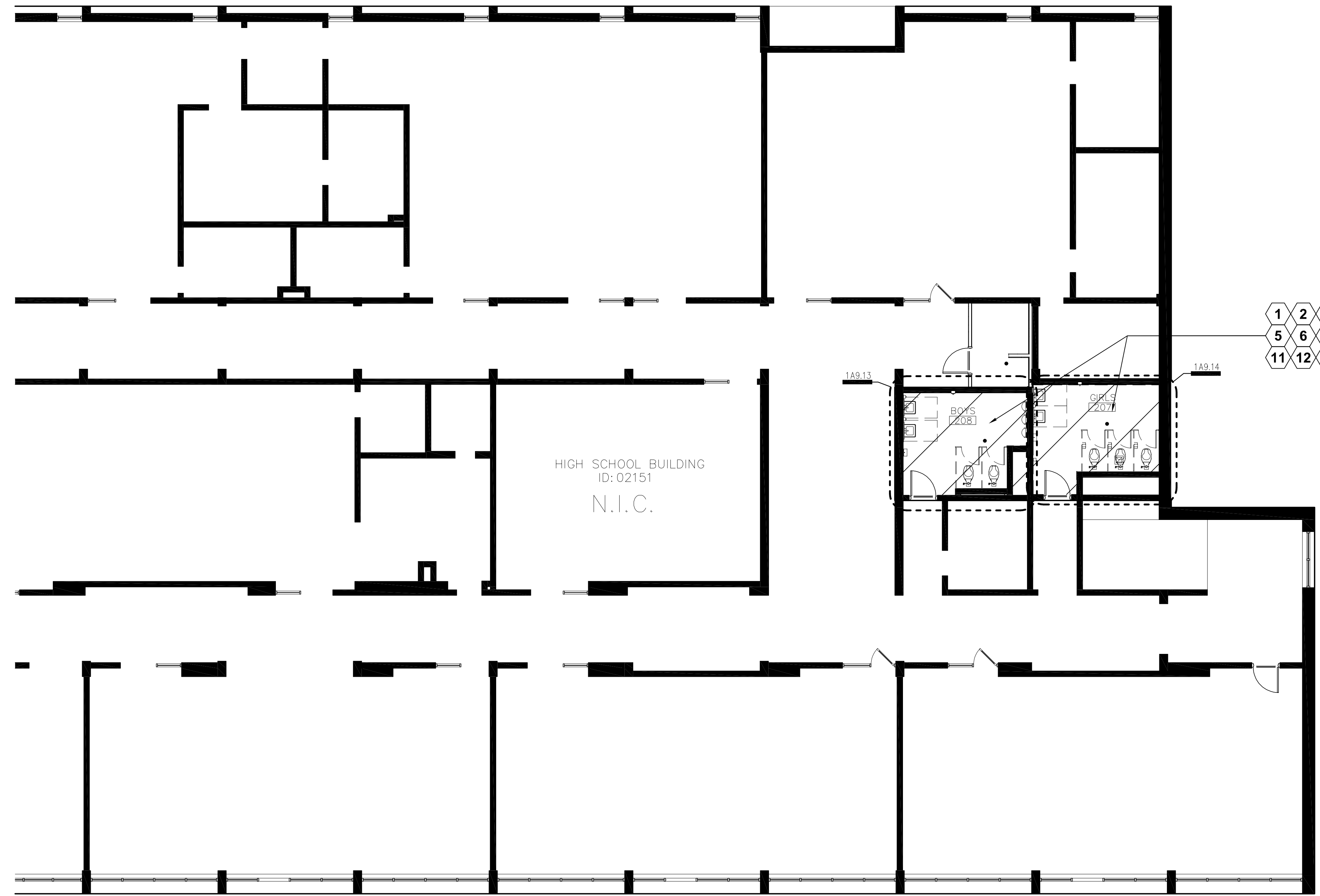

EXHAUST CONTAINMENTS TO BUILDING EXTERIOR

August 31, 2023

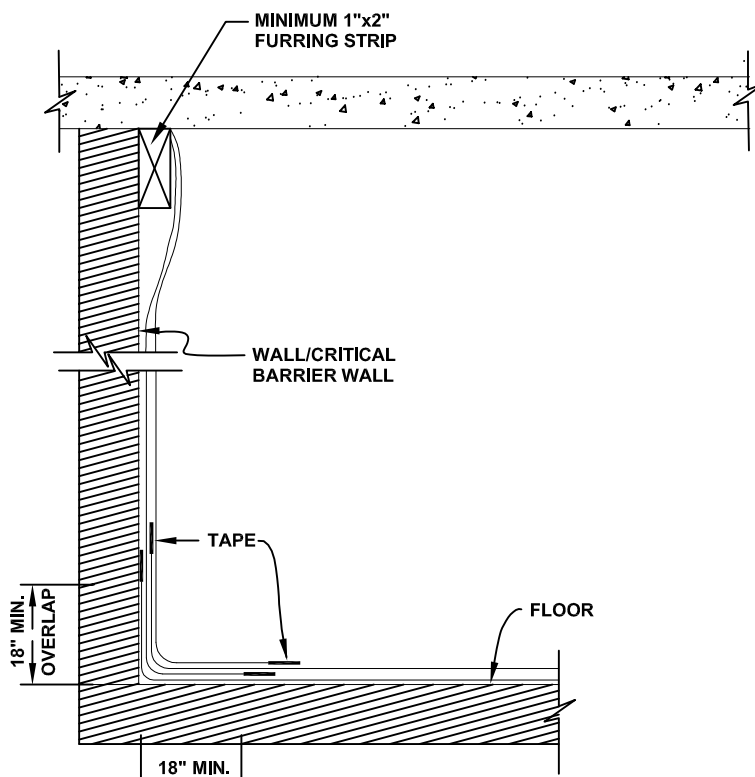

- NOTES:**
1. MINIMUM 2 LAYERS OF 4 MIL POLYSHEETING ON WALLS AND MINIMUM 2 LAYERS OF 6 MIL POLYSHEETING ON FLOORS.
  2. ADDITIONAL LAYERS OF POLYSHEETING, SPRAY POLYSHEETING OR OTHER PROTECTIVE LAYERS MAY BE REQUIRED TO PROTECT BUILDING SURFACE FINISHES AND EQUIPMENT.
  3. ALL MATERIALS SHALL BE FIRE RETARDANT.

**1** INSTALLATION OF POLYSHEETING  
SCALE: N.T.S.

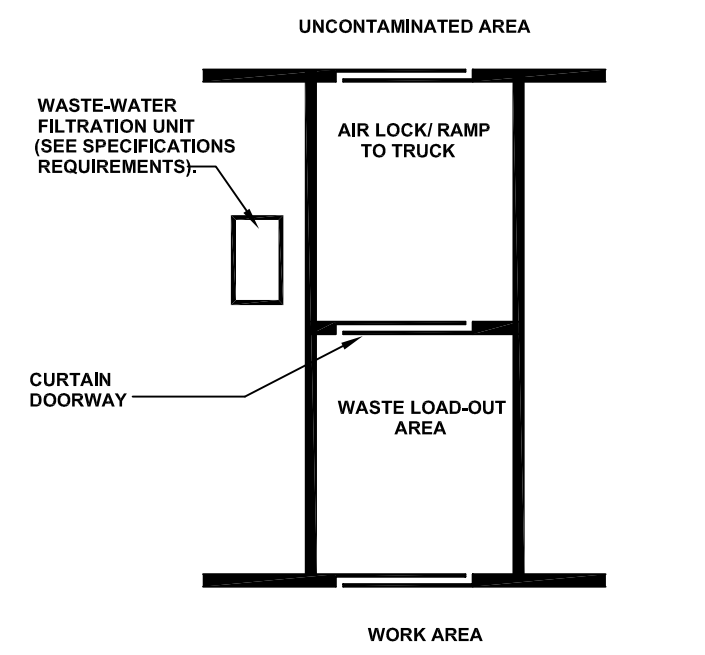

- NOTES:**
1. WORKERS FROM THE UNCONTAMINATED AREA SHALL NOT PROCEED BEYOND THE AIR LOCK.
  2. WORKERS FROM THE WORK AREA SHALL NOT PROCEED BEYOND THE WASTE LOAD-OUT AREA.

**2** EQUIPMENT/MATERIAL DECONTAMINATION ENCLOSURE SYSTEM SCHEMATIC  
SCALE: N.T.S.

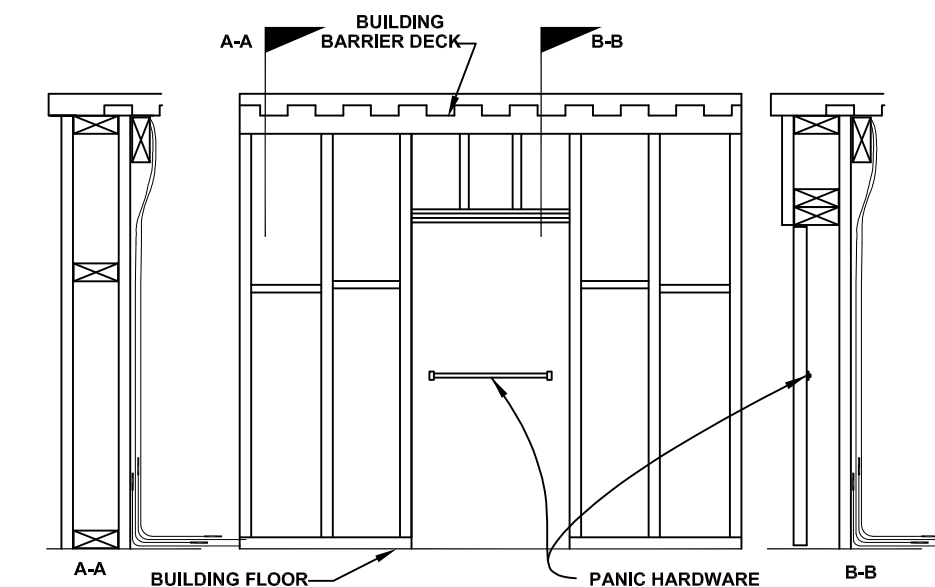

- NOTES:**
1. RIGID BARRIER WALL MATERIALS SHALL BE FIRE-RETARDANT, 2x4 STUDWALL CONSTRUCTION, 24\"/>

**3** RIGID BARRIER WALL WITH EMERGENCY EXIT  
SCALE: N.T.S.

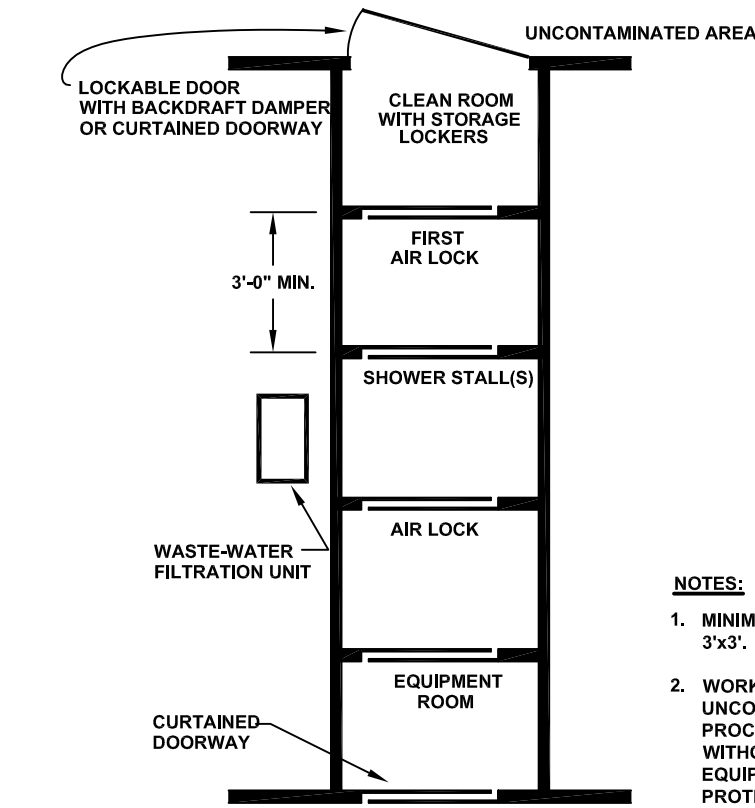

- NOTES:**
1. MINIMUM CHAMBER SIZE SHALL BE 3'x3'.
  2. WORKERS FROM THE UNCONTAMINATED AREA SHALL NOT PROCEED BEYOND THE FIRST AIR LOCK WITHOUT PROPER RESPIRATORY EQUIPMENT AND FULL-BODY PROTECTION.
  3. WORKERS EXITING FROM THE WORK AREA SHALL PROPERLY DECONTAMINATE.

**6** PERSONNEL DECONTAMINATION ENCLOSURE SYSTEM SCHEMATIC  
SCALE: N.T.S.

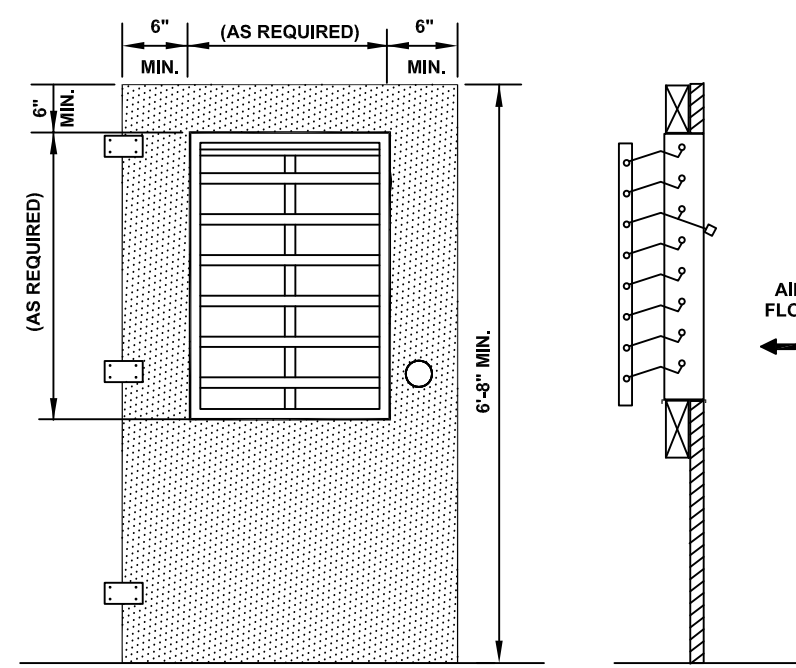

- NOTES:**
1. DOOR CONSTRUCTION SHALL BE A MINIMUM 3/4\"/>

**4** BACKDRAFT DAMPER DETAIL  
SCALE: N.T.S.

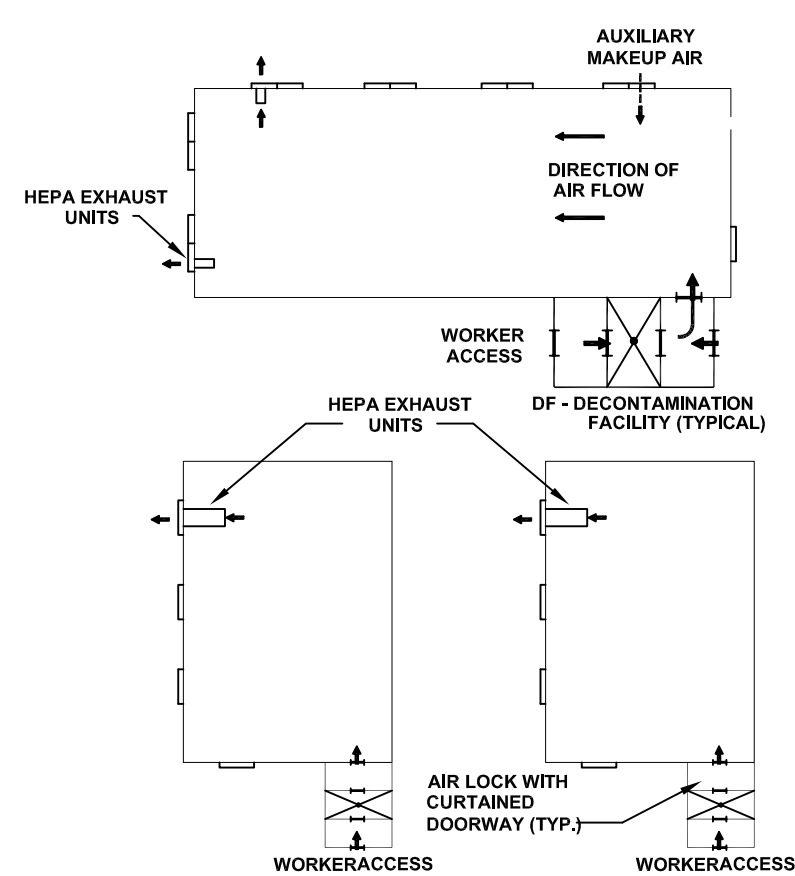

**5** HEPA EXHAUST ARRANGEMENT FOR OPTIMUM AIR AND EXCHANGE MOVEMENT  
SCALE: N.T.S.

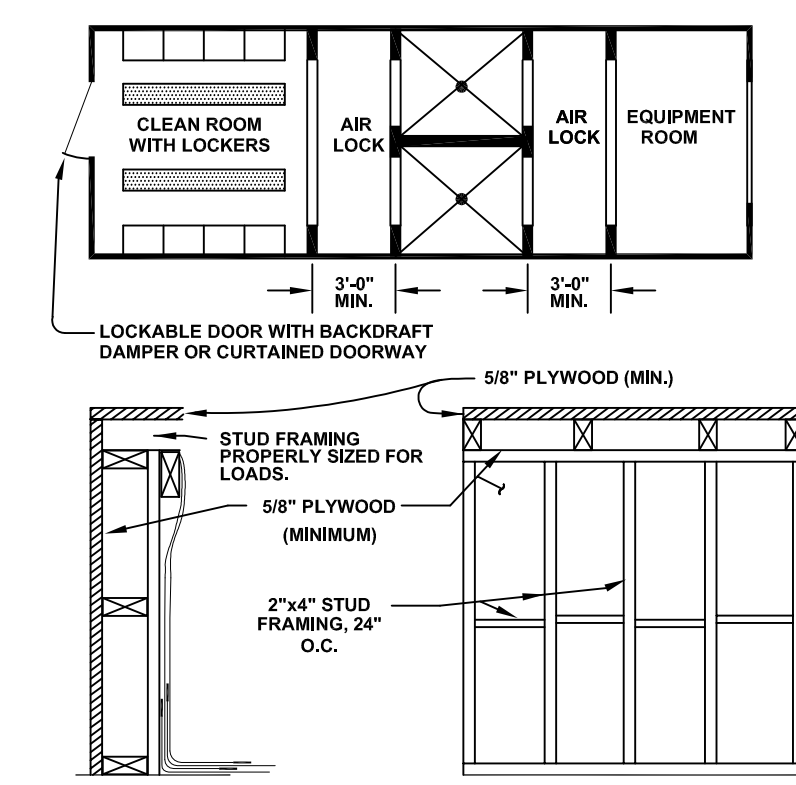

- NOTES:**
1. THE DECONTAMINATION ENCLOSURE SHALL BE CONSTRUCTED USING 2\"/>

**7** STRUCTURAL DECONTAMINATION FACILITY  
SCALE: N.T.S.

**GENERAL ENVIRONMENTAL NOTES:**

1. THE CONTRACTOR SHALL ISOLATE THE WORK AREAS, POST WARNING SIGNS, LOCKOUT AND TAG THE ELECTRICAL SYSTEM AS DESCRIBED IN SECTION 02 82 10, ESTABLISH DECONTAMINATION FACILITIES, AND PERFORM ALL PREAMBATEMENT ACTIVITIES AS DESCRIBED IN SECTIONS 02 82 10 AND 02 82 40.
2. THE CONTRACTOR SHALL PROVIDE TEMPORARY POWER AND LIGHTING EQUIPPED WITH GROUND FAULT INTERRUPTER (GFI) DEVICES TO ALL WORK AREAS AS DESCRIBED IN SECTIONS 02 82 10 AND 02 82 40. CONNECTIONS FOR TEMPORARY POWER FROM PERMANENT SERVICES ARE TO BE PERFORMED BY A QUALIFIED ELECTRICIAN. THE CONTRACTOR SHALL NOTE SHUTDOWNS AND TIENS SHALL BE SCHEDULED WITH LSU IN ADVANCE; THE CONTRACTOR SHALL COORDINATE WITH THE GENERAL CONTRACTOR PRIOR TO PERFORMING SHUTDOWNS OR TIE-INS.
3. THE CONTRACTOR SHALL ENSURE THAT ALL EMPLOYEES UTILIZE PROPER PROCEDURES FOR RESPIRATORY AND PERSONNEL PROTECTION AND DECONTAMINATION PROCEDURES AS DESCRIBED IN SECTIONS 02 82 10 AND 02 82 40.
4. THE CONTRACTOR SHALL INSTALL AND ERECT SUFFICIENT SCAFFOLDING AND/OR WORK PLATFORMS TO ACCESS ALL AREAS AND COMPLETE ALL TASKS RELATED TO THE ENVIRONMENTAL ABATEMENT AND SELECTED DEMOLITION IN A MANNER THAT ALLOWS FOR THE RENOVATION OF THE BUILDING. INSTALLATION, ERECTION AND USE OF SCAFFOLDING AND WORK PLATFORMS AND MANLIFTS SHALL BE PERFORMED IN STRICT COMPLIANCE WITH APPLICABLE FEDERAL, STATE AND LOCAL LAWS AND REGULATIONS, AS DESCRIBED IN SECTIONS 02 82 10 AND 02 82 40; INCLUDING BUT NOT LIMITED TO DAILY INSPECTIONS OF SCAFFOLDING AND WORK PLATFORMS AND SAFETY TRAINING MEETINGS AND 100% TIE-OFF FOR ALL WORKERS.
5. THE CONTRACTOR SHALL INSTALL RIGID BARRIER WALLS AND CAULK AND SEAL CONNECTIONS TO EXISTING WALLS, FLOOR, AND DECK AS REQUIRED AND AS DESCRIBED IN SECTIONS 02 82 10 AND 02 82 40. REFER TO DETAILS FOR RIGID BARRIER WALLS. THE CONTRACTOR SHALL REMOVE ALL RIGID BARRIER WALLS AFTER RECEIPT OF WRITTEN APPROVAL FROM THE ENVIRONMENTAL CONSULTANT. ALL MATERIALS USED SHALL BE FIRE RETARDANT.
6. THE CONTRACTOR SHALL PROTECT THE ELECTRICAL SYSTEM SERVICE, SERVICE CONDUITS AND PANELS, UTILITY PIPING SYSTEMS, ROOF STORM WATER, DRAINS AND PIPING SYSTEMS DURING THE ENVIRONMENTAL PHASE OF THE WORK. THE CONTRACTOR SHALL COORDINATE IN ADVANCE WITH THE GENERAL RENOVATION CONTRACTOR PRIOR TO REMOVAL OF ANY BUILDING UTILITY AND SYSTEM COMPONENT.
7. THE CONTRACTOR SHALL UTILIZE PROPER ENGINEERING CONTROLS AND CONDUCT PERSONNEL MONITORING THROUGHOUT THE ENVIRONMENTAL PHASE OF THE PROJECT IN ACCORDANCE WITH SECTION 02 82 10.
8. THE CONTRACTOR SHALL INSTALL HEPA-FILTERED EXHAUST SYSTEMS AS DESCRIBED IN SECTIONS 02 82 10 AND 02 82 40.
9. THE CONTRACTOR SHALL INSTALL AUTOMATIC AIR PRESSURE DIFFERENTIAL RECORDING INSTRUMENTS IN THE WORK AREAS AS DESCRIBED IN SECTIONS 02 82 10 AND 02 82 40. THE CONTRACTOR SHALL EXHAUST CONTAINMENT/S TO THE BUILDING EXTERIOR.
10. THE CONTRACTOR SHALL MAINTAIN EMERGENCY EXITS AS DESCRIBED IN SECTIONS 02 82 10 AND 02 82 40.
11. BEFORE COMMENCING WORK WITHIN THE WORK AREA, THE CONTRACTOR SHALL INSPECT THE WORK ENCLOSURE FOR BREACHES AND LEAKS AS DESCRIBED IN SECTIONS 02 82 10 AND 02 82 40. THE CONTRACTOR SHALL SEAL PROPERLY ANY LEAKS BEFORE BEGINNING WORK.
12. AFTER THE WORK AREAS HAVE BEEN PREPARED, THE CONTRACTOR SHALL REQUEST A FORMAL SITE INSPECTION BY THE ENVIRONMENTAL CONSULTANT AND ASSIST THE ENVIRONMENTAL CONSULTANT IN THEIR EFFORTS TO SMOKE TEST/INSPECT THE CONTAINMENT FOR LEAKS. THE CONTRACTOR SHALL NOT COMMENCE REMOVAL OR OTHER DISTURBANCE OF ASBESTOS-CONTAINING MATERIALS, UNTIL THE ENVIRONMENTAL CONSULTANT HAS INSPECTED AND APPROVED THE SITE PREPARATION WORK.
13. THE CONTRACTOR SHALL SCHEDULE WASTE DISPOSAL IN ADVANCE WITH THE GENERAL RENOVATION CONTRACTOR.
14. THE CONTRACTOR SHALL ENSURE THAT ALL BUILDING COMPONENTS AND EQUIPMENT SCHEDULED TO REMAIN FOR THE BUILDING RENOVATION AND/OR SALVAGE AND FOR THE PROTECTION OF THE BUILDING IS CLEANED OF ALL ASBESTOS MATERIALS AND PROTECTED DURING THE ENVIRONMENTAL REMOVAL PHASE.
15. THE CONTRACTOR SHALL CLEAN (AS NECESSARY) THE MECHANICAL AND ELECTRICAL EQUIPMENT, WALLS, CEILINGS AND FIXED FURNITURE AND CABINETS (WITHIN THE WORK AREAS) TO OBTAIN ACCESS TO THE ASBESTOS-CONTAINING MATERIALS. IF AN ITEM CANNOT BE PROPERLY CLEANED, THE CONTRACTOR SHALL DISPOSE OF IT AS AN ASBESTOS-CONTAMINATED MATERIAL. THE MECHANICAL AND ELECTRICAL EQUIPMENT WHICH IS CLEANED BY THE CONTRACTOR SHALL BE INSPECTED VISUALLY BY THE ENVIRONMENTAL CONSULTANT BEFORE THE CONTRACTOR IS PERMITTED TO REMOVE IT FROM THE WORK AREA. THE CONTRACTOR SHALL COORDINATE WITH THE GENERAL RENOVATION CONTRACTOR PRIOR TO REMOVAL OF ANY BUILDING COMPONENT.
16. THE CONTRACTOR SHALL SEAL ALL OPENINGS THROUGH WALLS, SLAB/DECK AND ROOF THAT EXIST OR WILL BE CREATED BY THE REMOVAL PROCESS TO PROTECT THE BUILDING AND THE SAFETY OF WORKERS AND THE INTEGRITY OF THE CONTAINMENT.
17. THE CONTRACTOR SHALL FIELD VERIFY THE QUANTITY OF ASBESTOS-CONTAINING MATERIALS TO BE REMOVED AND DISPOSED OF, THE QUANTITY OF MECHANICAL AND ELECTRICAL EQUIPMENT AND PIPING TO BE CLEANED AND DISPOSED OF AND QUANTITY OF WALLS, FLOORS, AND MOVEABLE OBJECTS TO BE REMOVED AND DISPOSED OF. THE CONTRACTOR SHALL COORDINATE WITH THE GENERAL RENOVATION CONTRACTOR PRIOR TO REMOVAL OF ANY BUILDING COMPONENT, EQUIPMENT OR CONTENTS. SALVAGE MATERIALS WHEREVER POSSIBLE. OWNER HAS FIRST RIGHT OF REFUSAL.
18. THE CONTRACTOR SHALL COMPLETE ALL SELECTED DEMOLITION WORK OF WALLS, CEILINGS, CHASES AND SURROUNDS FOR ACCESS AND FOR REMOVAL OF THE ASBESTOS-CONTAINING AND CONTAMINATED MATERIALS IN A MANNER THAT PERMITS RENOVATION TO THE BUILDING, COMPLETE REMOVAL AND THE FULL INSPECTION OF THE WORK.
19. THE CONTRACTOR SHALL NOTE: THE SCOPE OF WORK AND WORK ITEMS INCLUDED WITHIN THESE GENERAL NOTES AND THE SHEET NOTES ARE A PART OF THE SCOPE OF WORK FOR THIS PROJECT AND ALL WORK SHALL BE PERFORMED USING WORKMANSHIP-LIKE METHODS.
20. FINAL AIR TESTING SHALL BE PERFORMED PURSUANT TO THE UNITED STATES ENVIRONMENTAL PROTECTION AGENCY 40 CFR PART 763 (APPENDIX A) USING TRANSMISSION ELECTRON MICROSCOPY (TEM), AGGRESSIVE DISTURBANCE PROCEDURES, CONTINUOUS AIR CIRCULATION, AND HEPA-FILTERED EXHAUST.
21. THE CONTRACTOR SHALL MAINTAIN PROPER FEDERAL AND STATE LICENSING TO CONDUCT HAZARDOUS MATERIAL REMOVAL AND DISPOSAL AS DESCRIBED WITHIN THESE DOCUMENTS.



ASBESTOS ABATEMENT DESIGNER  
*Harry Rayner* 8/31/23  
HARRY RAYNER DATE  
CERTIFICATE NO. AD114892

These drawings are the property of DOMAIN ARCHITECTURE APAC and are not to be reproduced in whole or in part. They are only to be used for the project and site specifically identified herein. Scales stated herein are valid on the original drawings only. Contractor shall carefully review all dimensions and conditions shown and report to the architect any errors, inconsistencies, or omissions discovered. These plans were prepared in this office under our personal supervision, and to the best of our knowledge comply with state and local codes. We will generally administer construction.

Southern University Laboratory School  
**RESTROOM RENOVATIONS**

129 SWAN STREET,  
BATON ROUGE, LA 70813

ENVIRONMENTAL ENGINEER  
RAYNER CONSULTING GROUP, LLC  
7353 HIGHLAND RD., SUITE B-58  
BATON ROUGE, LA 70808  
225.916.2824  
MECHANICAL ENGINEER  
ADG BATON ROUGE, LLC  
5071 TEDDY DRIVE  
BATON ROUGE, LA 70809  
225.293.9474

revisions		
No.	Description	Date

date: August 31, 2023  
director review: HR

AUGUST 31, 2023

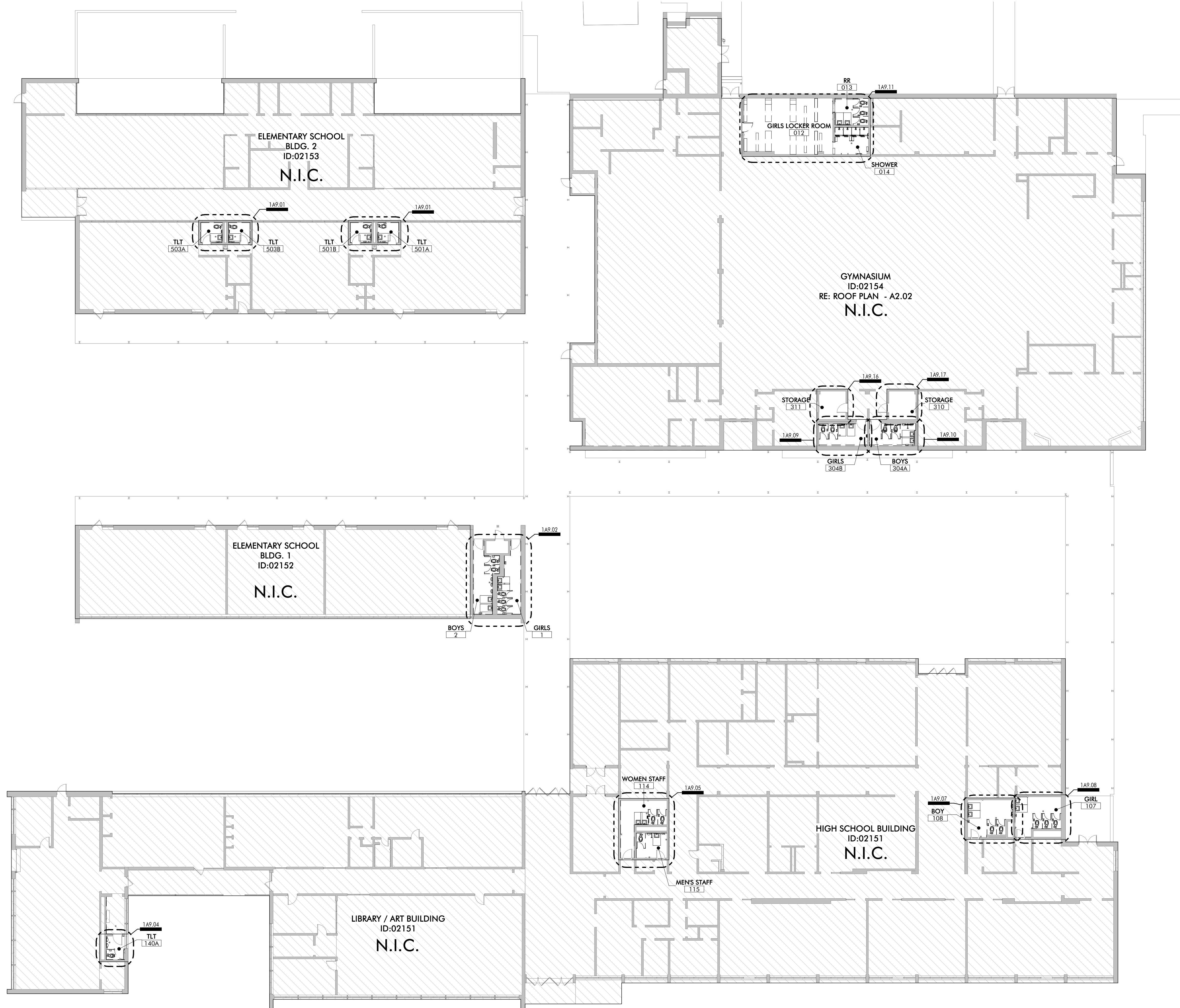

**1** 1ST FLOOR - DEMOLITION FLOOR PLAN  
1/16" = 1'-0" DRAWN BY: KAS

ARCHITECT

**DOMAIN**  
ARCHITECTURE  
APAC

8316 kelwood avenue, baton rouge, la 70806  
t: 225.216.3770 f: 225.216.3771  
www.domain-arch.com

REGISTRATION

These drawings are the property of DOMAIN ARCHITECTURE APAC and are not to be reproduced in whole or in part. They are only to be used for the project and site specifically identified herein. Scales stated hereon are valid on the original drawings only. Contractor shall carefully review all dimensions and conditions shown and report to the architect any errors, inconsistencies, or omissions discovered. These plans were prepared in the office under our personal supervision, and to the best of our knowledge comply with state and local codes. We will generally administer construction.

CLIENT

Southern University Laboratory School  
**RESTROOM RENOVATIONS**

129 SWAN AVE,  
BATON ROUGE, LA 70813

PROJECT INFORMATION

revisions	No.	Description	Date

project # C22-0072  
date AUGUST 31, 2023  
director review

1ST FLOOR - DEMO  
FLOOR PLAN

**D2.01**



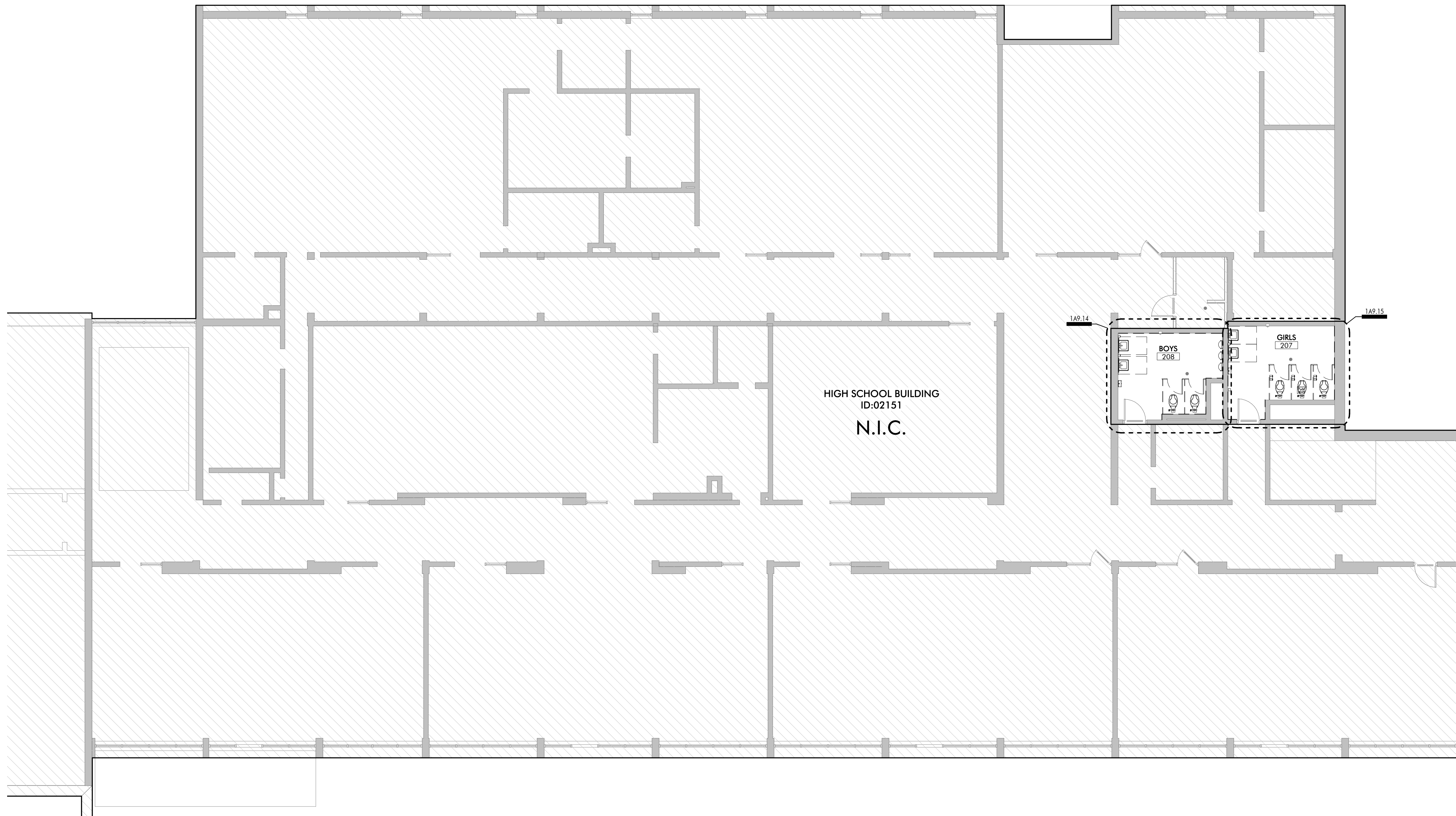

**1** 2ND FLOOR - DEMOLITION FLOOR PLAN  
 1/8" = 1'-0" DRAWN BY: KAS

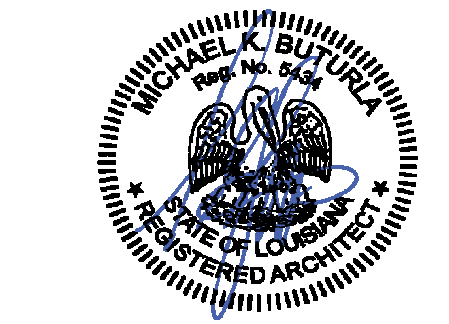

These drawings are the property of DOMAIN ARCHITECTURE APAC and are not to be reproduced in whole or in part. They are only to be used for the project and site specifically identified herein. Scales stated hereon are valid on the original drawings only. Contractor shall carefully review all dimensions and conditions shown and report to the architect any errors, inconsistencies, or omissions discovered. These plans were prepared in the office under our personal supervision, and to the best of our knowledge comply with state and local codes. We will generally administer construction.

Southern University Laboratory School  
**RESTROOM RENOVATIONS**

129 SWAN AVE,  
 BATON ROUGE, LA 70813

revisions	No.	Description	Date

project # C22-0072

date AUGUST 31, 2023

director review

2ND FLOOR - DEMO FLOOR PLAN

**D2.02**



These drawings are the property of DOMAIN ARCHITECTURE APAC and are not to be reproduced in whole or in part. They are only to be used for the project and site specifically identified herein. Scales stated herein are valid on the original drawings only. Contractor shall carefully review all dimensions and conditions shown and report to the architect any errors, inconsistencies, or omissions discovered. These plans were prepared in the office under our personal supervision, and to the best of our knowledge comply with state and local codes. We will generally administer construction.

CLIENT

Southern University Laboratory School  
**RESTROOM RENOVATIONS**  
129 SWAN AVE,  
BATON ROUGE, LA 70813

revisions	No.	Description	Date

project # C22-0072  
date AUGUST 31, 2023  
director review

1ST FLOOR - DEMO RCP

**D5.01**

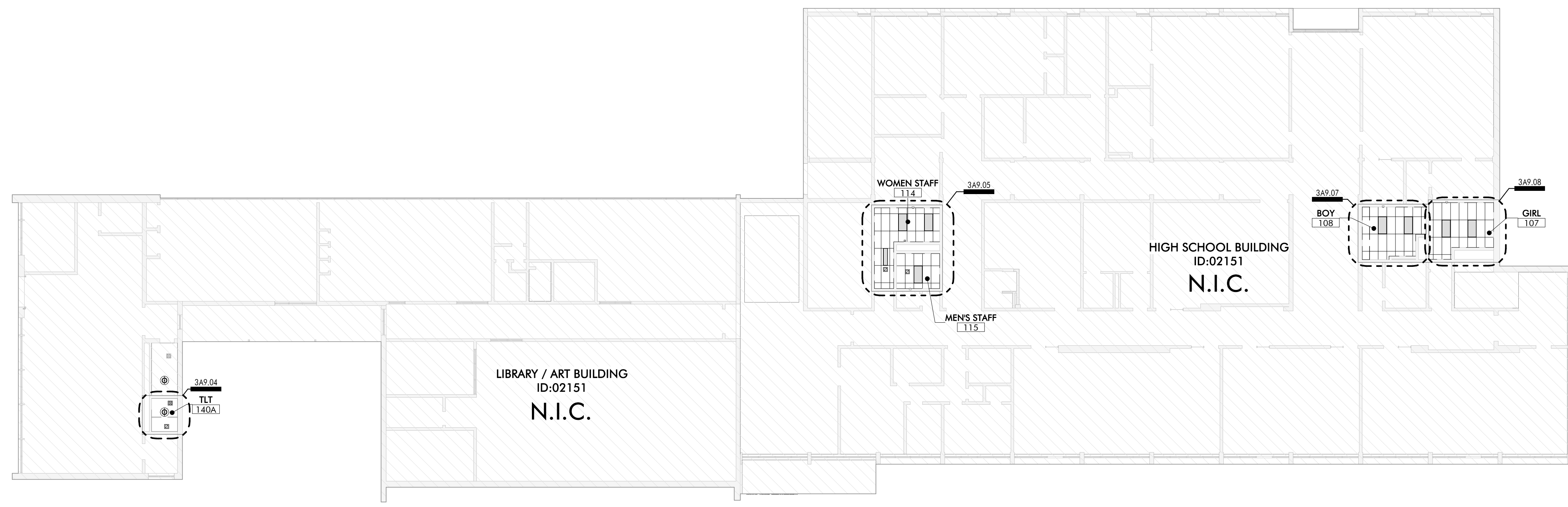
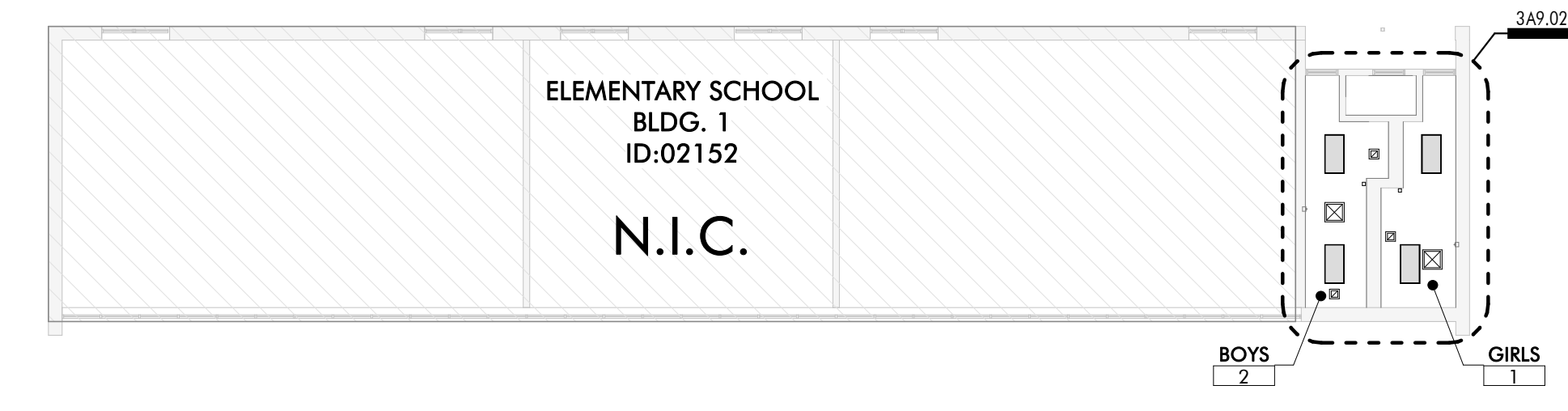
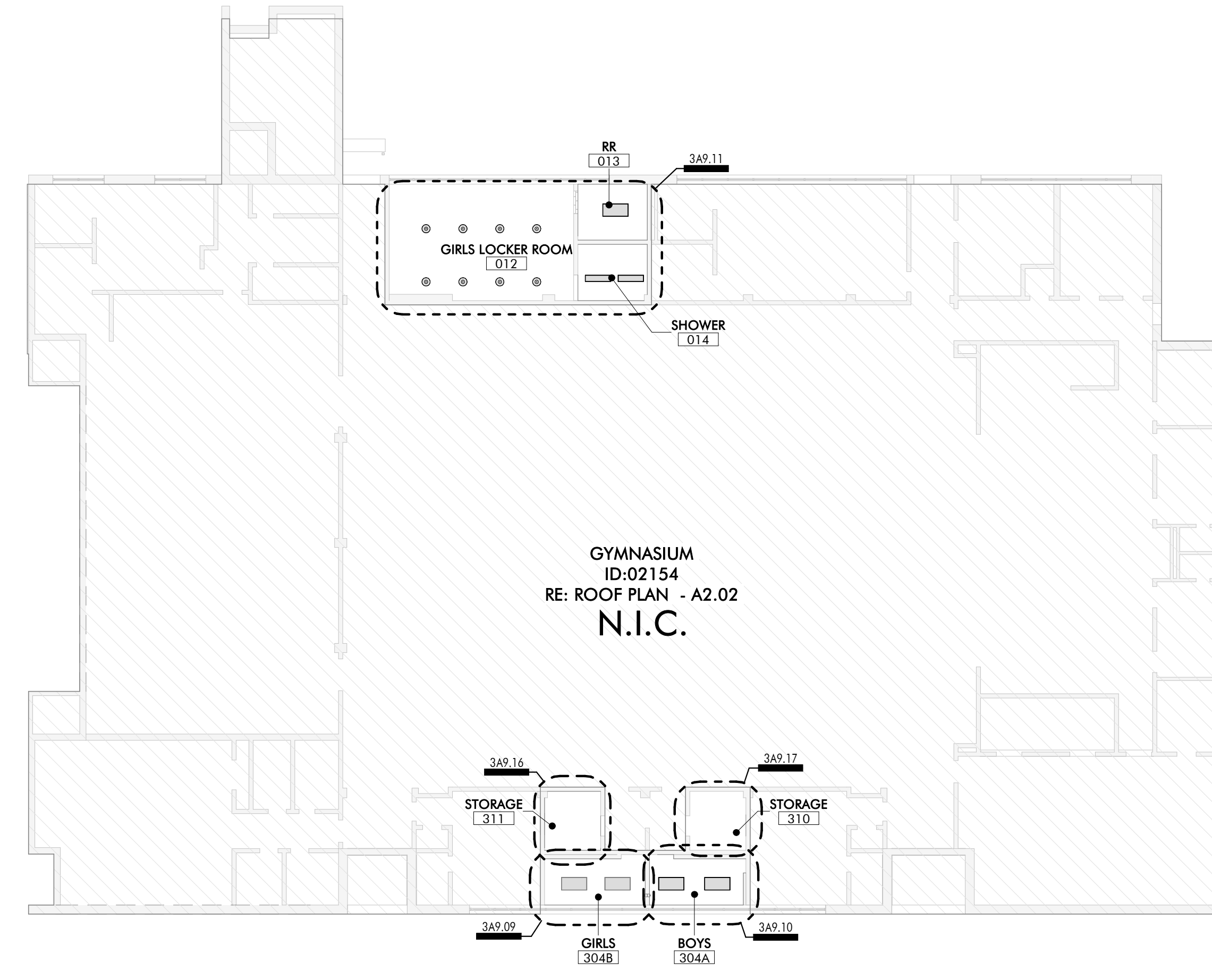
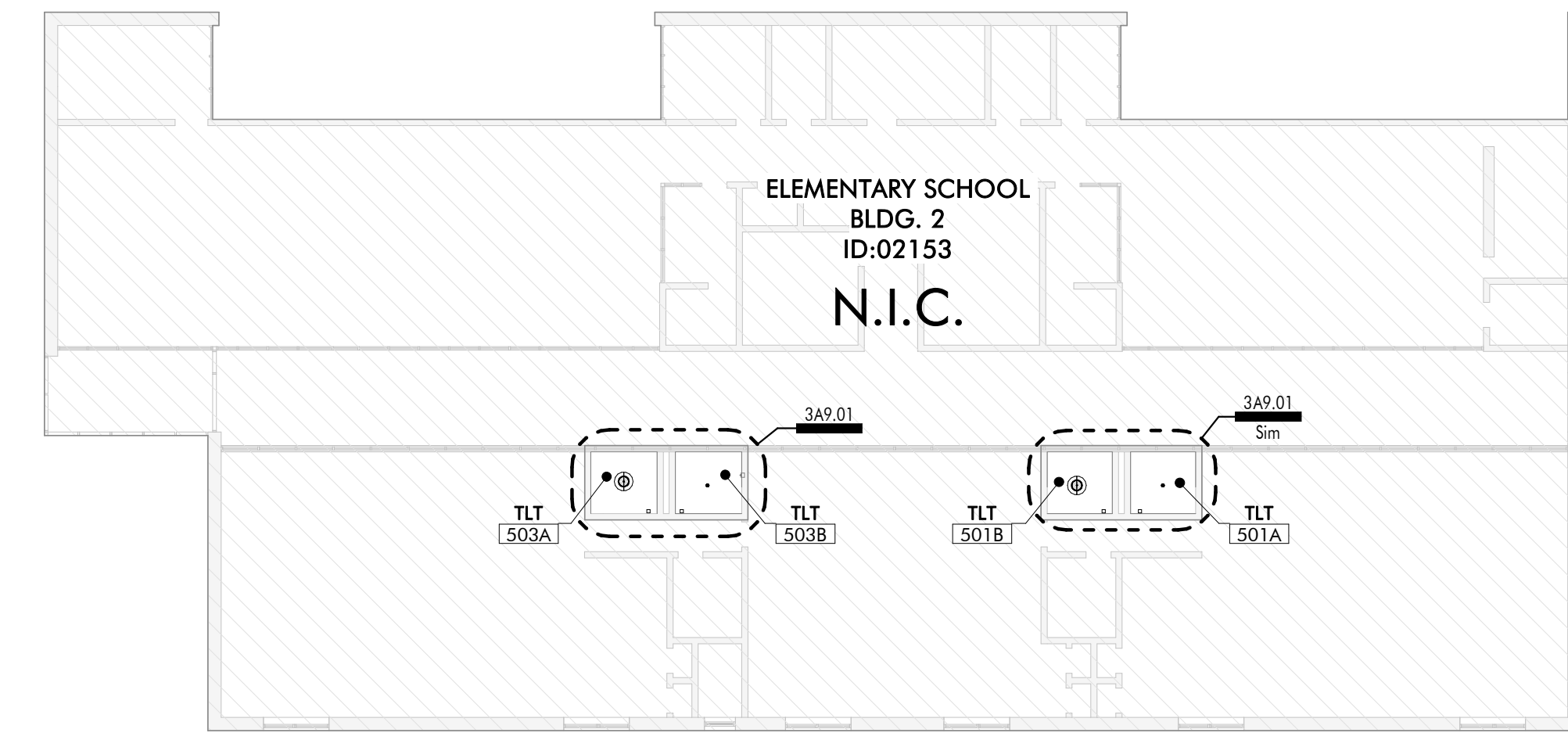

**1** 1ST FLOOR - DEMOLITION REFLECTED CEILING PLAN  
1/16" = 1'-0" DRAWN BY: KAS

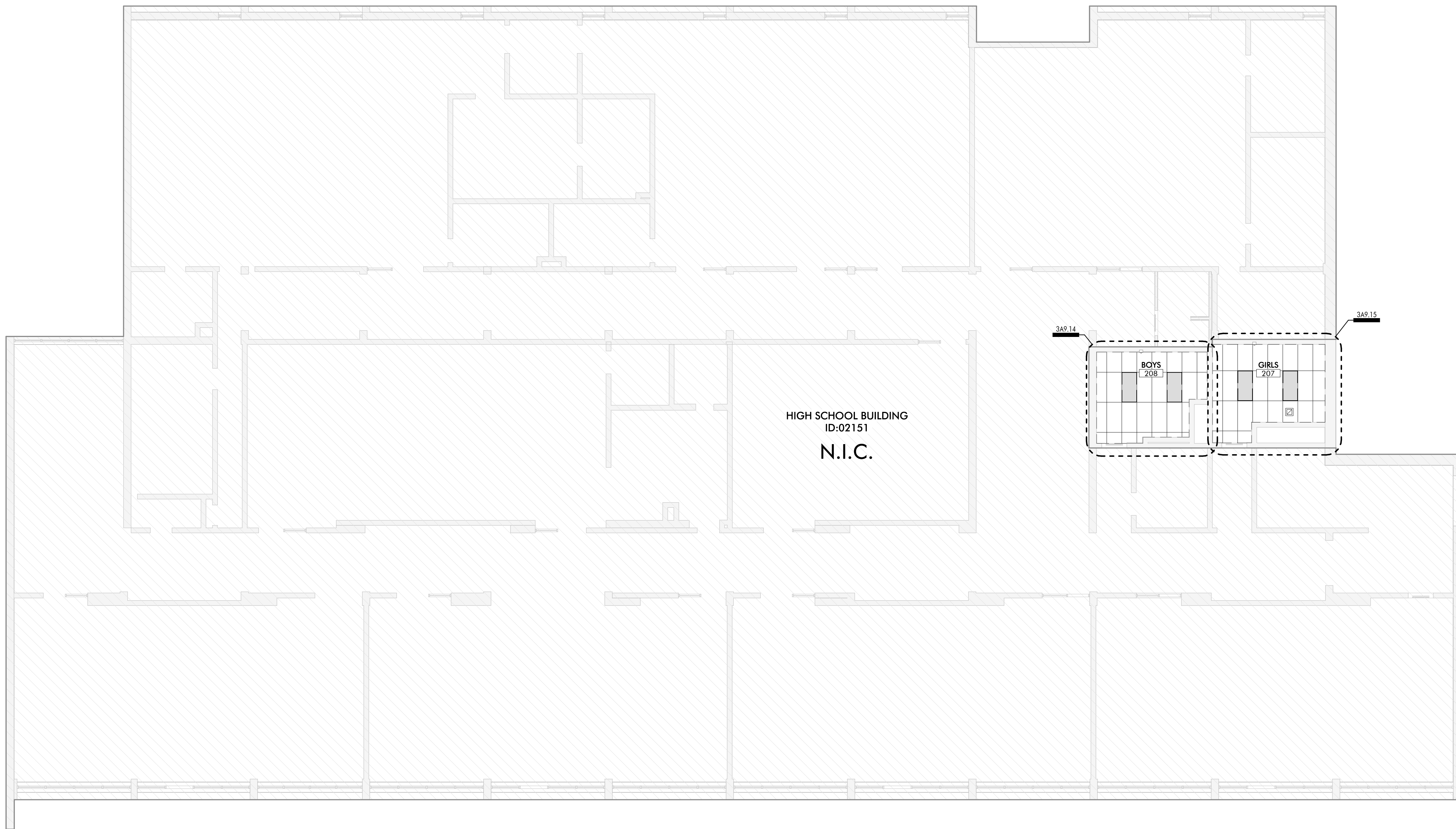

1

2ND FLOOR - DEMOLITION REFLECTED CEILING PLAN

1/8" = 1'-0" DRAWN BY: KAS

ARCHITECT



8316 kelwood avenue  
baton rouge, la 70806  
t: 225.216.3770 f: 225.216.3771  
www.domain-arch.com

REGISTRATION



These drawings are the property of DOMAIN ARCHITECTURE APAC and are not to be reproduced in whole or in part. They are only to be used for the project and site specifically identified herein. Scales stated herein are valid on the original drawings only. Contractor shall carefully review all dimensions and conditions shown and report to the architect any errors, inconsistencies, or omissions discovered. These plans were prepared in the office under our personal supervision, and to the best of our knowledge comply with state and local codes. We will generally administer construction.

CLIENT

Southern University Laboratory School  
**RESTROOM RENOVATIONS**

129 SWAN AVE,  
BATON ROUGE, LA 70813

PROJECT INFORMATION

revisions No.	Description	Date

project # C22-0072

date AUGUST 31, 2023

director review

2ND FLOOR - DEMO  
RCP

D5.02



GENERAL NOTES	
MARK	DESCRIPTION
A	MAIN STAGING AREA FOR CONTRACTOR
B	SUB-STAGING / PARKING AREA
C	STAGING AREAS SHALL BE REGRADED AND SEEDED WHEN THE CONSTRUCTION PROJECT HAS BEEN COMPLETED.
D	STAGING AREAS MUST BE FENCED AND LOCKABLE AT ALL TIMES.
E	CONTRACTOR MUST MAINTAIN A ROUTE FOR FOOD DELIVERIES FOR THE DURATION OF CONSTRUCTION WHILE SCHOOL IS OPEN.

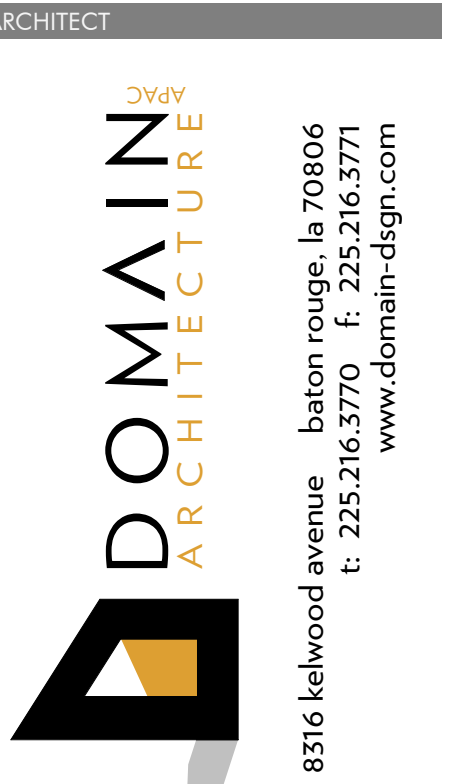

These drawings are the property of DOMAIN ARCHITECTURE APAC and are not to be reproduced in whole or in part. They are only to be used for the project and site specifically identified herein. Scales stated herein are valid on the original drawing only. Contractor shall carefully review all dimensions and conditions shown and report to the architect any errors, inconsistencies, or omissions discovered. These plans were prepared in the office under our personal supervision, and to the best of our knowledge comply with state and local codes. We will generally administer construction.

CLIENT

Southern University Laboratory School  
**RESTROOM RENOVATIONS**  
 129 SWAN AVE,  
 BATON ROUGE, LA 70813

PROJECT INFORMATION		
revisions	No.	Description

project # C22-0072  
 date AUGUST 31, 2023  
 director review

SITE PLAN - AERIAL VIEW

**A1.01**

AUGUST 31, 2023

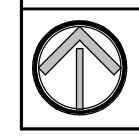

1

SITE PLAN - AERIAL VIEW  
 3/16" = 1'-0" DRAWN BY:

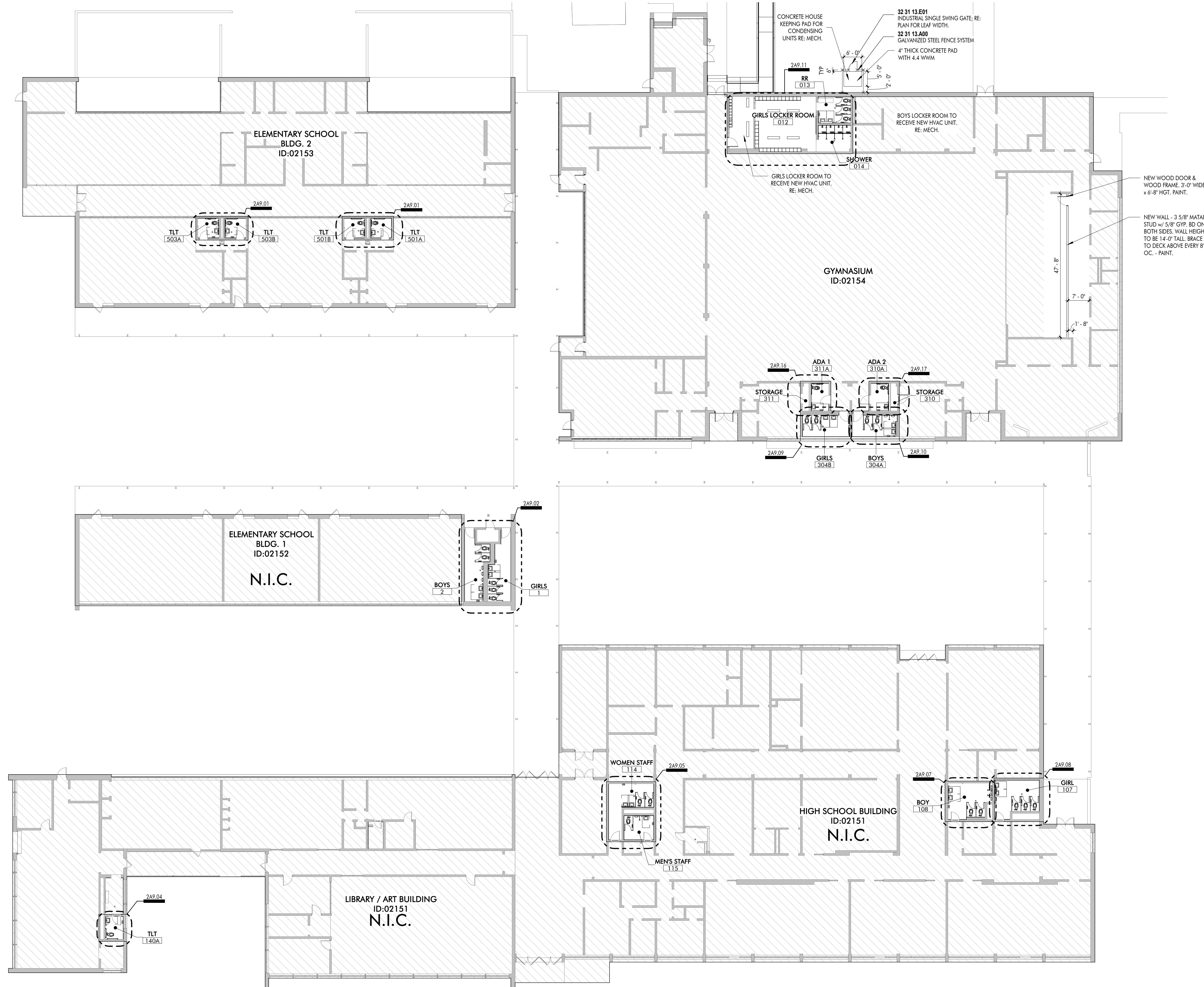

Southern University Laboratory School  
**RESTROOM RENOVATIONS**  
 129 SWAN AVE,  
 BATON ROUGE, LA 70813

revisions No.	Description	Date

project # C22-0072  
 date AUGUST 31, 2023  
 director review

1ST FLOOR NEW CONSTRUCTION  
**A2.01**

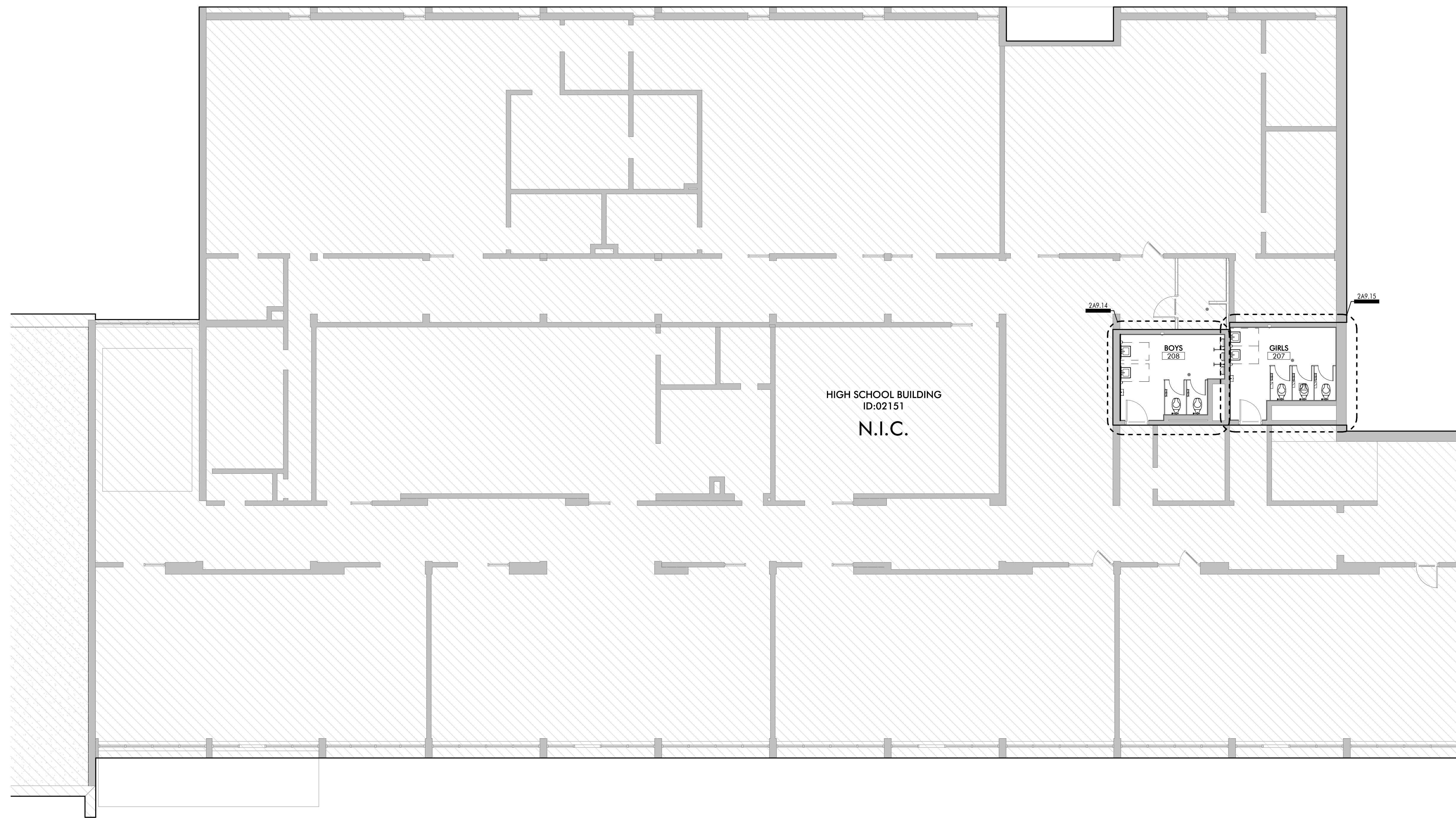

**1** 2ND FLOOR - NEW CONSTRUCTION FLOOR PLAN  
 1/8" = 1'-0" DRAWN BY: KAS

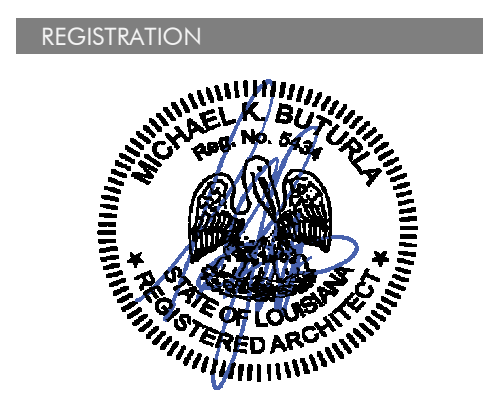

These drawings are the property of DOMAIN ARCHITECTURE APAC and are not to be reproduced in whole or in part. They are only to be used for the project and site specifically identified herein. Scales stated hereon are valid on the original drawing only. Contractor shall carefully review all dimensions and conditions shown and report to the architect any errors, inconsistencies, or omissions discovered. These plans were prepared in the office under our personal supervision, and to the best of our knowledge comply with state and local codes. We will generally administer construction.

CLIENT

Southern University Laboratory School  
**RESTROOM RENOVATIONS**  
 129 SWAN AVE,  
 BATON ROUGE, LA 70813

PROJECT INFORMATION

revisions No.	Description	Date

project # C22-0072

date AUGUST 31, 2023

director review

2ND FLOOR NEW CONSTRUCTION



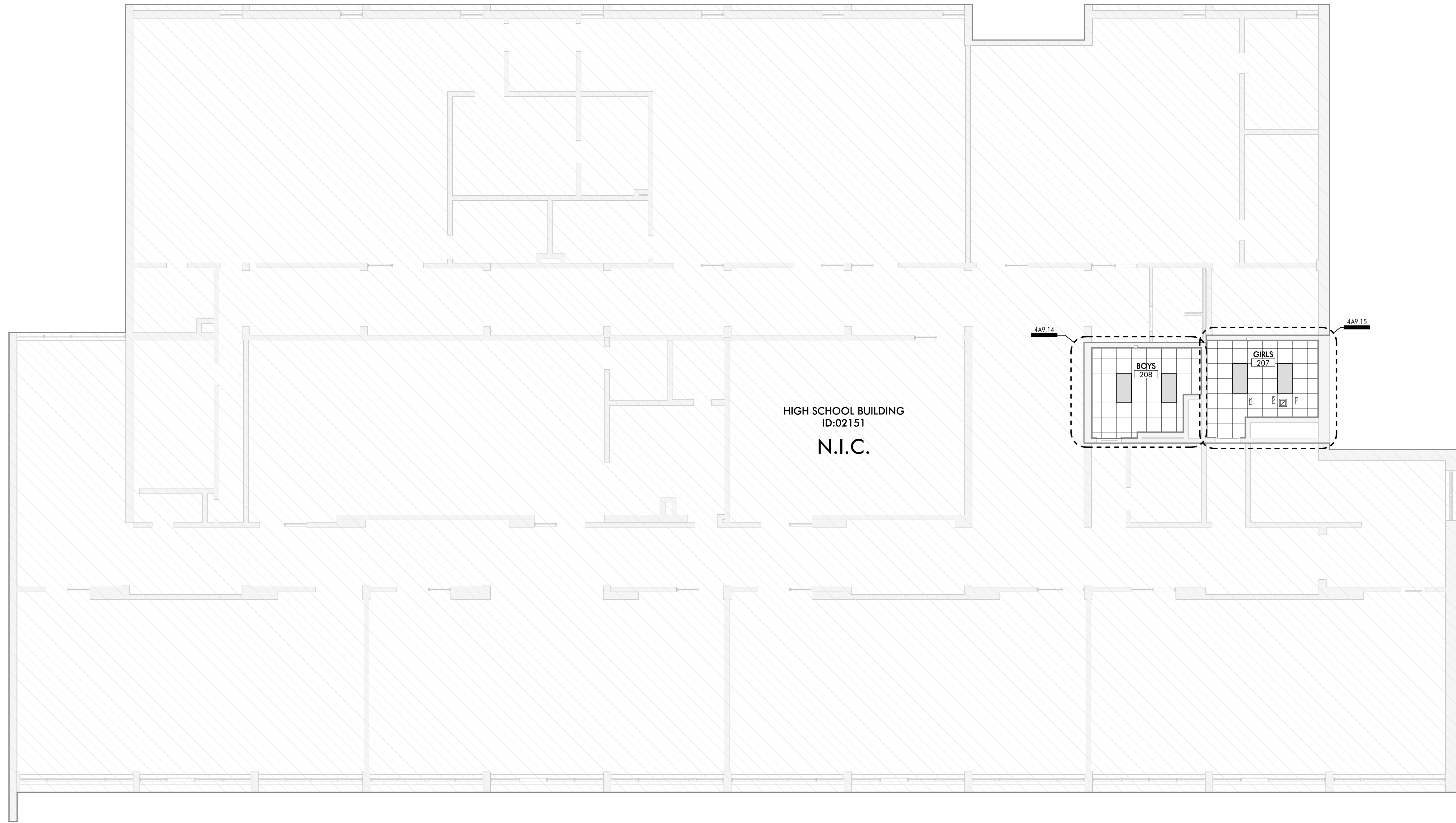

1

2ND FLOOR RCP - NEW CONSTRUCTION  
1/8" = 1'-0" DRAWN BY: KAS

ARCHITECT



8316 kelwood avenue, baton rouge, la 70806  
 t: 225.216.3770 f: 225.216.3771  
 www.domain-arch.com

REGISTRATION



These drawings are the property of DOMAIN ARCHITECTURE APAC and are not to be reproduced in whole or in part. They are only to be used for the project and site specifically identified herein. Scales stated hereon are valid on the original drawings only. Contractor shall carefully review all dimensions and conditions shown and report to the architect any errors, inconsistencies, or omissions discovered. These plans were prepared in the office under our personal supervision, and to the best of our knowledge comply with state and local codes. We will generally administer construction.

CLIENT

Southern University Laboratory School  
**RESTROOM RENOVATIONS**

129 SWAN AVE,  
 BATON ROUGE, LA 70813

PROJECT INFORMATION

revisions	No.	Description	Date

project # C22-0072

date AUGUST 31, 2023

director review

2ND FLOOR RCP

A5.02



FINISH SCHEDULE										
ROOM NUMBER	ROOM NAME	FLOOR FINISH	BASE FINISH	WALL FINISH				CEILING FINISH	COMMENTS	
				NORTH	EAST	SOUTH	WEST			
1	GIRLS	CT-1		PT-3, CT-2, CT-3	PT-3, CT-2, CT-3	PT-4, CT-2, CT-3	PT-4, CT-2, CT-3	PT-1		
2	BOYS	CT-1		PT-3, CT-2, CT-4	PT-3, CT-2, CT-4	PT-4, CT-2, CT-4	PT-3, CT-2, CT-4	PT-1		
012	GIRLS LOCKER ROOM	CT-1		PT-3, PT-4	PT-3	PT-3	PT-3	PT-1		
013	RR	CT-1		PT-4, CT-2, CT-3	CT-2, CT-3	CT-2, CT-3	CT-2, CT-3	PT-1		
014	SHOWER	CT-1		PT-3, CT-2, CT-3	PT-3, CT-2, CT-3	PT-3, CT-2, CT-3	PT-3, CT-2, CT-3	PT-1		
107	GIRL	CT-1		PT-3, CT-2, CT-3	PT-3, CT-2, CT-3	PT-3, CT-2, CT-3	PT-3, CT-2, CT-3	ACT-1		
108	BOY	CT-1		PT-3, CT-2, CT-4	PT-3, CT-2, CT-4	PT-3, CT-2, CT-4	PT-3, CT-2, CT-4	ACT-1		
114	WOMEN STAFF	CT-1		PT-3, CT-2, CT-3	PT-3, CT-2, CT-3	PT-3, CT-2, CT-3	PT-3, CT-2, CT-3	ACT-1		
115	MEN'S STAFF	CT-1		PT-3, CT-2, CT-4	PT-3, CT-2, CT-4	PT-3, CT-2, CT-4	PT-3, CT-2, CT-4	ACT-1		
140A	TLT	CT-1		PT-3, CT-2, CT-3	PT-3, PT-4, CT-2, CT-3	PT-3, CT-2, CT-3	PT-3, CT-2, CT-3	PT-1		
207	GIRLS	CT-1		PT-3, CT-2, CT-3	PT-3, CT-2, CT-3	PT-3, CT-2, CT-3	PT-3, CT-2, CT-3	ACT-1		
208	BOYS	CT-1		PT-3, CT-2, CT-4	PT-3, CT-2, CT-4	PT-3, CT-2, CT-4	PT-3, CT-2, CT-4	ACT-1		
304A	BOYS	CT-1		PT-3, CT-2, CT-4	PT-3, CT-2, CT-4	PT-4, CT-2, CT-4	PT-3, CT-2, CT-4	PT-1		
304B	GIRLS	CT-1		PT-3, CT-2, CT-3	PT-3, CT-2, CT-3	PT-4, CT-2, CT-3	PT-3, CT-2, CT-3	PT-1		
310	STORAGE	CT-1	RB-1	PT-3	PT-3	PT-3	PT-3	PT-1		
310A	ADA 2	CT-1		PT-3, CT-2, CT-3	PT-3, CT-2, CT-3	PT-3, CT-2, CT-3	PT-3, CT-2, CT-3	PT-1		
311	STORAGE	CT-1	RB-1	PT-3	PT-3	PT-3	PT-3	PT-1		
311A	ADA 1	CT-1		PT-3, CT-2, CT-3	PT-3, CT-2, CT-3	PT-3, CT-2, CT-3	PT-3, CT-2, CT-3	PT-1		
501A	TLT	CT-1		PT-4, CT-2, CT-4	PT-3, CT-2, CT-4	PT-3, CT-2, CT-4	PT-3, CT-2, CT-4	PT-1		
501B	TLT	CT-1		PT-4, CT-2, CT-4	PT-3, CT-2, CT-4	PT-3, CT-2, CT-4	PT-3, CT-2, CT-4	PT-1		
503A	TLT	CT-1		PT-4, CT-2, CT-4	PT-3, CT-2, CT-4	PT-3, CT-2, CT-4	PT-3, CT-2, CT-4	PT-1		
503B	TLT	CT-1		PT-4, CT-2, CT-4	PT-3, CT-2, CT-4	PT-3, CT-2, CT-4	PT-3, CT-2, CT-4	PT-1		

FINISH LEGEND					
FINISH MARK	MANUFACTURER	DESCRIPTION	SIZE	MODEL, NAME, & COLOR	COMMENTS
<b>BASE</b>					
RB-1	FLEXICO	RUBBER BASE	4" COVE	093 GRAPHITE	
<b>CEILING</b>					
ACT-1	ARMSTRONG	ACOUSTICAL CEILING TILE	24" x 24" x 3/4"	CLEAN ROOM VL #868	
<b>CONCRETE</b>					
SC-1					
<b>PAINT</b>					
PT-1	SHERWIN WILLIAMS	PAINT		7007 CEILING BRIGHT WHITE	CEILING
PT-2	SHERWIN WILLIAMS	PAINT		SW 7068 GRIZZLE GRAY	DOOR AND TRIM
PT-3	SHERWIN WILLIAMS	PAINT		7065 ARGOS	TYPICAL WALL PAINT
PT-4	SHERWIN WILLIAMS	PAINT		7067 CITYSCAPE	STOREFRONT PAINT
<b>TILES</b>					
CT-1	ATLAS CONCORDE	CERAMIC TILE	12 X 24	FRAY - SMOKE	
CT-2	DALTILE	CERAMIC TILE	4" x 16"	COLOR WHEEL LINEAR - 0190 ARCTIC WHITE	INSTALL RUNNING BOND
CT-3	DALTILE	CERAMIC TILE	4" x 16"	COLOR WHEEL LINEAR - 1012 MUSTARD	INSTALL RUNNING BOND
CT-4	DALTILE	CERAMIC TILE	4" x 16"	COLOR WHEEL LINEAR - 0115 EMERALD	INSTALL RUNNING BOND
<b>TOILET PARTITION</b>					
TP-1	SCRANTON PRODUCTS	TOILET PARTITION		HINEY HIDERS - GREY	ORANGE PEEL TEXTURE

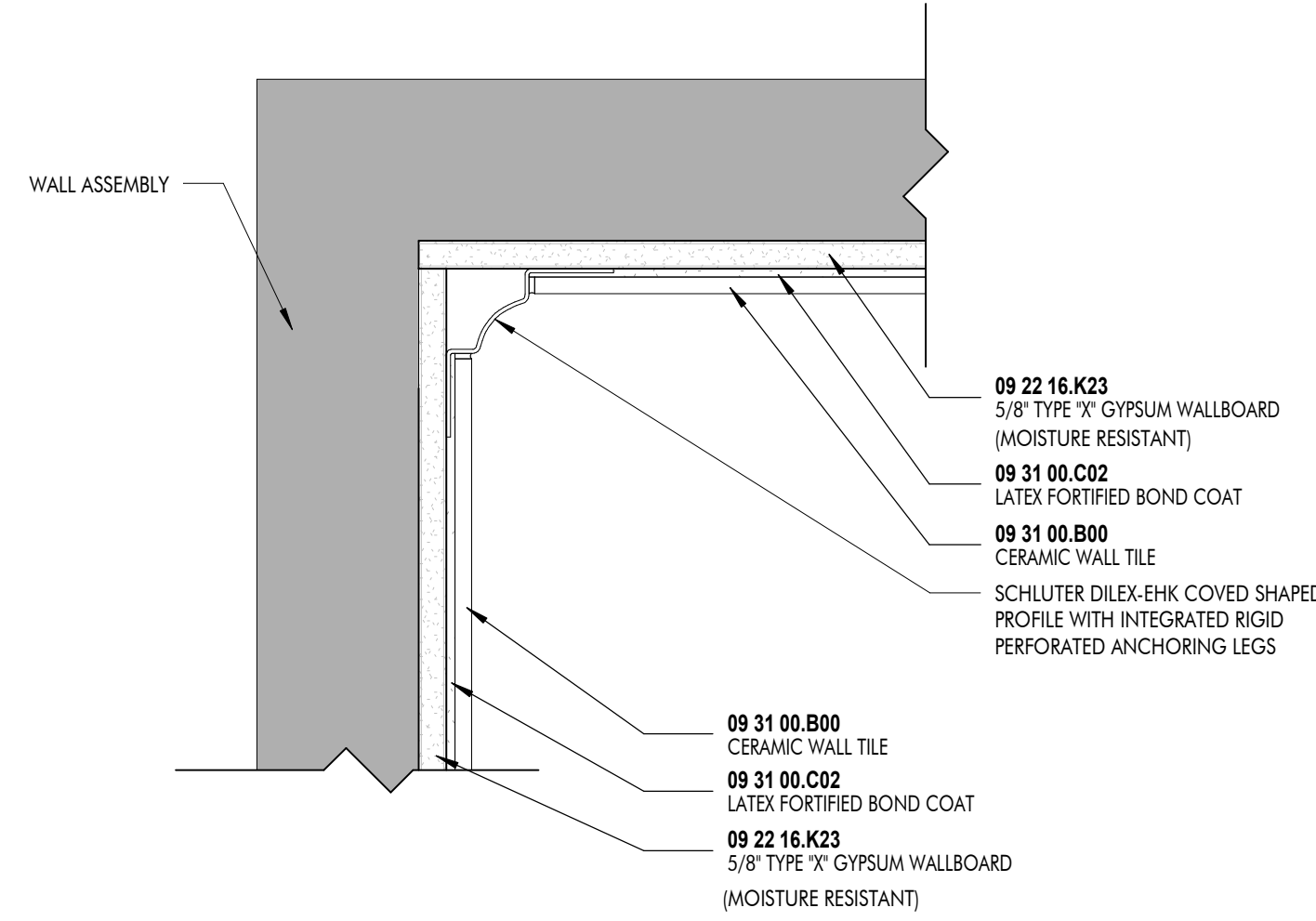

**1 CERAMIC WALL TILE - INSIDE CORNER**  
3" = 1'-0" DRAWN BY: KAS

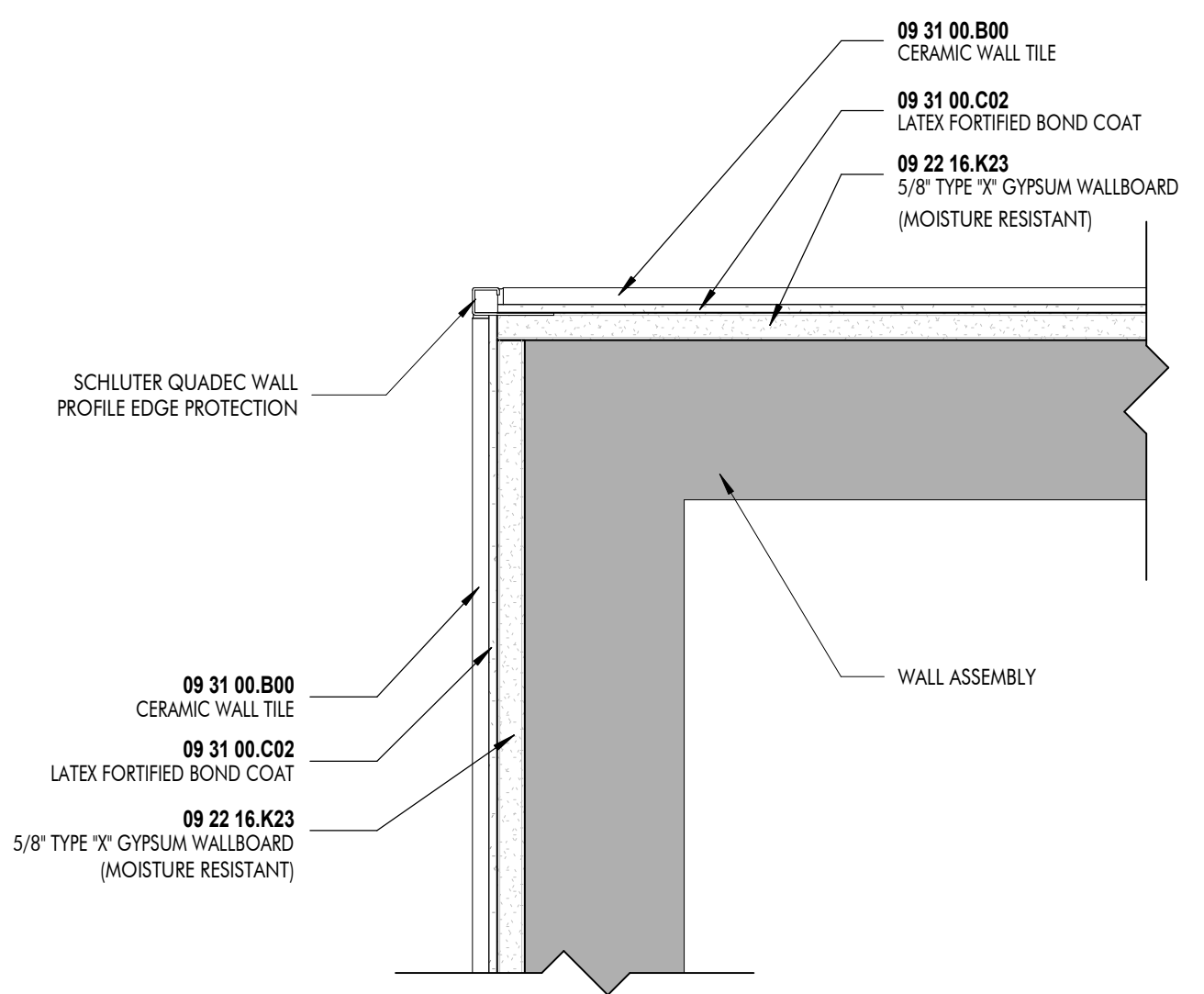

**2 CERAMIC WALL TILE - OUTSIDE CORNER**  
3" = 1'-0" DRAWN BY: KAS

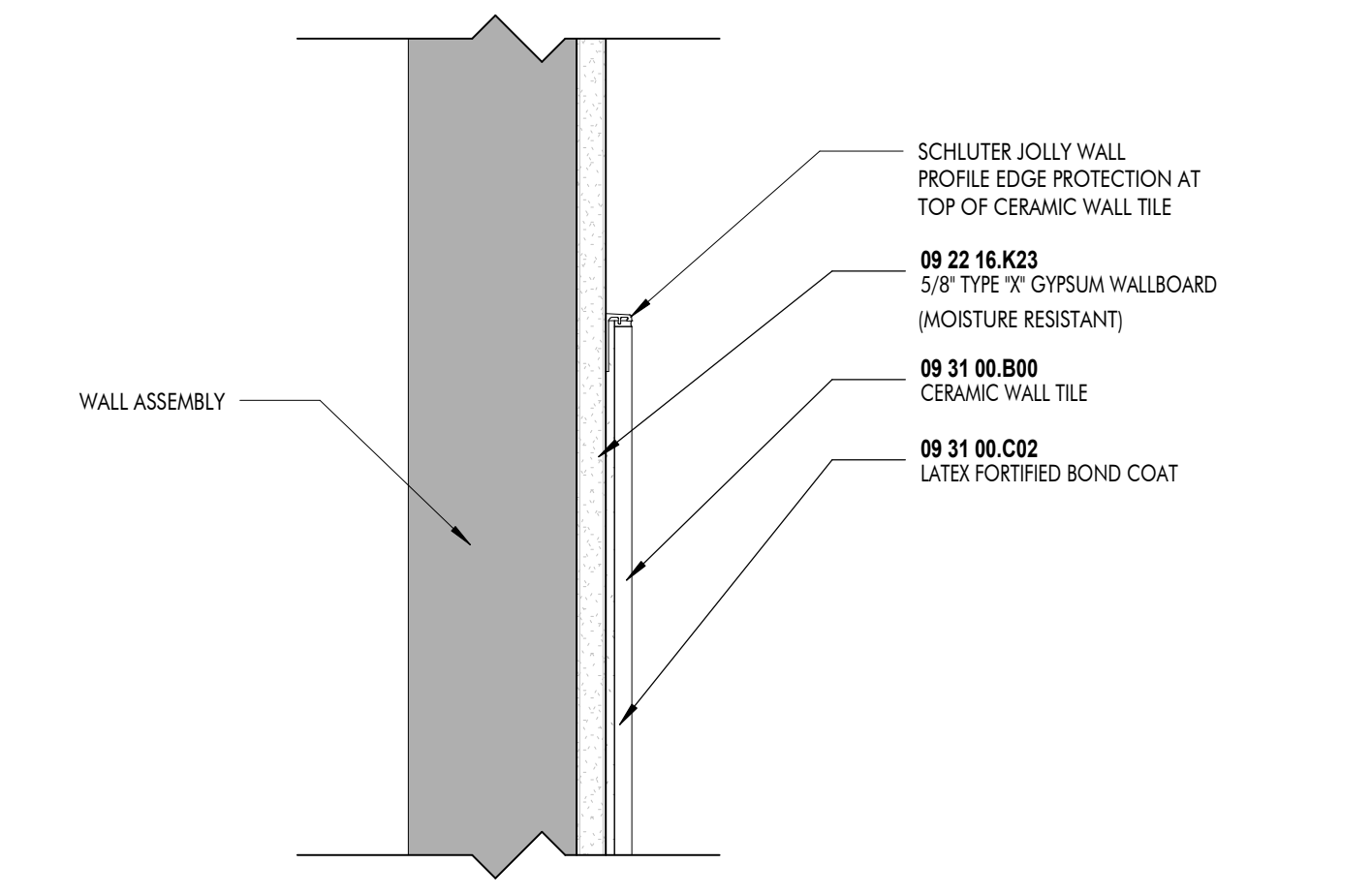

**3 CERAMIC WALL TILE - WALL TERMINATION**  
3" = 1'-0" DRAWN BY: KAS

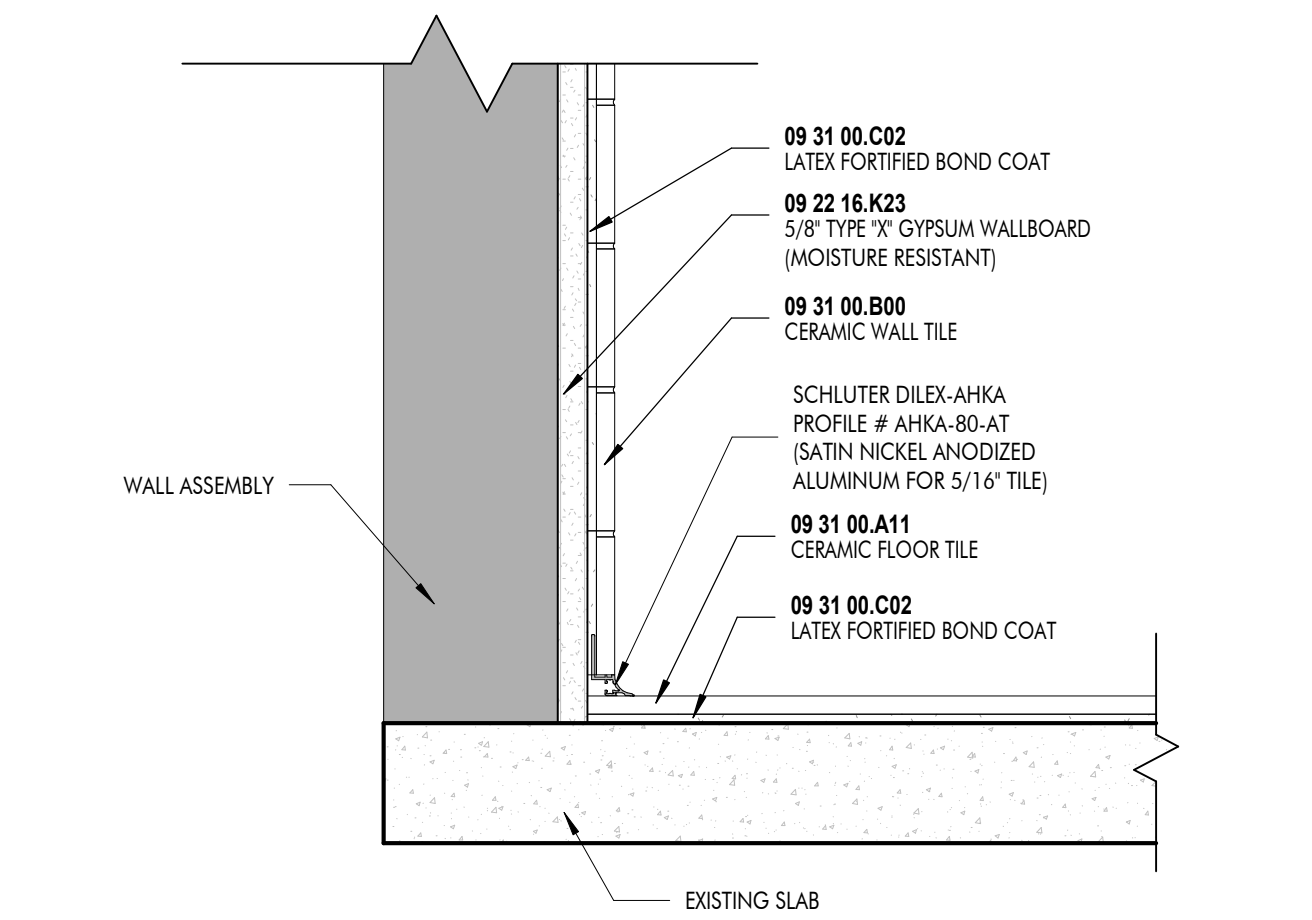

**4 CERAMIC WALL TILE - BASE**  
3" = 1'-0" DRAWN BY: KAS

ARCHITECT

**DOMAIN**  
ARCHITECTURE

8516 kelwood avenue, baton rouge, la 70806  
t: 225.216.3770 f: 225.216.3771  
www.domain-arch.com

REGISTRATION

STATE OF LOUISIANA  
REGISTERED ARCHITECT

These drawings are the property of DOMAIN ARCHITECTURE APAC and are not to be reproduced in whole or in part. They are only to be used for the project and site specifically identified herein. Scales stated hereon are valid on the original drawings only. Contractor shall carefully review all dimensions and conditions shown and report to the architect any errors, inconsistencies, or omissions discovered. These plans were prepared in the office under our personal supervision, and to the best of our knowledge comply with state and local codes. We will generally administer construction.

CLIENT

Southern University Laboratory School  
**RESTROOM RENOVATIONS**

129 SWAN AVE,  
BATON ROUGE, LA 70813

PROJECT INFORMATION

revisions	No.	Description	Date

project # **C22-0072**

date **AUGUST 31, 2023**

director review

FINISHES

**A9.00**

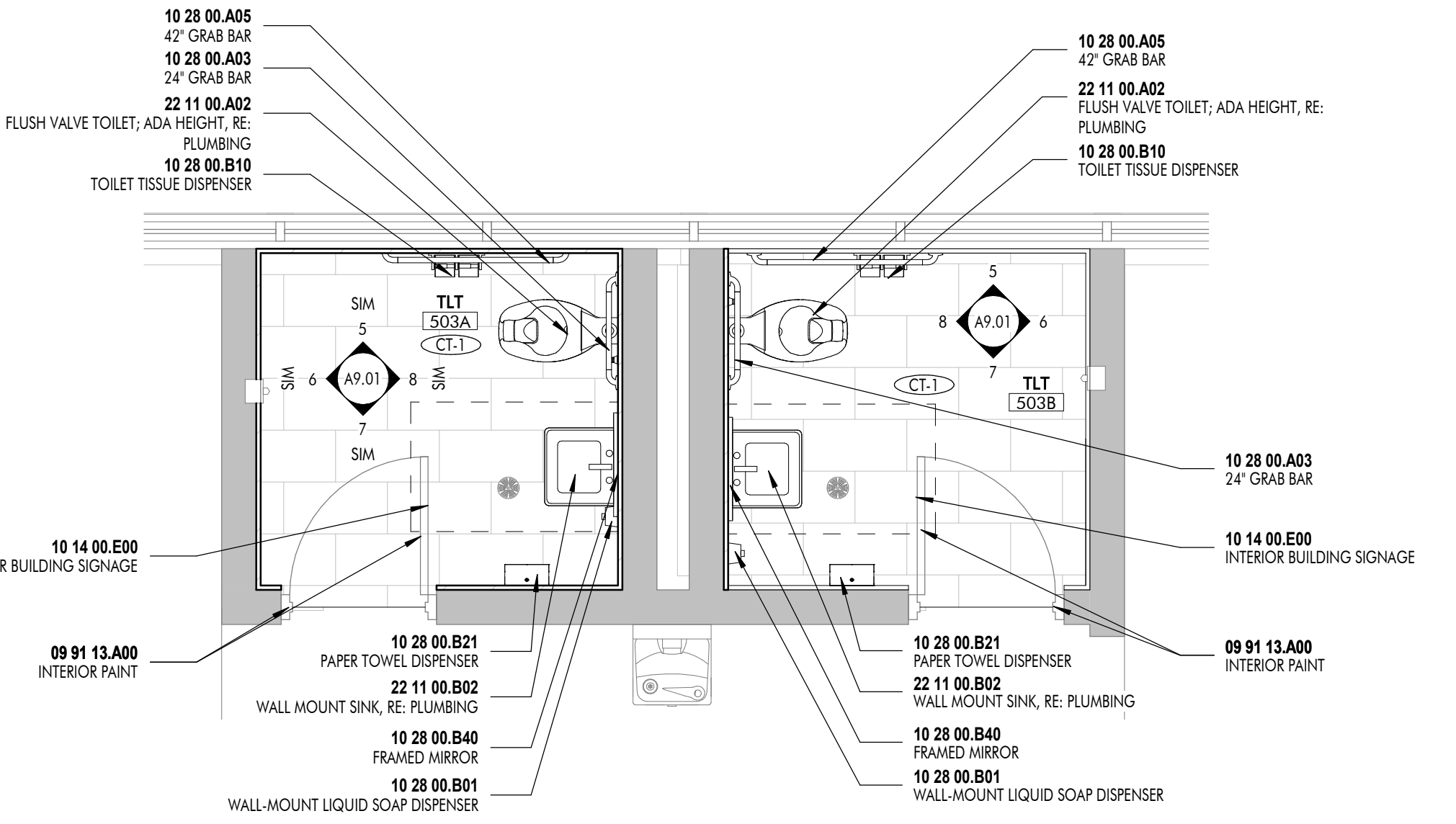
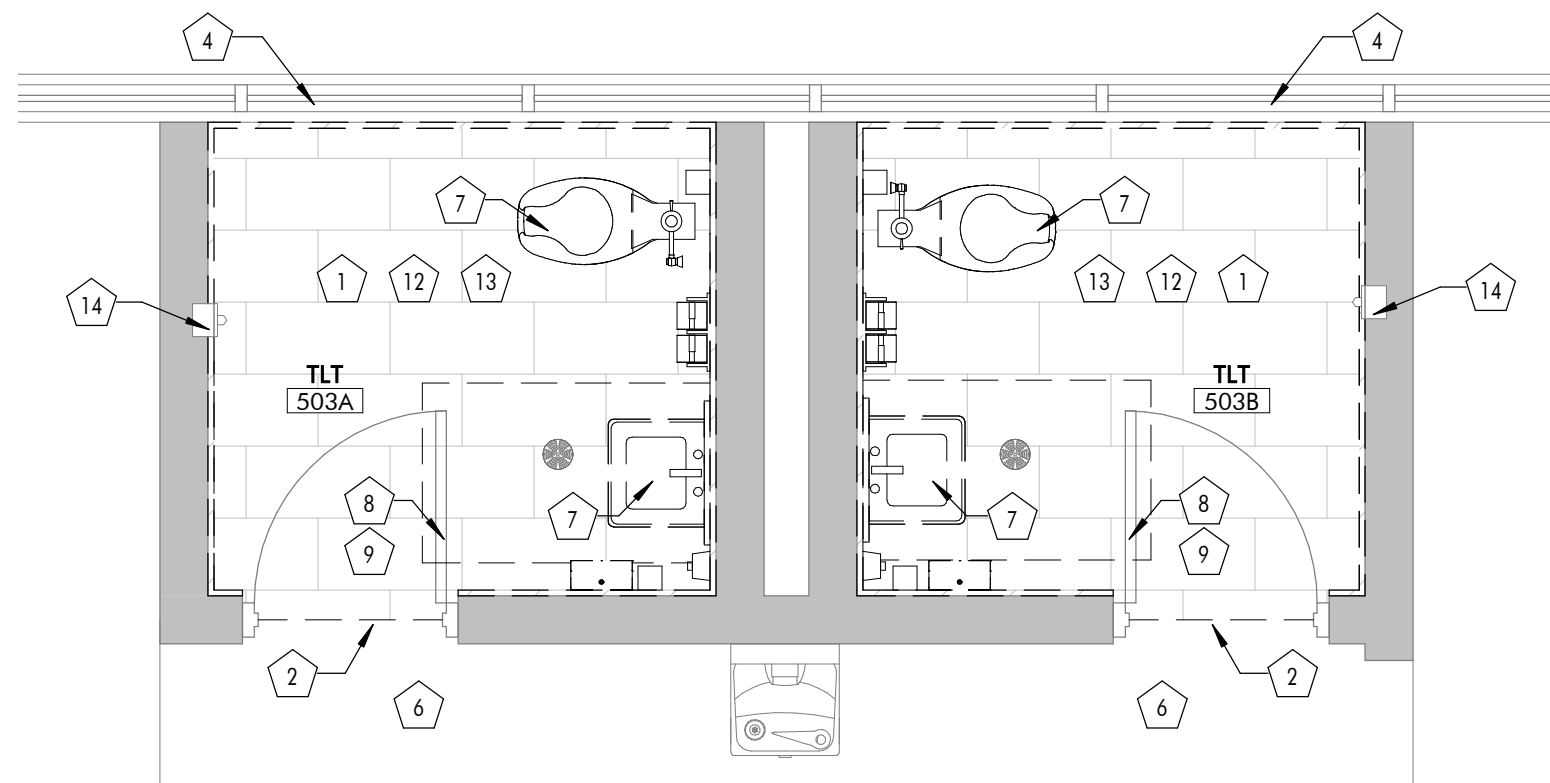

**1** KINDERGARDEN - DEMOLITION FLOOR PLAN  
3/8" = 1'-0" DRAWN BY: KAS

**2** KINDERGARDEN - NEW CONSTRUCTION FLOOR PLAN  
3/8" = 1'-0" DRAWN BY: KAS

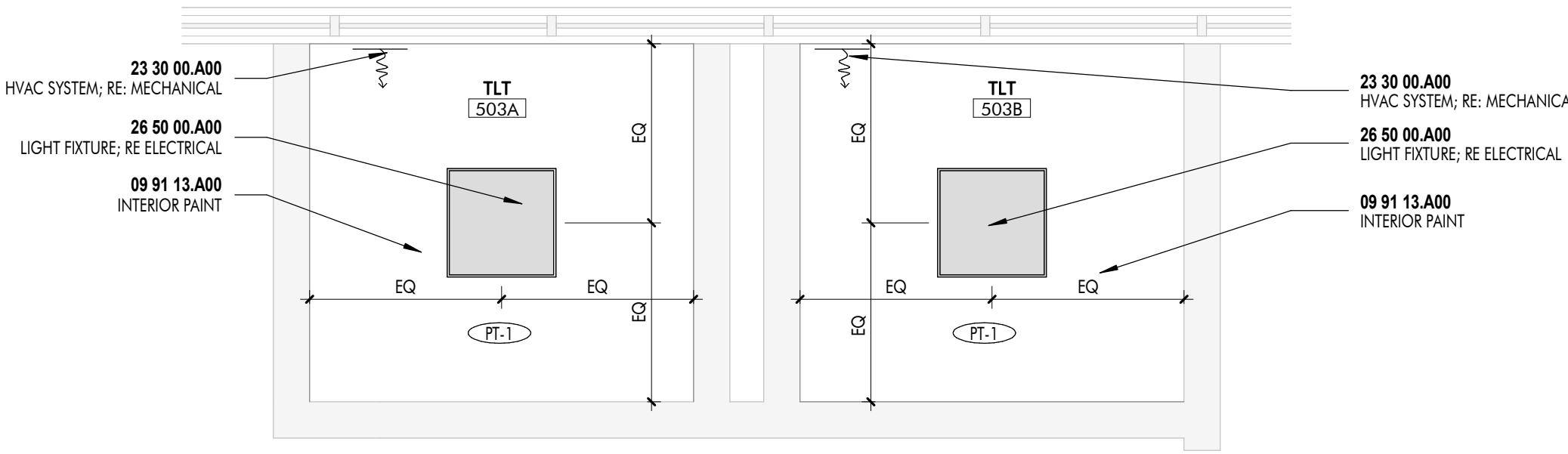
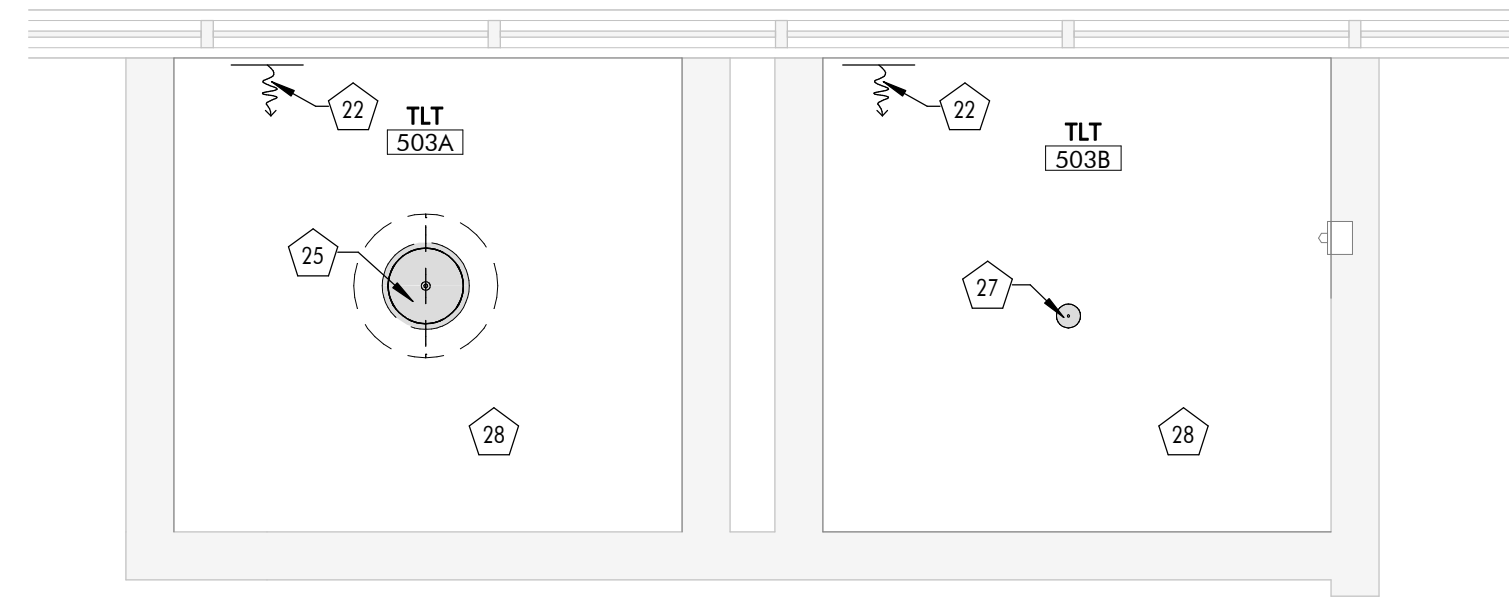

**3** KINDERGARDEN - DEMOLITION RCP  
3/8" = 1'-0" DRAWN BY: KAS

**4** KINDERGARDEN - NEW CONSTRUCTION RCP  
3/8" = 1'-0" DRAWN BY: KAS

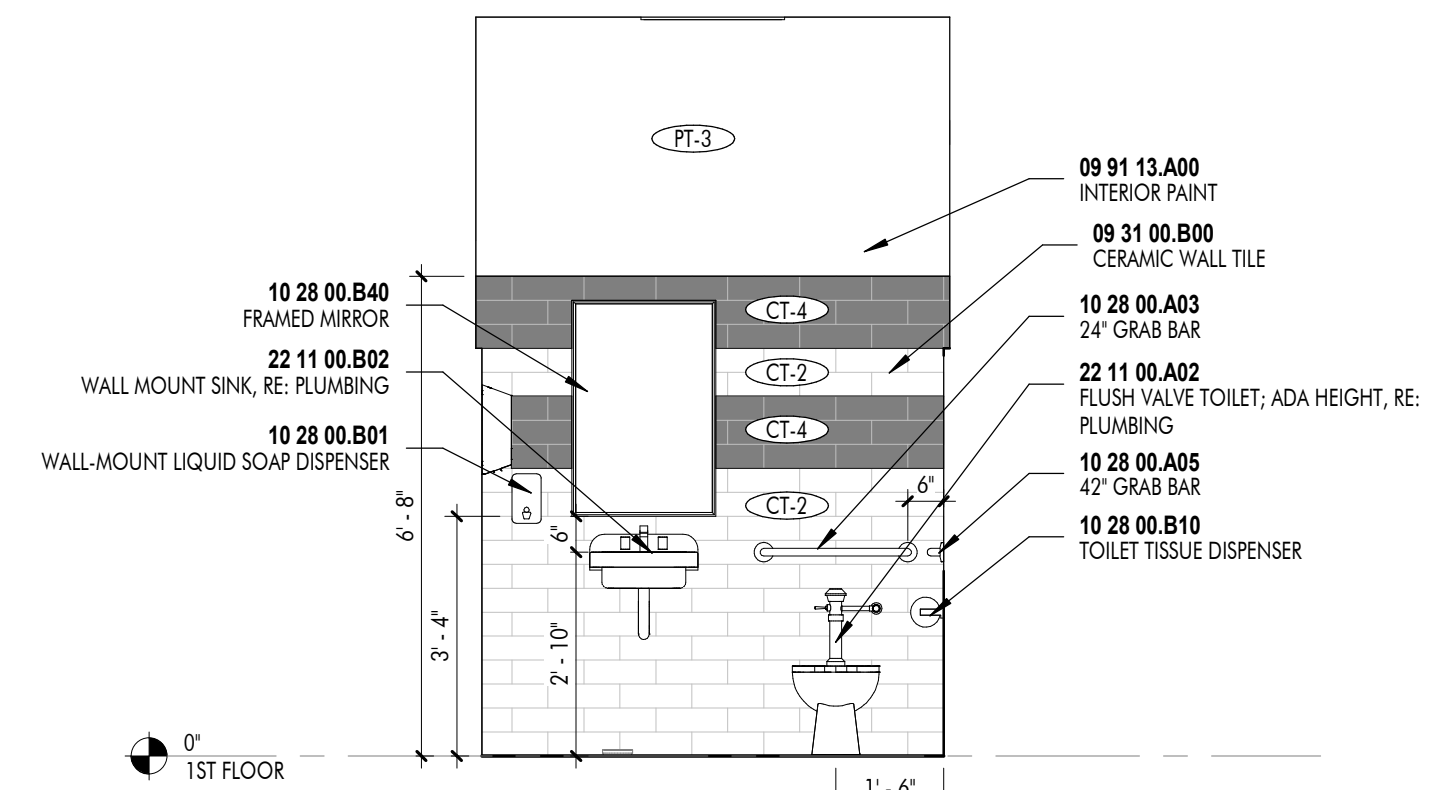
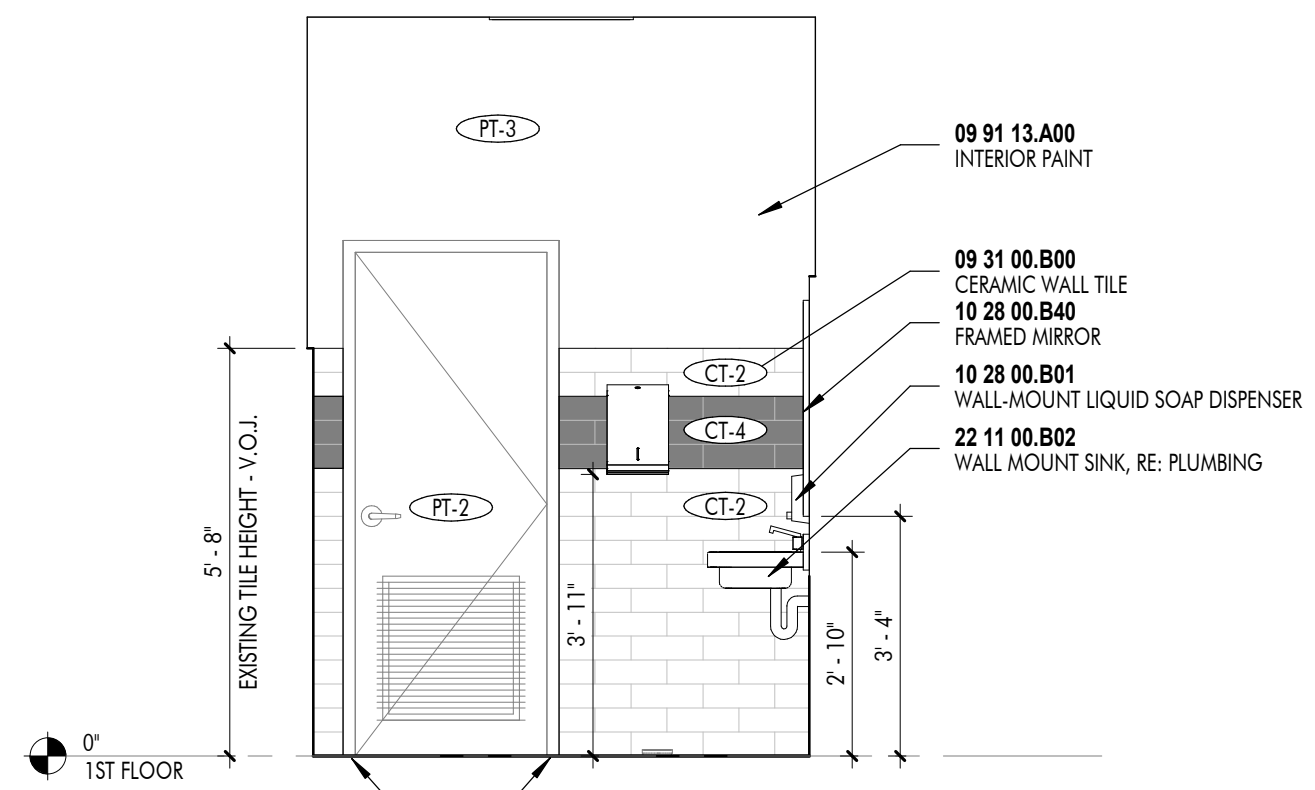
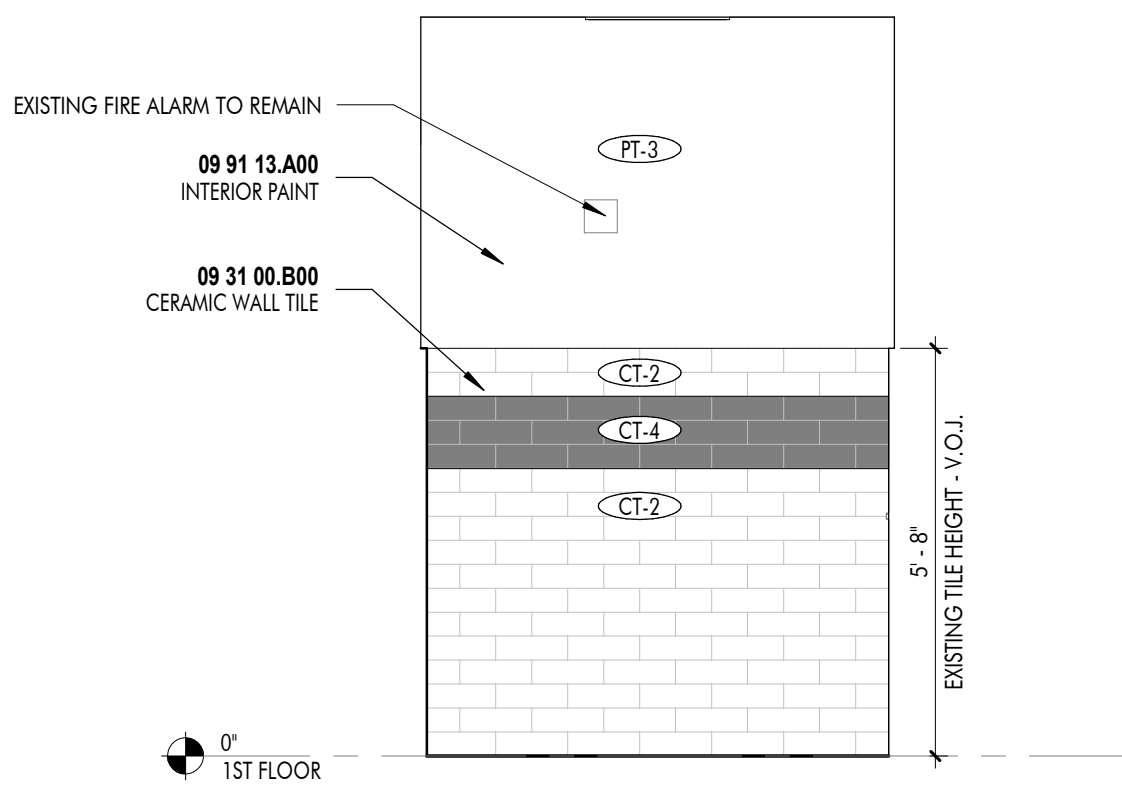
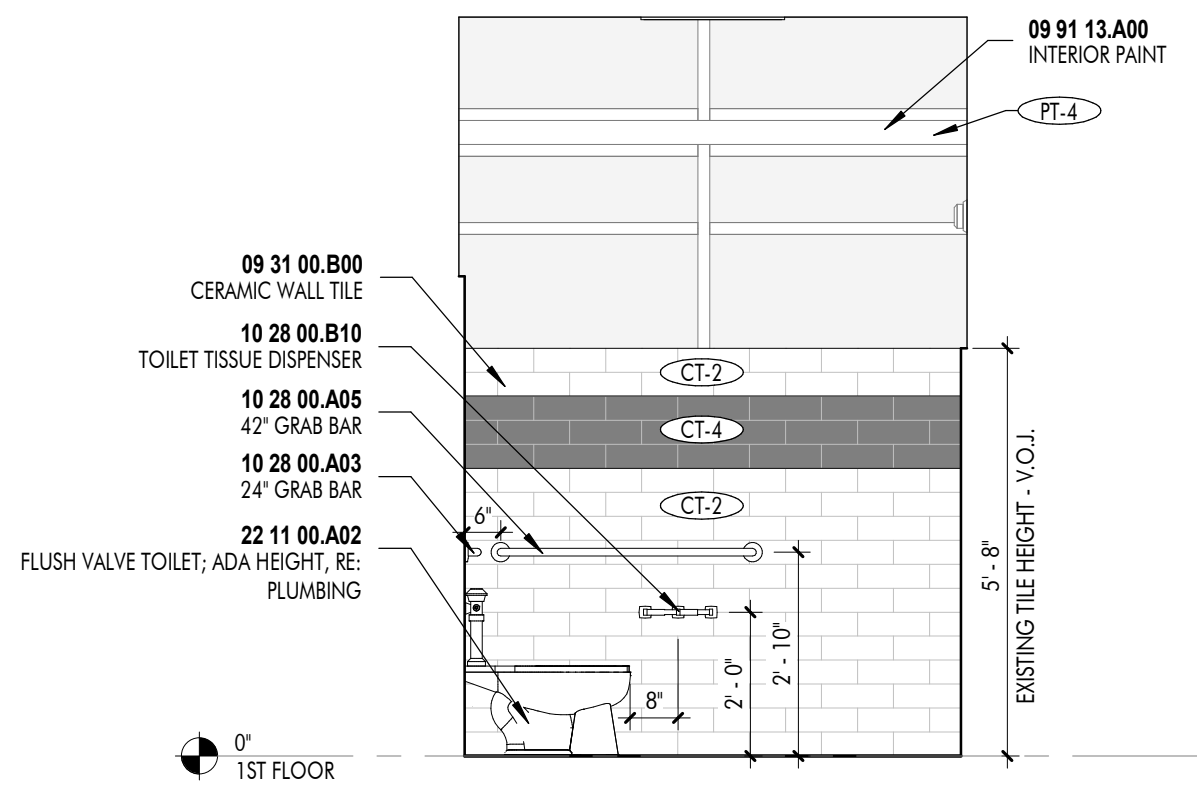

**5** KINDERGARDEN - NORTH  
3/8" = 1'-0" DRAWN BY: KAS

**6** KINDERGARDEN - EAST  
3/8" = 1'-0" DRAWN BY: KAS

**7** KINDERGARDEN - SOUTH  
3/8" = 1'-0" DRAWN BY: KAS

**8** KINDERGARDEN - WEST  
3/8" = 1'-0" DRAWN BY: KAS

CONSTRUCTION NOTES	
MARK	DESCRIPTION
1	REMOVE EXISTING FLOOR TILE. PATCH AND PREP FLOOR TO RECEIVE NEW TILE AS SCHEDULED. PROVIDE LEVELING COMPOUND AS NECESSARY. MOISTURE TEST EXISTING FLOOR BEFORE NEW FLOOR IS INSTALLED. THOROUGHLY CLEAN EXISTING FLOOR DRAIN.
2	MARBLE THRESHOLD TO BE PROTECTED FOR DURATION OF CONSTRUCTION. THRESHOLD TO BE CLEANED AT END OF CONSTRUCTION.
3	REMOVE DOORSTOP. PATCH AND PREP FLOOR TO RECEIVE NEW DOORSTOP.
4	REMOVE PAINT AND RUST FROM EXISTING STOREFRONT. PREP SURFACE TO RECEIVE NEW PAINT.
5	CONTRACTOR TO ENSURE WALL IS A FINISH LEVEL OF 4. REMOVE ANY FLAKING PAINT. SAND WALL FOR SMOOTH SURFACE AND PREP FOR NEW PAINT.
6	CAREFULLY REMOVE ANY EXISTING INTERIOR SIGNAGE. PATCH AND PREP WALL FOR NEW PAINT.
7	REMOVE EXISTING PLUMBING FIXTURE. MAINTAIN EXISTING PLUMBING FOR REUSE.
8	THOROUGHLY CLEAN DOOR, FRAME AND HARDWARE. RE-CAULK DOOR FRAME. RE: ABATEMENT DRAWINGS.
9	REMOVE EXISTING PAINT ON DOOR AND DOOR FRAME. PREP DOOR AND DOOR FRAME TO RECEIVE NEW PAINT. RE: ABATEMENT DRAWINGS.
10	CAREFULLY REMOVE DOOR, FRAME AND HARDWARE. PREP OPENING FOR NEW DOOR. RE: ABATEMENT DRAWINGS.
11	REMOVE TOILET PARTITIONS. PATCH AND PREP WALL FOR NEW PAINT.
12	REMOVE ALL EXISTING RESTROOM ACCESSORIES. (INCLUDING BUT NOT LIMITED TO MIRROR, TOILET PAPER HOLDER, GRAB BARS, SOAP DISPENSER, PAPER TOWEL DISPENSER, TOILET CLEANER)
13	CAREFULLY REMOVE EXISTING TILE ON WALLS. PATCH AND PREP WALL TO RECEIVE NEW TILE.
14	MAINTAIN AND PROTECT FIRE ALARM AND ALL RELATED CONDUIT.
15	CONTRACTOR TO ENSURE CEILING IS A FINISH LEVEL OF 4. REMOVE ANY FLAKING PAINT. SAND CEILING FOR SMOOTH SURFACE AND PREP FOR NEW PAINT.
16	REMOVE EXISTING RADIATOR AND ALL ACCESSORIES ASSOCIATED WITH IT. PATCH AND PREP WALL.
17	PATCH HOLE IN THE WALL. PREP SURFACE TO RECEIVE NEW TILE.
18	REMOVE EXISTING LOCKERS.
19	REMOVE CONCRETE CURB. PROTECT SURROUNDING CONCRETE.
20	REMOVE EXISTING BENCH. PATCH AND PREP CONCRETE TO RECEIVE NEW SEAL.
21	REMOVE CEILING TILE AND GRID. PATCH AND PREP WALL TO RECEIVE NEW CEILING.
22	CAREFULLY REMOVE AND SALVAGE SUPPLY VENT FOR REUSE. REMOVE ANY PAINT FROM SURFACE AND CLEAN THOROUGHLY.
23	CAREFULLY REMOVE AND SALVAGE RETURN VENT FOR REUSE. REMOVE ANY PAINT FROM SURFACE AND CLEAN THOROUGHLY.
24	CAREFULLY REMOVE AND SALVAGE EXHAUST FAN FOR REUSE. REMOVE ANY PAINT FROM SURFACE AND CLEAN THOROUGHLY.
25	CAREFULLY REMOVE SURFACE MOUNTED LIGHT FIXTURE. ELECTRICAL TO REMAIN FOR REUSE.
26	REMOVE ALL LIGHT FIXTURES FROM ENTIRE ROOM. ELECTRICAL TO REMAIN FOR REUSE. CAP ANY ELECTRICAL NOT REUSED.
27	CAREFULLY REMOVE HANGING LIGHT FIXTURE. ELECTRICAL TO REMAIN FOR REUSE.
28	PREP PLASTER CEILING TO RECEIVE NEW PAINT.
29	PREP METAL CEILING TO RECEIVE NEW PAINT.
30	REMOVE DOOR, FRAME AND HARDWARE. PREPARE OPENING TO BE INFILLED.
31	REMOVE PORTION OF EXISTING WALL TO RECEIVE NEW DOOR.
A	MAIN STAGING AREA FOR CONTRACTOR
B	SUB-STAGING / PARKING AREA
C	STAGING AREAS SHALL BE REGRADED AND SEEDED WHEN THE CONSTRUCTION PROJECT HAS BEEN COMPLETED.
D	STAGING AREAS MUST BE FENCED AND LOCKABLE ALL TIMES.

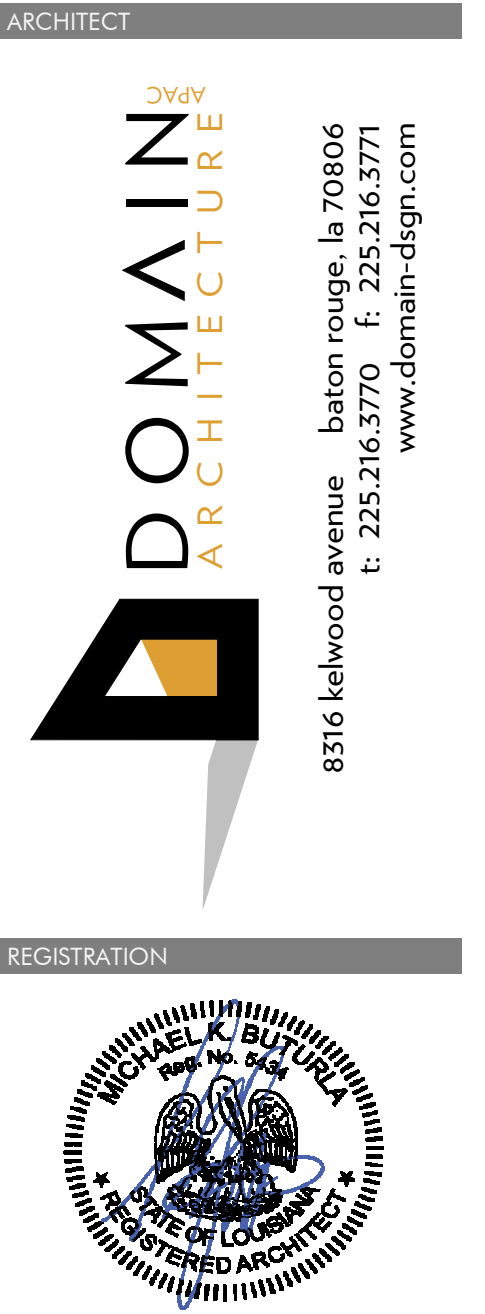

816 kelwood  
avenue  
baton rouge, la 70806  
t: 225.216.3770 f: 225.216.3771  
www.domain-arch.com



These drawings are the property of DOMAIN ARCHITECTURE APC and are not to be reproduced in whole or in part. They are only to be used for the project and site specifically identified herein. Scales stated herein are valid on the original drawings only. Contractor shall carefully review all dimensions and conditions shown and report to the architect any errors, inconsistencies, or omissions discovered. These plans were prepared in the office under our personal supervision, and to the best of our knowledge comply with state and local codes. We will generally administer construction.

**Southern University Laboratory School**  
**RESTROOM RENOVATIONS**

PROJECT INFORMATION	
No.	Description

project # C22-0072  
date AUGUST 31, 2023  
director review

KINDERGARTEN

**A9.01**

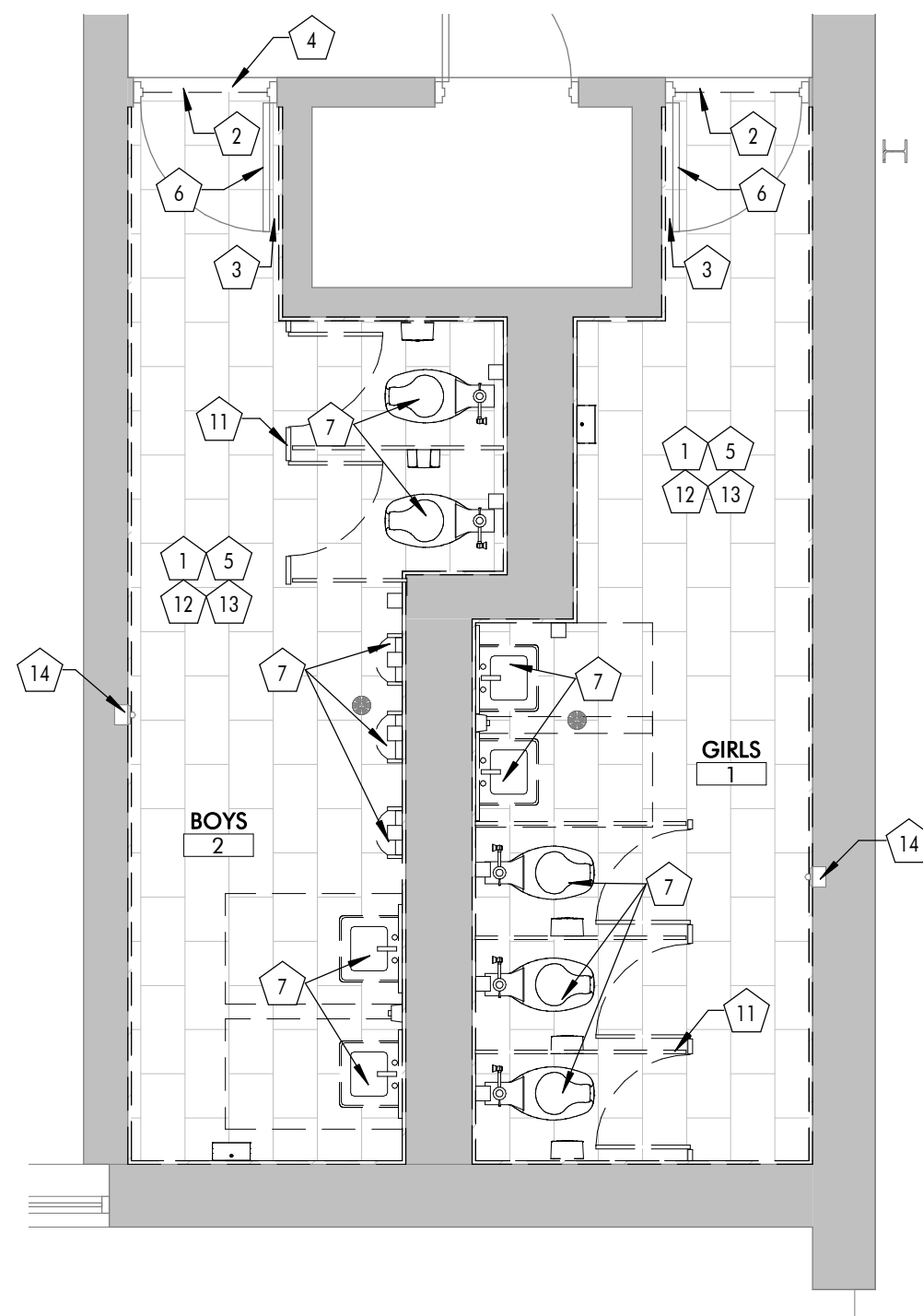

**1** 1ST FLOOR EXTERIOR BATHROOMS - DEMOLITION PLAN  
1/4" = 1'-0" DRAWN BY: KAS

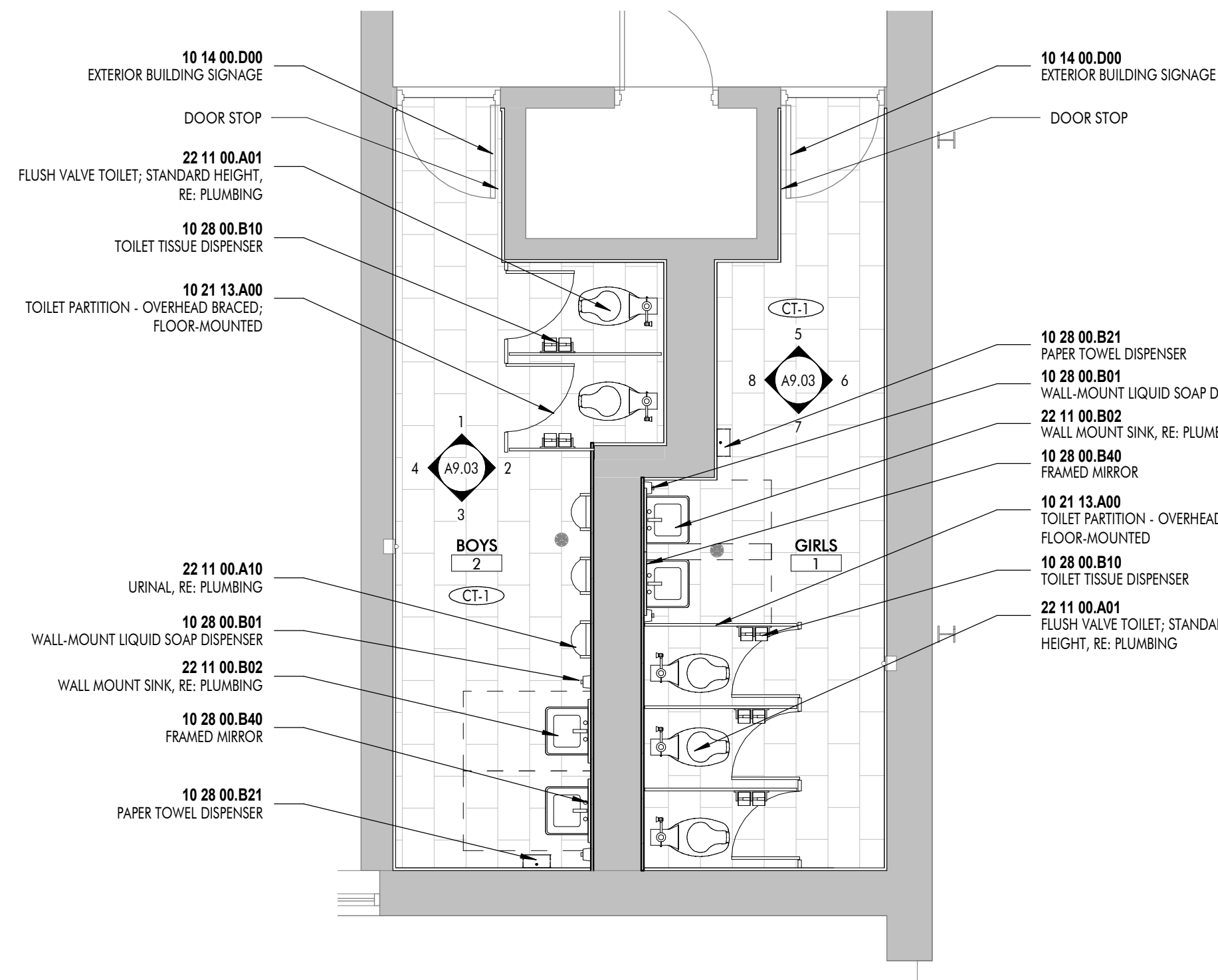

**2** 1ST FLOOR EXTERIOR BATHROOMS - NEW CONSTRUCTION PLAN  
1/4" = 1'-0" DRAWN BY: KAS

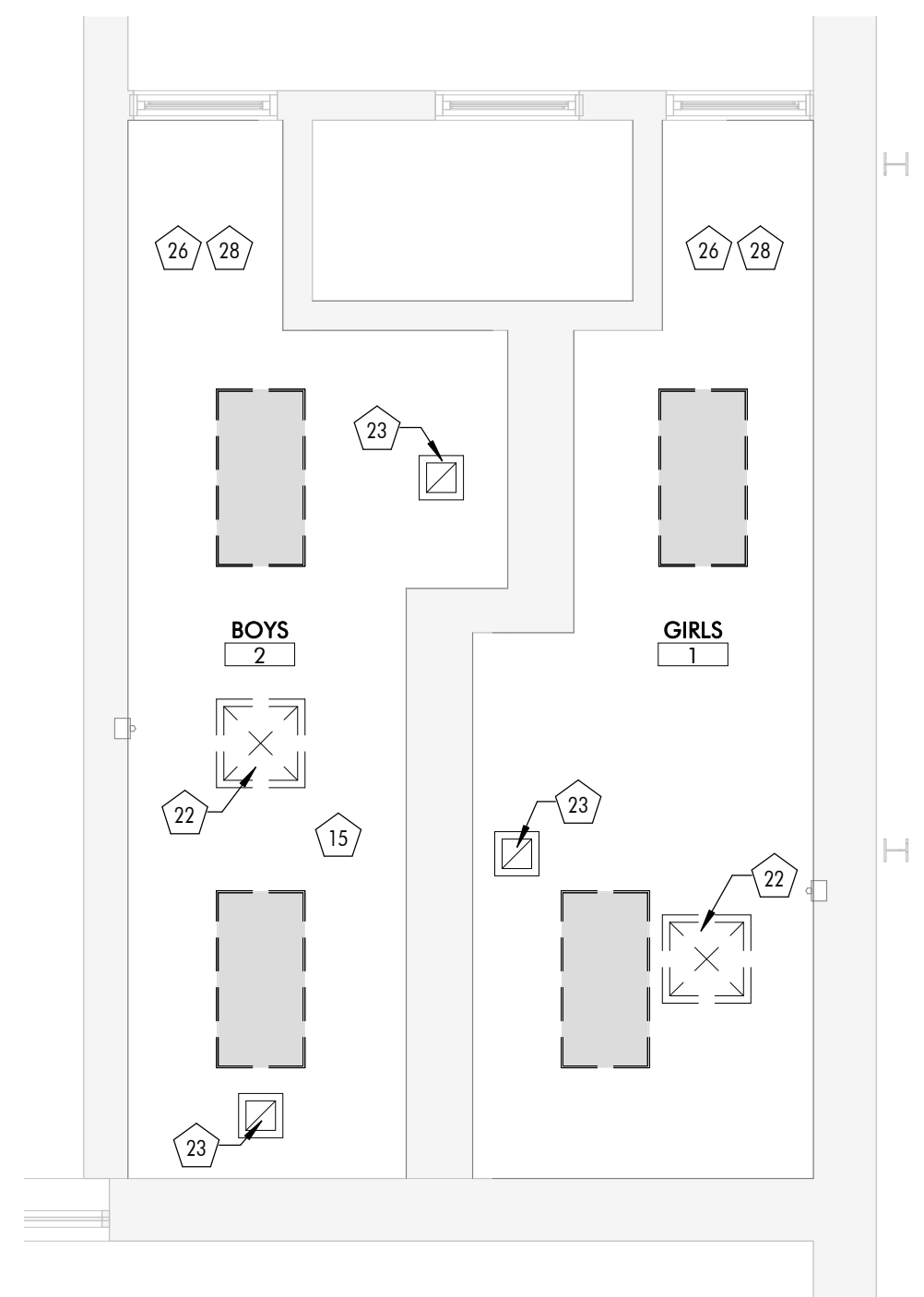

**3** 1ST FLOOR EXTERIOR BATHROOMS - DEMOLITION PLAN  
1/4" = 1'-0" DRAWN BY: KAS

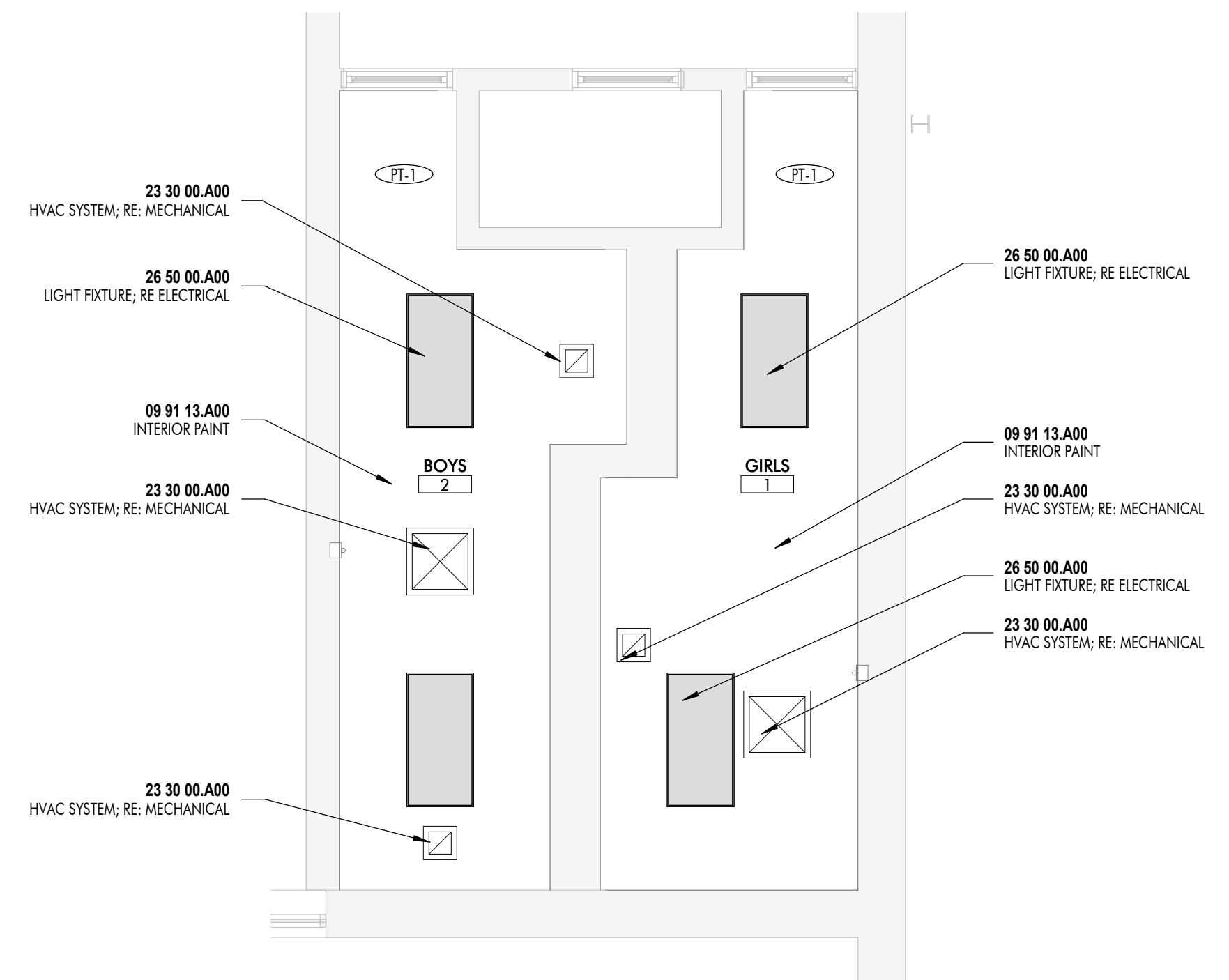

**4** 1ST FLOOR EXTERIOR BATHROOMS - NEW CONSTRUCTION PLAN  
1/4" = 1'-0" DRAWN BY: KAS

CONSTRUCTION NOTES	
MARK	DESCRIPTION
1	REMOVE EXISTING FLOOR TILE. PATCH AND PREP FLOOR TO RECEIVE NEW TILE AS SCHEDULED. PROVIDE LEVELING COMPOUND AS NECESSARY. MOISTURE TEST EXISTING FLOOR BEFORE NEW FLOOR IS INSTALLED. THOROUGHLY CLEAN EXISTING FLOOR DRAIN.
2	MARBLE THRESHOLD TO BE PROTECTED FOR DURATION OF CONSTRUCTION. THRESHOLD TO BE CLEANED AT END OF CONSTRUCTION.
3	REMOVE DOORSTOP. PATCH AND PREP FLOOR TO RECEIVE NEW DOORSTOP.
4	REMOVE PAINT AND RUST FROM EXISTING STOREFRONT. PREP SURFACE TO RECEIVE NEW PAINT.
5	CONTRACTOR TO ENSURE WALL IS A FINISH LEVEL OF 4. REMOVE ANY FLAKING PAINT. SAND WALL FOR SMOOTH SURFACE AND PREP FOR NEW PAINT.
6	CAREFULLY REMOVE ANY EXISTING INTERIOR SIGNAGE. PATCH AND PREP WALL FOR NEW PAINT.
7	REMOVE EXISTING PLUMBING FIXTURE. MAINTAIN EXISTING PLUMBING FOR REUSE.
8	THOROUGHLY CLEAN DOOR, FRAME AND HARDWARE. RE-CAULK DOOR FRAME. RE: ABATEMENT DRAWINGS.
9	REMOVE EXISTING PAINT ON DOOR AND DOOR FRAME. PREP DOOR AND DOOR FRAME TO RECEIVE NEW PAINT. RE: ABATEMENT DRAWINGS.
10	CAREFULLY REMOVE DOOR, FRAME AND HARDWARE. PREP OPENING FOR NEW DOOR. RE: ABATEMENT DRAWINGS.
11	REMOVE TOILET PARTITIONS. PATCH AND PREP WALL FOR NEW PAINT.
12	REMOVE ALL EXISTING RESTROOM ACCESSORIES. (INCLUDING BUT NOT LIMITED TO MIRROR, TOILET PAPER HOLDER, GRAB BARS, SOAP DISPENSER, PAPER TOWEL DISPENSER, TOILET CLEANER)
13	CAREFULLY REMOVE EXISTING TILE ON WALLS. PATCH AND PREP WALL TO RECEIVE NEW TILE.
14	MAINTAIN AND PROTECT FIRE ALARM AND ALL RELATED CONDUIT.
15	CONTRACTOR TO ENSURE CEILING IS A FINISH LEVEL OF 4. REMOVE ANY FLAKING PAINT. SAND CEILING FOR SMOOTH SURFACE AND PREP FOR NEW PAINT.
16	REMOVE EXISTING RADIATOR AND ALL ACCESSORIES ASSOCIATED WITH IT. PATCH AND PREP WALL.
17	PATCH HOLE IN THE WALL. PREP SURFACE TO RECEIVE NEW TILE.
18	REMOVE EXISTING LOCKERS.
19	REMOVE CONCRETE CURB. PROTECT SURROUNDING CONCRETE.
20	REMOVE EXISTING BENCH. PATCH AND PREP CONCRETE TO RECEIVE NEW SEAL.
21	REMOVE CEILING TILE AND GRID. PATCH AND PREP WALL TO RECEIVE NEW CEILING.
22	CAREFULLY REMOVE AND SALVAGE SUPPLY VENT FOR REUSE. REMOVE ANY PAINT FROM SURFACE AND CLEAN THOROUGHLY.
23	CAREFULLY REMOVE AND SALVAGE RETURN VENT FOR REUSE. REMOVE ANY PAINT FROM SURFACE AND CLEAN THOROUGHLY.
24	CAREFULLY REMOVE AND SALVAGE EXHAUST FAN FOR REUSE. REMOVE ANY PAINT FROM SURFACE AND CLEAN THOROUGHLY.
25	CAREFULLY REMOVE SURFACE MOUNTED LIGHT FIXTURE. ELECTRICAL TO REMAIN FOR REUSE.
26	REMOVE ALL LIGHT FIXTURES FROM ENTIRE ROOM. ELECTRICAL TO REMAIN FOR REUSE. CAP ANY ELECTRICAL NOT REUSED.
27	CAREFULLY REMOVE HANGING LIGHT FIXTURE. ELECTRICAL TO REMAIN FOR REUSE.
28	PREP PLASTER CEILING TO RECEIVE NEW PAINT.
29	PREP METAL CEILING TO RECEIVE NEW PAINT.
30	REMOVE DOOR, FRAME AND HARDWARE. PREP OPENING TO BE INFILLED.
31	REMOVE PORTION OF EXISTING WALL TO RECEIVE NEW DOOR.
A	MAIN STAGING AREA FOR CONTRACTOR
B	SUB-STAGING / PARKING AREA
C	STAGING AREAS SHALL BE REGRADED AND SEEDED WHEN THE CONSTRUCTION PROJECT HAS BEEN COMPLETED.
D	STAGING AREAS MUST BE FENCED AND LOCKABLE ALL TIMES.

ARCHITECT

**DOMAINE ARCHITECTURE**  
APAC

8316 kelwood  
avenue, baton rouge, la 70806  
t: 225.216.5770 f: 225.216.5771  
www.domain-arch.com

REGISTRATION

CLIENT

These drawings are the property of DOMAINE ARCHITECTURE APAC and are not to be reproduced in whole or in part. They are only to be used for the project and site specifically identified herein. Scales stated herein are valid on the original drawings only. Contractor shall carefully review all dimensions and conditions shown and report to the architect any errors, inconsistencies, or omissions discovered. These plans were prepared in this office under our personal supervision, and to the best of our knowledge comply with state and local codes. We will generally administer construction.

Southern University Laboratory School  
**RESTROOM RENOVATIONS**

PROJECT INFORMATION

129 SWAN AVE,  
BATON ROUGE, LA 70813

revisions	No.	Description	Date

project # C22-0072

date AUGUST 31, 2023

director review

EXTERIOR BATHROOM PLANS

AUGUST 31, 2023

PROJECT INFORMATION

revisions	No.	Description	Date

project # **C22-0072**

date **AUGUST 31, 2023**

director review

EXTERIOR BATHROOM ELEVATIONS

**A9.03**

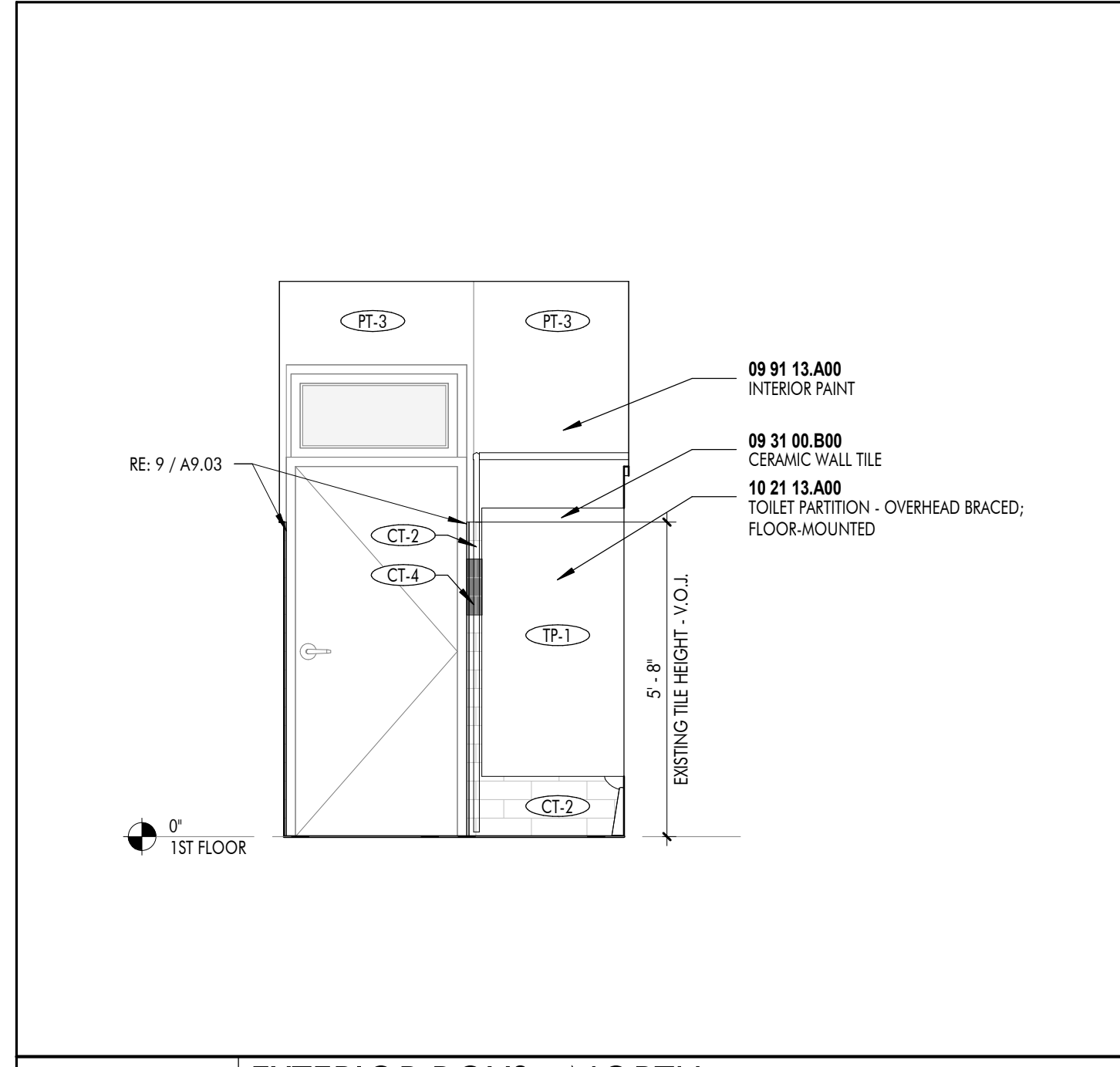

**1** EXTERIOR BOYS - NORTH  
3/8" = 1'-0" DRAWN BY: KAS

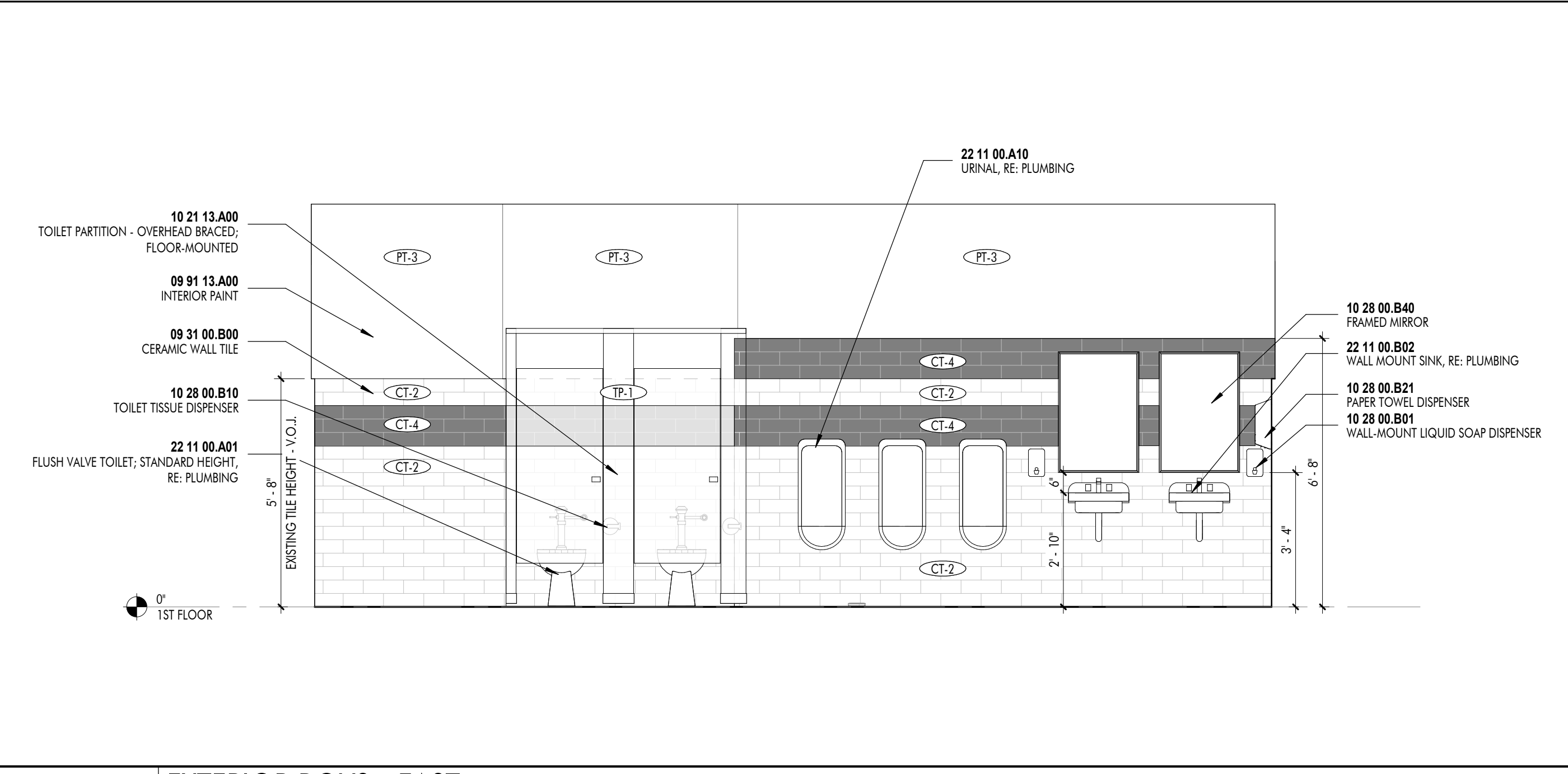

**2** EXTERIOR BOYS - EAST  
3/8" = 1'-0" DRAWN BY: KAS

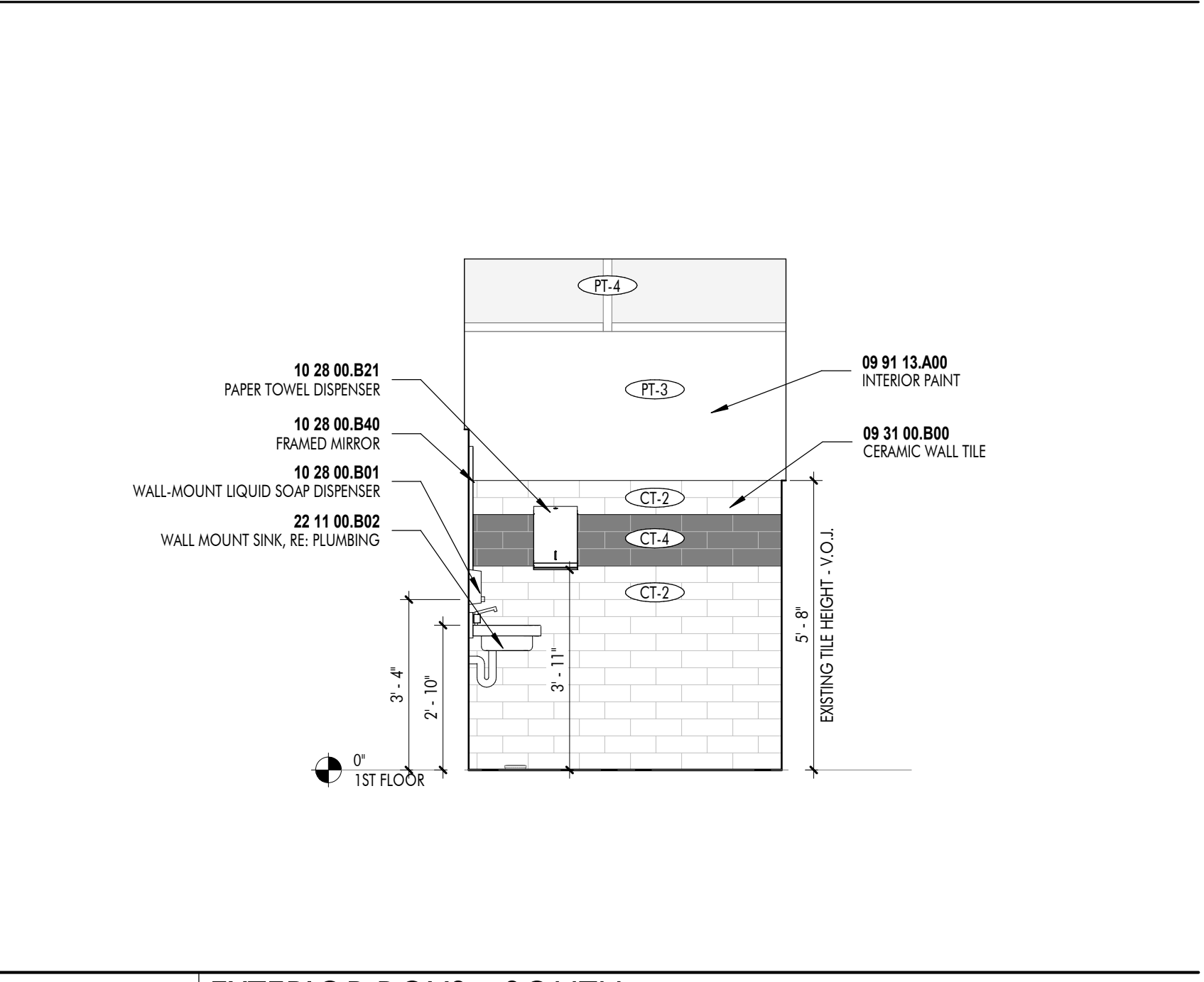

**3** EXTERIOR BOYS - SOUTH  
3/8" = 1'-0" DRAWN BY: KAS

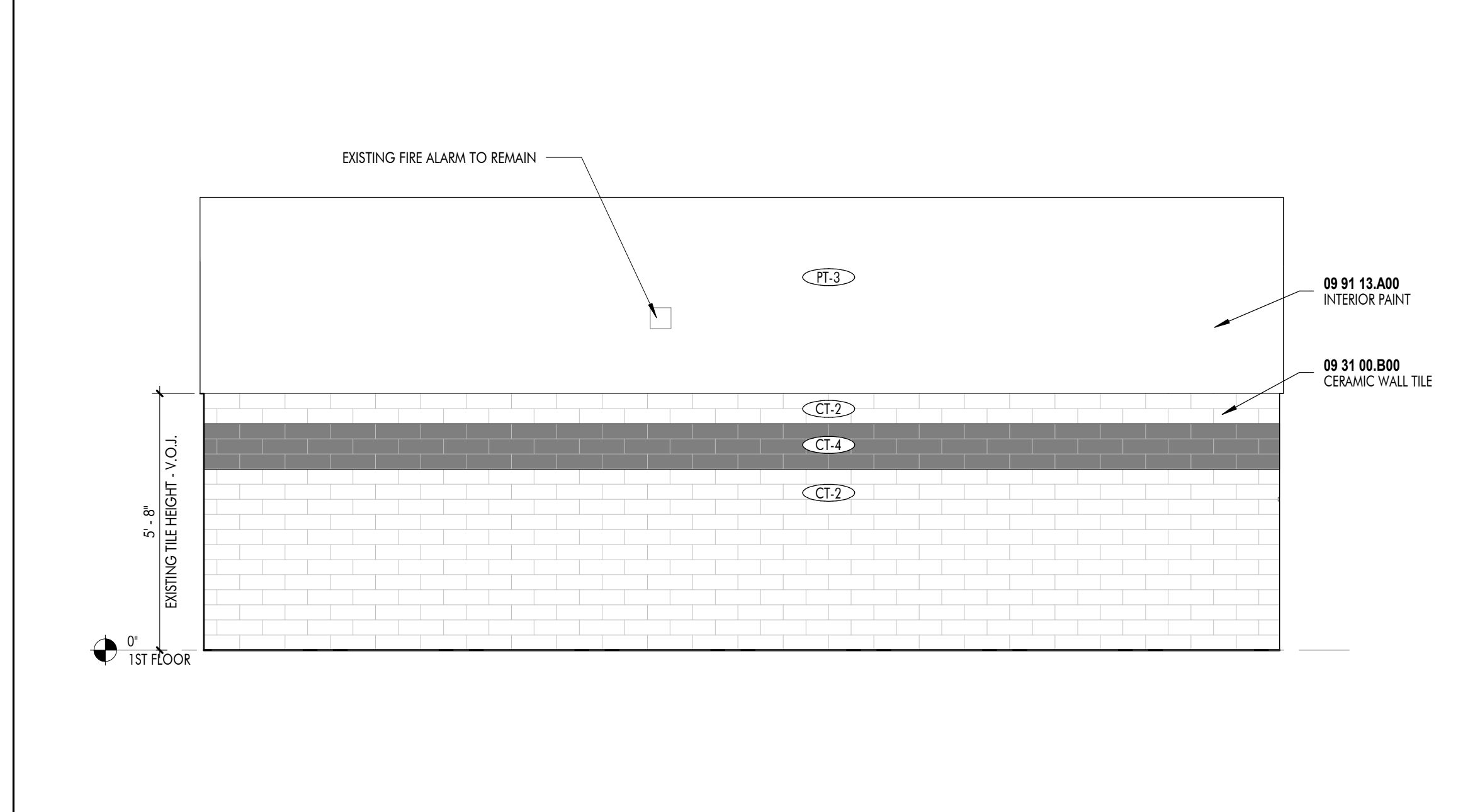

**4** EXTERIOR BOYS - WEST  
3/8" = 1'-0" DRAWN BY: KAS

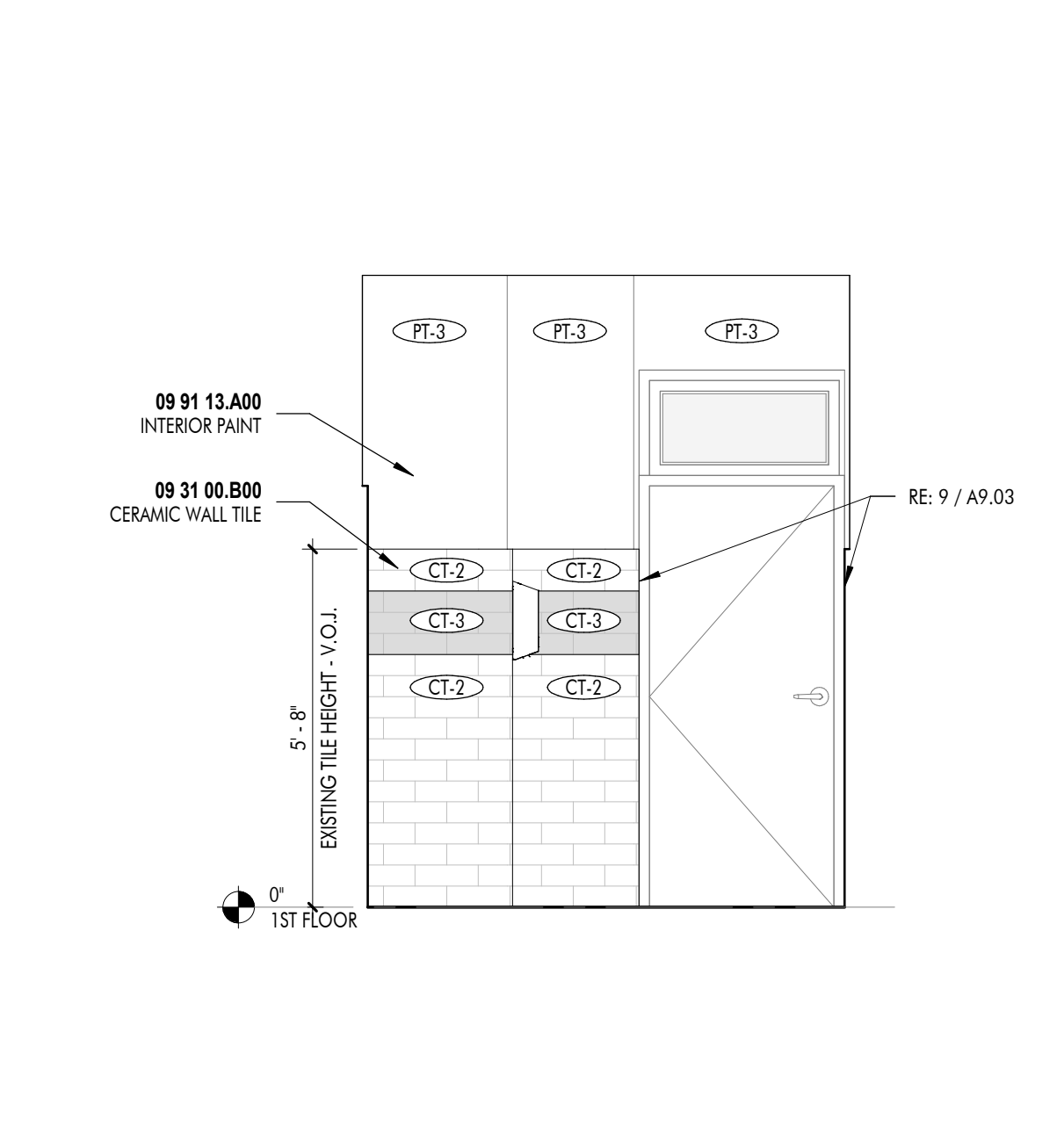

**5** EXTERIOR GIRLS - NORTH  
3/8" = 1'-0" DRAWN BY: KAS

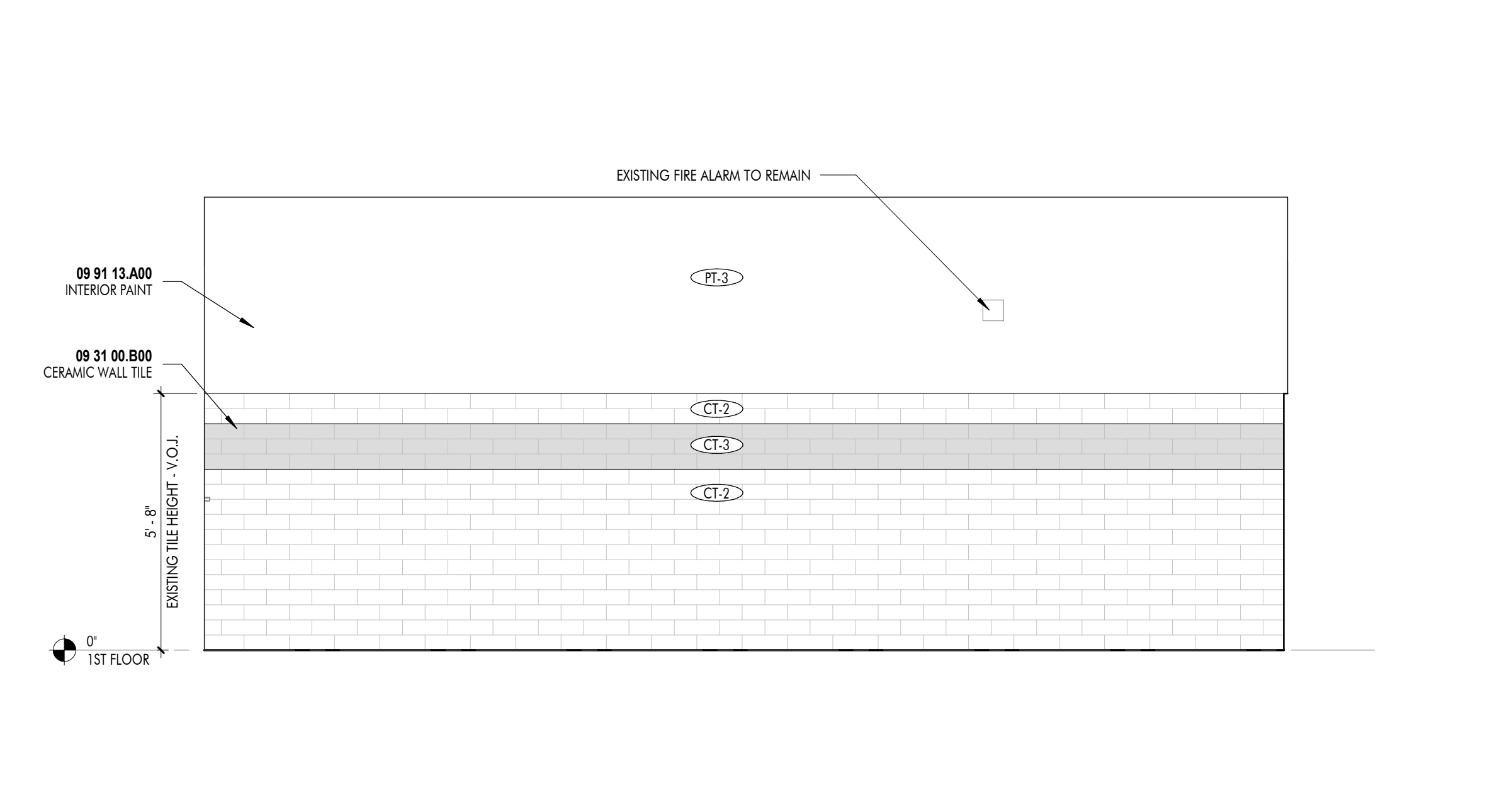

**6** EXTERIOR GIRLS - EAST  
3/8" = 1'-0" DRAWN BY: KAS

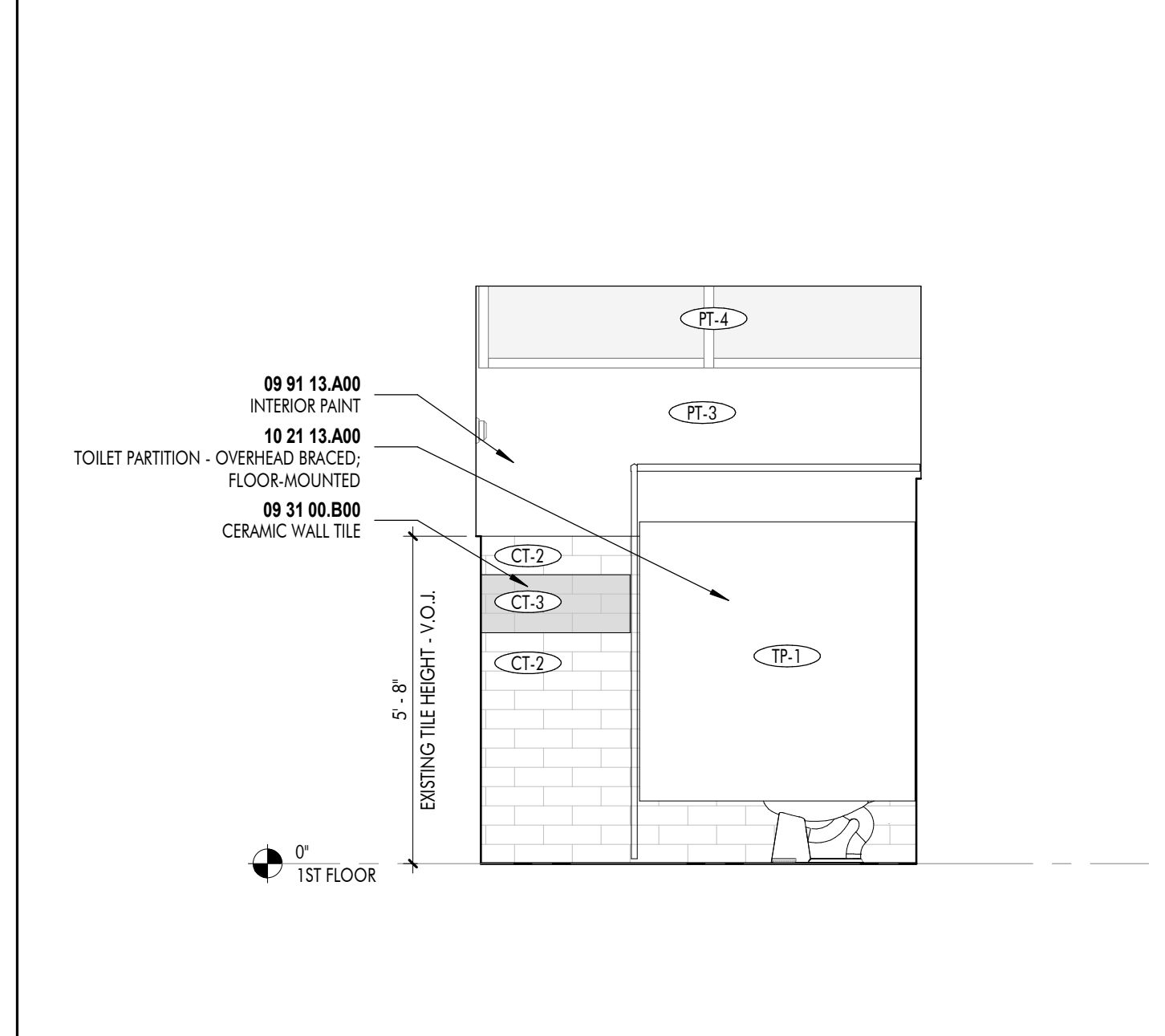

**7** EXTERIOR GIRLS - SOUTH  
3/8" = 1'-0" DRAWN BY: KAS

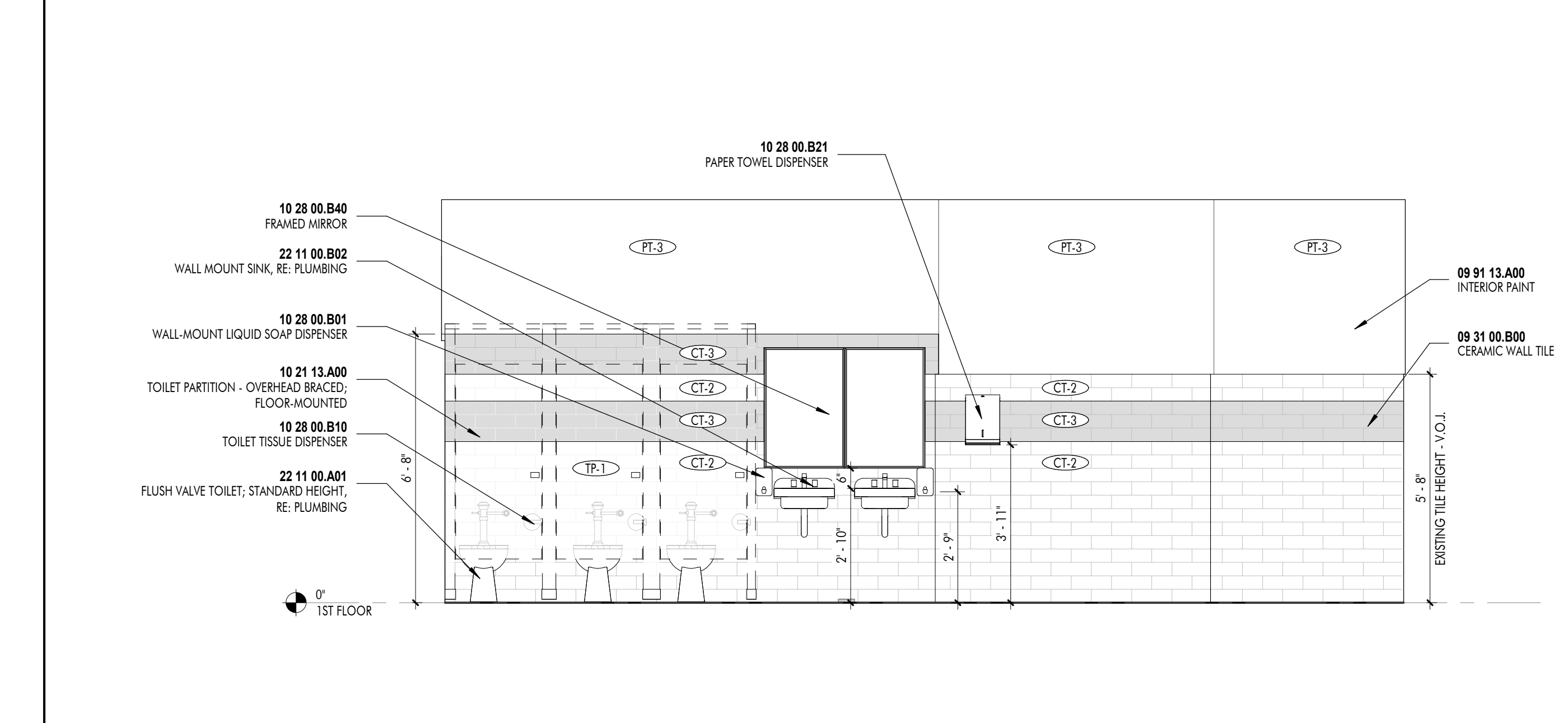

**8** EXTERIOR GIRLS - WEST  
3/8" = 1'-0" DRAWN BY: KAS

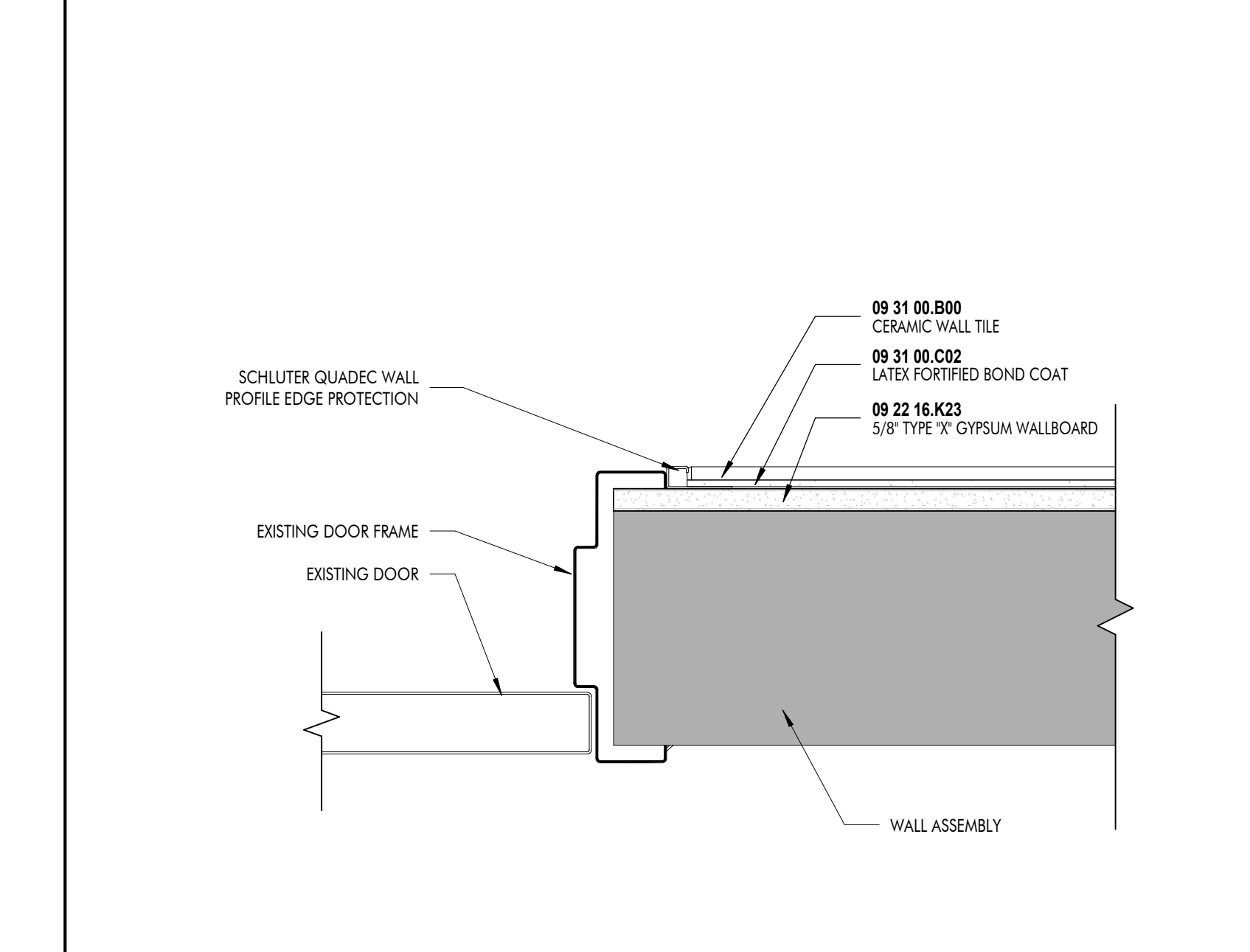

**9** SCHLUTER JAMB  
3" = 1'-0" DRAWN BY: KAS



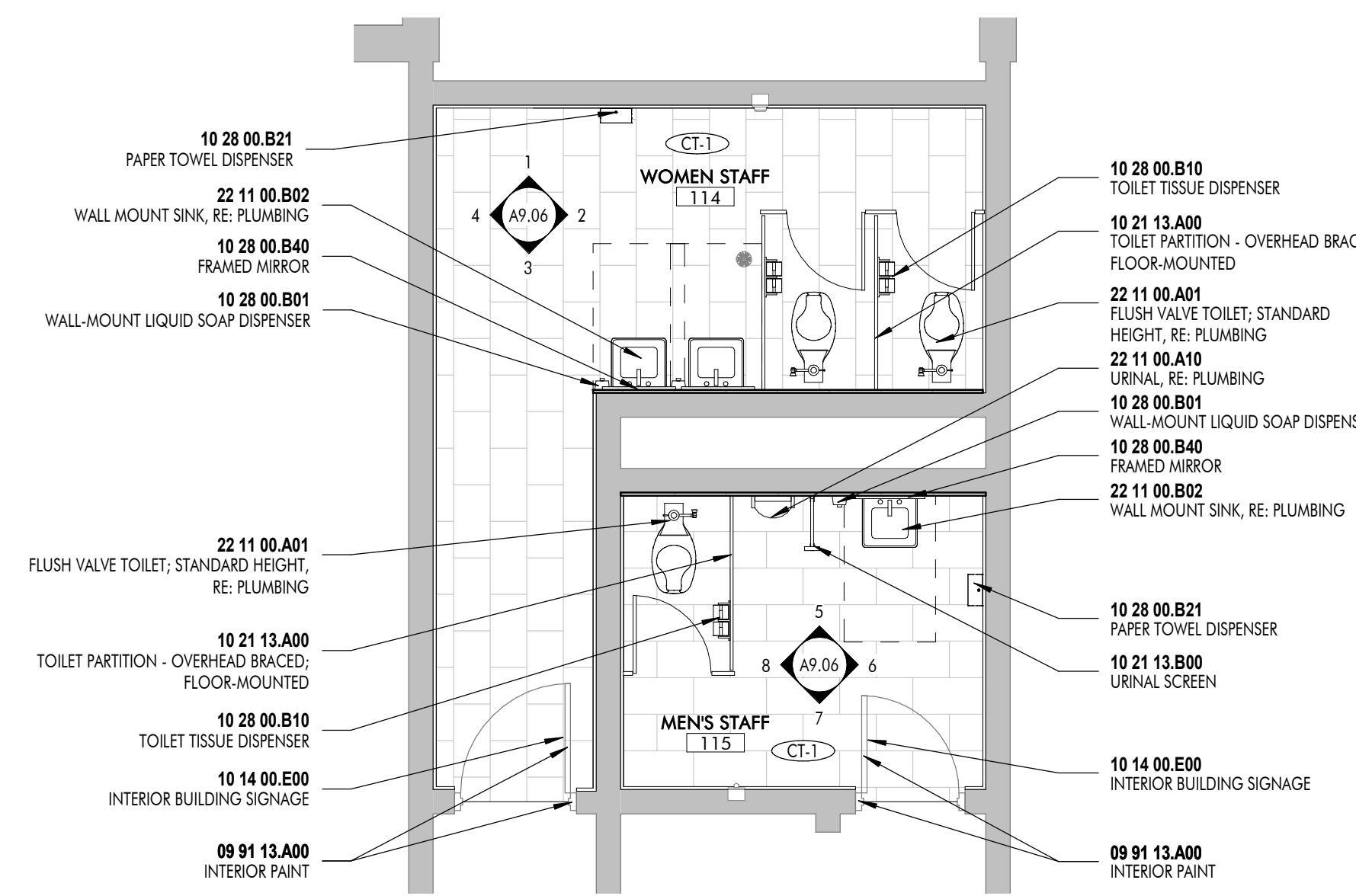
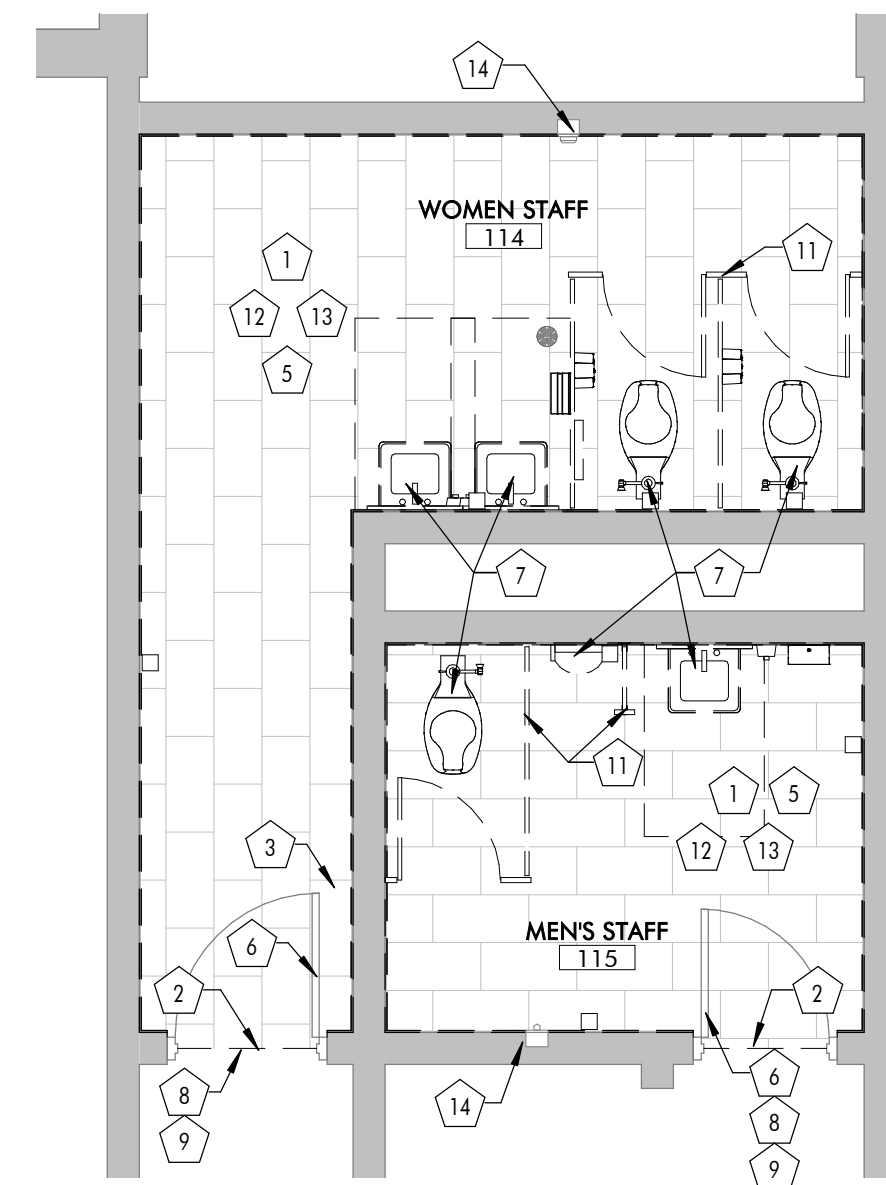

CONSTRUCTION NOTES	
MARK	DESCRIPTION
1	REMOVE EXISTING FLOOR TILE. PATCH AND PREP FLOOR TO RECEIVE NEW TILE AS SCHEDULED. PROVIDE LEVELING COMPOUND AS NECESSARY. MOISTURE TEST EXISTING FLOOR BEFORE NEW FLOOR IS INSTALLED. THOROUGHLY CLEAN EXISTING FLOOR DRAIN.
2	MARBLE THRESHOLD TO BE PROTECTED FOR DURATION OF CONSTRUCTION. THRESHOLD TO BE CLEANED AT END OF CONSTRUCTION.
3	REMOVE DOORSTOP. PATCH AND PREP FLOOR TO RECEIVE NEW DOORSTOP.
4	REMOVE PAINT AND RUST FROM EXISTING STOREFRONT. PREP SURFACE TO RECEIVE NEW PAINT.
5	CONTRACTOR TO ENSURE WALL IS A FINISH LEVEL OF 4. REMOVE ANY FLAKING PAINT. SAND WALL FOR SMOOTH SURFACE AND PREP FOR NEW PAINT.
6	CAREFULLY REMOVE ANY EXISTING INTERIOR SIGNAGE. PATCH AND PREP WALL FOR NEW PAINT.
7	REMOVE EXISTING PLUMBING FIXTURE. MAINTAIN EXISTING PLUMBING FOR REUSE.
8	THOROUGHLY CLEAN DOOR, FRAME AND HARDWARE. RE-CAULK DOOR FRAME. RE: ABATEMENT DRAWINGS.
9	REMOVE EXISTING PAINT ON DOOR AND DOOR FRAME. PREP DOOR AND DOOR FRAME TO RECEIVE NEW PAINT. RE: ABATEMENT DRAWINGS.
10	CAREFULLY REMOVE DOOR, FRAME AND HARDWARE. PREP OPENING FOR NEW DOOR. RE: ABATEMENT DRAWINGS.
11	REMOVE TOILET PARTITIONS. PATCH AND PREP WALL FOR NEW PAINT.
12	REMOVE ALL EXISTING RESTROOM ACCESSORIES. (INCLUDING BUT NOT LIMITED TO MIRROR, TOILET PAPER HOLDER, GRAB BARS, SOAP DISPENSER, PAPER TOWEL DISPENSER, TOILET CLEANER)
13	CAREFULLY REMOVE EXISTING TILE ON WALLS. PATCH AND PREP WALL TO RECEIVE NEW TILE.
14	MAINTAIN AND PROTECT FIRE ALARM AND ALL RELATED CONDUIT.
15	CONTRACTOR TO ENSURE CEILING IS A FINISH LEVEL OF 4. REMOVE ANY FLAKING PAINT. SAND CEILING FOR SMOOTH SURFACE AND PREP FOR NEW PAINT.
16	REMOVE EXISTING RADIATOR AND ALL ACCESSORIES ASSOCIATED WITH IT. PATCH AND PREP WALL.
17	PATCH HOLE IN THE WALL. PREP SURFACE TO RECEIVE NEW TILE.
18	REMOVE EXISTING LOCKERS.
19	REMOVE CONCRETE CURB. PROTECT SURROUNDING CONCRETE.
20	REMOVE EXISTING BENCH. PATCH AND PREP CONCRETE TO RECEIVE NEW SEAL.
21	REMOVE CEILING TILE AND GRID. PATCH AND PREP WALL TO RECEIVE NEW CEILING.
22	CAREFULLY REMOVE AND SALVAGE SUPPLY VENT FOR REUSE. REMOVE ANY PAINT FROM SURFACE AND CLEAN THOROUGHLY.
23	CAREFULLY REMOVE AND SALVAGE RETURN VENT FOR REUSE. REMOVE ANY PAINT FROM SURFACE AND CLEAN THOROUGHLY.
24	CAREFULLY REMOVE AND SALVAGE EXHAUST FAN FOR REUSE. REMOVE ANY PAINT FROM SURFACE AND CLEAN THOROUGHLY.
25	CAREFULLY REMOVE SURFACE MOUNTED LIGHT FIXTURE. ELECTRICAL TO REMAIN FOR REUSE.
26	REMOVE ALL LIGHT FIXTURES FROM ENTIRE ROOM. ELECTRICAL TO REMAIN FOR REUSE. CAP ANY ELECTRICAL NOT REUSED.
27	CAREFULLY REMOVE HANGING LIGHT FIXTURE. ELECTRICAL TO REMAIN FOR REUSE.
28	PREP PLASTER CEILING TO RECEIVE NEW PAINT.
29	PREP METAL CEILING TO RECEIVE NEW PAINT.
30	REMOVE DOOR, FRAME AND HARDWARE. PREPARE OPENING TO BE INFILLED.
31	REMOVE PORTION OF EXISTING WALL TO RECEIVE NEW DOOR.
A	MAIN STAGING AREA FOR CONTRACTOR
B	SUB-STAGING / PARKING AREA
C	STAGING AREAS SHALL BE REGRADED AND SEEDED WHEN THE CONSTRUCTION PROJECT HAS BEEN COMPLETED.
D	STAGING AREAS MUST BE FENCED AND LOCKABLE ALL TIMES.

ARCHITECT

**DOMAIN ARCHITECTURE**  
APAC

baton rouge, la 70806  
8316 kelwood avenue  
t: 225.216.3770 f: 225.216.3771  
www.domain-arch.com

REGISTRATION

These drawings are the property of DOMAIN ARCHITECTURE APAC and are not to be reproduced in whole or in part. They are only to be used for the project and site specifically identified herein. Scales stated herein are valid on the original drawings only. Contractor shall carefully review all dimensions and conditions shown and report to the architect any errors, inconsistencies, or omissions discovered. These plans were prepared in the office under our personal supervision, and to the best of our knowledge comply with state and local codes. We will generally administer construction.

CLIENT

**1** 1ST FLOOR STAFF - DEMOLITION FLOOR PLAN  
1/4" = 1'-0" DRAWN BY: KAS

**2** 1ST FLOOR STAFF - NEW CONSTRUCTION FLOOR PLAN  
1/4" = 1'-0" DRAWN BY: KAS

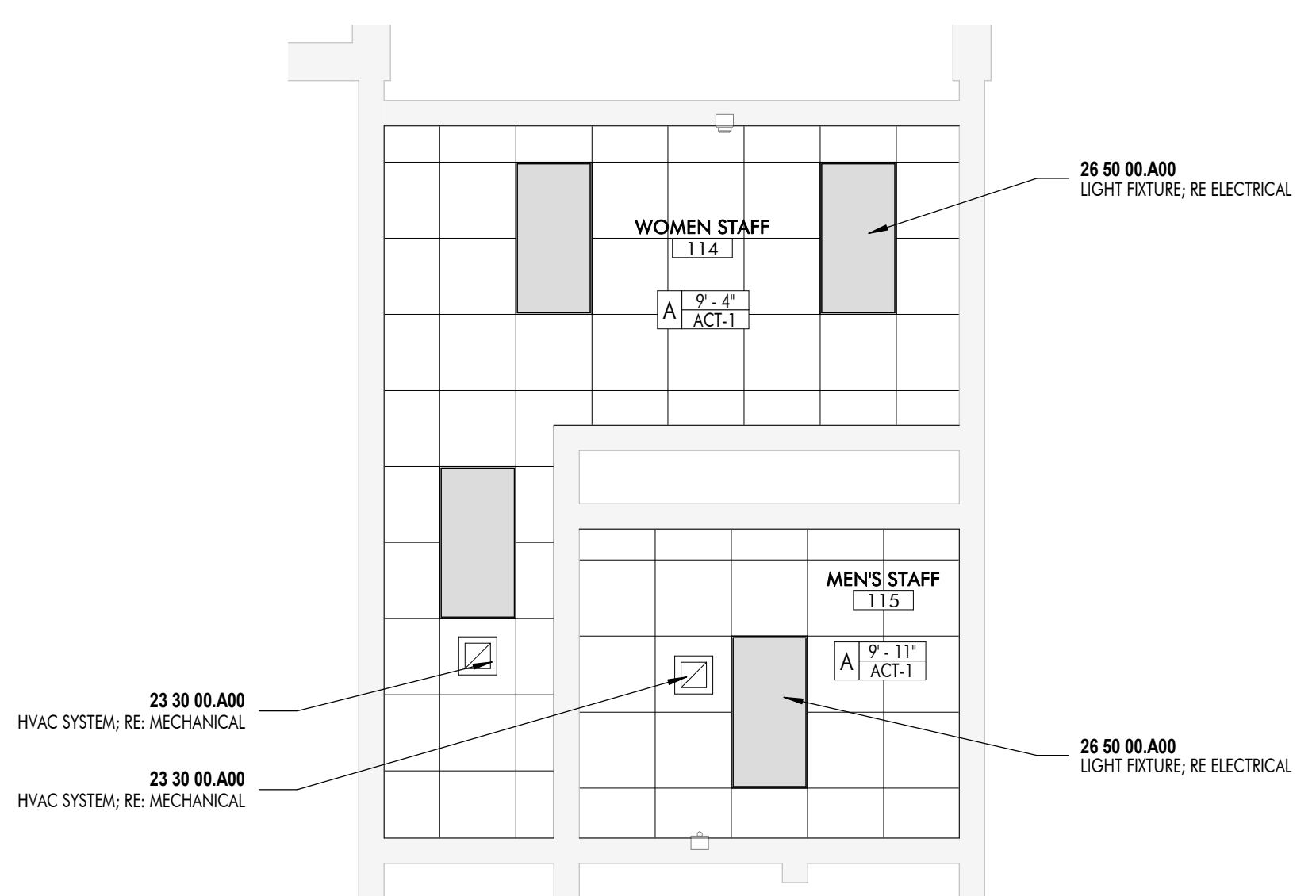
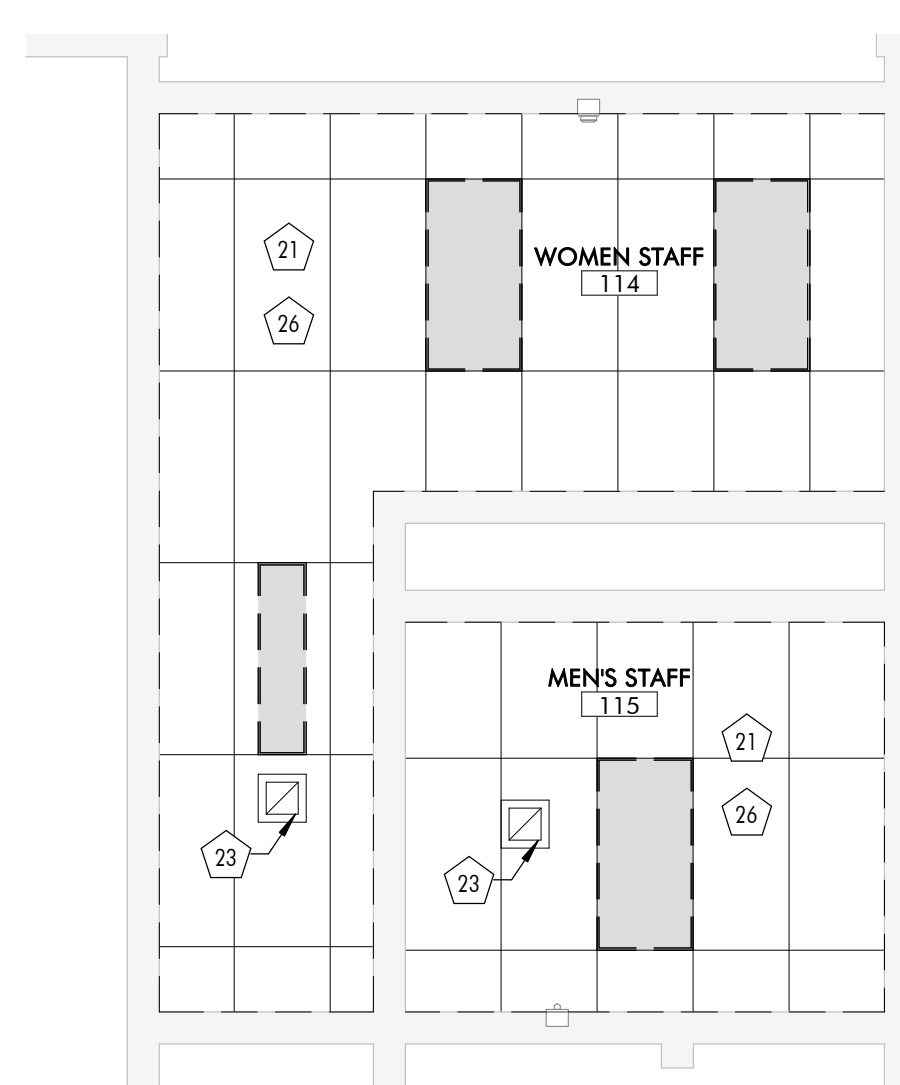

**3** 1ST FLOOR STAFF - DEMOLITION RCP  
1/4" = 1'-0" DRAWN BY: KAS

**4** 1ST FLOOR STAFF - NEW CONSTRUCTION RCP  
1/4" = 1'-0" DRAWN BY: KAS

Southern University Laboratory School

# RESTROOM RENOVATIONS

129 SWAN AVE,  
BATON ROUGE, LA 70813

PROJECT INFORMATION

revisions	No.	Description	Date

project # C22-0072  
date AUGUST 31, 2023  
director review

STAFF PLANS

# A9.05



These drawings are the property of DOMAIN ARCHITECTURE APC and are not to be reproduced in whole or in part. They are only to be used for the project and site specifically identified herein. Scales stated hereon are valid on the original drawing only. Contractor shall carefully review all dimensions and conditions shown and report to the architect any errors, inconsistencies, or omissions discovered. These plans were prepared in this office under our personal supervision, and to the best of our knowledge comply with state and local codes. We will generally administer construction.

CLIENT

Southern University Laboratory School  
**RESTROOM RENOVATIONS**

129 SWAN AVE,  
 BATON ROUGE, LA 70813

revisions	No.	Description	Date

project # **C22-0072**

date **AUGUST 31, 2023**

director review

STAFF ELEVATIONS

**A9.06**

AUGUST 31, 2023

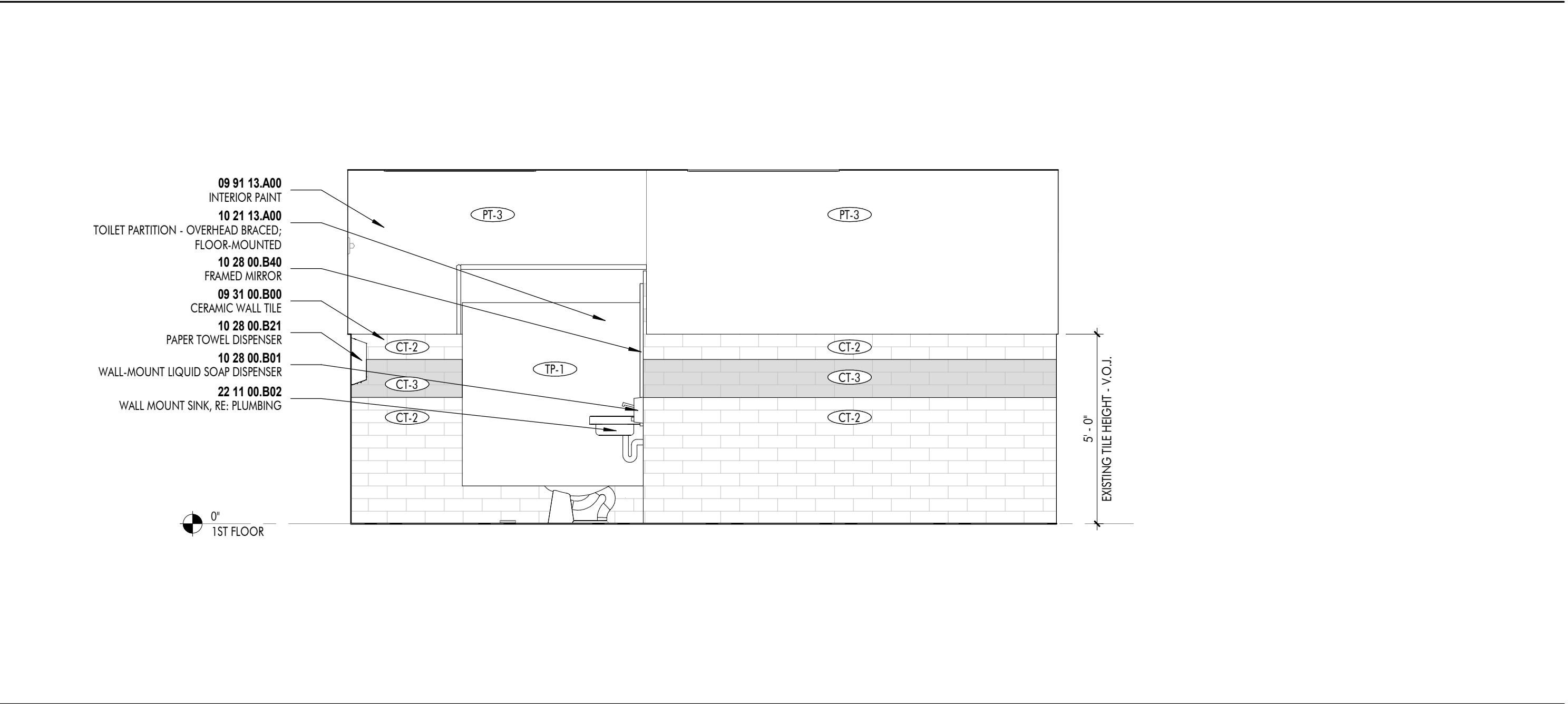
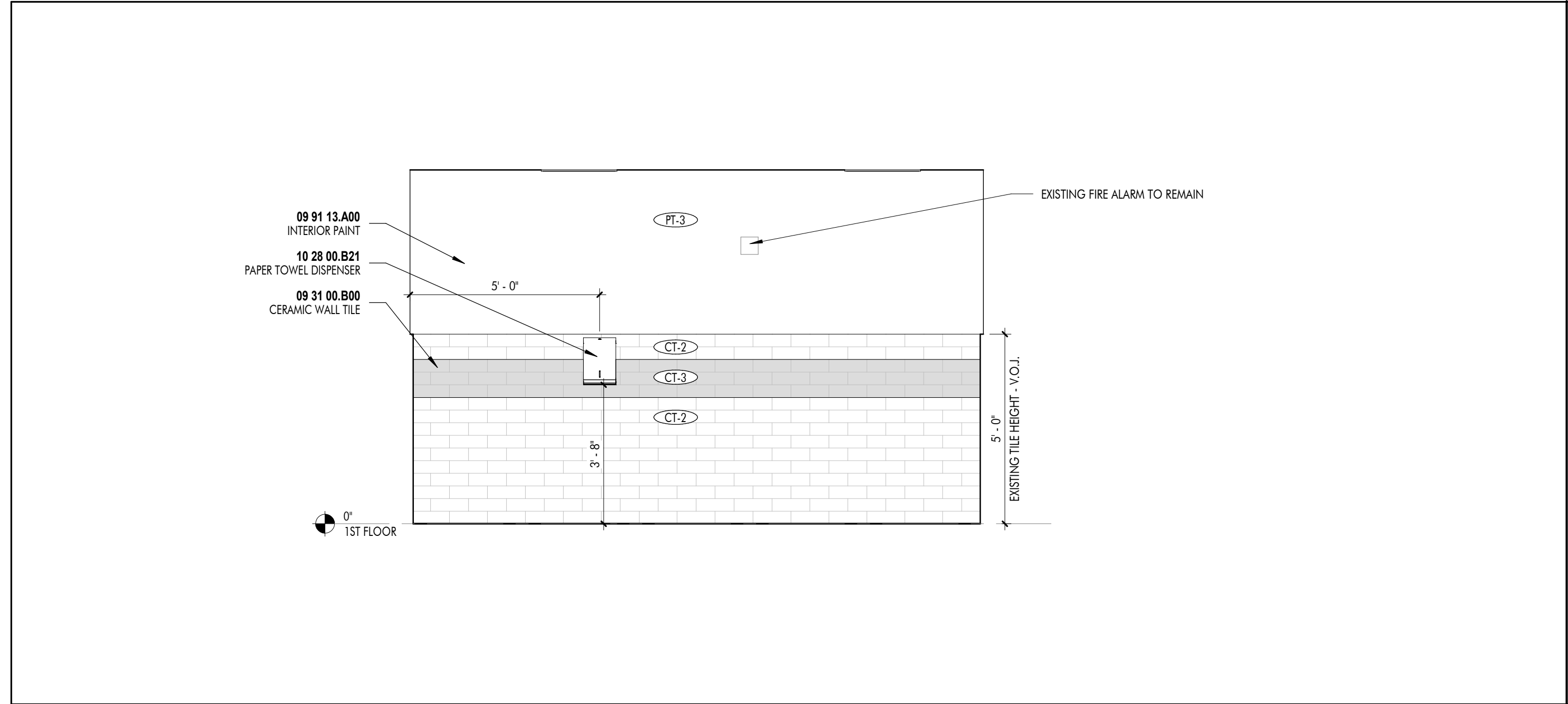

**1** STAFF WOMEN - NORTH  
 3/8" = 1'-0" DRAWN BY: KAS

**2** STAFF WOMEN - EAST  
 3/8" = 1'-0" DRAWN BY: KAS

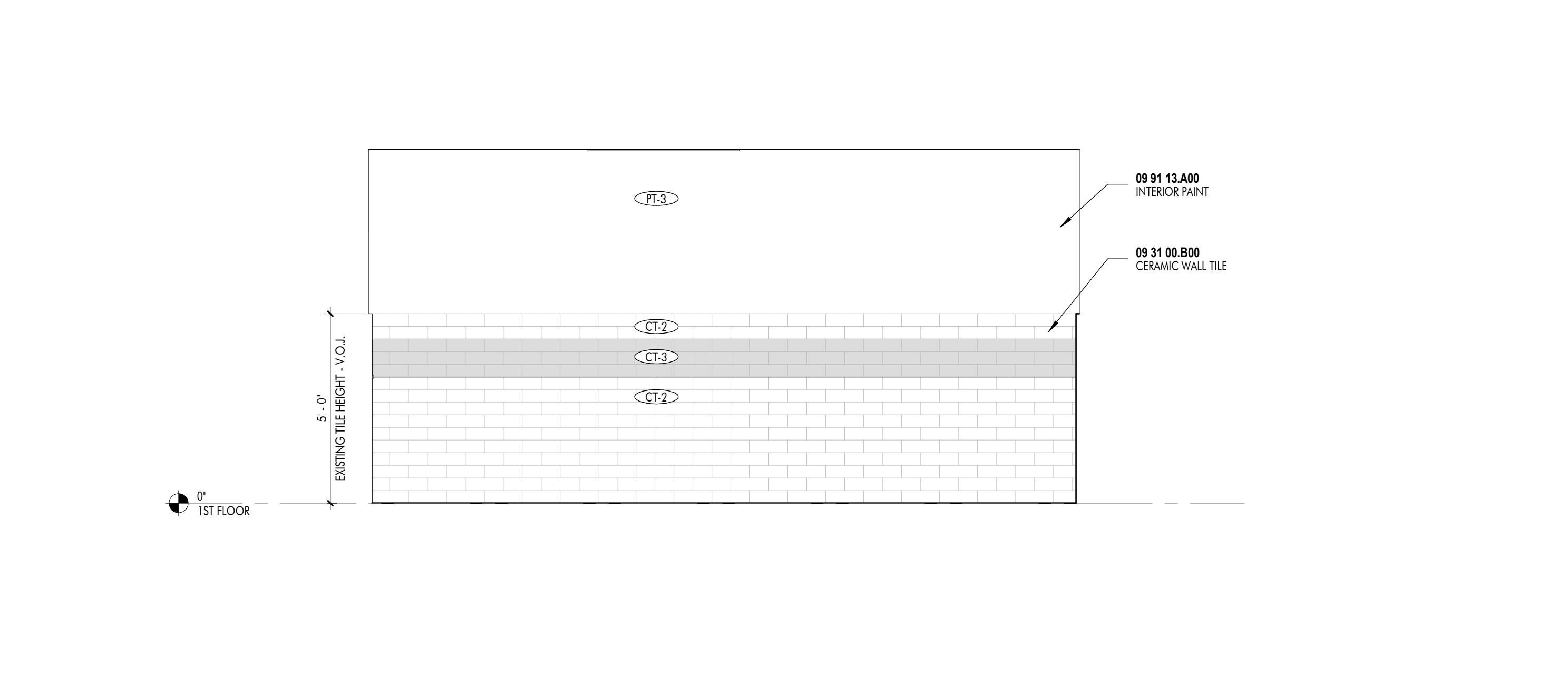
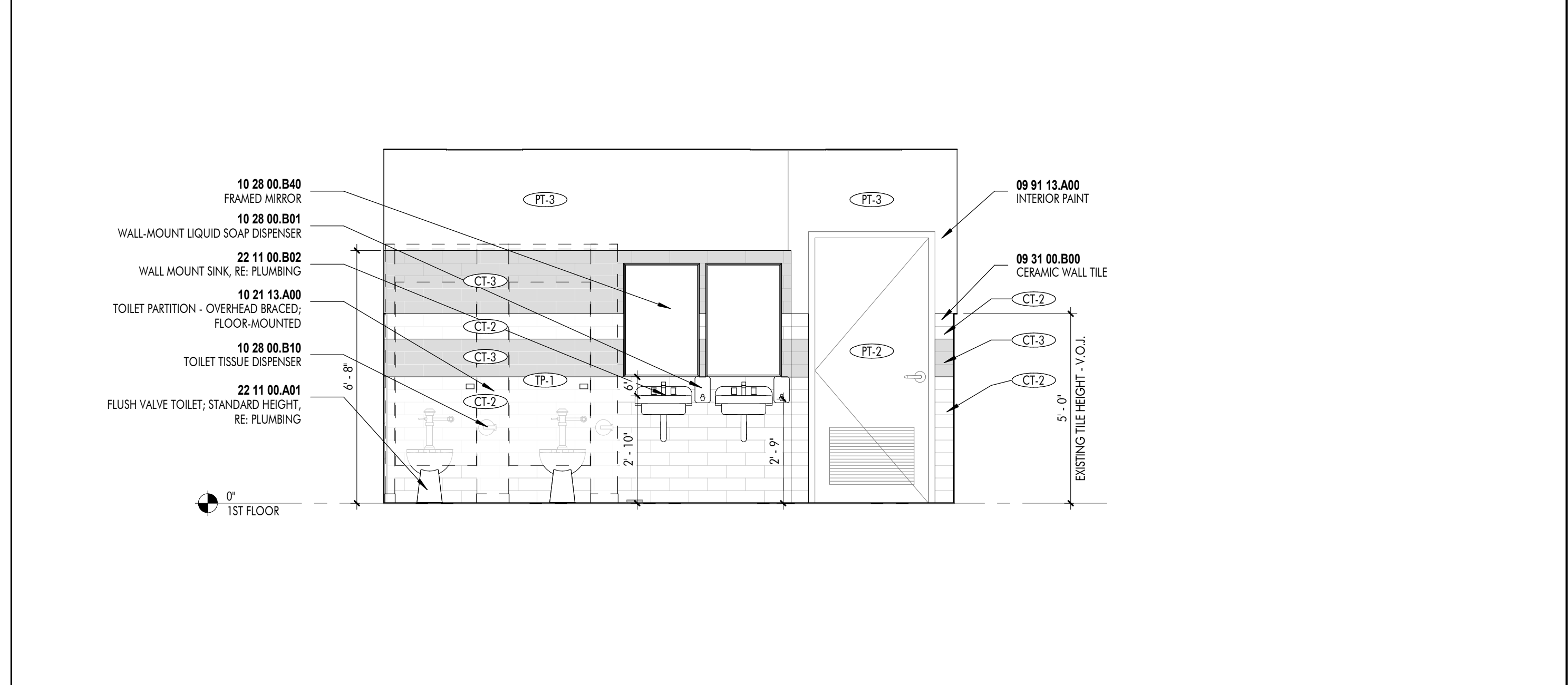

**3** STAFF WOMEN - SOUTH  
 3/8" = 1'-0" DRAWN BY: KAS

**4** STAFF WOMEN - WEST  
 3/8" = 1'-0" DRAWN BY: KAS

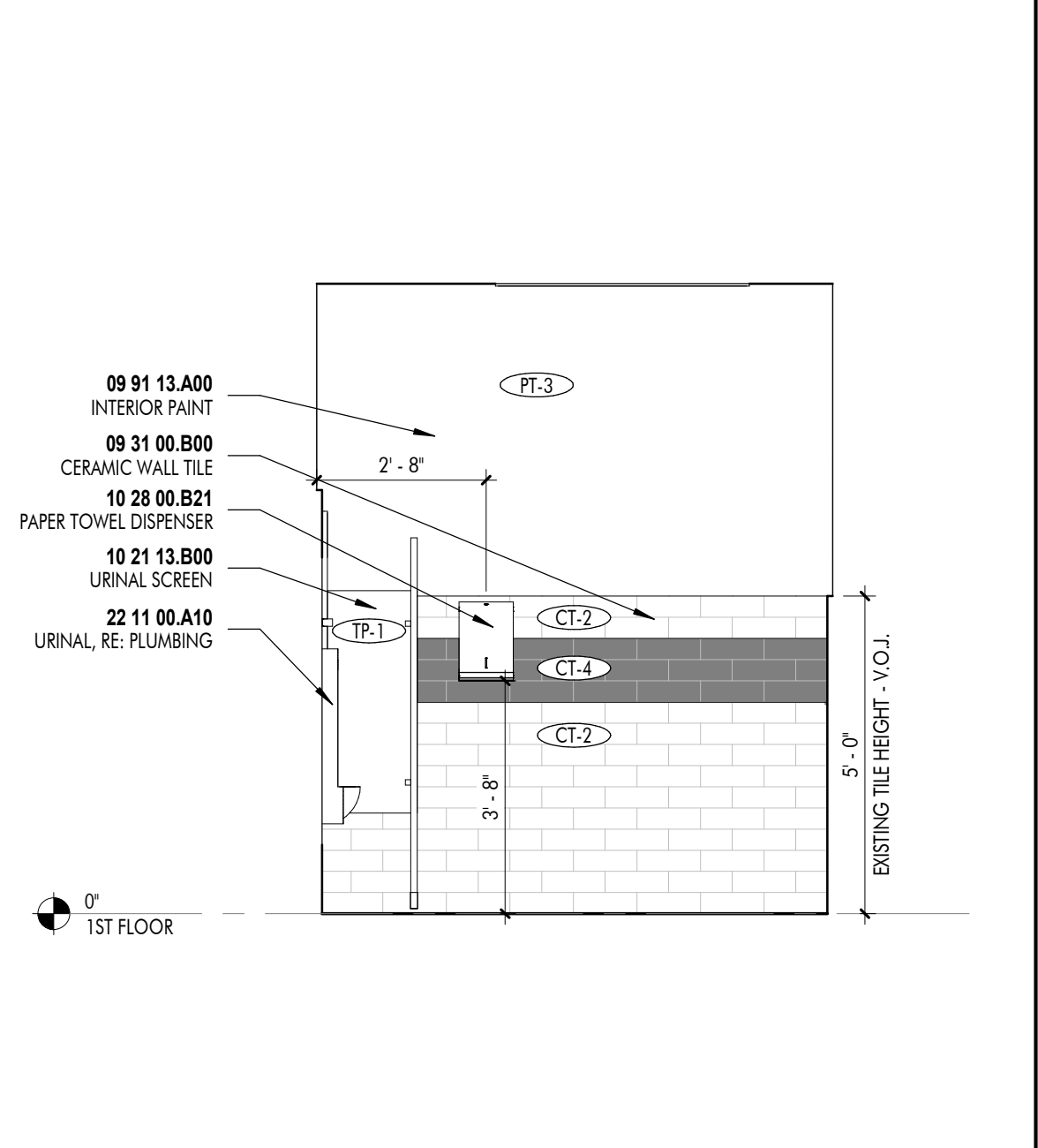
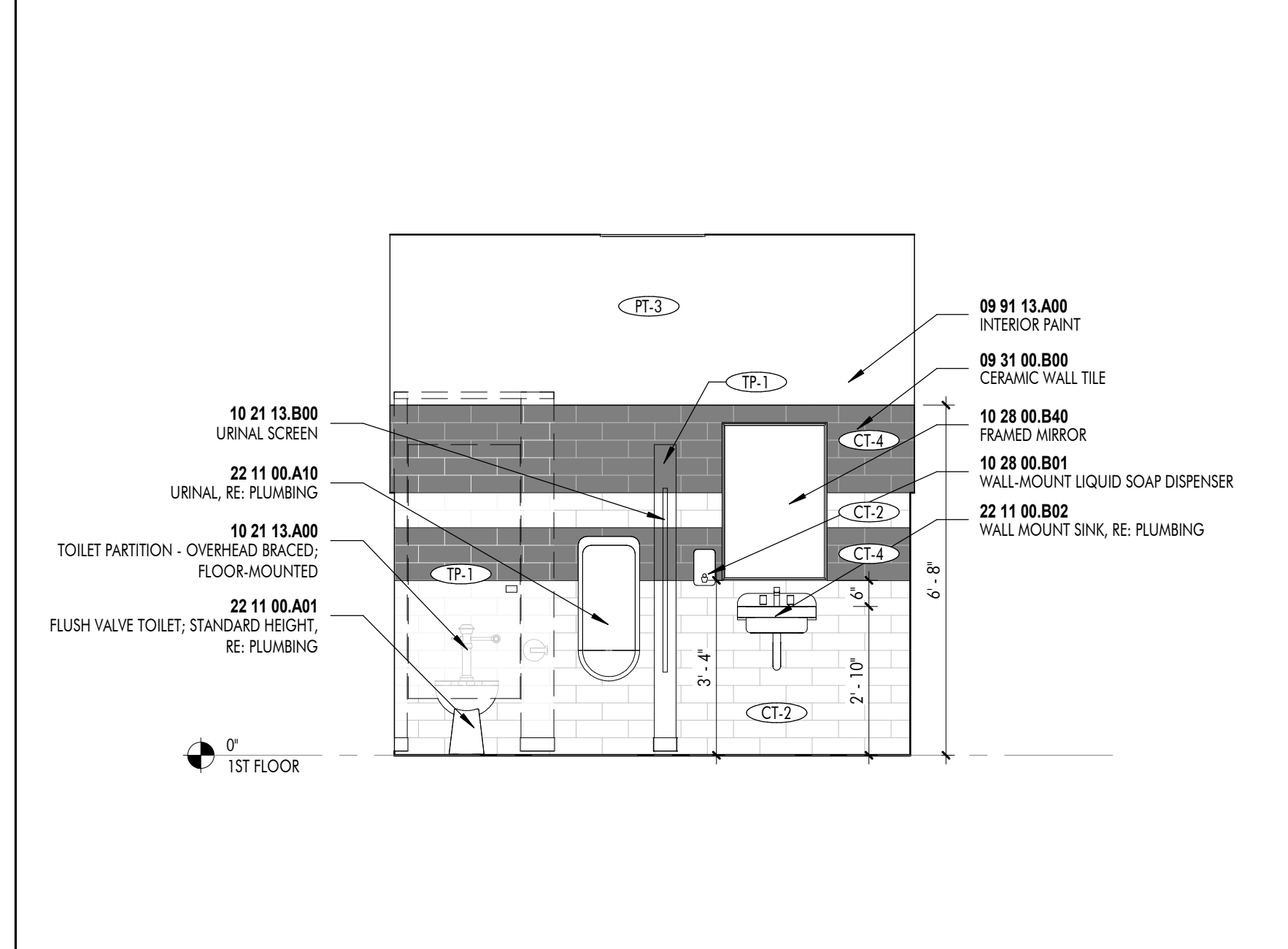

**5** STAFF MEN - NORTH  
 3/8" = 1'-0" DRAWN BY: KAS

**6** STAFF MEN - EAST  
 3/8" = 1'-0" DRAWN BY: KAS

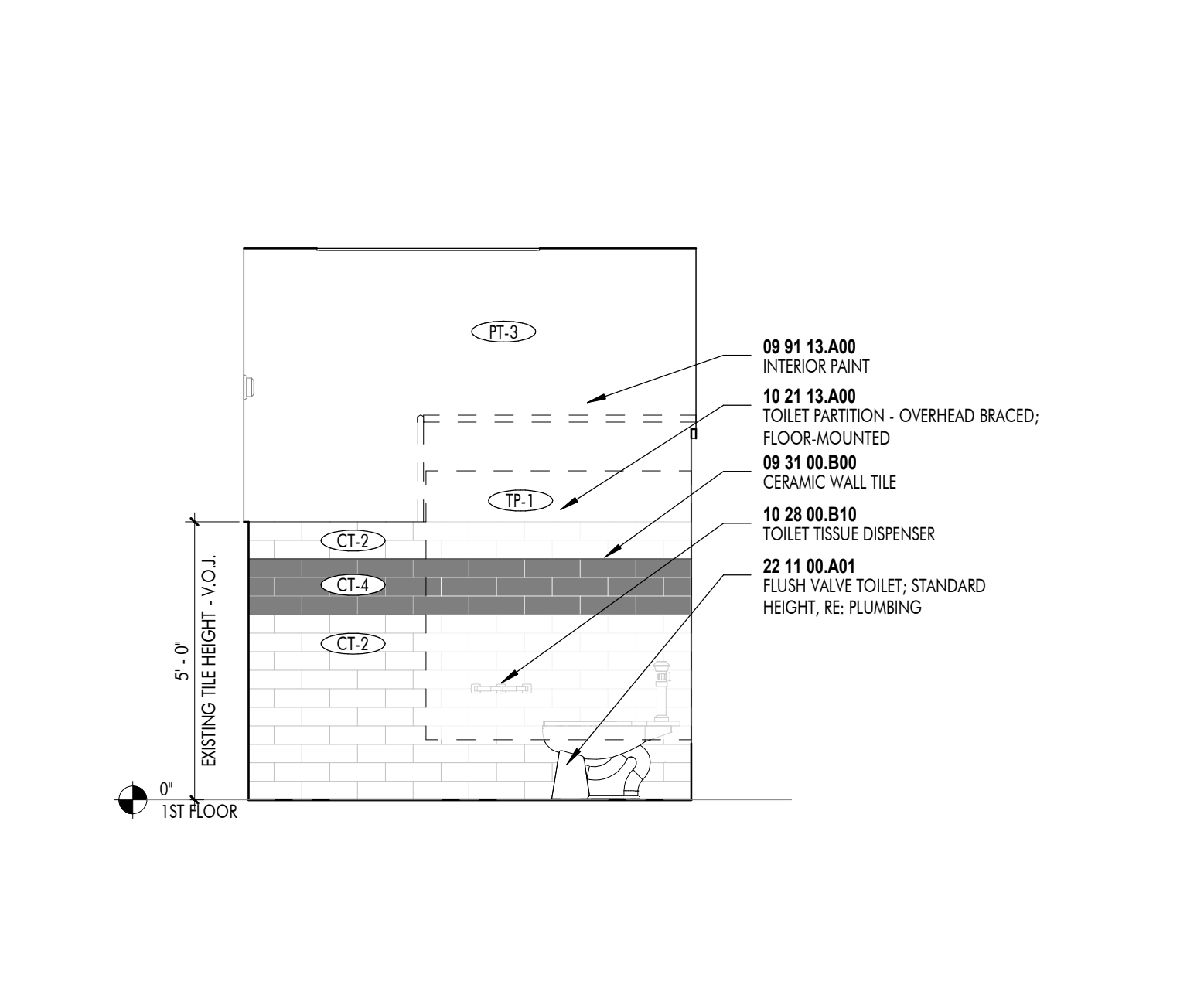
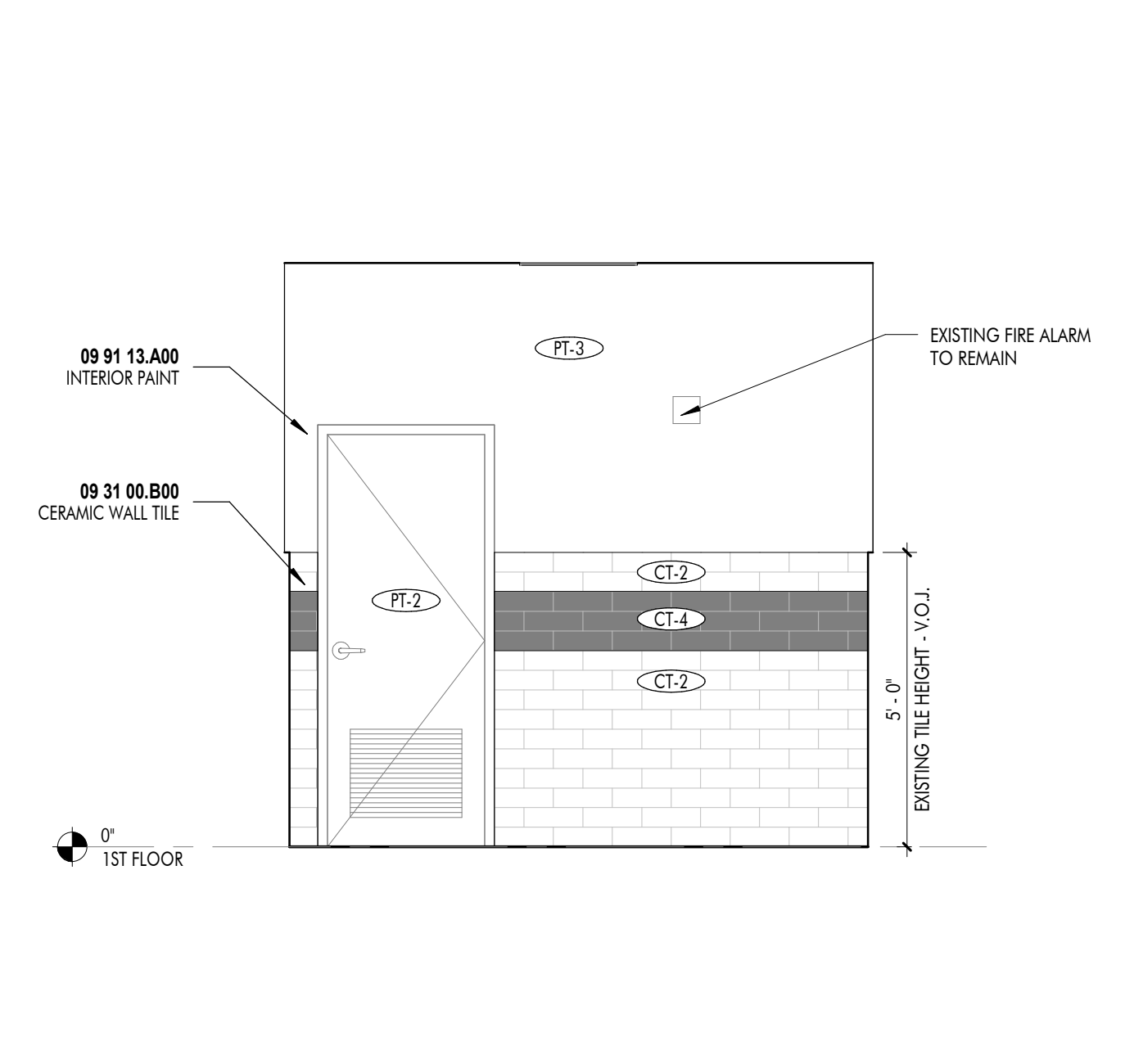

**7** STAFF MEN SOUTH  
 3/8" = 1'-0" DRAWN BY: KAS

**8** STAFF MEN - WEST  
 3/8" = 1'-0" DRAWN BY: KAS

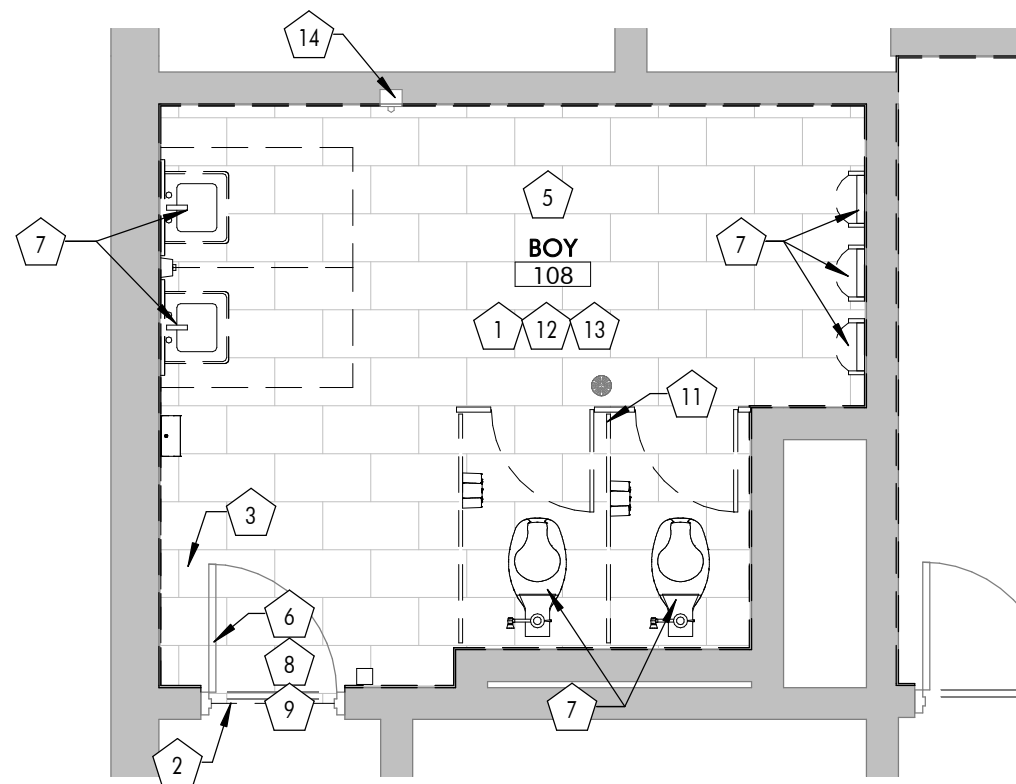

**1** 1ST FLOOR BOYS - DEMOLITION FLOOR PLAN  
1/4" = 1'-0" DRAWN BY: KAS

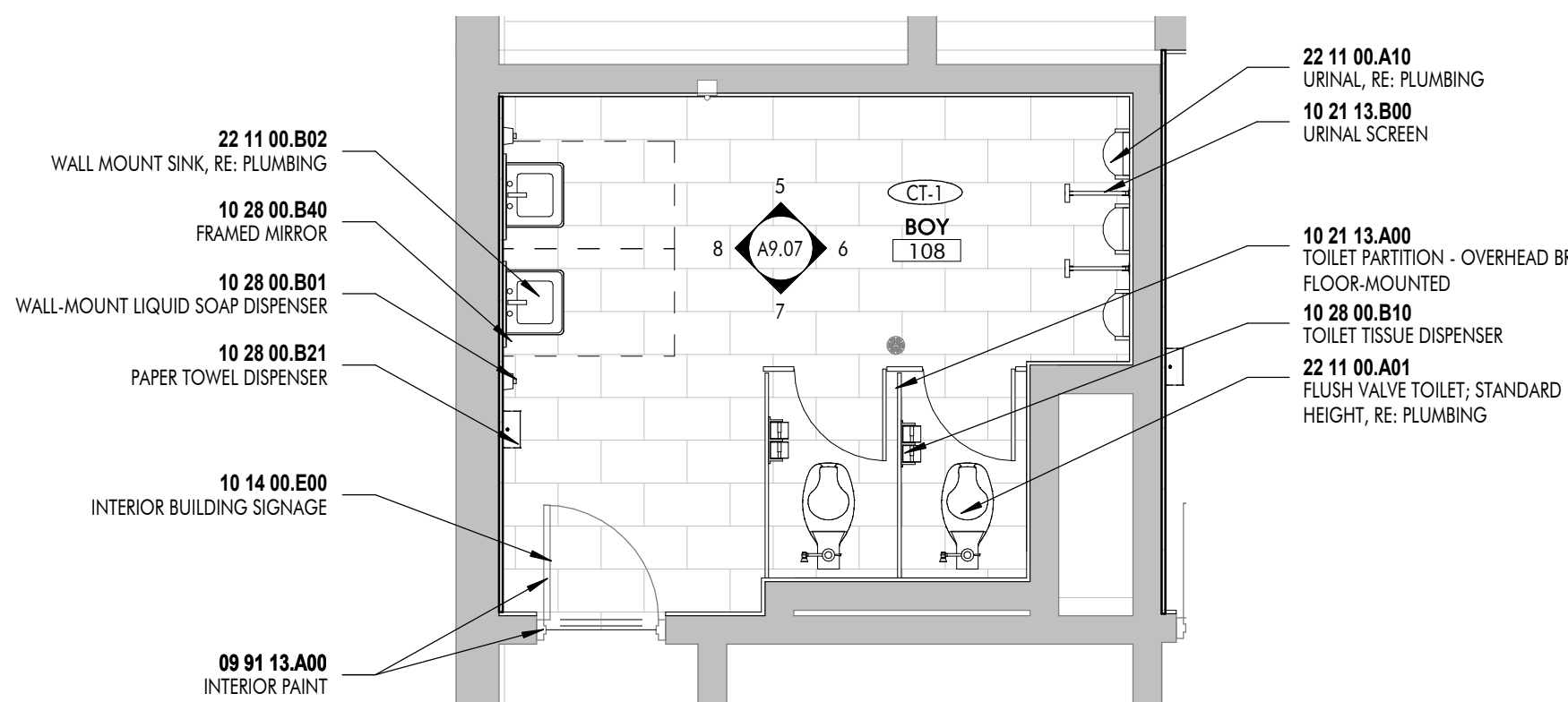

**2** 1ST FLOOR BOYS - NEW CONSTRUCTION FLOOR PLAN  
1/4" = 1'-0" DRAWN BY: KAS

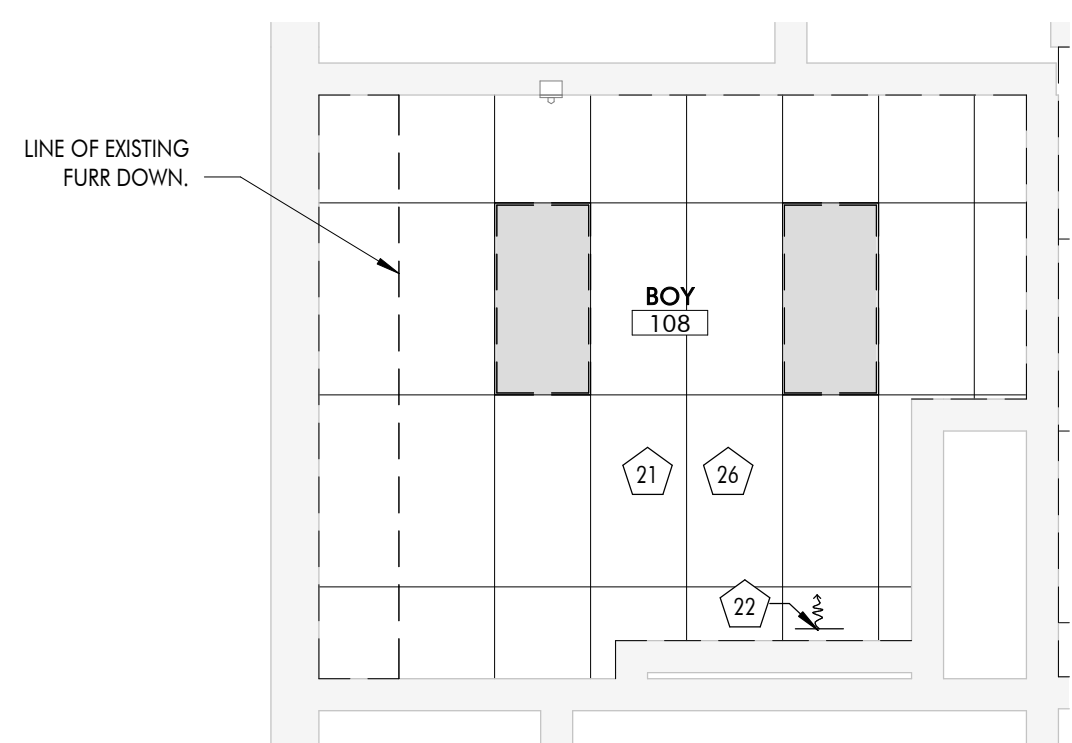

**3** 1ST FLOOR BOYS - DEMOLITION RCP  
1/4" = 1'-0" DRAWN BY: KAS

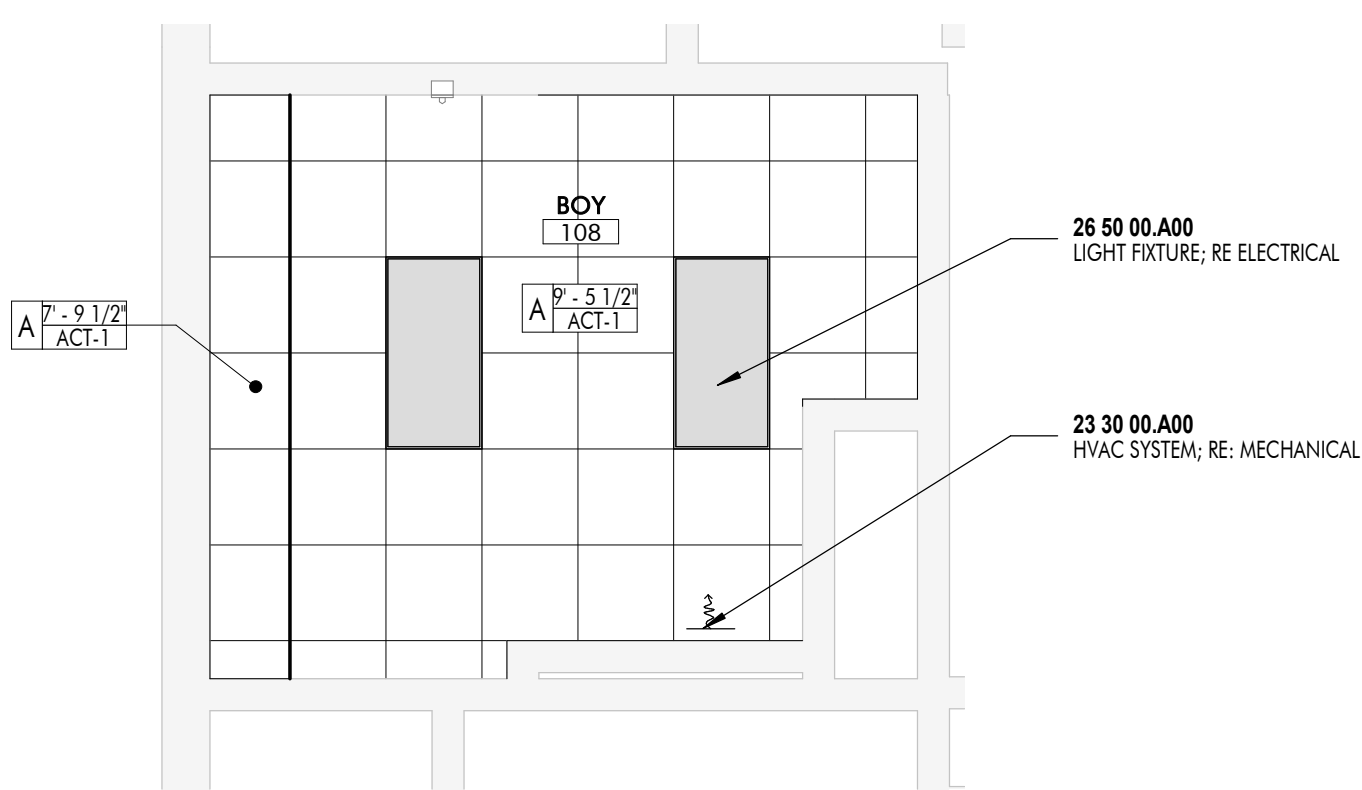

**4** 1ST FLOOR BOYS - NEW CONSTRUCTION RCP  
1/4" = 1'-0" DRAWN BY: KAS

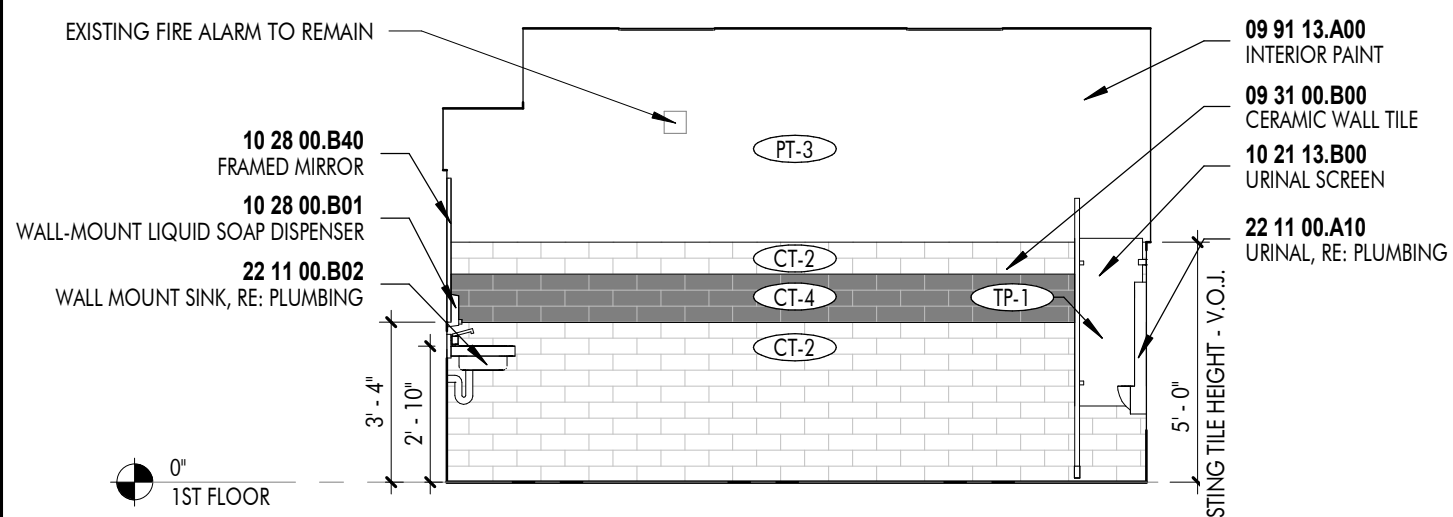

**5** 1ST FLOOR BOYS - NORTH  
1/4" = 1'-0" DRAWN BY: KAS

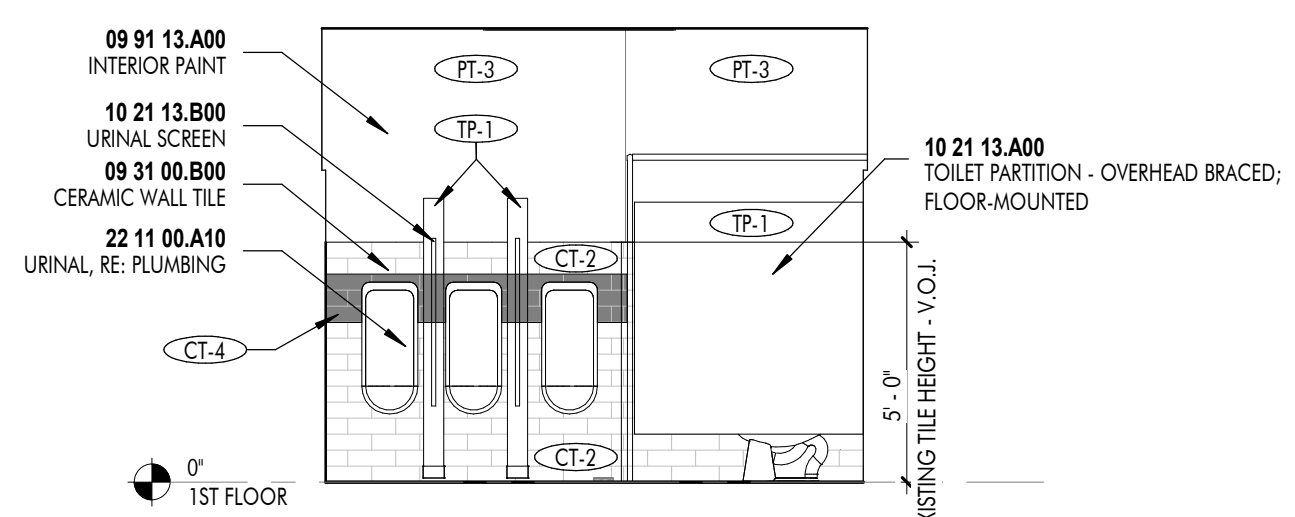

**6** 1ST FLOOR BOYS - EAST  
1/4" = 1'-0" DRAWN BY: KAS

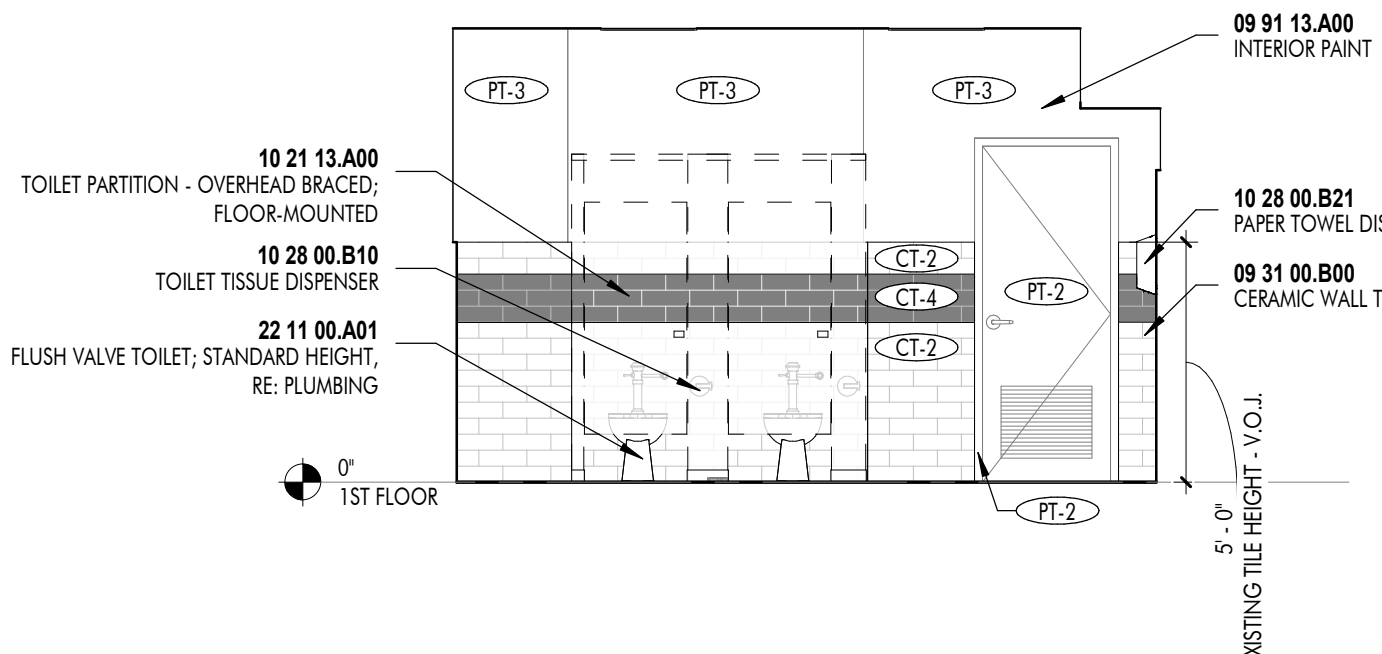

**7** 1ST FLOOR BOYS - SOUTH  
1/4" = 1'-0" DRAWN BY: KAS

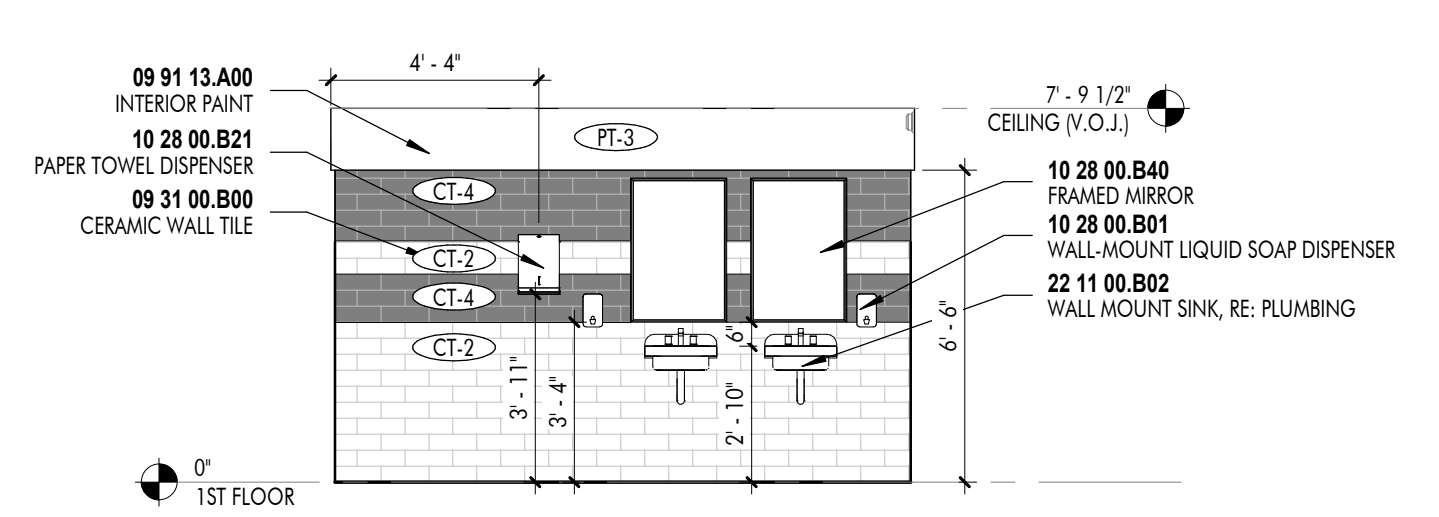

**8** 1ST FLOOR BOYS - WEST  
1/4" = 1'-0" DRAWN BY: KAS

CONSTRUCTION NOTES	
MARK	DESCRIPTION
1	REMOVE EXISTING FLOOR TILE. PATCH AND PREP FLOOR TO RECEIVE NEW TILE AS SCHEDULED. PROVIDE LEVELING COMPOUND AS NECESSARY. MOISTURE TEST EXISTING FLOOR BEFORE NEW FLOOR IS INSTALLED. THOROUGHLY CLEAN EXISTING FLOOR DRAIN.
2	MARBLE THRESHOLD TO BE PROTECTED FOR DURATION OF CONSTRUCTION. THRESHOLD TO BE CLEANED AT END OF CONSTRUCTION.
3	REMOVE DOORSTOP. PATCH AND PREP FLOOR TO RECEIVE NEW DOORSTOP.
4	REMOVE PAINT AND RUST FROM EXISTING STOREFRONT. PREP SURFACE TO RECEIVE NEW PAINT.
5	CONTRACTOR TO ENSURE WALL IS A FINISH LEVEL OF 4. REMOVE ANY FLAKING PAINT. SAND WALL FOR SMOOTH SURFACE AND PREP FOR NEW PAINT.
6	CAREFULLY REMOVE ANY EXISTING INTERIOR SIGNAGE. PATCH AND PREP WALL FOR NEW PAINT.
7	REMOVE EXISTING PLUMBING FIXTURE. MAINTAIN EXISTING PLUMBING FOR REUSE.
8	THOROUGHLY CLEAN DOOR, FRAME AND HARDWARE. RE-CAULK DOOR FRAME. RE: ABATEMENT DRAWINGS.
9	REMOVE EXISTING PAINT ON DOOR AND DOOR FRAME. PREP DOOR AND DOOR FRAME TO RECEIVE NEW PAINT. RE: ABATEMENT DRAWINGS.
10	CAREFULLY REMOVE DOOR, FRAME AND HARDWARE. PREP OPENING FOR NEW DOOR. RE: ABATEMENT DRAWINGS.
11	REMOVE TOILET PARTITIONS. PATCH AND PREP WALL FOR NEW PAINT.
12	REMOVE ALL EXISTING RESTROOM ACCESSORIES. (INCLUDING BUT NOT LIMITED TO MIRROR, TOILET PAPER HOLDER, GRAB BARS, SOAP DISPENSER, PAPER TOWEL DISPENSER, TOILET CLEANER)
13	CAREFULLY REMOVE EXISTING TILE ON WALLS. PATCH AND PREP WALL TO RECEIVE NEW TILE.
14	MAINTAIN AND PROTECT FIRE ALARM AND ALL RELATED CONDUIT.
15	CONTRACTOR TO ENSURE CEILING IS A FINISH LEVEL OF 4. REMOVE ANY FLAKING PAINT. SAND CEILING FOR SMOOTH SURFACE AND PREP FOR NEW PAINT.
16	REMOVE EXISTING RADIATOR AND ALL ACCESSORIES ASSOCIATED WITH IT. PATCH AND PREP WALL.
17	PATCH HOLE IN THE WALL. PREP SURFACE TO RECEIVE NEW TILE.
18	REMOVE EXISTING LOCKERS.
19	REMOVE CONCRETE CURB. PROTECT SURROUNDING CONCRETE.
20	REMOVE EXISTING BENCH. PATCH AND PREP CONCRETE TO RECEIVE NEW SEAL.
21	REMOVE CEILING TILE AND GRID. PATCH AND PREP WALL TO RECEIVE NEW CEILING.
22	CAREFULLY REMOVE AND SALVAGE SUPPLY VENT FOR REUSE. REMOVE ANY PAINT FROM SURFACE AND CLEAN THOROUGHLY.
23	CAREFULLY REMOVE AND SALVAGE RETURN VENT FOR REUSE. REMOVE ANY PAINT FROM SURFACE AND CLEAN THOROUGHLY.
24	CAREFULLY REMOVE AND SALVAGE EXHAUST FAN FOR REUSE. REMOVE ANY PAINT FROM SURFACE AND CLEAN THOROUGHLY.
25	CAREFULLY REMOVE SURFACE MOUNTED LIGHT FIXTURE. ELECTRICAL TO REMAIN FOR REUSE.
26	REMOVE ALL LIGHT FIXTURES FROM ENTIRE ROOM. ELECTRICAL TO REMAIN FOR REUSE. CAP ANY ELECTRICAL NOT REUSED.
27	CAREFULLY REMOVE HANGING LIGHT FIXTURE. ELECTRICAL TO REMAIN FOR REUSE.
28	PREP PLASTER CEILING TO RECEIVE NEW PAINT.
29	PREP METAL CEILING TO RECEIVE NEW PAINT.
30	REMOVE DOOR, FRAME AND HARDWARE. PREPARE OPENING TO BE INFILLED.
31	REMOVE PORTION OF EXISTING WALL TO RECEIVE NEW DOOR.
A	MAIN STAGING AREA FOR CONTRACTOR
B	SUB-STAGING / PARKING AREA
C	STAGING AREAS SHALL BE REGRADED AND SEEDED WHEN THE CONSTRUCTION PROJECT HAS BEEN COMPLETED.
D	STAGING AREAS MUST BE FENCED AND LOCKABLE ALL TIMES.



These drawings are the property of DOMAIN ARCHITECTURE APC and are not to be reproduced in whole or in part. They are only to be used for the project and site specifically identified herein. Scales stated thereon are valid on the original drawings only. Contractor shall carefully review all dimensions and conditions shown and report to the architect any errors, inconsistencies, or omissions discovered. These plans were prepared in the office under our personal supervision, and to the best of our knowledge comply with state and local codes. We will generally administer construction.

CLIENT

Southern University Laboratory School  
**RESTROOM RENOVATIONS**

129 SWAN AVE,  
BATON ROUGE, LA 70813

PROJECT INFORMATION	
No.	Description

project # C22-0072  
date AUGUST 31, 2023  
director review

BOYS

A9.07

AUGUST 31, 2023



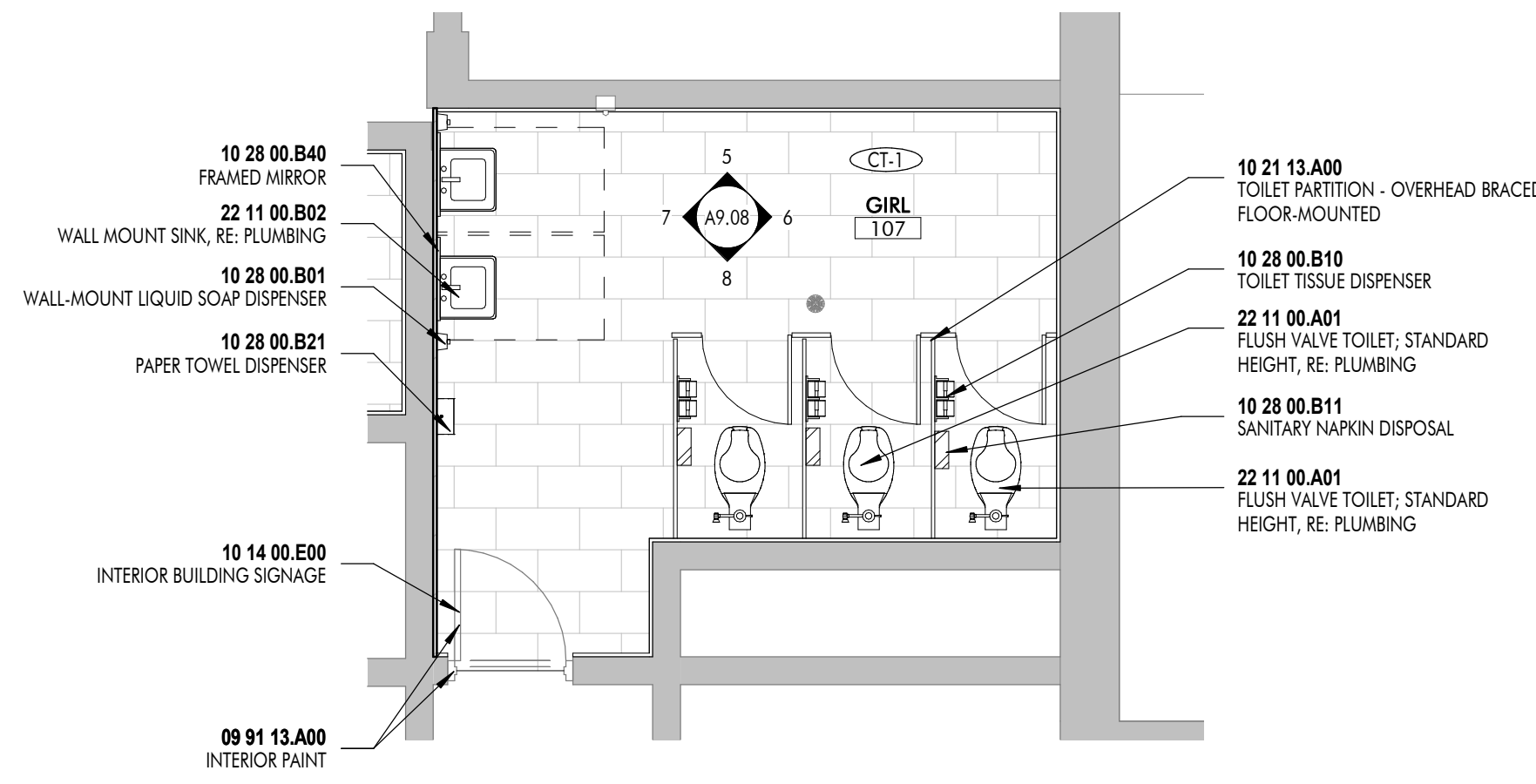
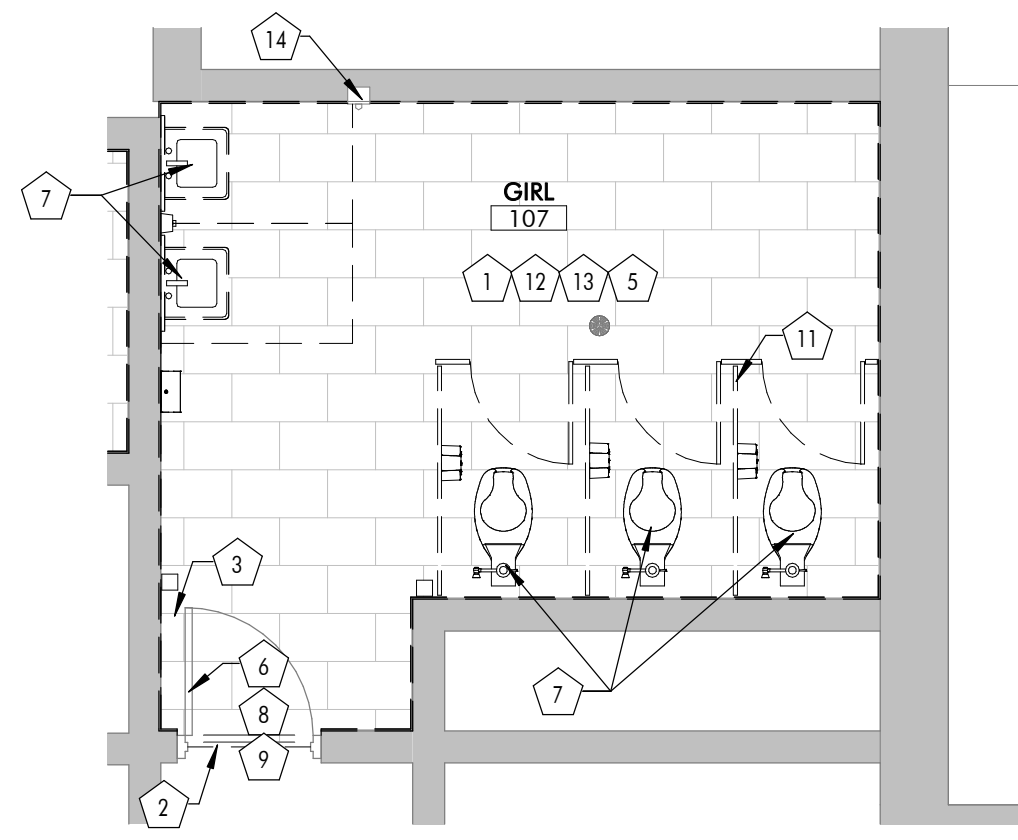

**CONSTRUCTION NOTES**

MARK	DESCRIPTION
1	REMOVE EXISTING FLOOR TILE. PATCH AND PREP FLOOR TO RECEIVE NEW TILE AS SCHEDULED. PROVIDE LEVELING COMPOUND AS NECESSARY. MOISTURE TEST EXISTING FLOOR BEFORE NEW FLOOR IS INSTALLED. THOROUGHLY CLEAN EXISTING FLOOR DRAIN.
2	MARBLE THRESHOLD TO BE PROTECTED FOR DURATION OF CONSTRUCTION. THRESHOLD TO BE CLEANED AT END OF CONSTRUCTION.
3	REMOVE DOORSTOP. PATCH AND PREP FLOOR TO RECEIVE NEW DOORSTOP.
4	REMOVE PAINT AND RUST FROM EXISTING STOREFRONT. PREP SURFACE TO RECEIVE NEW PAINT.
5	CONTRACTOR TO ENSURE WALL IS A FINISH LEVEL OF 4. REMOVE ANY FLAKING PAINT. SAND WALL FOR SMOOTH SURFACE AND PREP FOR NEW PAINT.
6	CAREFULLY REMOVE ANY EXISTING INTERIOR SIGNAGE. PATCH AND PREP WALL FOR NEW PAINT.
7	REMOVE EXISTING PLUMBING FIXTURE. MAINTAIN EXISTING PLUMBING FOR REUSE.
8	THOROUGHLY CLEAN DOOR, FRAME AND HARDWARE. RE-CAULK DOOR FRAME. RE: ABATEMENT DRAWINGS.
9	REMOVE EXISTING PAINT ON DOOR AND DOOR FRAME. PREP DOOR AND DOOR FRAME TO RECEIVE NEW PAINT. RE: ABATEMENT DRAWINGS.
10	CAREFULLY REMOVE DOOR, FRAME AND HARDWARE. PREP OPENING FOR NEW DOOR. RE: ABATEMENT DRAWINGS.
11	REMOVE TOILET PARTITIONS. PATCH AND PREP WALL FOR NEW PAINT.
12	REMOVE ALL EXISTING RESTROOM ACCESSORIES, (INCLUDING BUT NOT LIMITED TO MIRROR, TOILET PAPER HOLDER, GRAB BARS, SOAP DISPENSER, PAPER TOWEL DISPENSER, TOILET CLEANER)
13	CAREFULLY REMOVE EXISTING TILE ON WALLS. PATCH AND PREP WALL TO RECEIVE NEW TILE.
14	MAINTAIN AND PROTECT FIRE ALARM AND ALL RELATED CONDUIT.
15	CONTRACTOR TO ENSURE CEILING IS A FINISH LEVEL OF 4. REMOVE ANY FLAKING PAINT. SAND CEILING FOR SMOOTH SURFACE AND PREP FOR NEW PAINT.
16	REMOVE EXISTING RADIATOR AND ALL ACCESSORIES ASSOCIATED WITH IT. PATCH AND PREP WALL.
17	PATCH HOLE IN THE WALL. PREP SURFACE TO RECEIVE NEW TILE.
18	REMOVE EXISTING LOCKERS.
19	REMOVE CONCRETE CURB. PROTECT SURROUNDING CONCRETE.
20	REMOVE EXISTING BENCH. PATCH AND PREP CONCRETE TO RECEIVE NEW SEAL.
21	REMOVE CEILING TILE AND GRID. PATCH AND PREP WALL TO RECEIVE NEW CEILING.
22	CAREFULLY REMOVE AND SALVAGE SUPPLY VENT FOR REUSE. REMOVE ANY PAINT FROM SURFACE AND CLEAN THOROUGHLY.
23	CAREFULLY REMOVE AND SALVAGE RETURN VENT FOR REUSE. REMOVE ANY PAINT FROM SURFACE AND CLEAN THOROUGHLY.
24	CAREFULLY REMOVE AND SALVAGE EXHAUST FAN FOR REUSE. REMOVE ANY PAINT FROM SURFACE AND CLEAN THOROUGHLY.
25	CAREFULLY REMOVE SURFACE MOUNTED LIGHT FIXTURE. ELECTRICAL TO REMAIN FOR REUSE.
26	REMOVE ALL LIGHT FIXTURES FROM ENTIRE ROOM. ELECTRICAL TO REMAIN FOR REUSE. CAP ANY ELECTRICAL NOT REUSED.
27	CAREFULLY REMOVE HANGING LIGHT FIXTURE. ELECTRICAL TO REMAIN FOR REUSE.
28	PREP PLASTER CEILING TO RECEIVE NEW PAINT.
29	PREP METAL CEILING TO RECEIVE NEW PAINT.
30	REMOVE DOOR, FRAME AND HARDWARE. PREP OPENING TO BE INFILLED.
31	REMOVE PORTION OF EXISTING WALL TO RECEIVE NEW DOOR.
A	MAIN STAGING AREA FOR CONTRACTOR
B	SUB-STAGING / PARKING AREA
C	STAGING AREAS SHALL BE REGRADED AND SEEDED WHEN THE CONSTRUCTION PROJECT HAS BEEN COMPLETED.
D	STAGING AREAS MUST BE FENCED AND LOCKABLE ALL TIMES.

**1** 1ST FLOOR GIRLS - DEMOLITION FLOOR PLAN  
1/4" = 1'-0" DRAWN BY: KAS

**2** 1ST FLOOR GIRLS - NEW CONSTRUCTION FLOOR PLAN  
1/4" = 1'-0" DRAWN BY: KAS

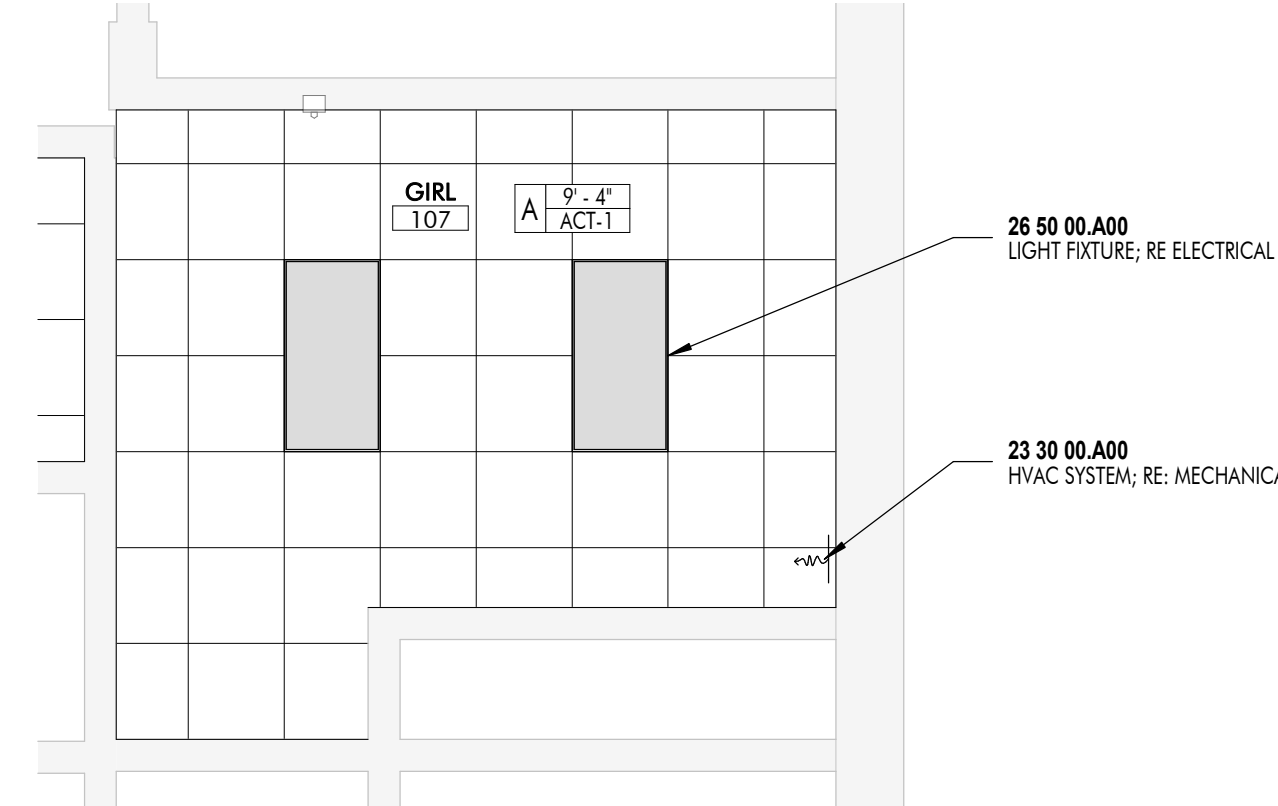
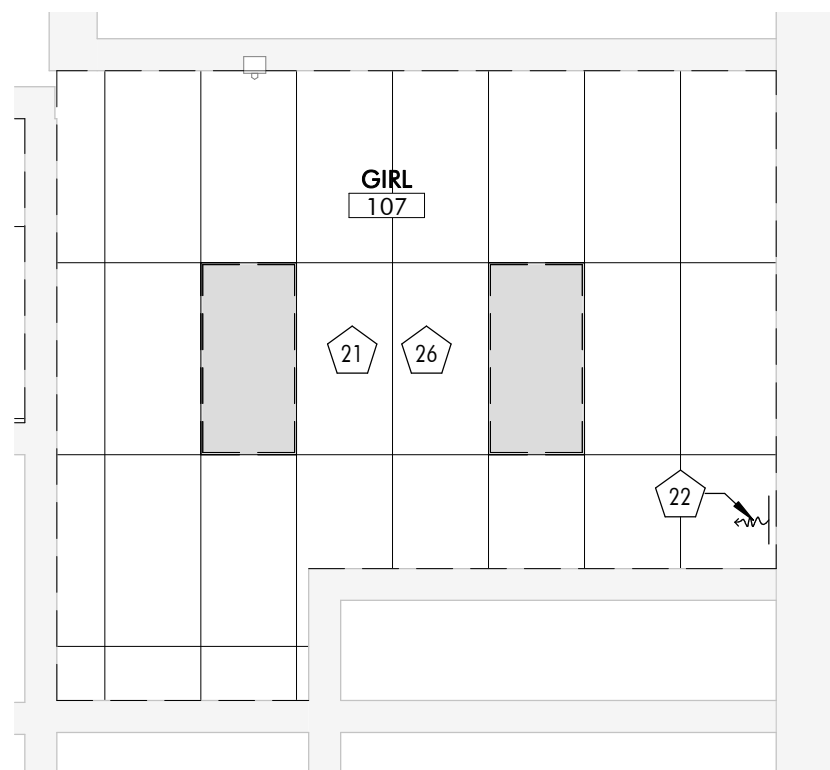

**3** 1ST FLOOR GIRLS - DEMOLITION RCPC  
1/4" = 1'-0" DRAWN BY: KAS

**4** 1ST FLOOR GIRLS - NEW CONSTRUCTION RCPC  
1/4" = 1'-0" DRAWN BY: KAS

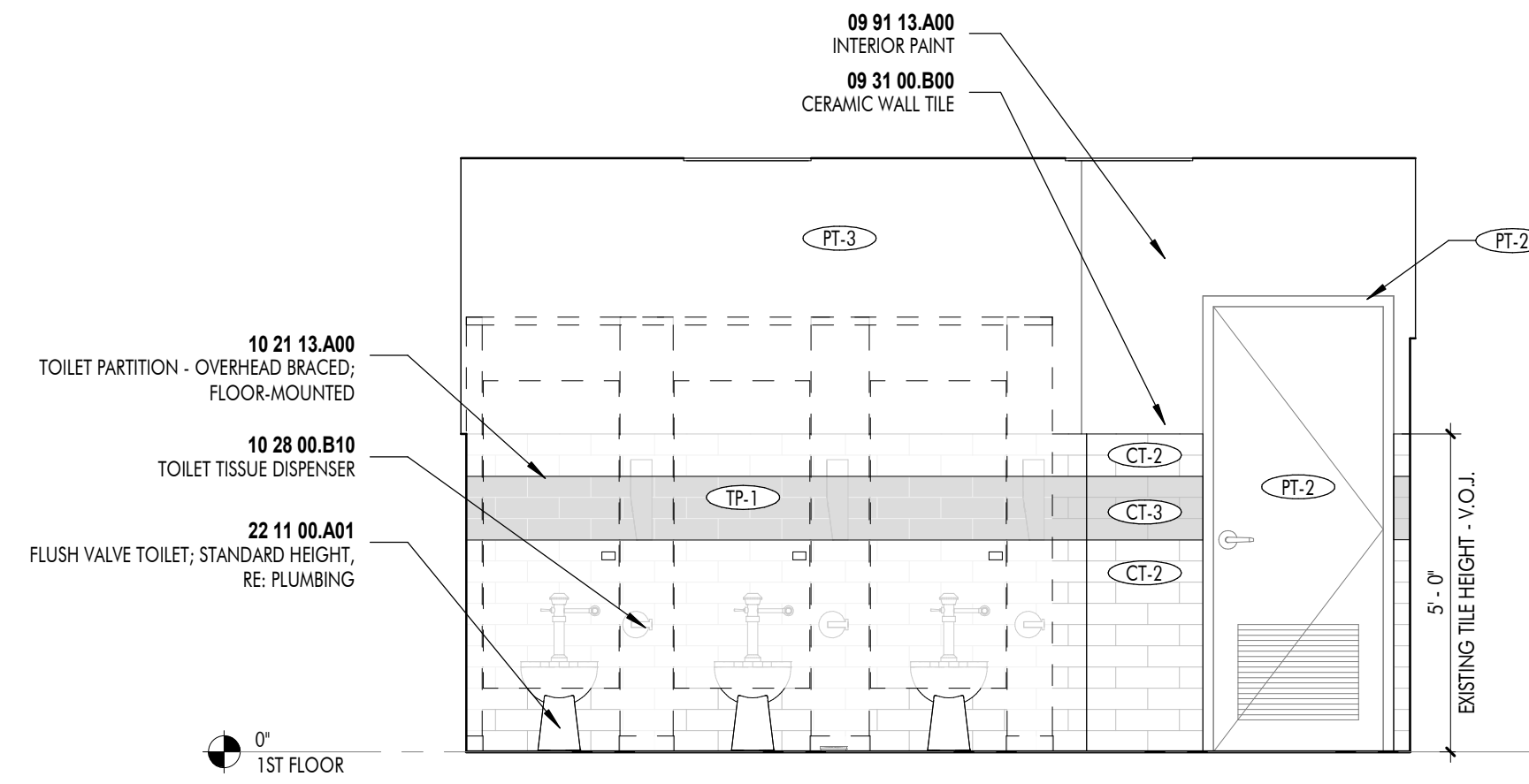
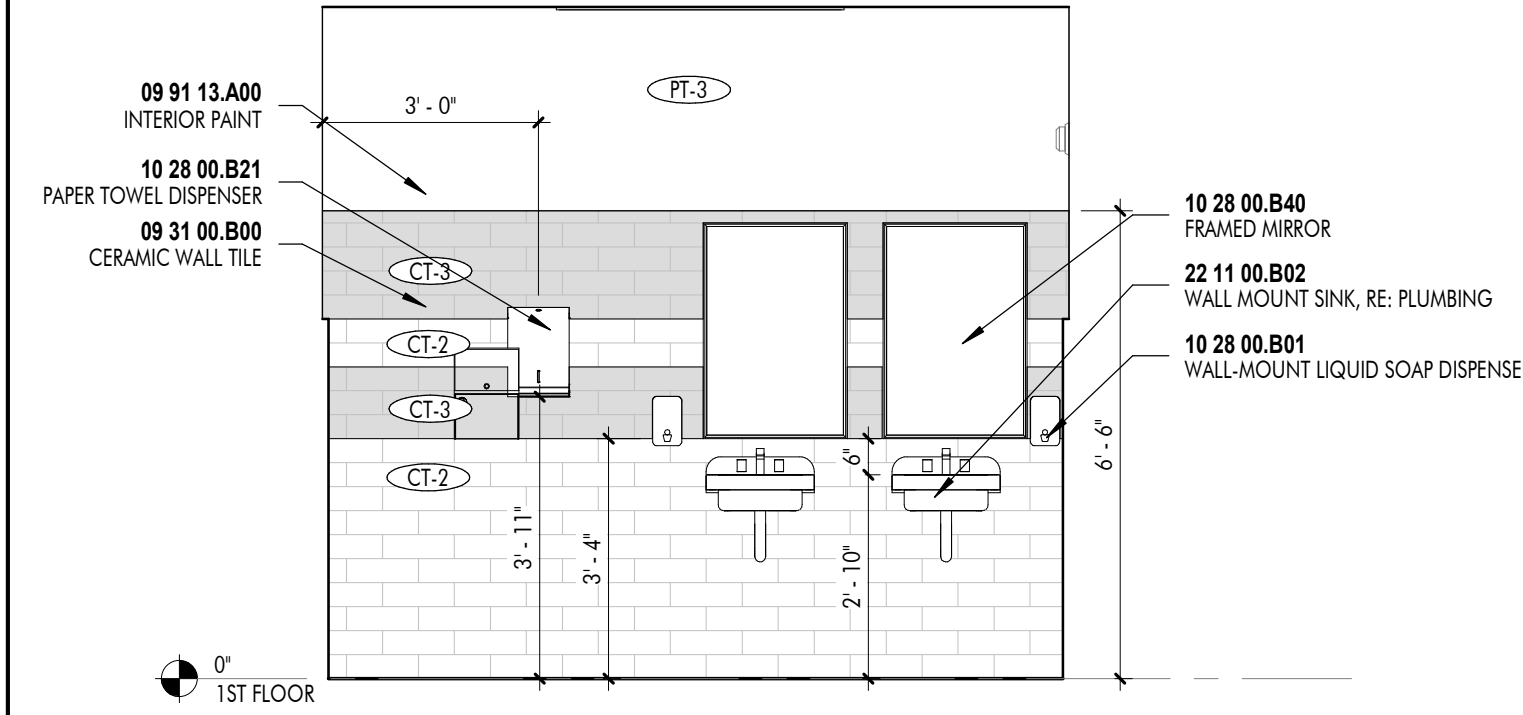
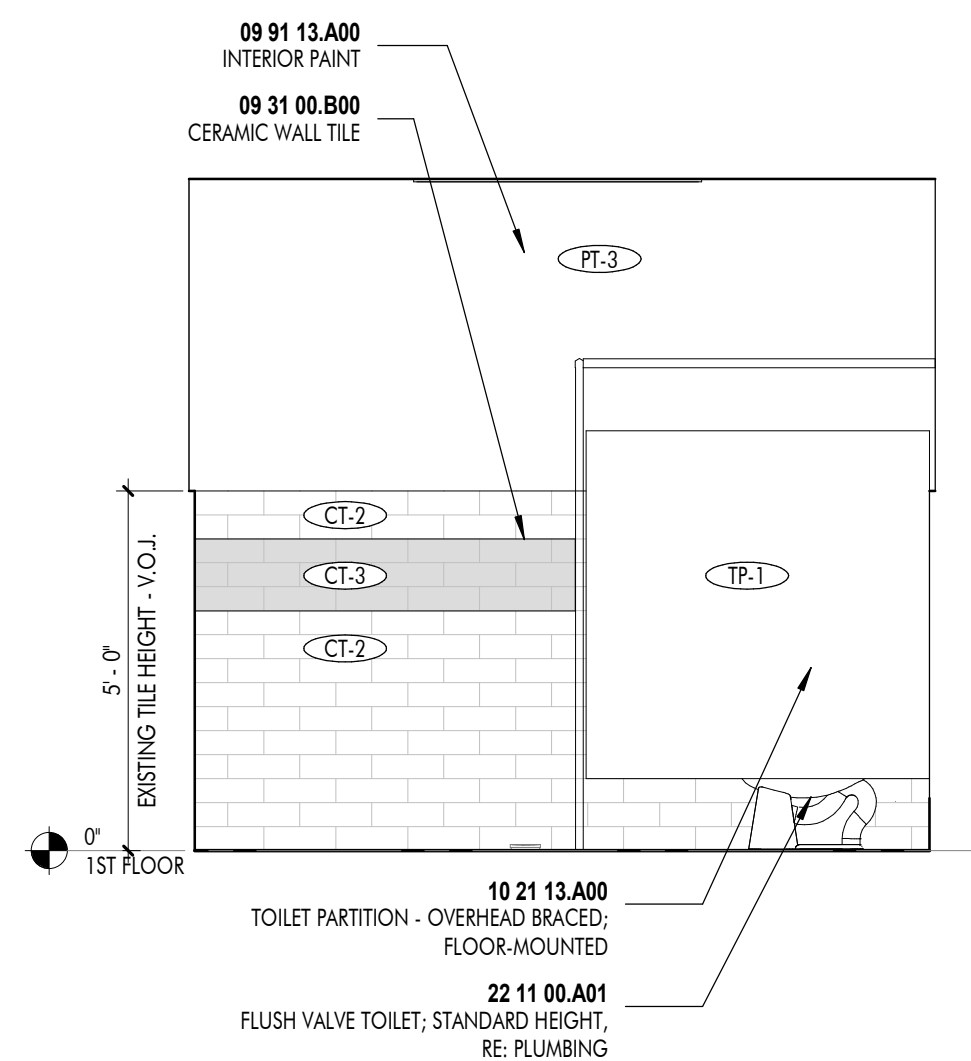
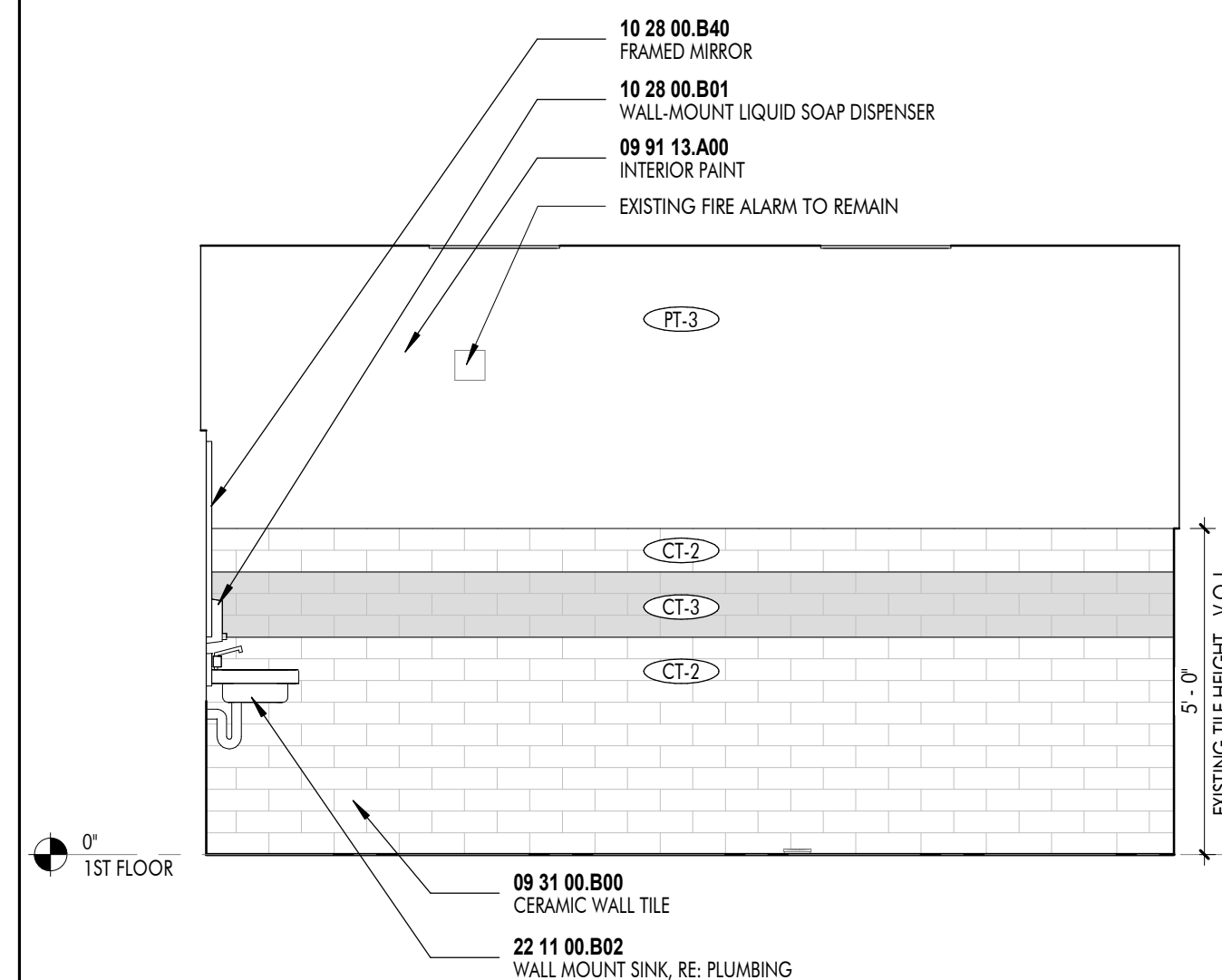

**5** 1ST FLOOR GIRLS - NORTH  
3/8" = 1'-0" DRAWN BY: KAS

**6** 1ST FLOOR GIRLS - EAST  
3/8" = 1'-0" DRAWN BY: KAS

**7** 1ST FLOOR GIRLS - WEST  
3/8" = 1'-0" DRAWN BY: KAS

**8** 1ST FLOOR GIRLS - SOUTH  
3/8" = 1'-0" DRAWN BY: KAS

ARCHITECT

**DOMAIN**  
ARCHITECTURE

816 kelwood  
avenue  
baton rouge, la 70806  
t: 225.216.3770 f: 225.216.3771  
www.domain-arch.com

REGISTRATION

STATE OF LOUISIANA  
REGISTERED ARCHITECT

These drawings are the property of DOMAIN ARCHITECTURE APAC and are not to be reproduced in whole or in part. They are only to be used for the project and site specifically identified herein. Scales stated herein are valid on the original drawing only. Contractor shall carefully review all dimensions and conditions shown and report to the architect any errors, inconsistencies, or omissions discovered. These plans were prepared in the office under our personal supervision, and to the best of our knowledge comply with state and local codes. We will generally administer construction.

CLIENT

Southern University Laboratory School  
**RESTROOM RENOVATIONS**  
129 SWAN AVE,  
BATON ROUGE, LA 70813

PROJECT INFORMATION		
revisions	Date	Description

project # **C22-0072**  
date **AUGUST 31, 2023**  
director review

GIRLS  
**A9.08**

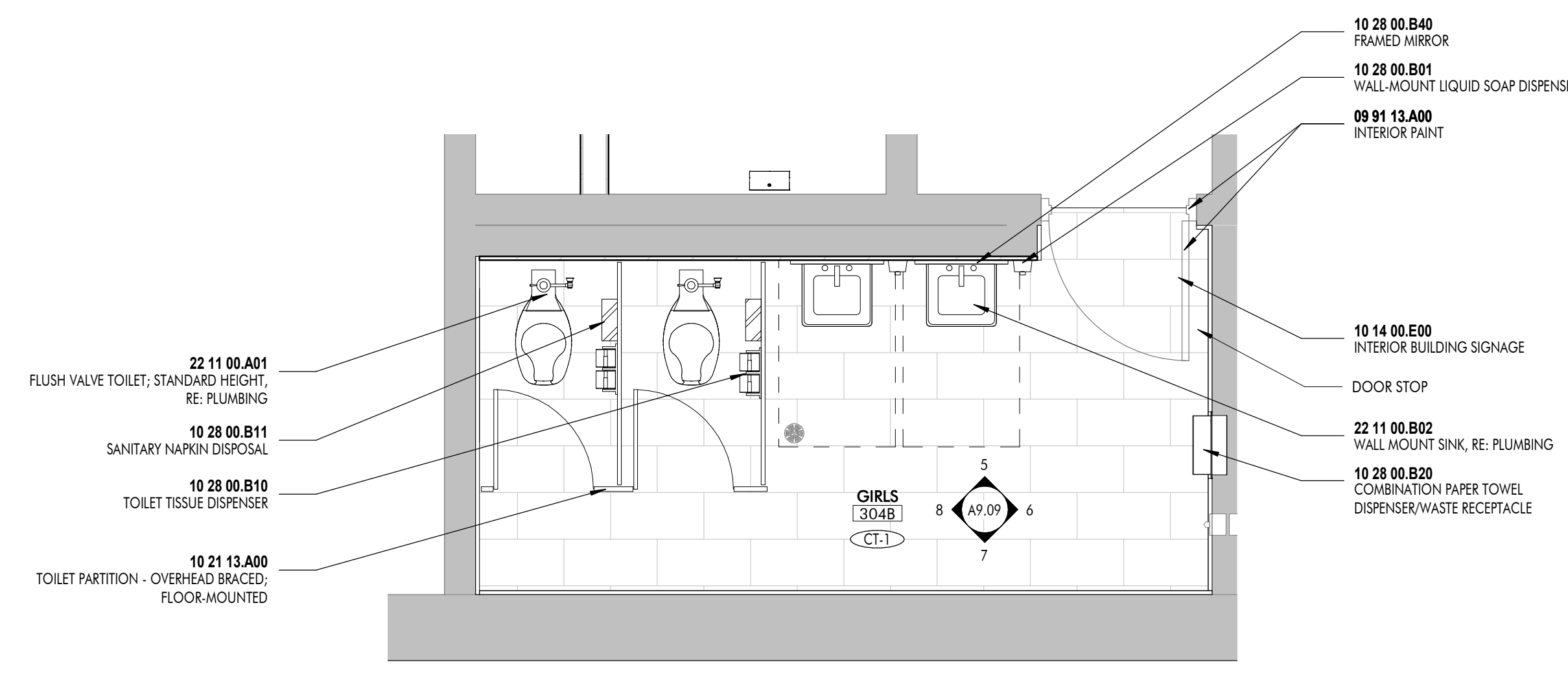
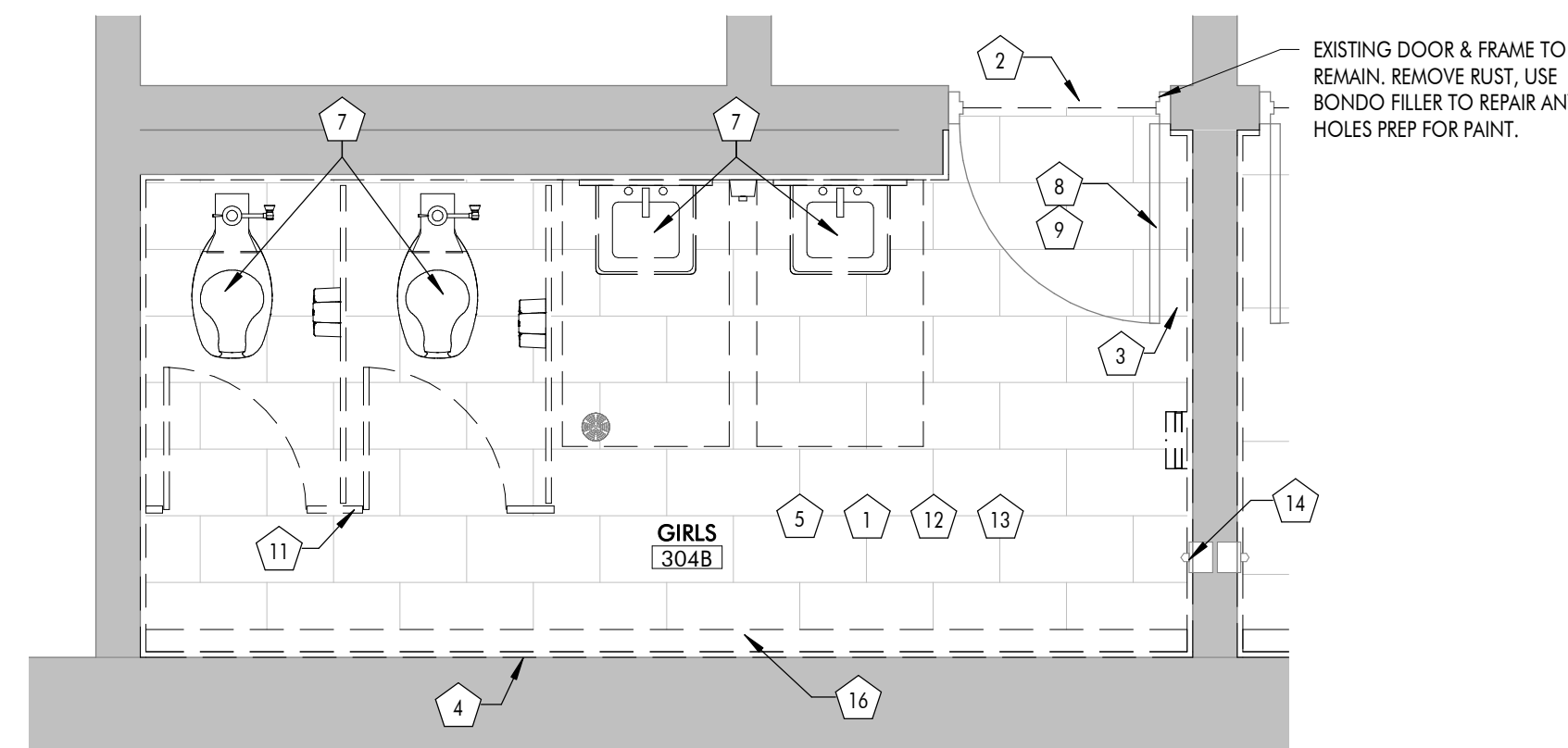

CONSTRUCTION NOTES	
MARK	DESCRIPTION
1	REMOVE EXISTING FLOOR TILE. PATCH AND PREP FLOOR TO RECEIVE NEW TILE AS SCHEDULED. PROVIDE LEVELING COMPOUND AS NECESSARY. MOISTURE TEST EXISTING FLOOR BEFORE NEW FLOOR IS INSTALLED. THOROUGHLY CLEAN EXISTING FLOOR DRAIN.
2	MARBLE THRESHOLD TO BE PROTECTED FOR DURATION OF CONSTRUCTION. THRESHOLD TO BE CLEANED AT END OF CONSTRUCTION.
3	REMOVE DOORSTOP. PATCH AND PREP FLOOR TO RECEIVE NEW DOORSTOP.
4	REMOVE PAINT AND RUST FROM EXISTING STOREFRONT. PREP SURFACE TO RECEIVE NEW PAINT.
5	CONTRACTOR TO ENSURE WALL IS A FINISH LEVEL OF 4. REMOVE ANY FLAKING PAINT. SAND WALL FOR SMOOTH SURFACE AND PREP FOR NEW PAINT.
6	CAREFULLY REMOVE ANY EXISTING INTERIOR SIGNAGE. PATCH AND PREP WALL FOR NEW PAINT.
7	REMOVE EXISTING PLUMBING FIXTURE. MAINTAIN EXISTING PLUMBING FOR REUSE.
8	THOROUGHLY CLEAN DOOR, FRAME AND HARDWARE. RE-CAULK DOOR FRAME. RE: ABATEMENT DRAWINGS.
9	REMOVE EXISTING PAINT ON DOOR AND DOOR FRAME. PREP DOOR AND DOOR FRAME TO RECEIVE NEW PAINT. RE: ABATEMENT DRAWINGS.
10	CAREFULLY REMOVE DOOR, FRAME AND HARDWARE. PREP OPENING FOR NEW DOOR. RE: ABATEMENT DRAWINGS.
11	REMOVE TOILET PARTITIONS. PATCH AND PREP WALL FOR NEW PAINT.
12	REMOVE ALL EXISTING RESTROOM ACCESSORIES, (INCLUDING BUT NOT LIMITED TO MIRROR, TOILET PAPER HOLDER, GRAB BARS, SOAP DISPENSER, PAPER TOWEL DISPENSER, TOILET CLEANER)
13	CAREFULLY REMOVE EXISTING TILE ON WALLS. PATCH AND PREP WALL TO RECEIVE NEW TILE.
14	MAINTAIN AND PROTECT FIRE ALARM AND ALL RELATED CONDUIT.
15	CONTRACTOR TO ENSURE CEILING IS A FINISH LEVEL OF 4. REMOVE ANY FLAKING PAINT. SAND CEILING FOR SMOOTH SURFACE AND PREP FOR NEW PAINT.
16	REMOVE EXISTING RADIATOR AND ALL ACCESSORIES ASSOCIATED WITH IT. PATCH AND PREP WALL.
17	PATCH HOLE IN THE WALL. PREP SURFACE TO RECEIVE NEW TILE.
18	REMOVE EXISTING LOCKERS.
19	REMOVE CONCRETE CURB. PROTECT SURROUNDING CONCRETE.
20	REMOVE EXISTING BENCH. PATCH AND PREP CONCRETE TO RECEIVE NEW SEAL.
21	REMOVE CEILING TILE AND GRID. PATCH AND PREP WALL TO RECEIVE NEW CEILING.
22	CAREFULLY REMOVE AND SALVAGE SUPPLY VENT FOR REUSE. REMOVE ANY PAINT FROM SURFACE AND CLEAN THOROUGHLY.
23	CAREFULLY REMOVE AND SALVAGE RETURN VENT FOR REUSE. REMOVE ANY PAINT FROM SURFACE AND CLEAN THOROUGHLY.
24	CAREFULLY REMOVE AND SALVAGE EXHAUST FAN FOR REUSE. REMOVE ANY PAINT FROM SURFACE AND CLEAN THOROUGHLY.
25	CAREFULLY REMOVE SURFACE MOUNTED LIGHT FIXTURE. ELECTRICAL TO REMAIN FOR REUSE.
26	REMOVE ALL LIGHT FIXTURES FROM ENTIRE ROOM. ELECTRICAL TO REMAIN FOR REUSE. CAP ANY ELECTRICAL NOT REUSED.
27	CAREFULLY REMOVE HANGING LIGHT FIXTURE. ELECTRICAL TO REMAIN FOR REUSE.
28	PREP PLASTER CEILING TO RECEIVE NEW PAINT.
29	PREP METAL CEILING TO RECEIVE NEW PAINT.
30	REMOVE DOOR, FRAME AND HARDWARE. PREPARE OPENING TO BE INFILLED.
31	REMOVE PORTION OF EXISTING WALL TO RECEIVE NEW DOOR.
A	MAIN STAGING AREA FOR CONTRACTOR
B	SUB-STAGING / PARKING AREA
C	STAGING AREAS SHALL BE REGRADED AND SEEDED WHEN THE CONSTRUCTION PROJECT HAS BEEN COMPLETED.
D	STAGING AREAS MUST BE FENCED AND LOCKABLE ALL TIMES.

**1** GIRLS GYM - DEMOLITION FLOOR PLAN  
3/8" = 1'-0" DRAWN BY: KAS

**2** GIRLS GYM - NEW CONSTRUCTION FLOOR PLAN  
3/8" = 1'-0" DRAWN BY: KAS

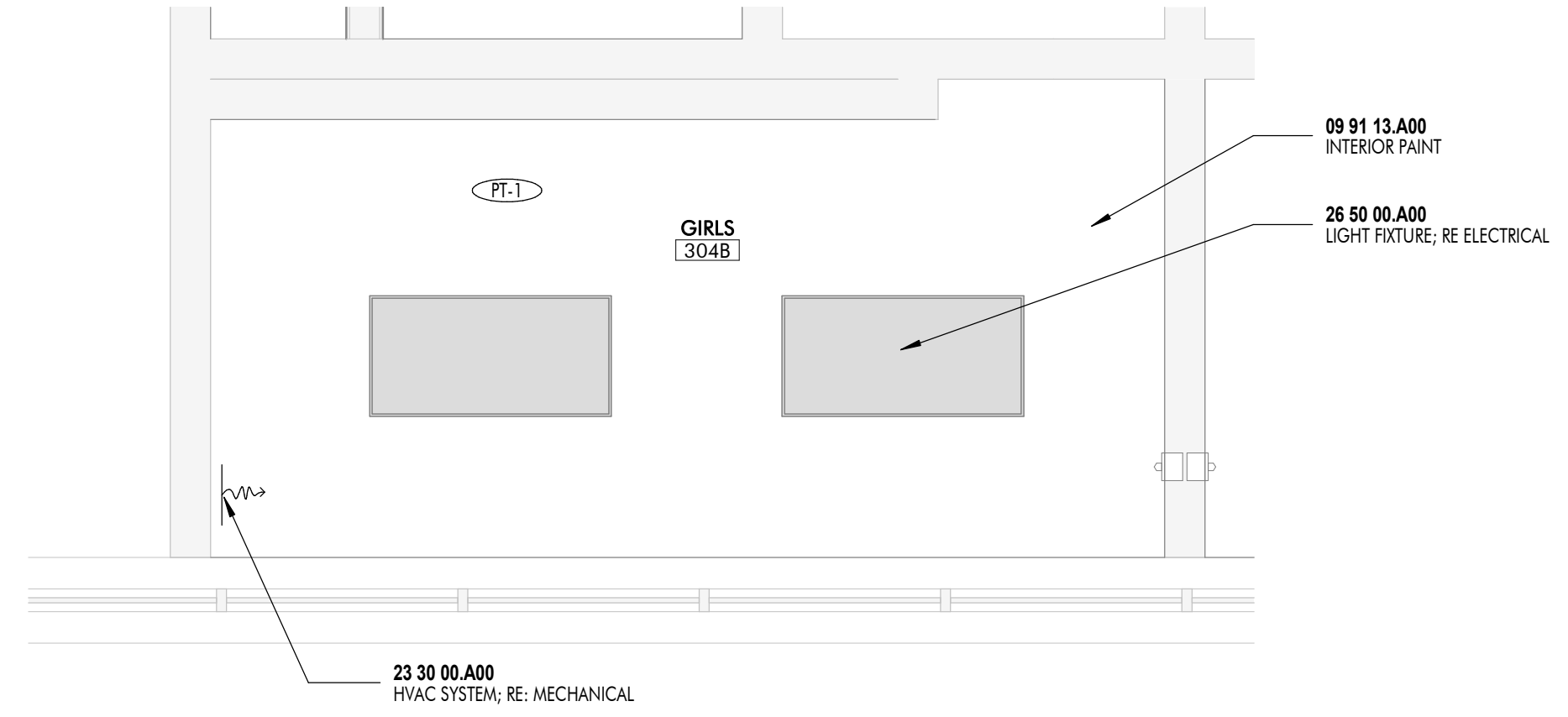
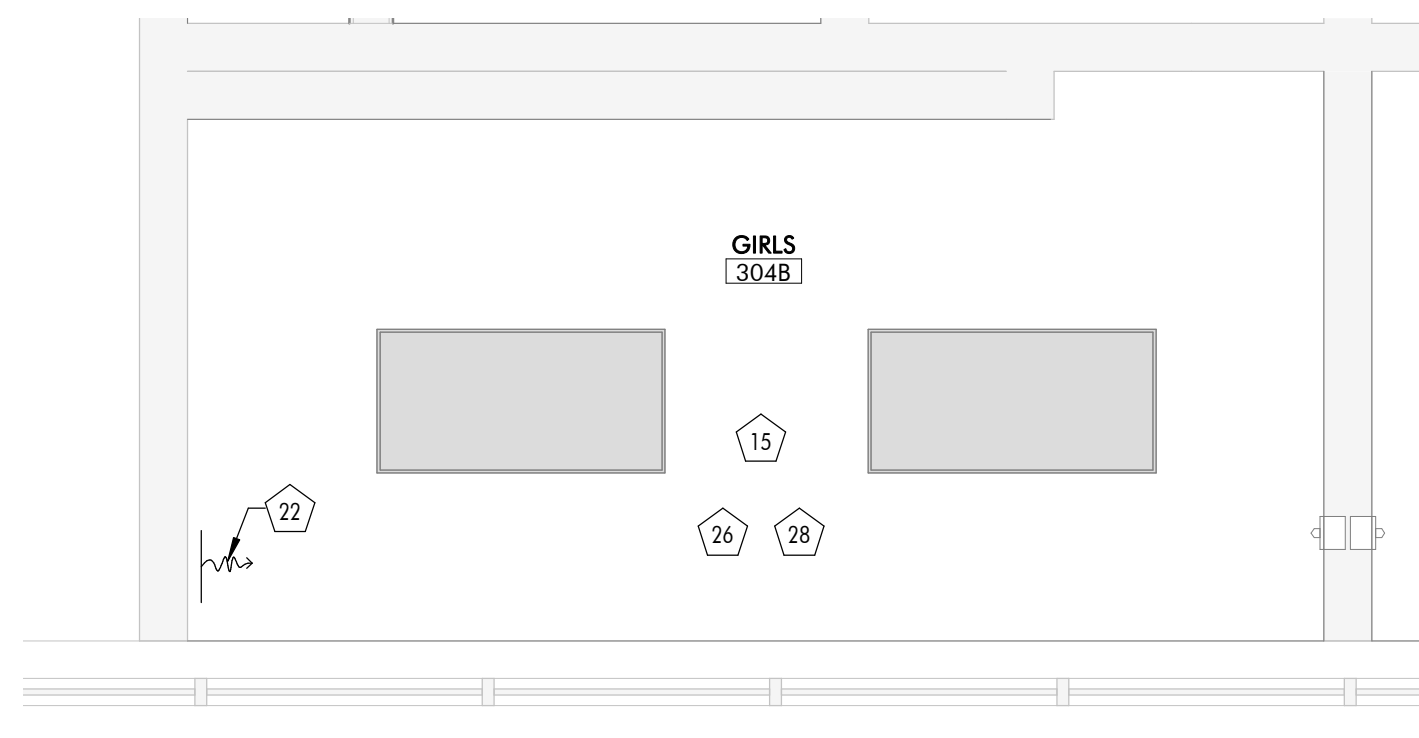

**3** GIRLS GYM - DEMOLITION RCP  
3/8" = 1'-0" DRAWN BY: KAS

**4** GIRLS GYM - NEW CONSTRUCTION RCP  
3/8" = 1'-0" DRAWN BY: KAS

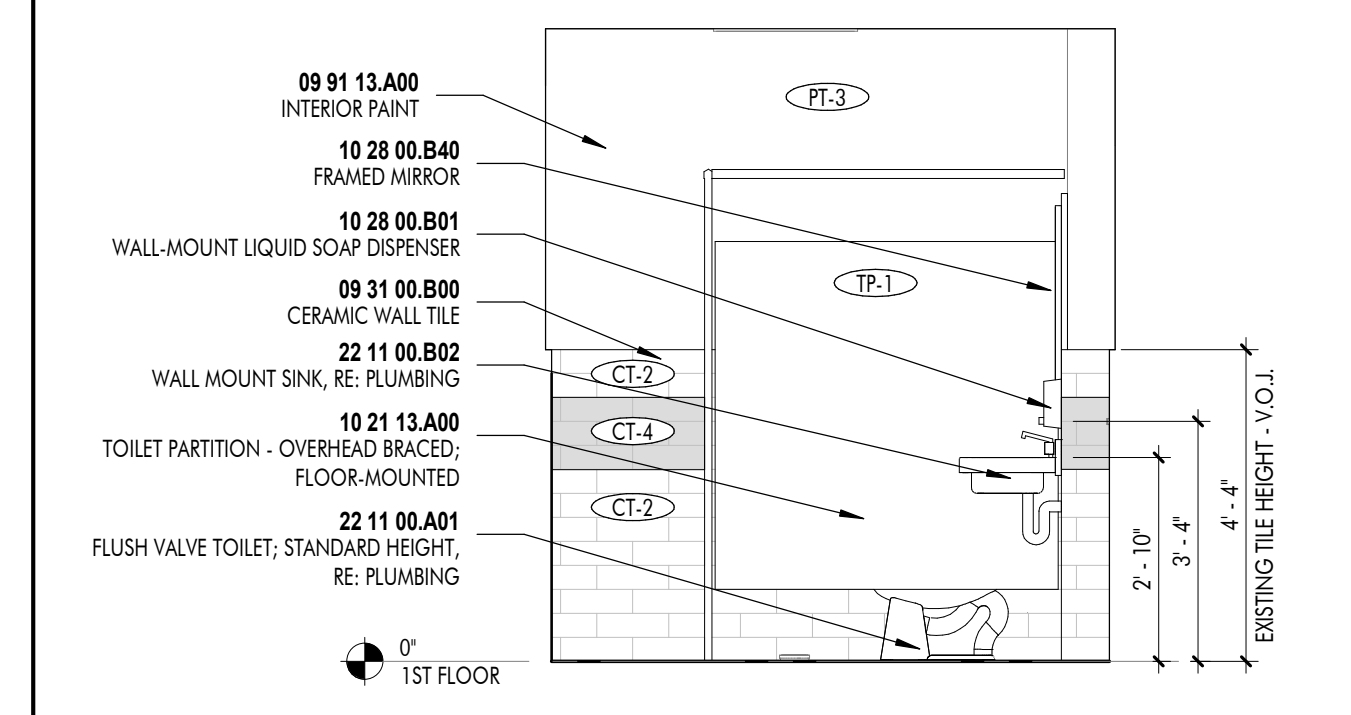
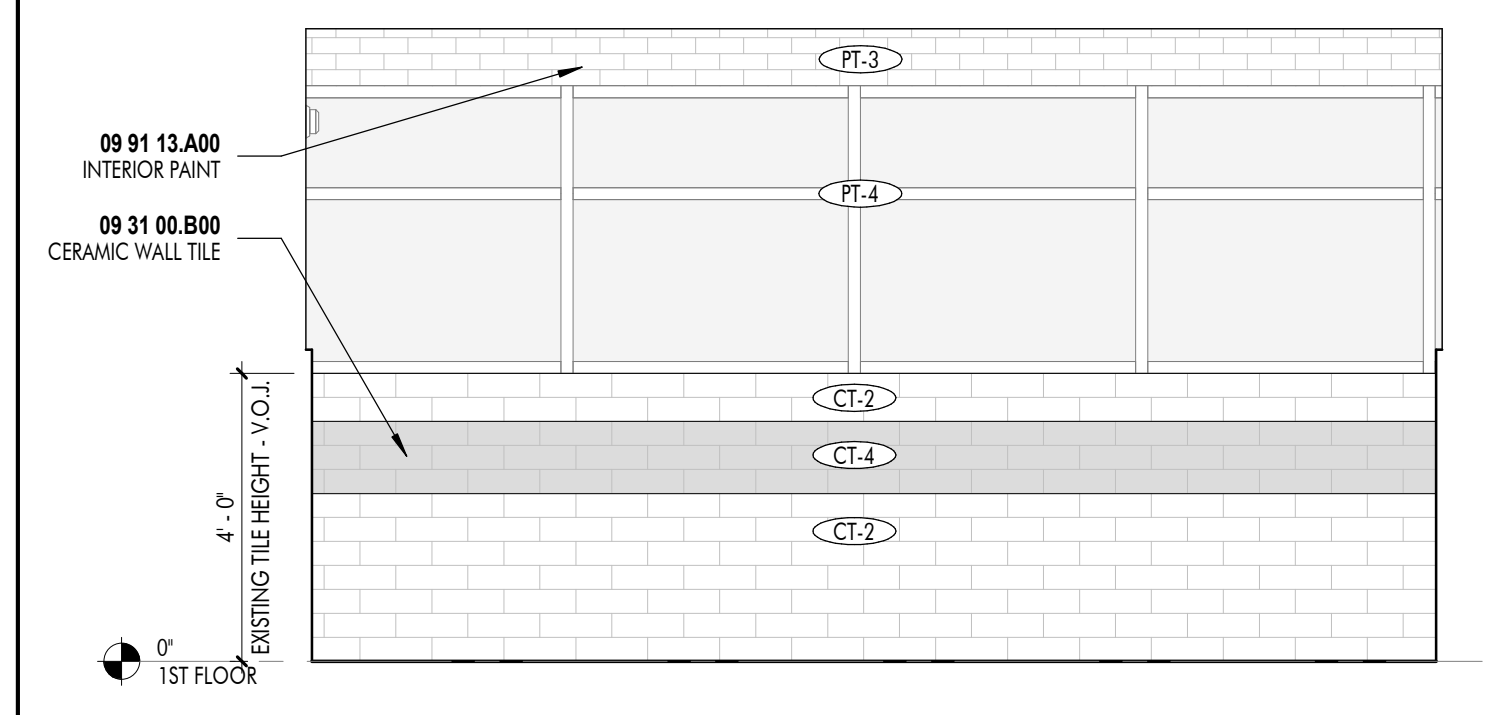
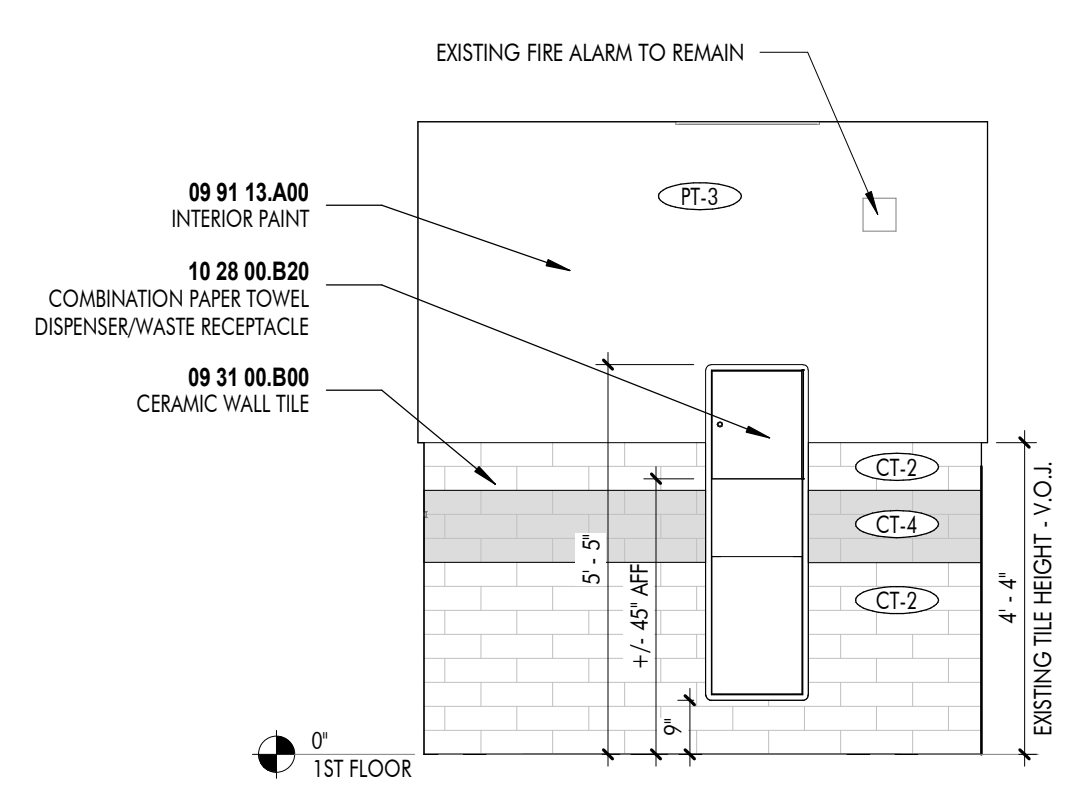
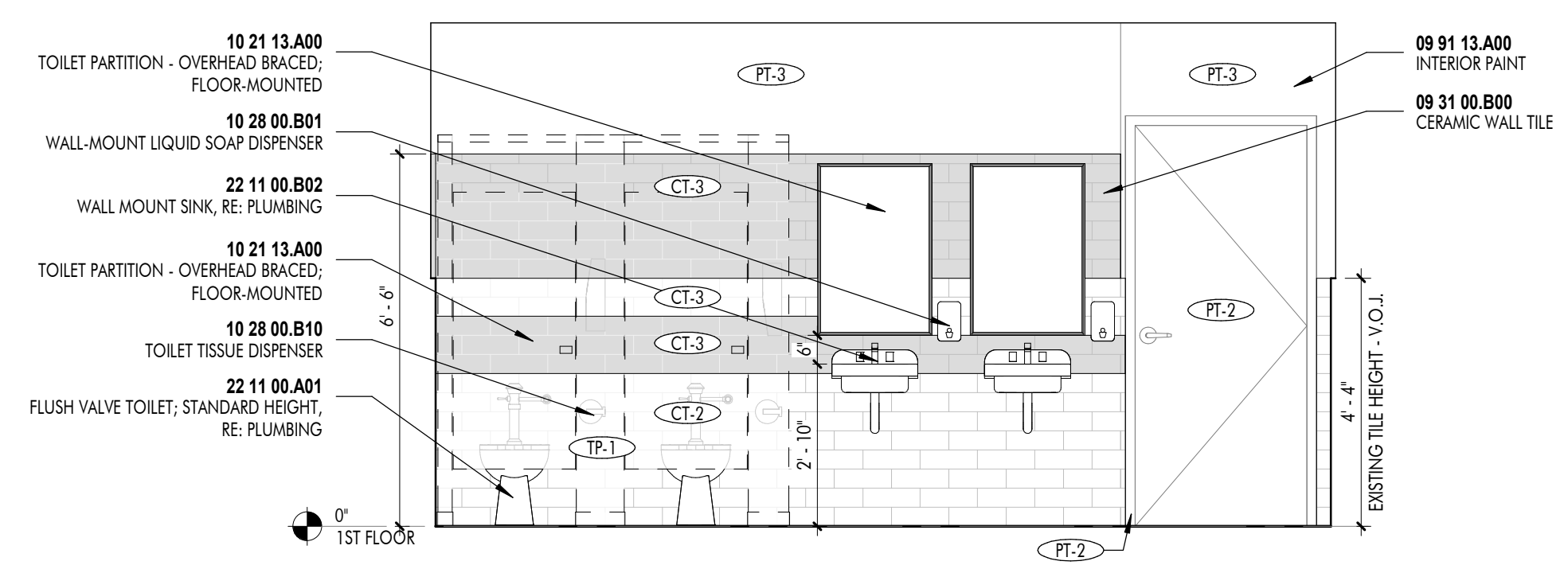

**5** GIRLS GYM - NORTH  
3/8" = 1'-0" DRAWN BY: KAS

**6** GIRLS GYM - EAST  
3/8" = 1'-0" DRAWN BY: KAS

**7** GIRLS GYM - SOUTH  
3/8" = 1'-0" DRAWN BY: KAS

**8** GIRLS GYM - WEST  
3/8" = 1'-0" DRAWN BY: KAS

ARCHITECT

**DOMAIN**  
 ARCHITECTURE  
 APAC

8316 kelwood avenue, baton rouge, la 70806  
 t: 225.216.3770 f: 225.216.3771  
 www.domain-arch.com

REGISTRATION

These drawings are the property of DOMAIN ARCHITECTURE APAC and are not to be reproduced in whole or in part. They are only to be used for the project and site specifically identified herein. Scales stated herein are valid on the original drawing only. Contractor shall carefully review all dimensions and conditions shown and report to the architect any errors, inconsistencies, or omissions discovered. These plans were prepared in the office under our personal supervision, and to the best of our knowledge comply with state and local codes. We will generally administer construction.

CLIENT

Southern University Laboratory School  
**RESTROOM RENOVATIONS**  
 129 SWAN AVE,  
 BATON ROUGE, LA 70813

PROJECT INFORMATION	
Date	Description

project # **C22-0072**  
 date **AUGUST 31, 2023**

director review

GYM GIRLS

**A9.09**

Southern University Laboratory School  
**RESTROOM RENOVATIONS**

129 SWAN AVE,  
BATON ROUGE, LA 70813

PROJECT INFORMATION	
revisions	Date
No.	Description

project # **C22-0072**  
date **AUGUST 31, 2023**  
director review

CONSTRUCTION NOTES	
MARK	DESCRIPTION
1	REMOVE EXISTING FLOOR TILE. PATCH AND PREP FLOOR TO RECEIVE NEW TILE AS SCHEDULED. PROVIDE LEVELING COMPOUND AS NECESSARY. MOISTURE TEST EXISTING FLOOR BEFORE NEW FLOOR IS INSTALLED. THOROUGHLY CLEAN EXISTING FLOOR DRAIN.
2	MARBLE THRESHOLD TO BE PROTECTED FOR DURATION OF CONSTRUCTION. THRESHOLD TO BE CLEANED AT END OF CONSTRUCTION.
3	REMOVE DOORSTOP. PATCH AND PREP FLOOR TO RECEIVE NEW DOORSTOP.
4	REMOVE PAINT AND RUST FROM EXISTING STOREFRONT. PREP SURFACE TO RECEIVE NEW PAINT.
5	CONTRACTOR TO ENSURE WALL IS A FINISH LEVEL OF 4. REMOVE ANY FLAKING PAINT. SAND WALL FOR SMOOTH SURFACE AND PREP FOR NEW PAINT.
6	CAREFULLY REMOVE ANY EXISTING INTERIOR SIGNAGE. PATCH AND PREP WALL FOR NEW PAINT.
7	REMOVE EXISTING PLUMBING FIXTURE. MAINTAIN EXISTING PLUMBING FOR REUSE.
8	THOROUGHLY CLEAN DOOR, FRAME AND HARDWARE. RE-CAULK DOOR FRAME. RE: ABATEMENT DRAWINGS.
9	REMOVE EXISTING PAINT ON DOOR AND DOOR FRAME. PREP DOOR AND DOOR FRAME TO RECEIVE NEW PAINT. RE: ABATEMENT DRAWINGS.
10	CAREFULLY REMOVE DOOR, FRAME AND HARDWARE. PREP OPENING FOR NEW DOOR. RE: ABATEMENT DRAWINGS.
11	REMOVE TOILET PARTITIONS. PATCH AND PREP WALL FOR NEW PAINT.
12	REMOVE ALL EXISTING RESTROOM ACCESSORIES, (INCLUDING BUT NOT LIMITED TO MIRROR, TOILET PAPER HOLDER, GRAB BARS, SOAP DISPENSER, PAPER TOWEL DISPENSER, TOILET CLEANER)
13	CAREFULLY REMOVE EXISTING TILE ON WALLS. PATCH AND PREP WALL TO RECEIVE NEW TILE.
14	MAINTAIN AND PROTECT FIRE ALARM AND ALL RELATED CONDUIT.
15	CONTRACTOR TO ENSURE CEILING IS A FINISH LEVEL OF 4. REMOVE ANY FLAKING PAINT. SAND CEILING FOR SMOOTH SURFACE AND PREP FOR NEW PAINT.
16	REMOVE EXISTING RADIATOR AND ALL ACCESSORIES ASSOCIATED WITH IT. PATCH AND PREP WALL.
17	PATCH HOLE IN THE WALL. PREP SURFACE TO RECEIVE NEW TILE.
18	REMOVE EXISTING LOCKERS.
19	REMOVE CONCRETE CURB. PROTECT SURROUNDING CONCRETE.
20	REMOVE EXISTING BENCH. PATCH AND PREP CONCRETE TO RECEIVE NEW SEAL.
21	REMOVE CEILING TILE AND GRID. PATCH AND PREP WALL TO RECEIVE NEW CEILING.
22	CAREFULLY REMOVE AND SALVAGE SUPPLY VENT FOR REUSE. REMOVE ANY PAINT FROM SURFACE AND CLEAN THOROUGHLY.
23	CAREFULLY REMOVE AND SALVAGE RETURN VENT FOR REUSE. REMOVE ANY PAINT FROM SURFACE AND CLEAN THOROUGHLY.
24	CAREFULLY REMOVE AND SALVAGE EXHAUST FAN FOR REUSE. REMOVE ANY PAINT FROM SURFACE AND CLEAN THOROUGHLY.
25	CAREFULLY REMOVE SURFACE MOUNTED LIGHT FIXTURE. ELECTRICAL TO REMAIN FOR REUSE.
26	REMOVE ALL LIGHT FIXTURES FROM ENTIRE ROOM. ELECTRICAL TO REMAIN FOR REUSE. CAP ANY ELECTRICAL NOT REUSED.
27	CAREFULLY REMOVE HANGING LIGHT FIXTURE. ELECTRICAL TO REMAIN FOR REUSE.
28	PREP PLASTER CEILING TO RECEIVE NEW PAINT.
29	PREP METAL CEILING TO RECEIVE NEW PAINT.
30	REMOVE DOOR, FRAME AND HARDWARE. PREPARE OPENING TO BE INFILLED.
31	REMOVE PORTION OF EXISTING WALL TO RECEIVE NEW DOOR.
A	MAIN STAGING AREA FOR CONTRACTOR
B	SUB-STAGING / PARKING AREA
C	STAGING AREAS SHALL BE REGRADED AND SEEDED WHEN THE CONSTRUCTION PROJECT HAS BEEN COMPLETED.
D	STAGING AREAS MUST BE FENCED AND LOCKABLE ALL TIMES.

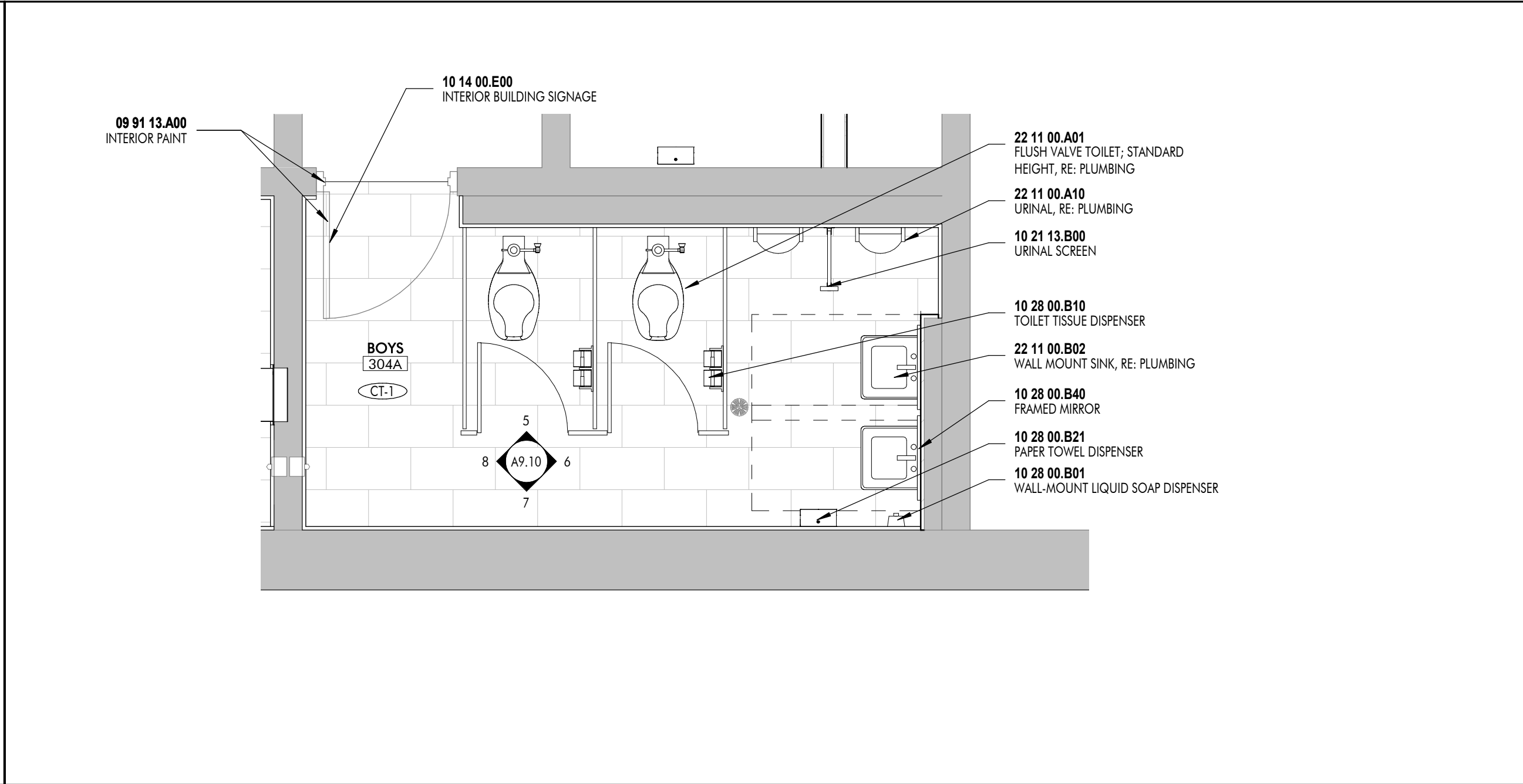

**2 BOYS GYM - NEW CONSTRUCTION FLOOR PLAN**  
3/8" = 1'-0" DRAWN BY: KAS

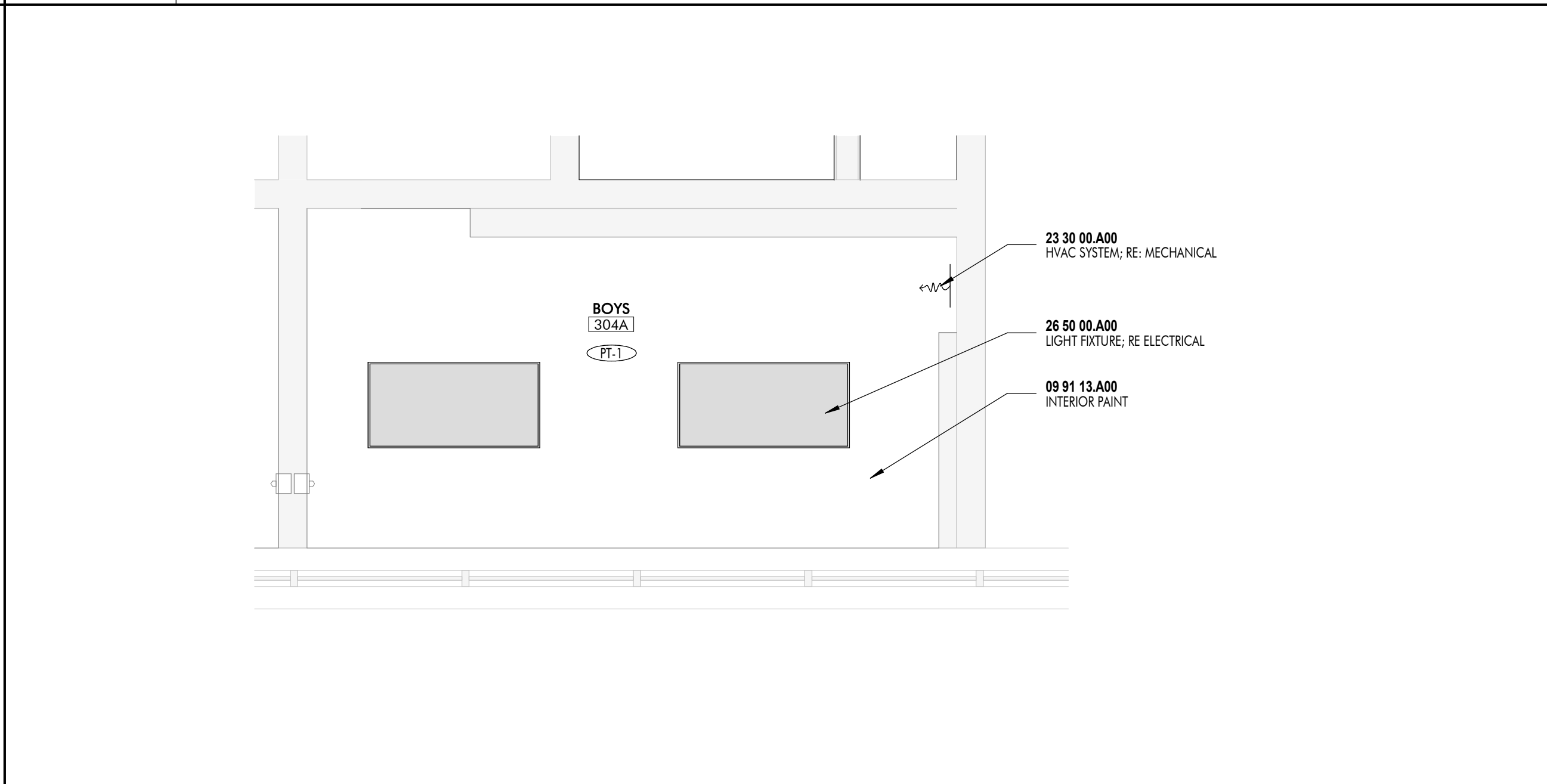

**4 BOYS GYM - NEW CONSTRUCTION RCP**  
3/8" = 1'-0" DRAWN BY: KAS

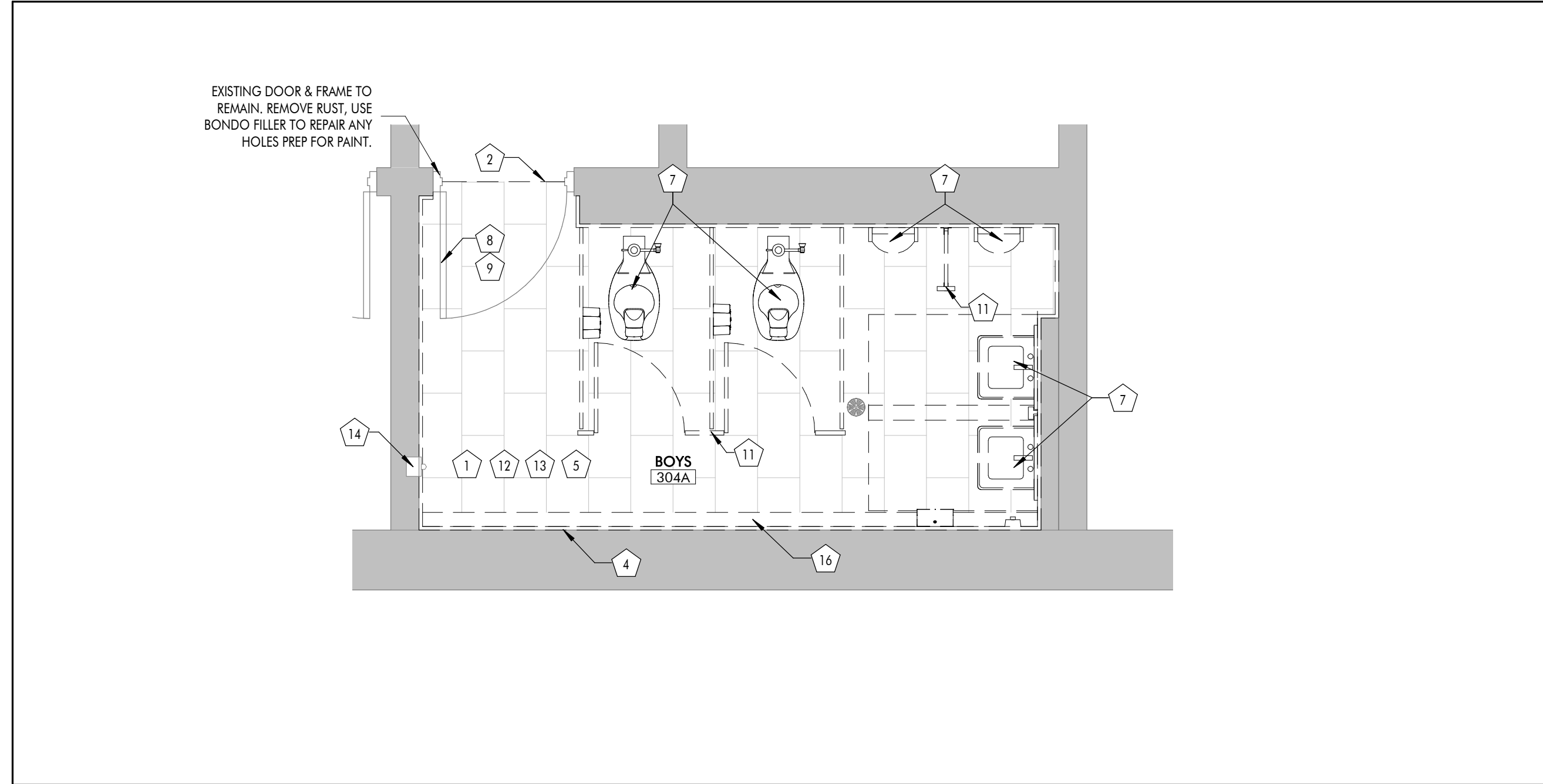

**1 BOYS GYM - DEMOLITION FLOOR PLAN**  
3/8" = 1'-0" DRAWN BY: KAS

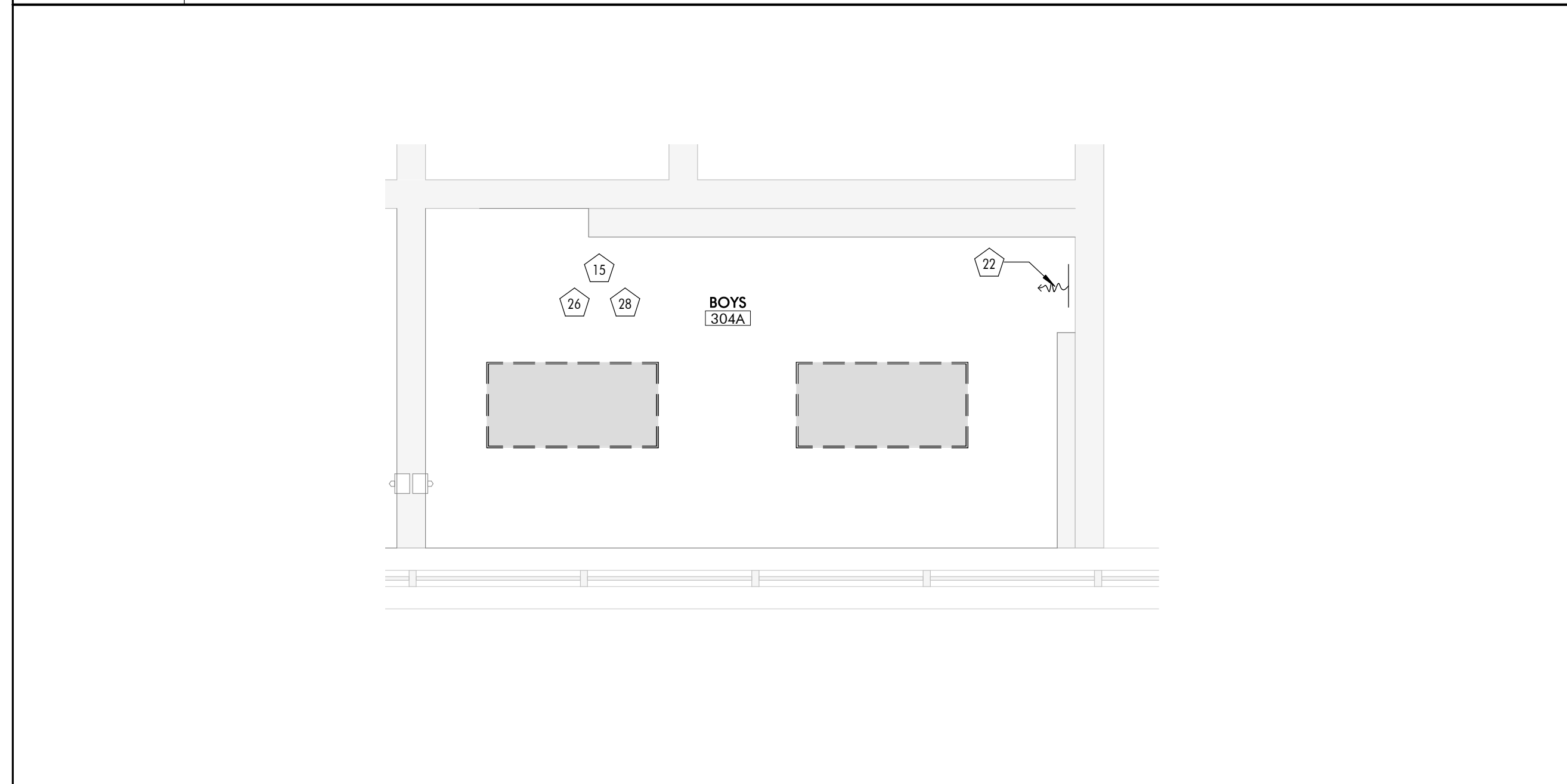

**3 BOYS GYM - DEMOLITION RCP**  
3/8" = 1'-0" DRAWN BY: KAS

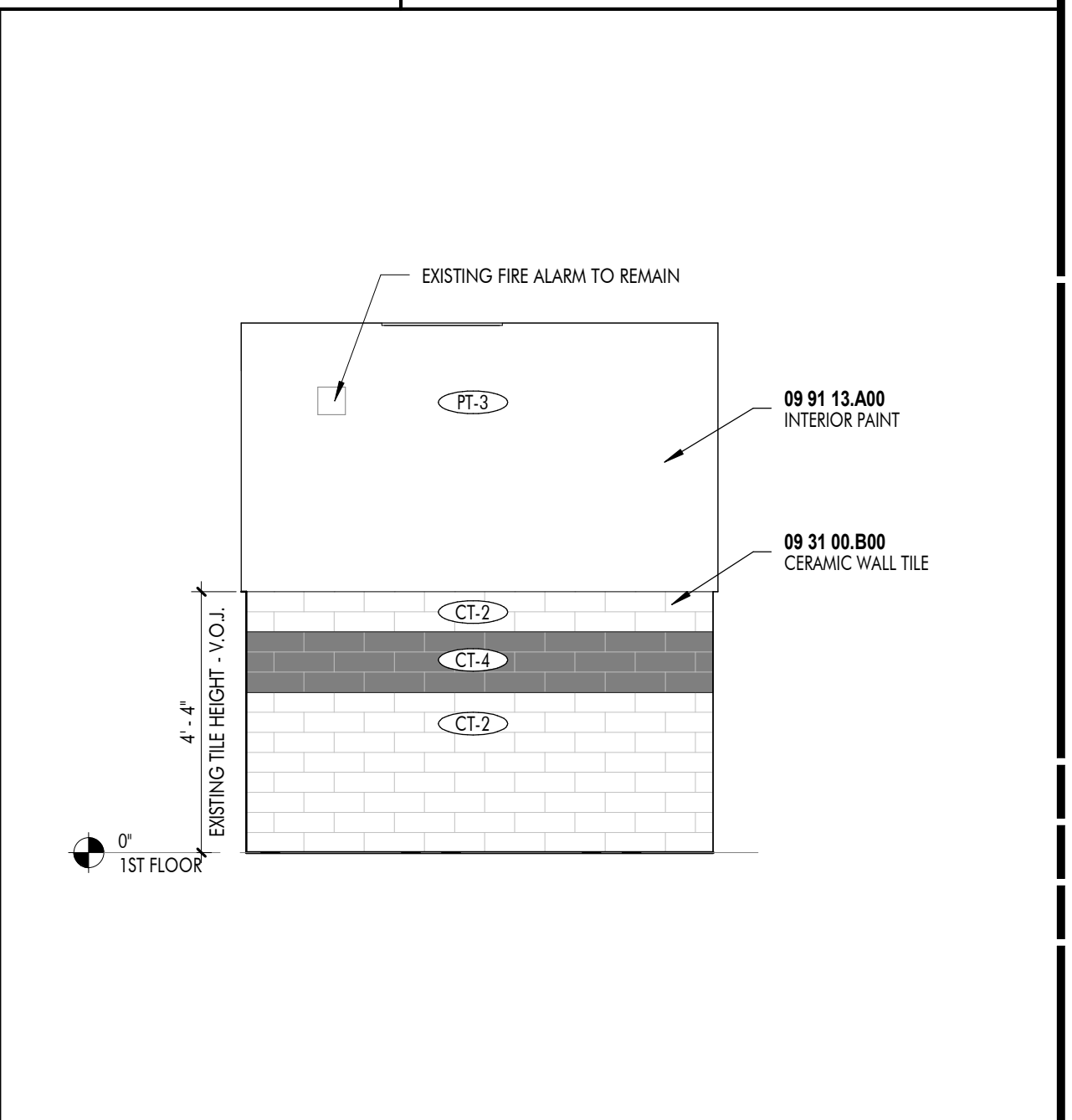

**8 BOYS GYM - WEST**  
3/8" = 1'-0" DRAWN BY: KAS

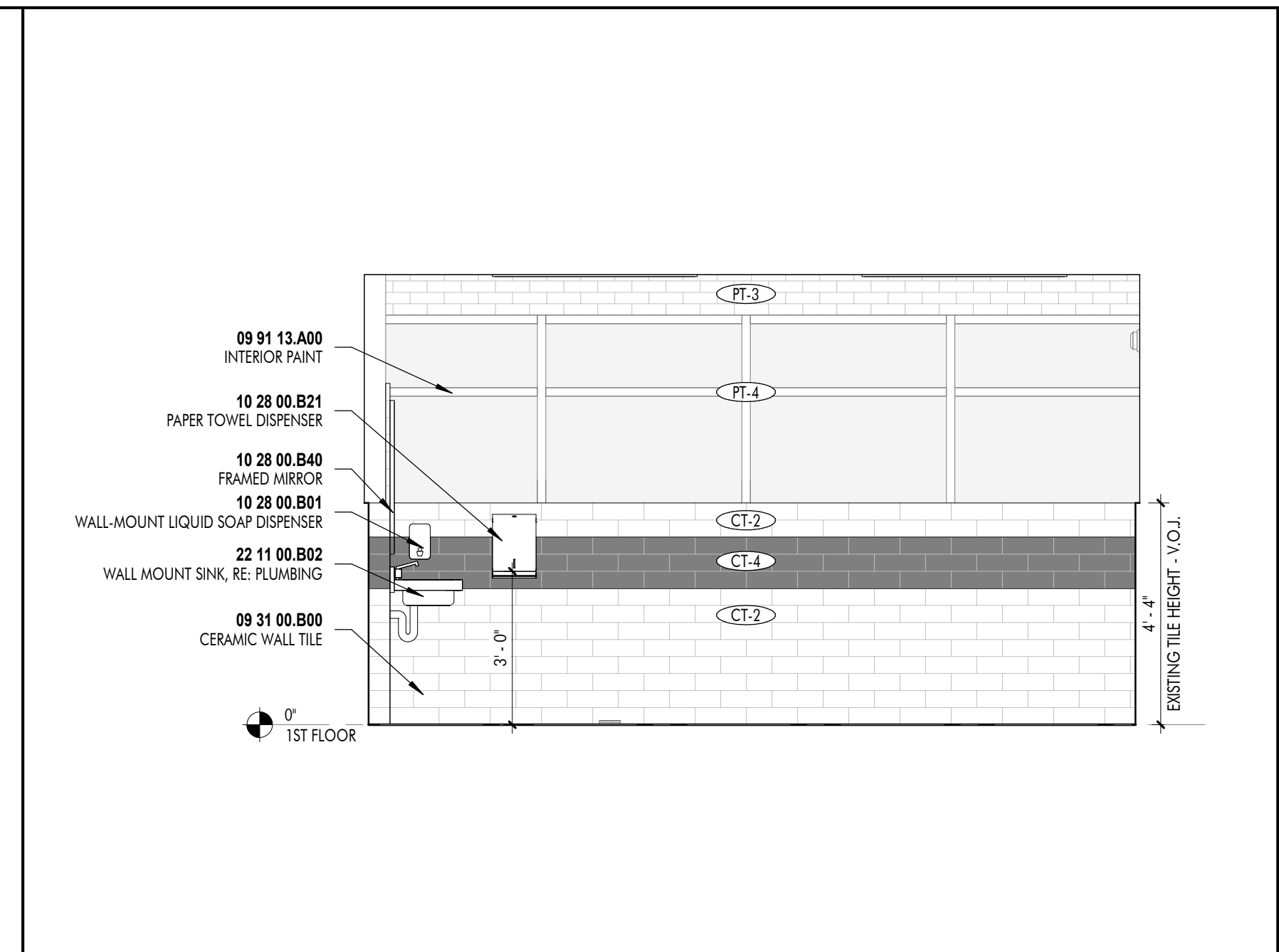

**7 BOYS GYM - SOUTH**  
3/8" = 1'-0" DRAWN BY: KAS

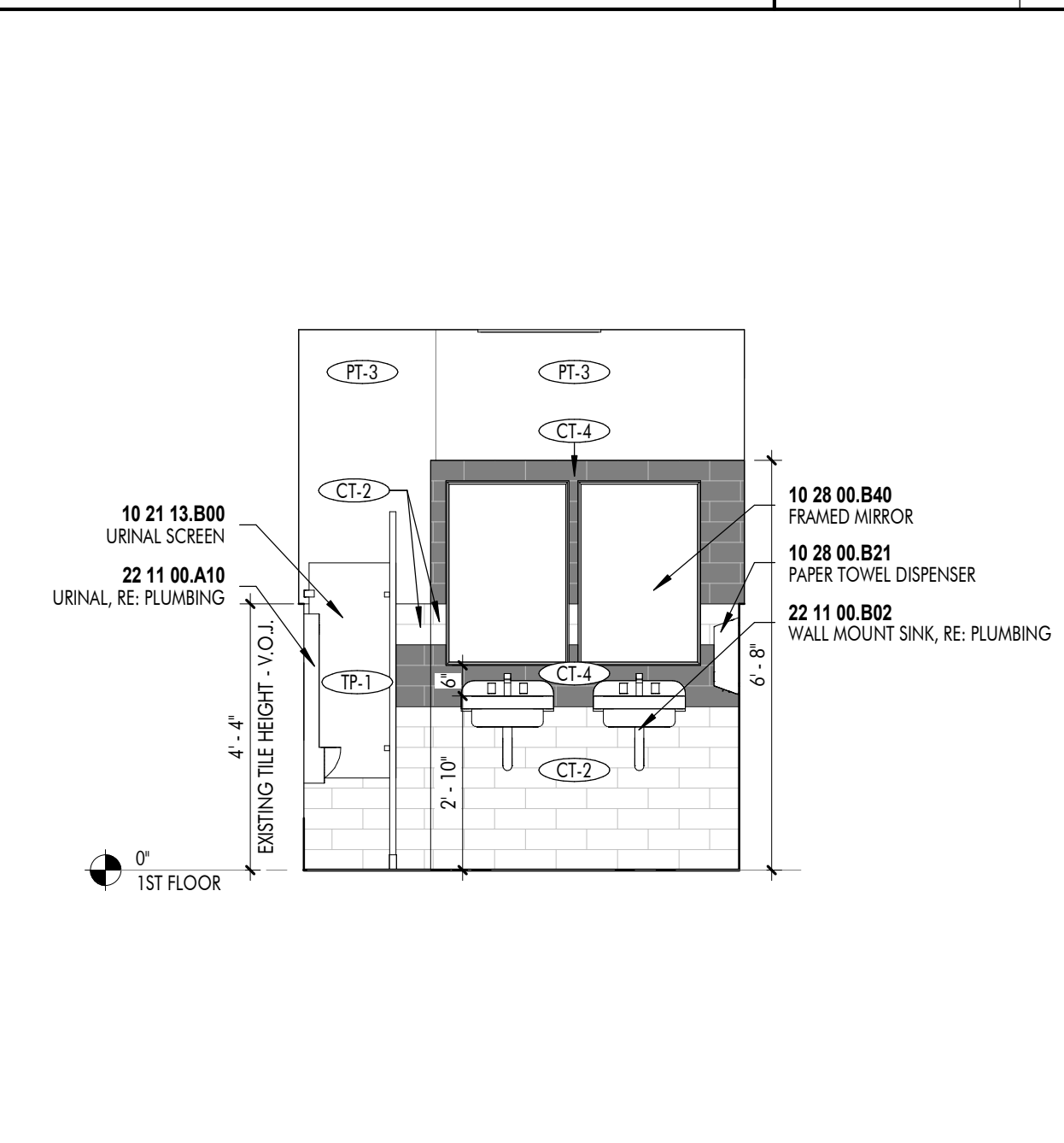

**6 BOYS GYM - EAST**  
3/8" = 1'-0" DRAWN BY: KAS

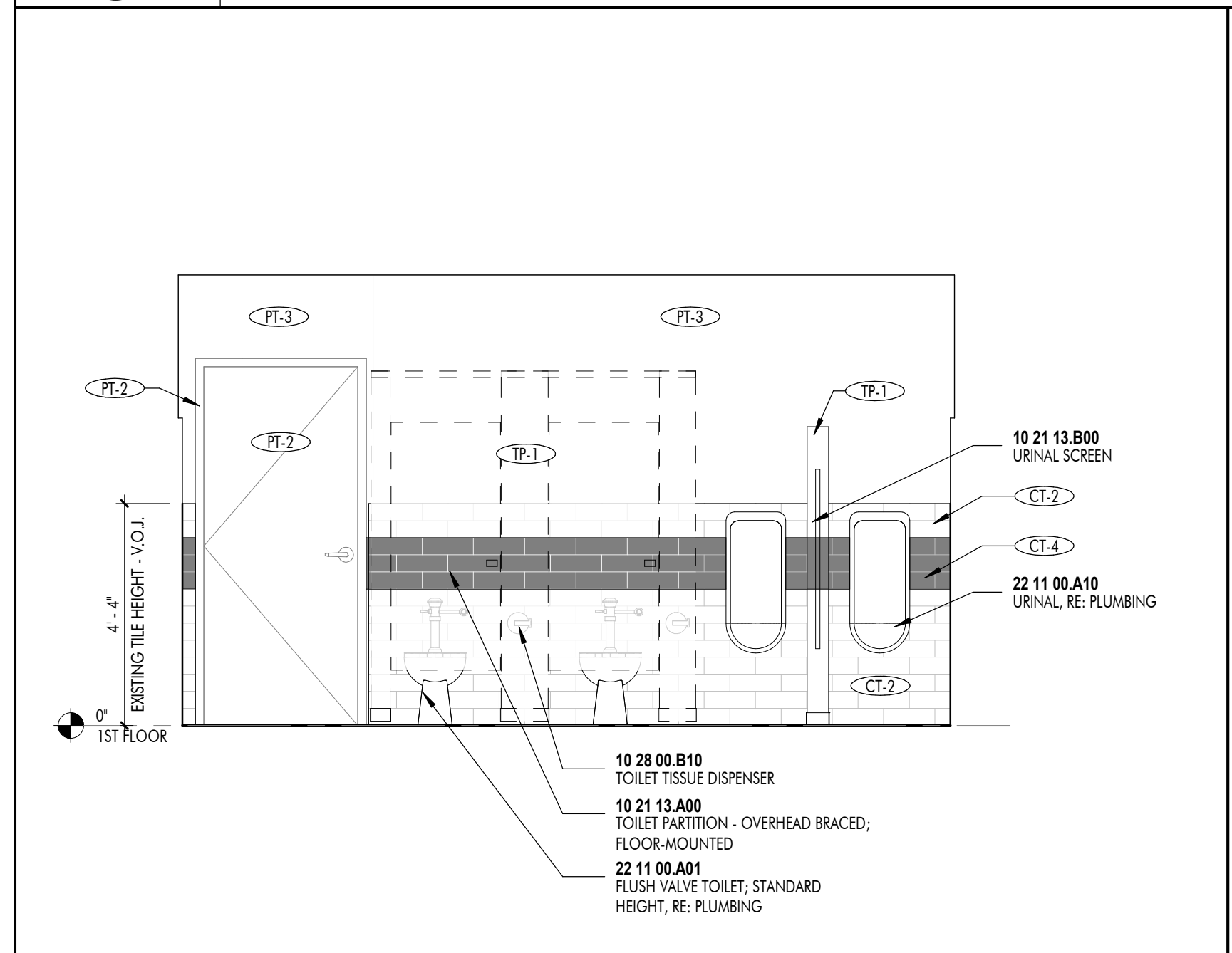

**5 BOYS GYM - NORTH**  
3/8" = 1'-0" DRAWN BY: KAS



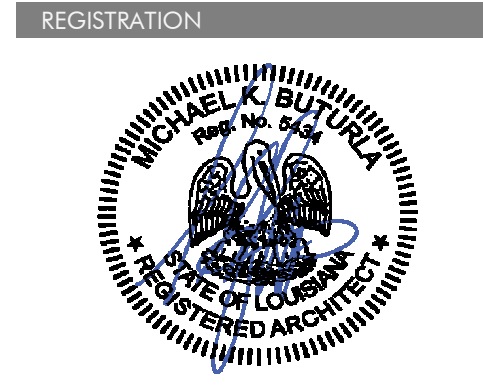

These drawings are the property of DOMAIN ARCHITECTURE APAC and are not to be reproduced in whole or in part. They are only to be used for the project and site specifically identified herein. Scales stated hereon are valid on the original drawing only. Contractor shall carefully review all dimensions and conditions shown and report to the architect any errors, inconsistencies, or omissions discovered. These plans were prepared in the office under our personal supervision, and to the best of our knowledge comply with state and local codes. We will generally administer construction.

CLIENT

Southern University Laboratory School  
**RESTROOM RENOVATIONS**

129 SWAN AVE,  
BATON ROUGE, LA 70813

PROJECT INFORMATION

revisions	No.	Description	Date

project # C22-0072

date AUGUST 31, 2023

director review

LOCKER ROOM  
ELEVATIONS

**A9.12**

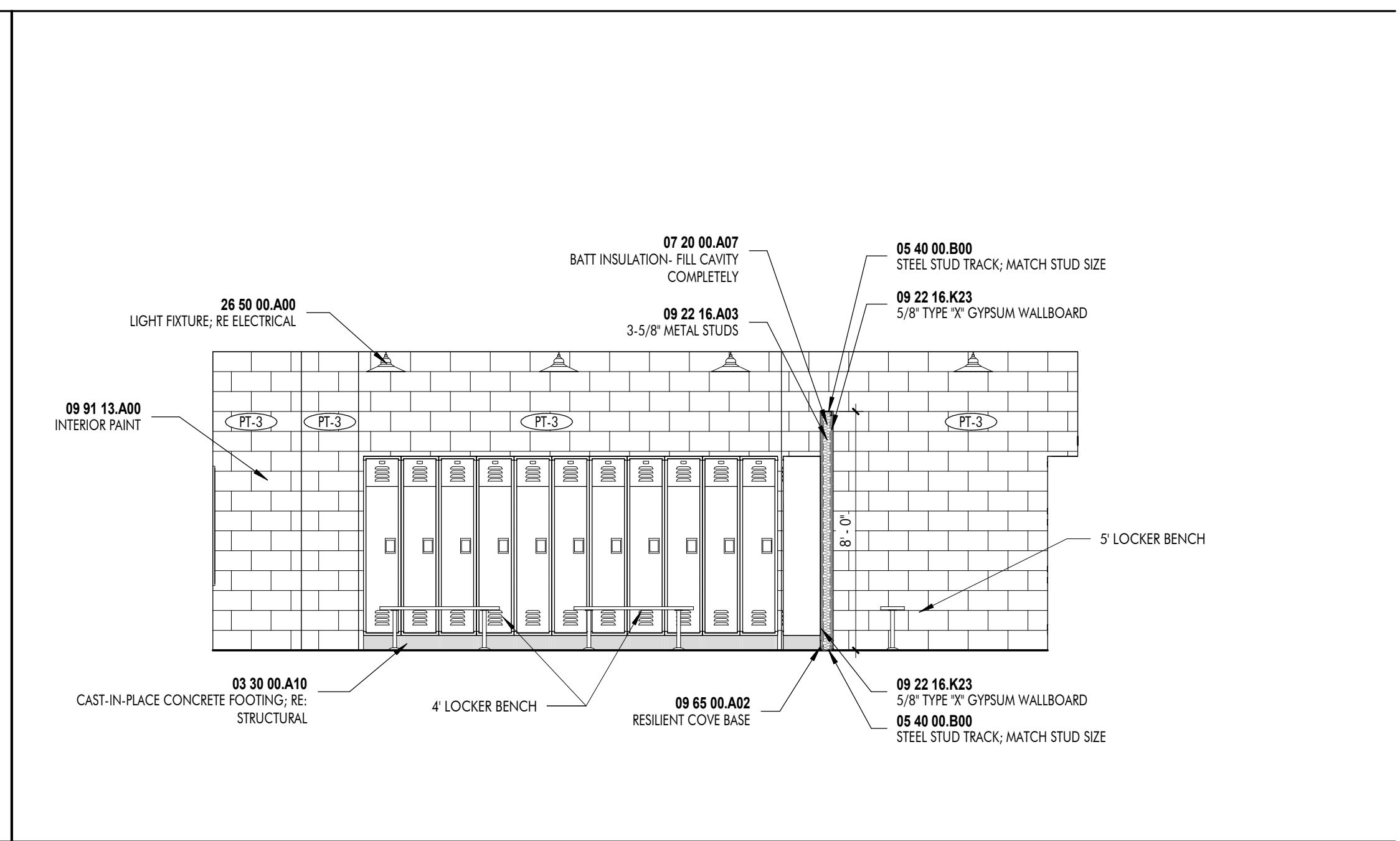
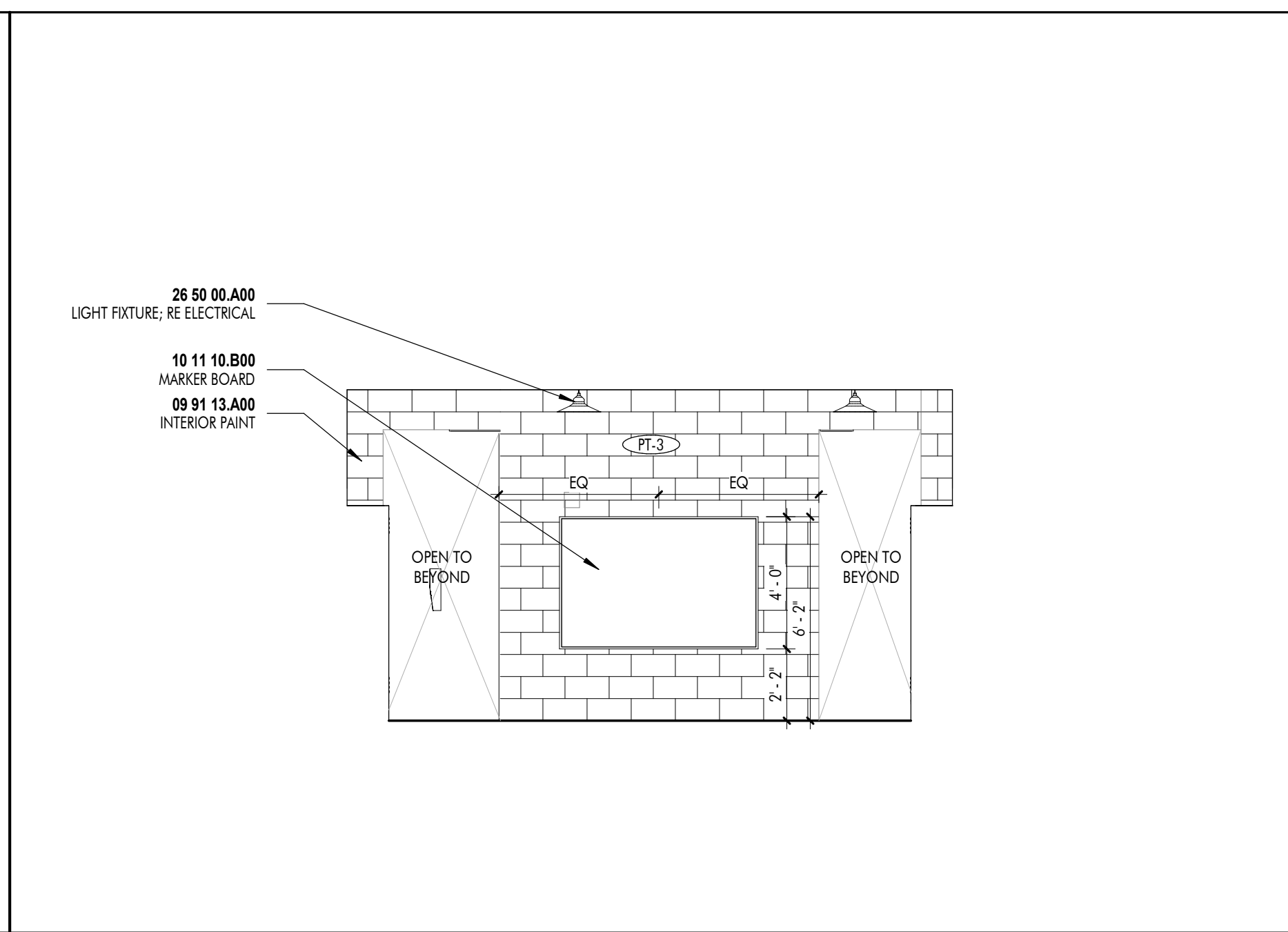
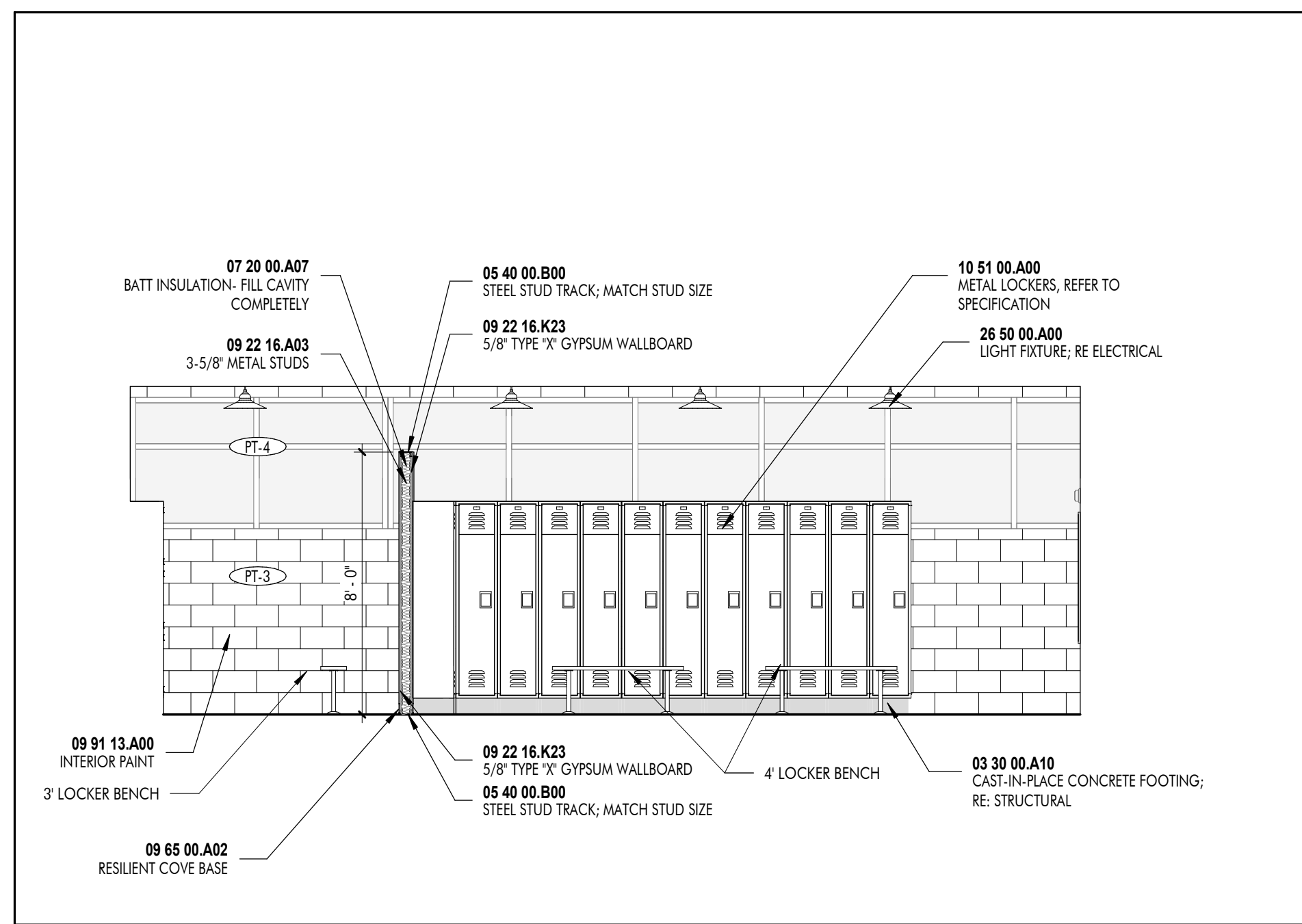

**1** LOCKER ROOM NORTH  
1/4" = 1'-0" DRAWN BY: KAS

**2** LOCKER ROOM EAST  
1/4" = 1'-0" DRAWN BY: KAS

**3** LOCKER ROOM SOUTH  
1/4" = 1'-0" DRAWN BY: KAS

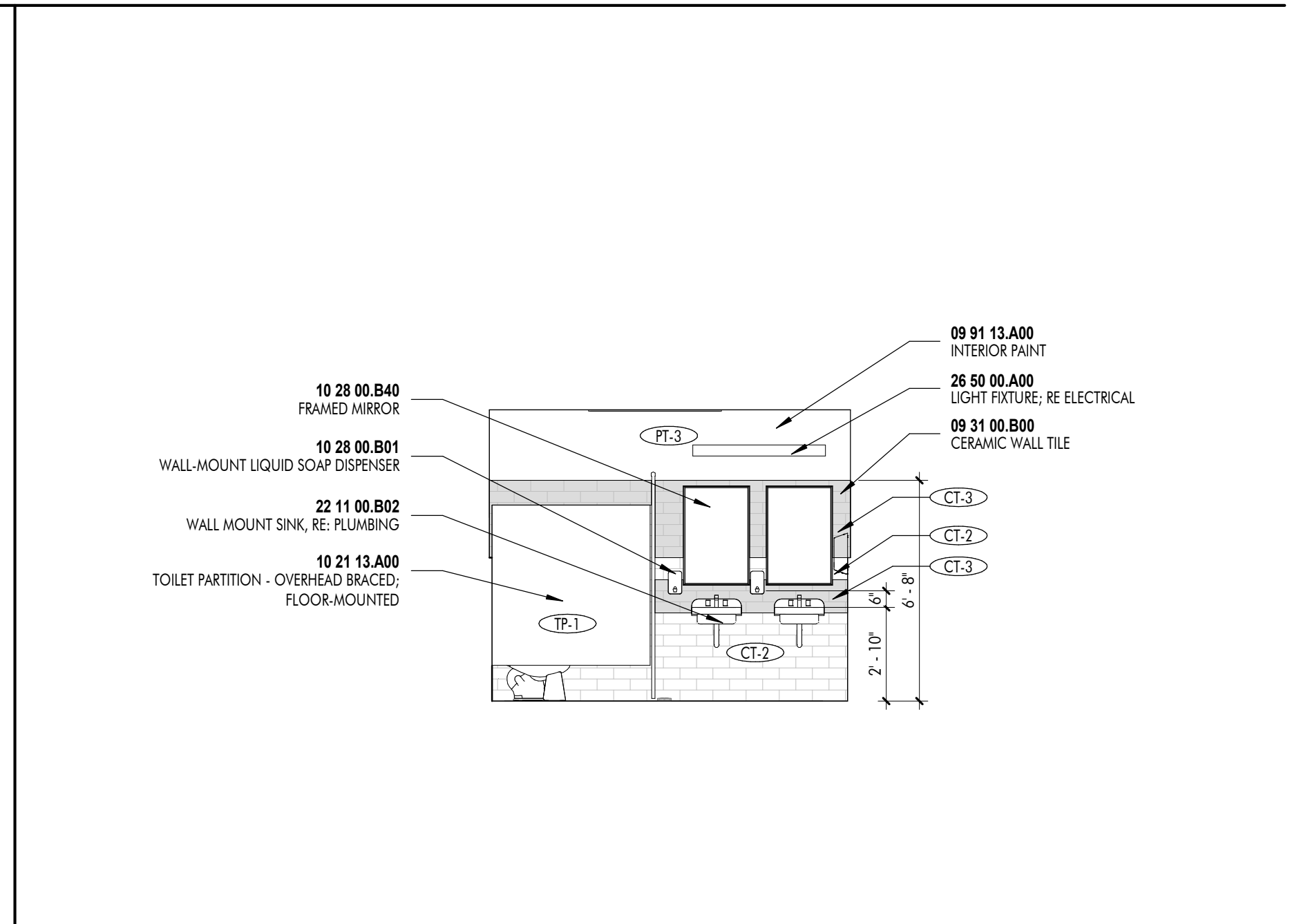
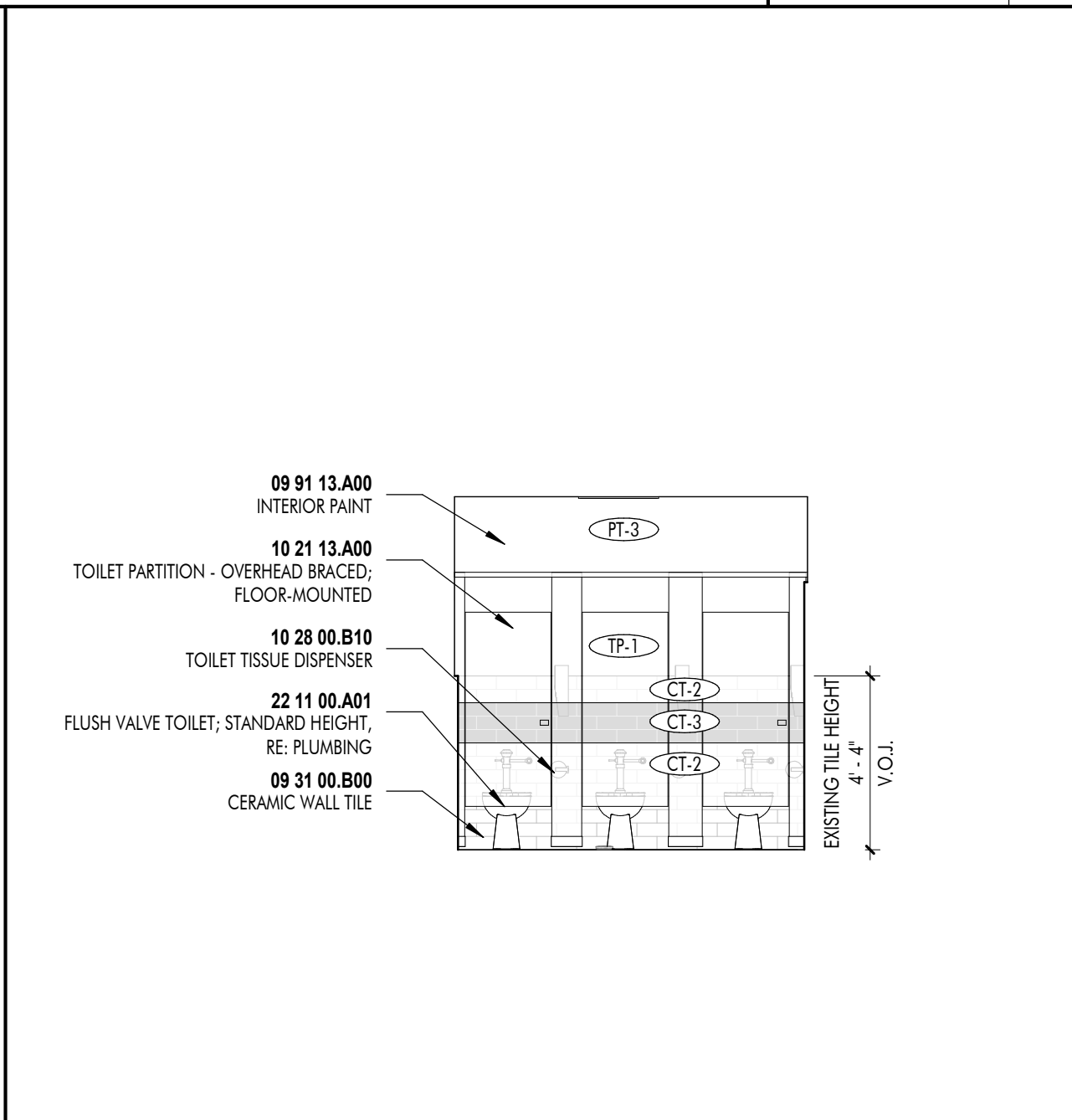
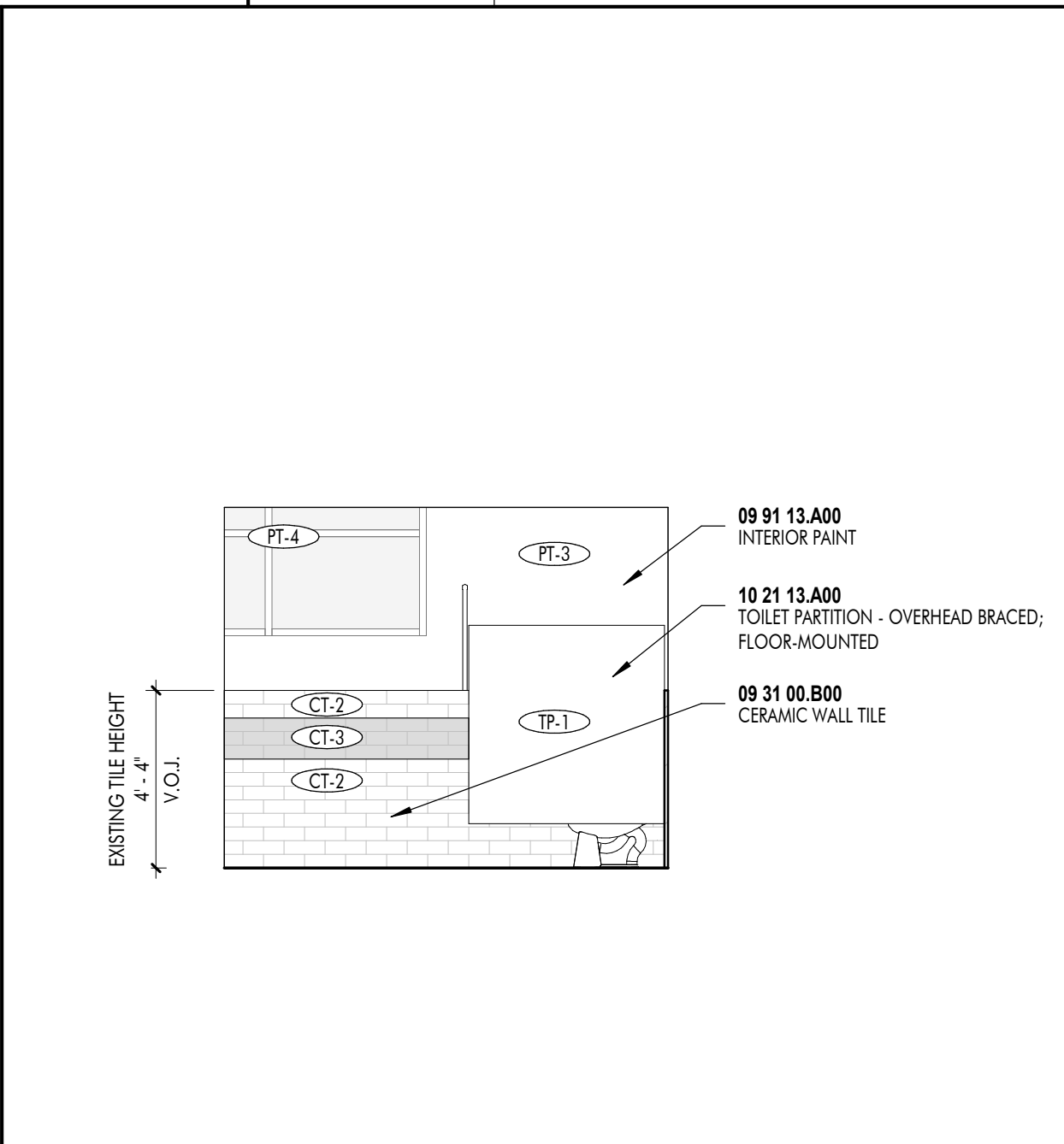
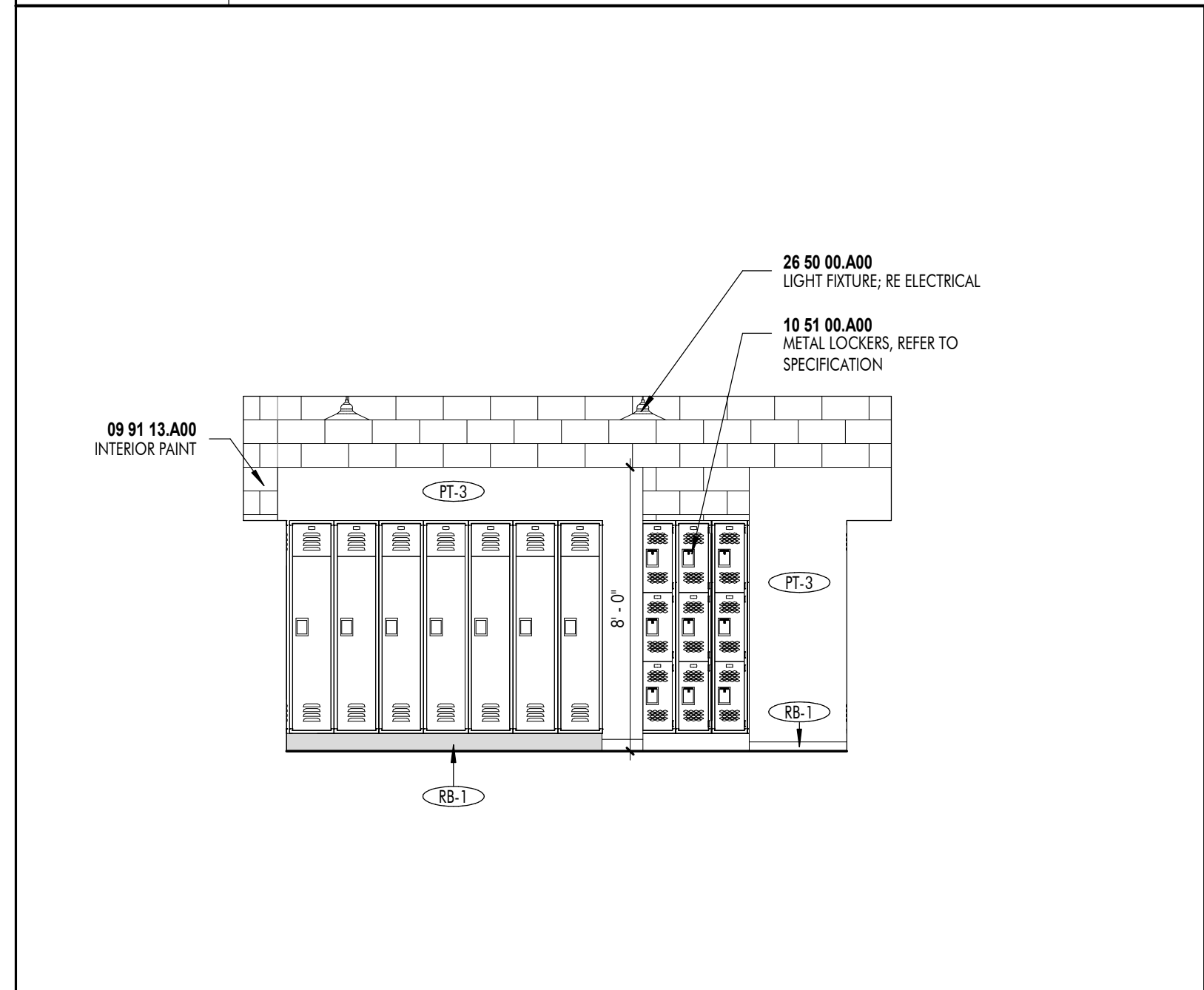

**4** LOCKER ROOM WEST  
1/4" = 1'-0" DRAWN BY: KAS

**5** LOCKER RESTROOM - NORTH  
1/4" = 1'-0" DRAWN BY: KAS

**6** LOCKER - EAST  
1/4" = 1'-0" DRAWN BY: KAS

**7** LOCKER - SOUTH  
1/4" = 1'-0" DRAWN BY: KAS

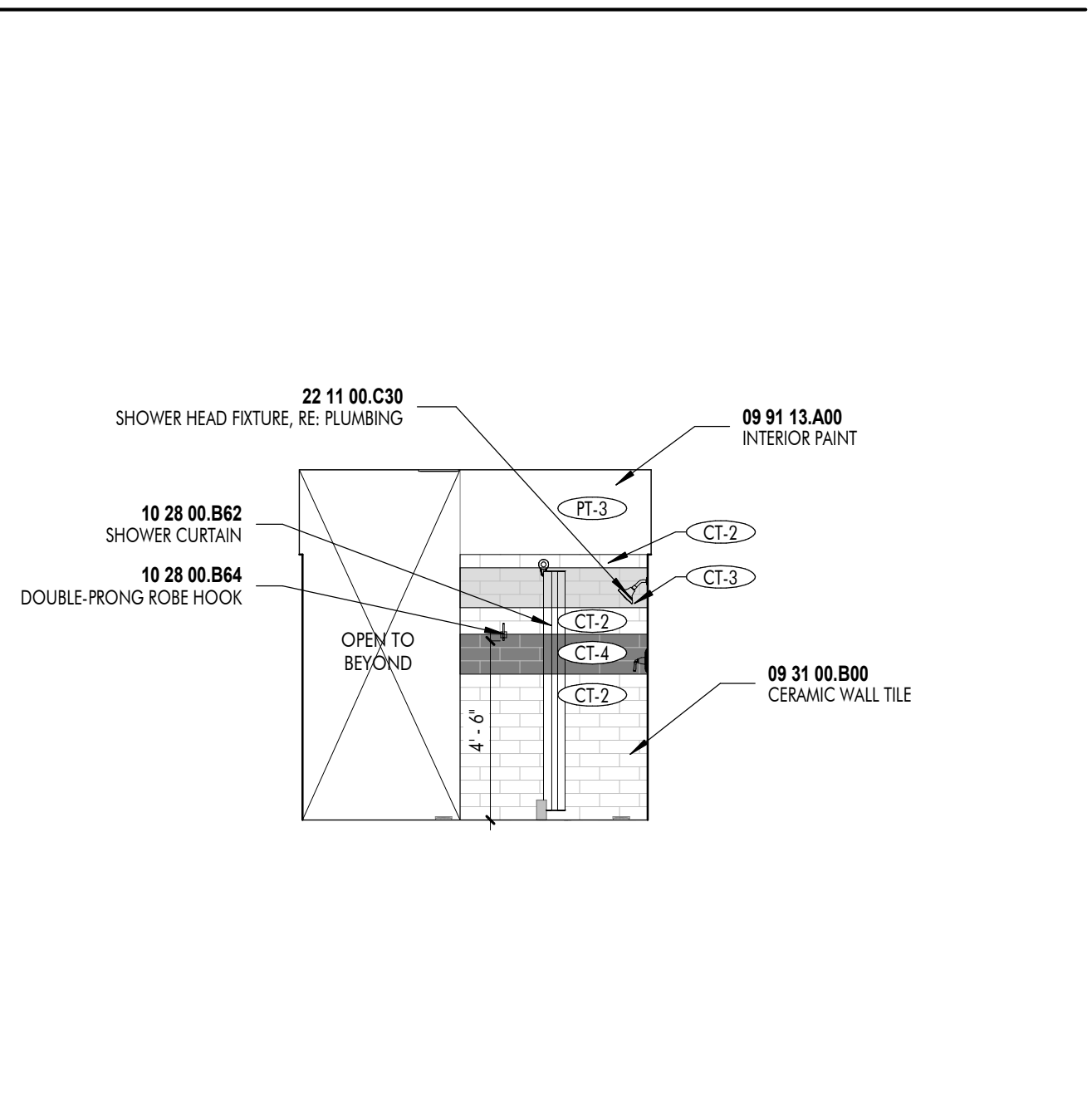
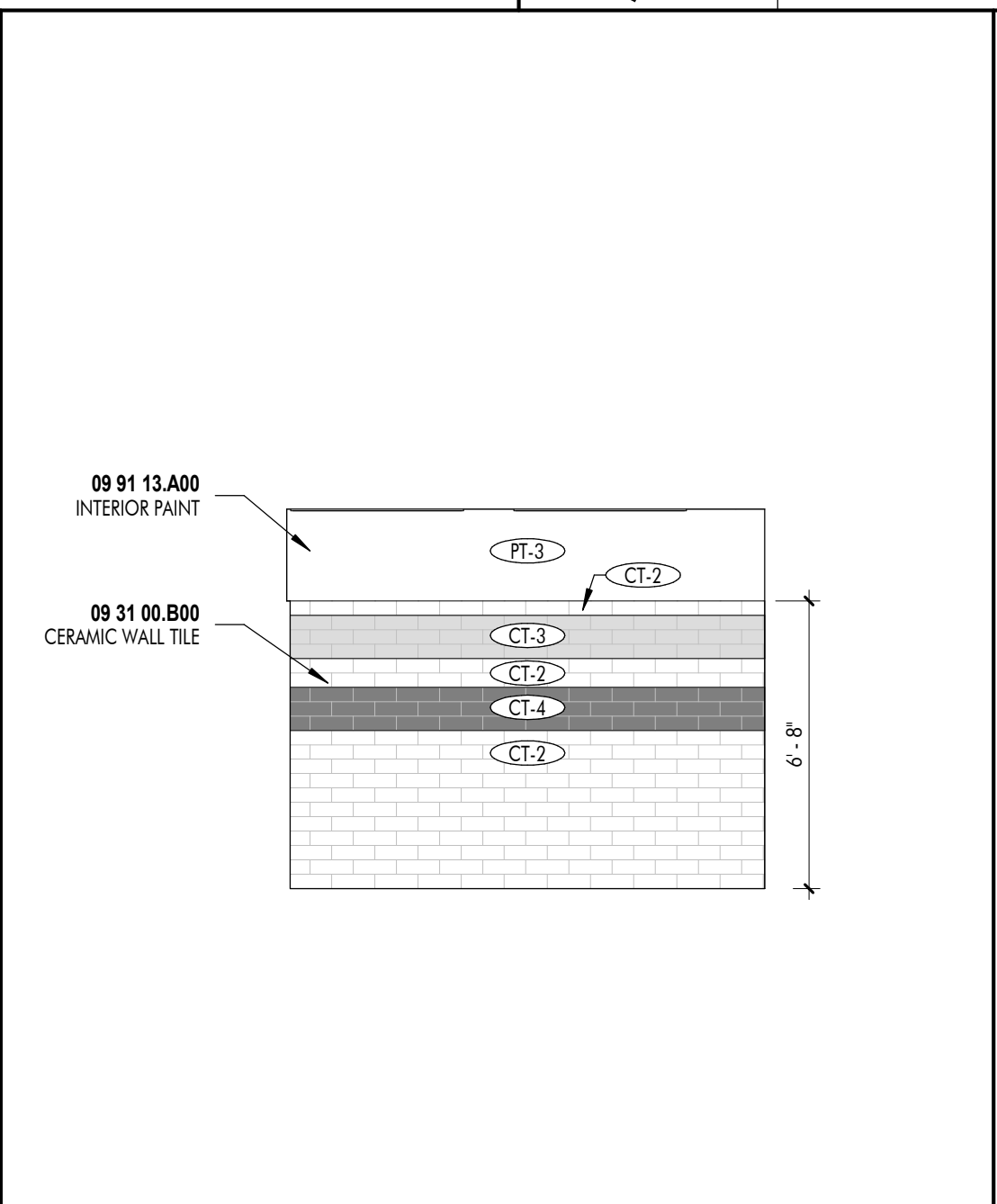
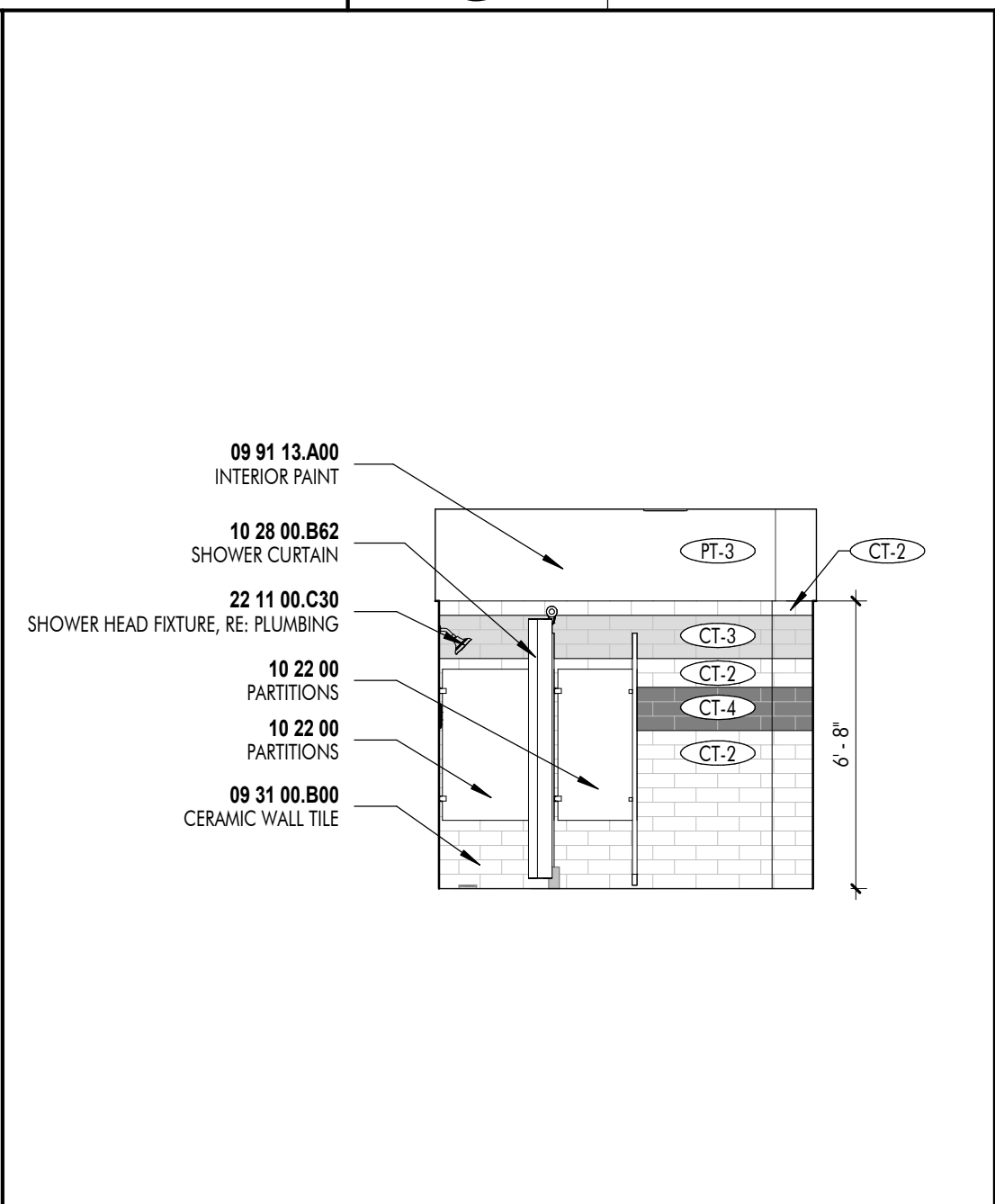
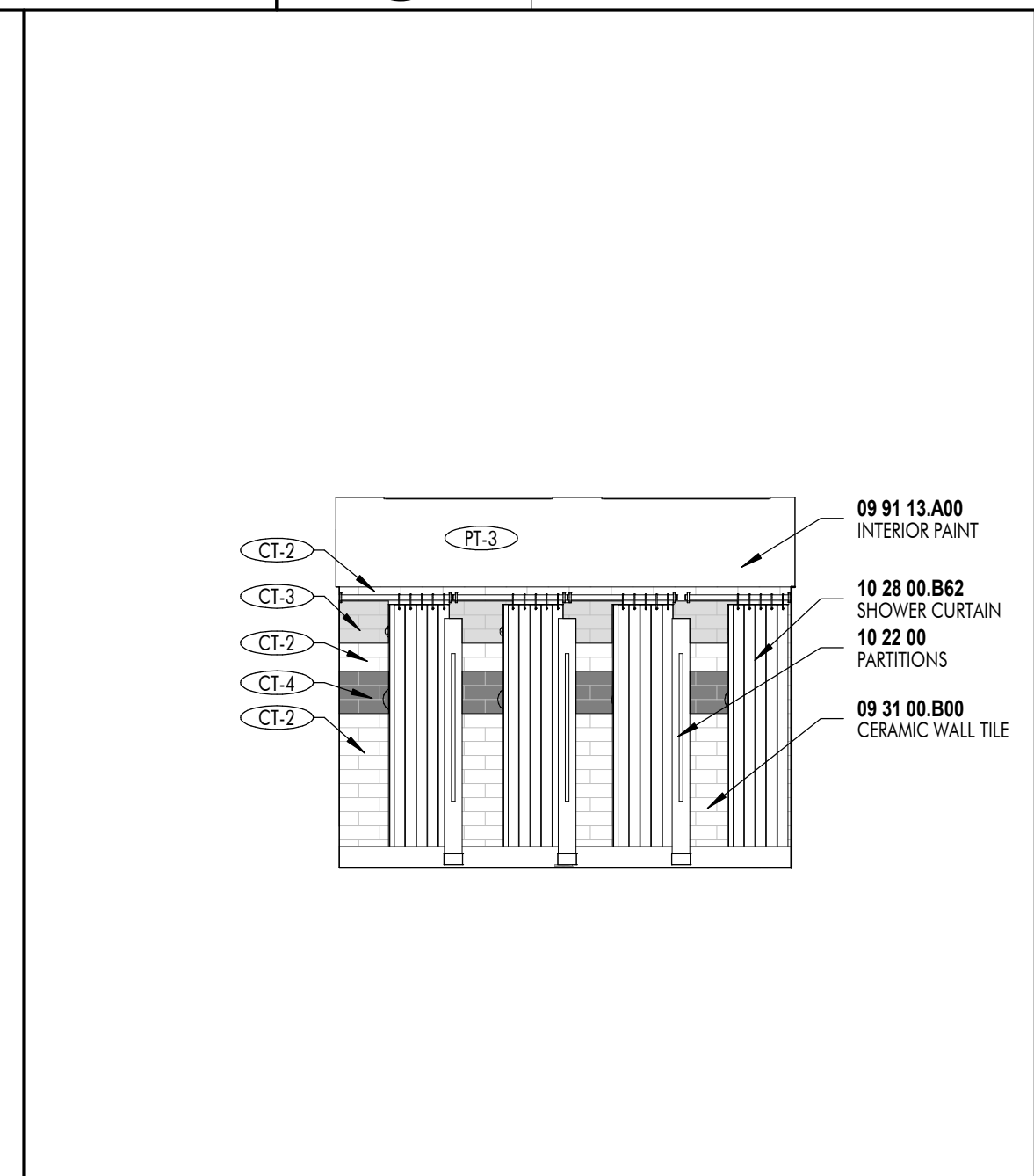
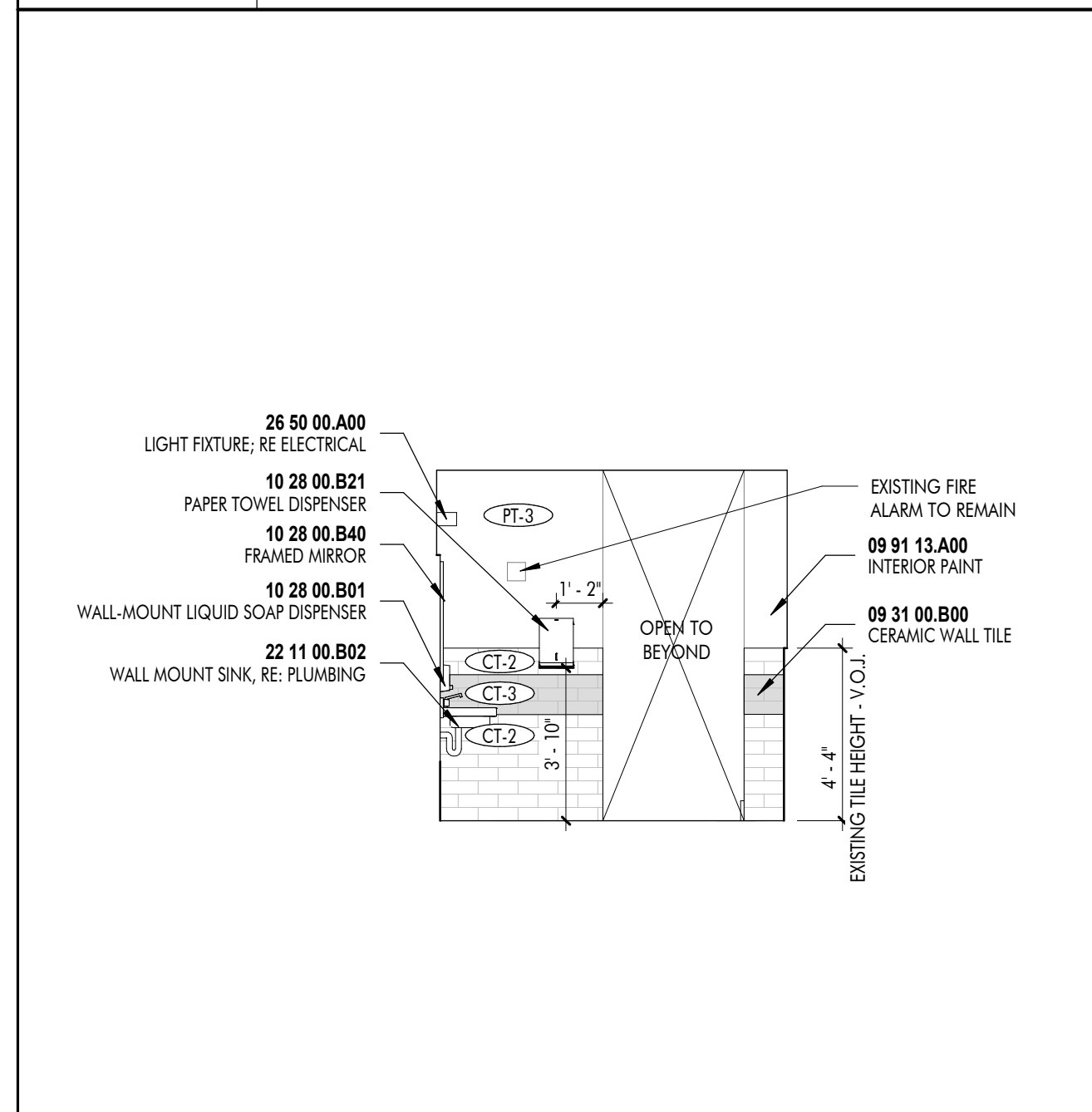

**8** LOCKER - WEST  
1/4" = 1'-0" DRAWN BY: KAS

**9** SHOWER - NORTH  
1/4" = 1'-0" DRAWN BY: KAS

**10** SHOWER - EAST  
1/4" = 1'-0" DRAWN BY: KAS

**11** SHOWER - SOUTH  
1/4" = 1'-0" DRAWN BY: KAS

**12** SHOWER - WEST  
1/4" = 1'-0" DRAWN BY: KAS

AUGUST 31, 2023

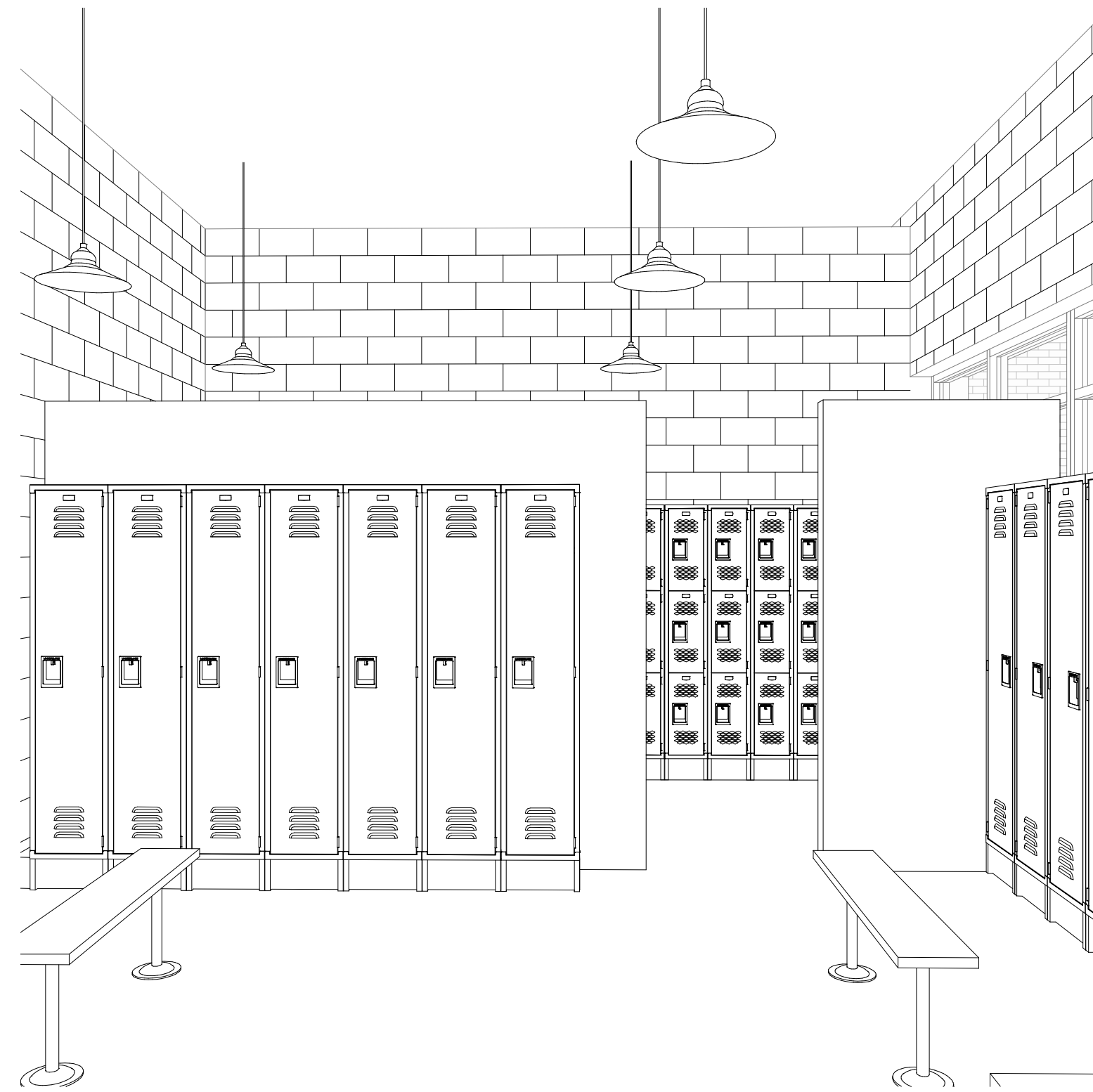
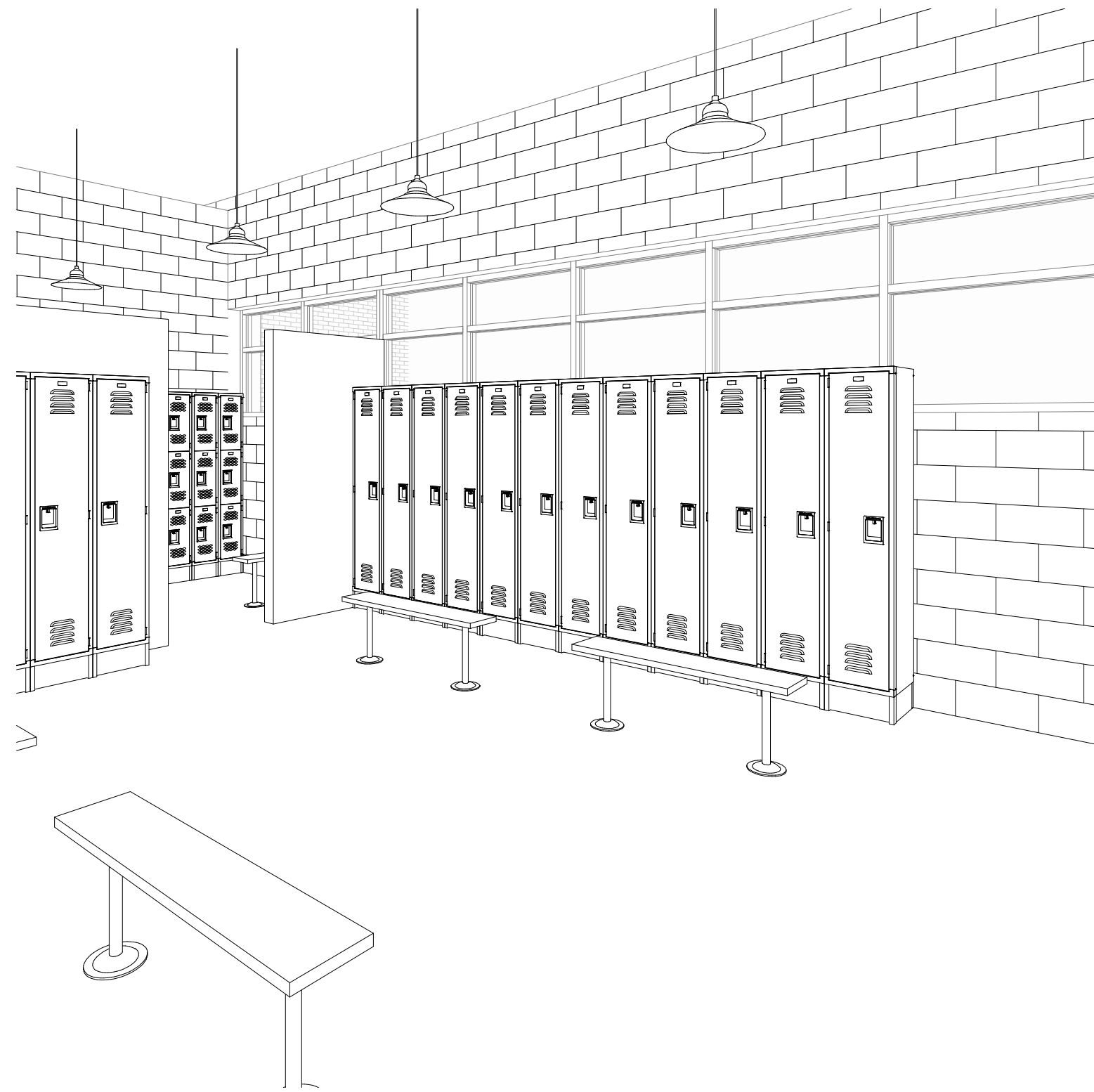
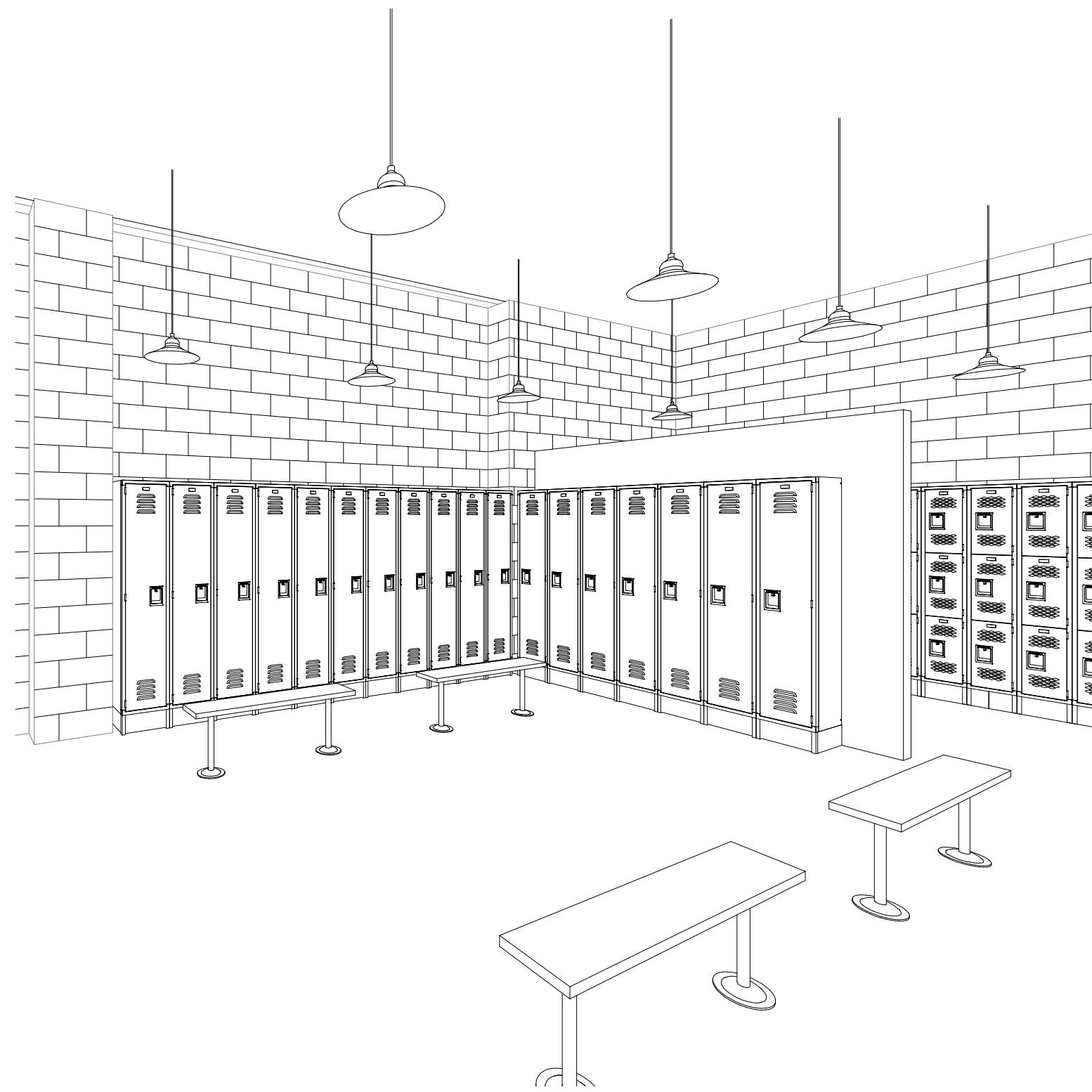
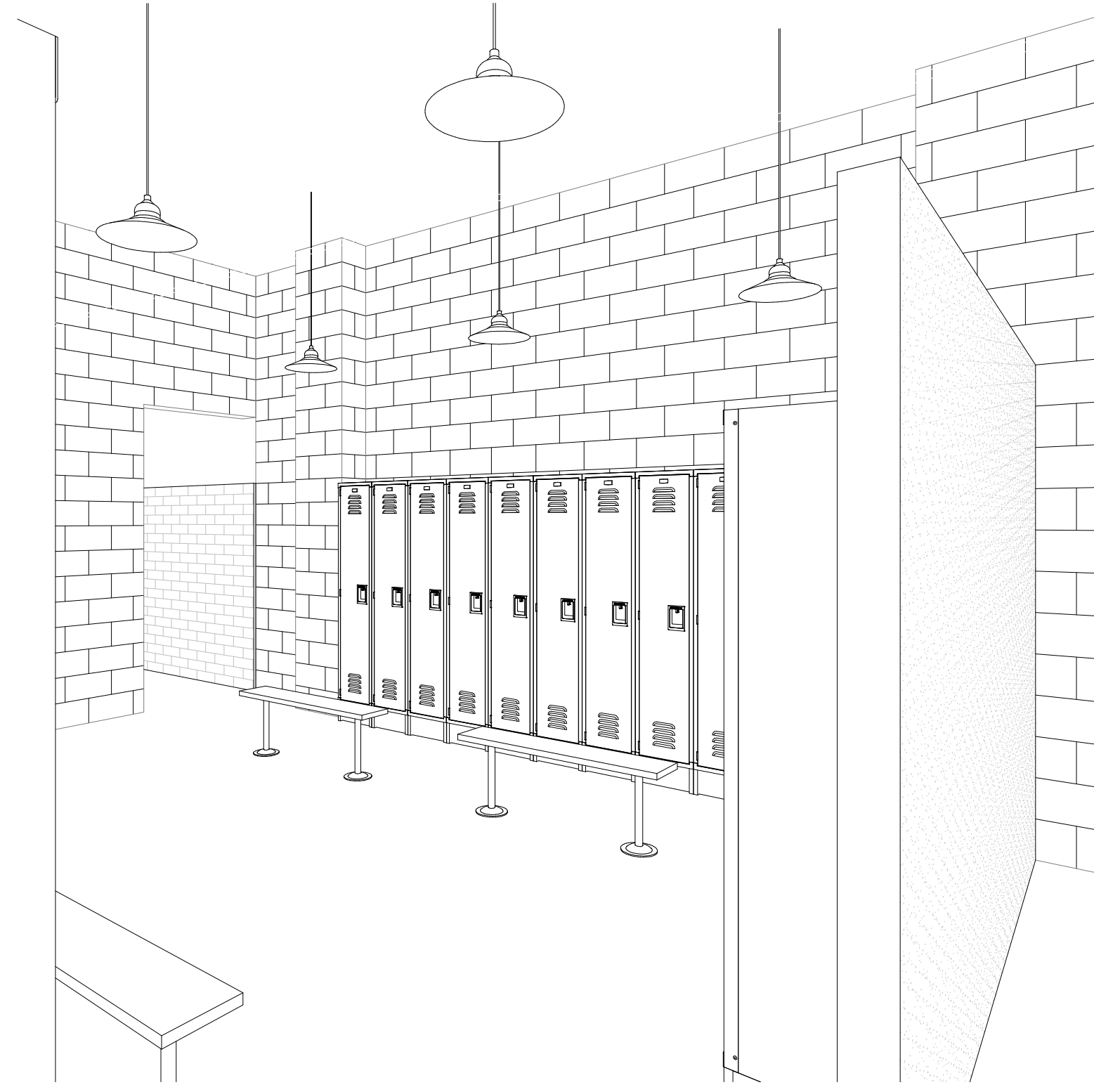
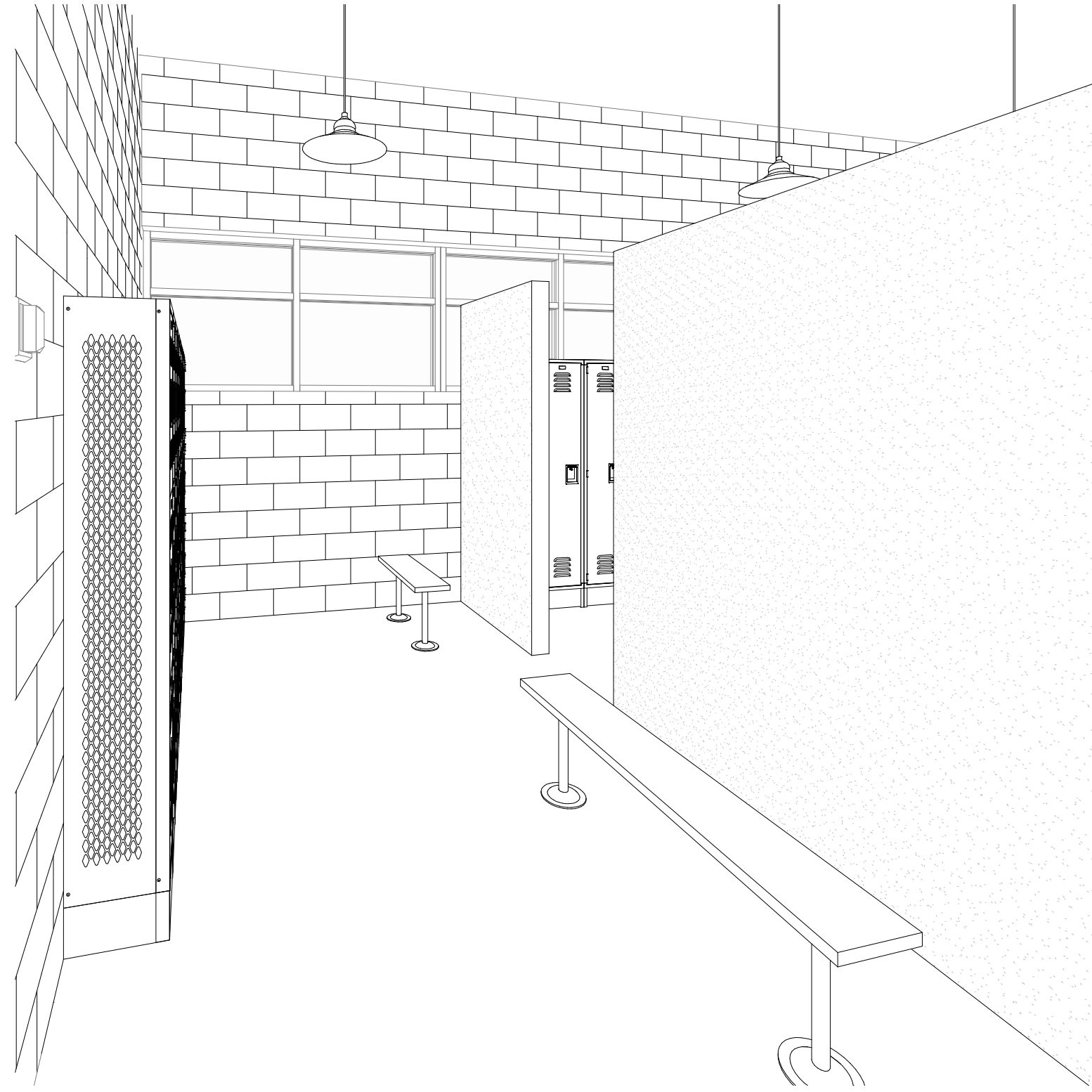

ARCHITECT

**DOMAIN**  
ARCHITECTURE  
APAC

8316 kelwood avenue - baton rouge, la 70806  
t: 225.216.3770 f: 225.216.3771  
www.domain-arch.com

REGISTRATION

These drawings are the property of DOMAIN ARCHITECTURE APAC and are not to be reproduced in whole or in part. They are only to be used for the project and site specifically identified herein. Scales stated herein are valid on the original drawings only. Contractor shall carefully review all dimensions and conditions shown and report to the architect any errors, inconsistencies, or omissions discovered. These plans were prepared in the office under our personal supervision, and to the best of our knowledge comply with state and local codes. We will generally administer construction.

CLIENT

Southern University Laboratory School  
**RESTROOM RENOVATIONS**

129 SWAN AVE,  
BATON ROUGE, LA 70813

PROJECT INFORMATION

revisions	No.	Description	Date

project # **C22-0072**

date **AUGUST 31, 2023**

director review \_\_\_\_\_

**LOCKER ROOM PERSPECTIVES**

**A9.13**

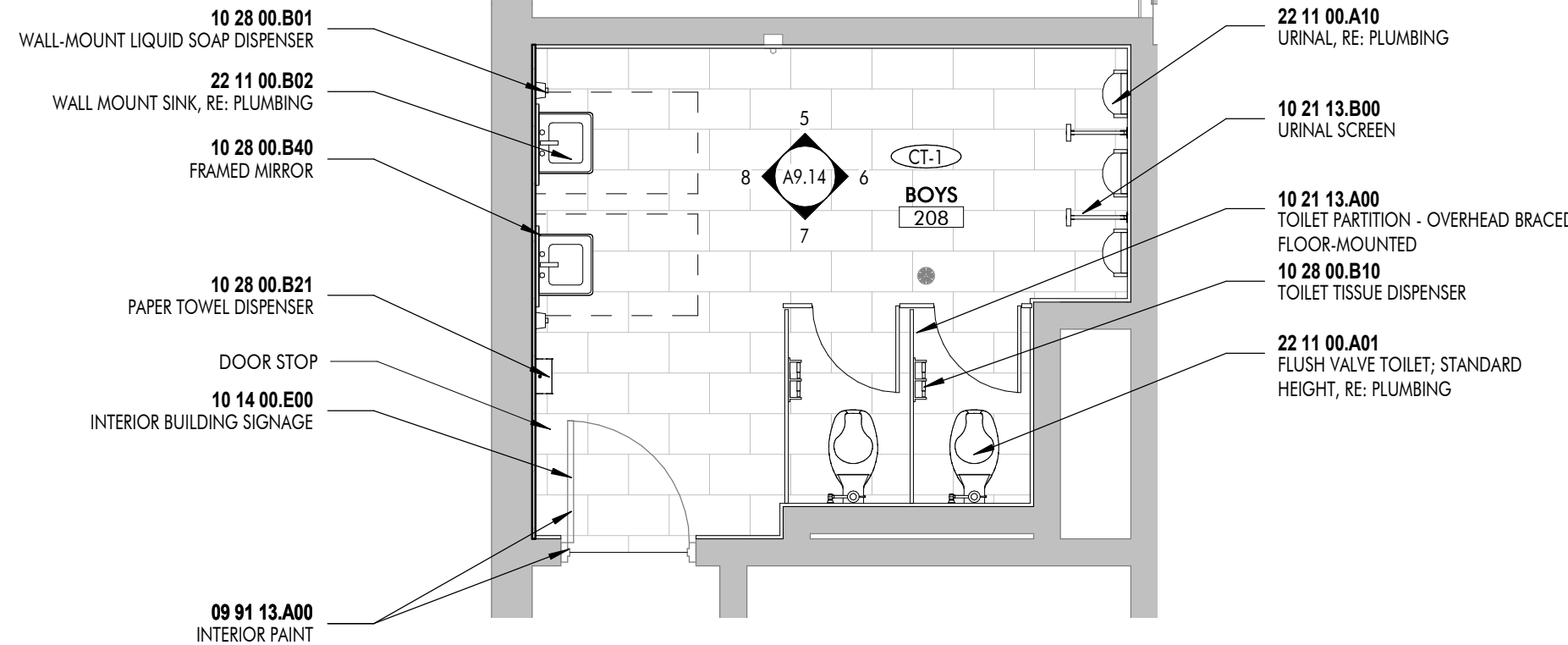
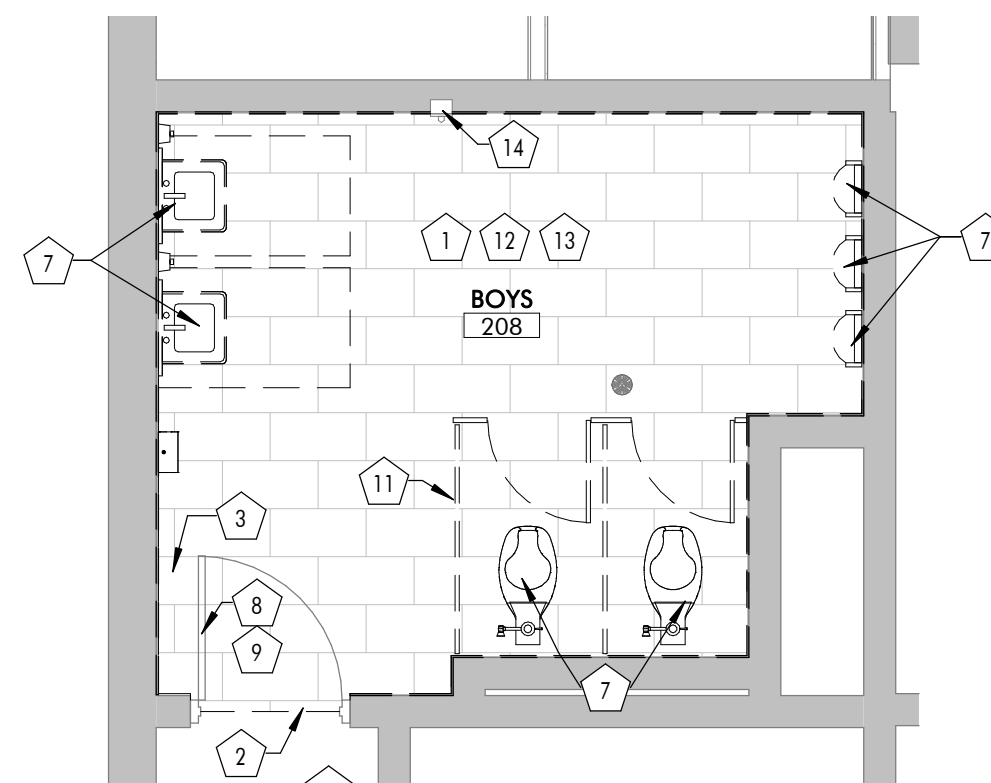

CONSTRUCTION NOTES	
MARK	DESCRIPTION
1	REMOVE EXISTING FLOOR TILE. PATCH AND PREP FLOOR TO RECEIVE NEW TILE AS SCHEDULED. PROVIDE LEVELING COMPOUND AS NECESSARY. MOISTURE TEST EXISTING FLOOR BEFORE NEW FLOOR IS INSTALLED. THOROUGHLY CLEAN EXISTING FLOOR DRAIN.
2	MARBLE THRESHOLD TO BE PROTECTED FOR DURATION OF CONSTRUCTION. THRESHOLD TO BE CLEANED AT END OF CONSTRUCTION.
3	REMOVE DOORSTOP. PATCH AND PREP FLOOR TO RECEIVE NEW DOORSTOP.
4	REMOVE PAINT AND RUST FROM EXISTING STOREFRONT. PREP SURFACE TO RECEIVE NEW PAINT.
5	CONTRACTOR TO ENSURE WALL IS A FINISH LEVEL OF 4. REMOVE ANY FLAKING PAINT. SAND WALL FOR SMOOTH SURFACE AND PREP FOR NEW PAINT.
6	CAREFULLY REMOVE ANY EXISTING INTERIOR SIGNAGE. PATCH AND PREP WALL FOR NEW PAINT.
7	REMOVE EXISTING PLUMBING FIXTURE. MAINTAIN EXISTING PLUMBING FOR REUSE.
8	THOROUGHLY CLEAN DOOR, FRAME AND HARDWARE. RE-CAULK DOOR FRAME. RE: ABATEMENT DRAWINGS.
9	REMOVE EXISTING PAINT ON DOOR AND DOOR FRAME. PREP DOOR AND DOOR FRAME TO RECEIVE NEW PAINT. RE: ABATEMENT DRAWINGS.
10	CAREFULLY REMOVE DOOR, FRAME AND HARDWARE. PREP OPENING FOR NEW DOOR. RE: ABATEMENT DRAWINGS.
11	REMOVE TOILET PARTITIONS. PATCH AND PREP WALL FOR NEW PAINT.
12	REMOVE ALL EXISTING RESTROOM ACCESSORIES. (INCLUDING BUT NOT LIMITED TO MIRROR, TOILET PAPER HOLDER, GRAB BARS, SOAP DISPENSER, PAPER TOWEL DISPENSER, TOILET CLEANER)
13	CAREFULLY REMOVE EXISTING TILE ON WALLS. PATCH AND PREP WALL TO RECEIVE NEW TILE.
14	MAINTAIN AND PROTECT FIRE ALARM AND ALL RELATED CONDUIT.
15	CONTRACTOR TO ENSURE CEILING IS A FINISH LEVEL OF 4. REMOVE ANY FLAKING PAINT. SAND CEILING FOR SMOOTH SURFACE AND PREP FOR NEW PAINT.
16	REMOVE EXISTING RADIATOR AND ALL ACCESSORIES ASSOCIATED WITH IT. PATCH AND PREP WALL.
17	PATCH HOLE IN THE WALL. PREP SURFACE TO RECEIVE NEW TILE.
18	REMOVE EXISTING LOCKERS.
19	REMOVE CONCRETE CURB. PROTECT SURROUNDING CONCRETE.
20	REMOVE EXISTING BENCH. PATCH AND PREP CONCRETE TO RECEIVE NEW SEAL.
21	REMOVE CEILING TILE AND GRID. PATCH AND PREP WALL TO RECEIVE NEW CEILING.
22	CAREFULLY REMOVE AND SALVAGE SUPPLY VENT FOR REUSE. REMOVE ANY PAINT FROM SURFACE AND CLEAN THOROUGHLY.
23	CAREFULLY REMOVE AND SALVAGE RETURN VENT FOR REUSE. REMOVE ANY PAINT FROM SURFACE AND CLEAN THOROUGHLY.
24	CAREFULLY REMOVE AND SALVAGE EXHAUST FAN FOR REUSE. REMOVE ANY PAINT FROM SURFACE AND CLEAN THOROUGHLY.
25	CAREFULLY REMOVE SURFACE MOUNTED LIGHT FIXTURE. ELECTRICAL TO REMAIN FOR REUSE.
26	REMOVE ALL LIGHT FIXTURES FROM ENTIRE ROOM. ELECTRICAL TO REMAIN FOR REUSE. CAP ANY ELECTRICAL NOT REUSED.
27	CAREFULLY REMOVE HANGING LIGHT FIXTURE. ELECTRICAL TO REMAIN FOR REUSE.
28	PREP PLASTER CEILING TO RECEIVE NEW PAINT.
29	PREP METAL CEILING TO RECEIVE NEW PAINT.
30	REMOVE DOOR, FRAME AND HARDWARE. PREPARE OPENING TO BE INFILLED.
31	REMOVE PORTION OF EXISTING WALL TO RECEIVE NEW DOOR.
A	MAIN STAGING AREA FOR CONTRACTOR
B	SUB-STAGING / PARKING AREA
C	STAGING AREAS SHALL BE REGRADED AND SEEDED WHEN THE CONSTRUCTION PROJECT HAS BEEN COMPLETED.
D	STAGING AREAS MUST BE FENCED AND LOCKABLE ALL TIMES.

**1** 2ND FLOOR BOYS - DEMOLITION FLOOR PLAN  
1/4" = 1'-0" DRAWN BY: KAS

**2** 2ND FLOOR BOYS - NEW CONSTRUCTION FLOOR PLAN  
1/4" = 1'-0" DRAWN BY: KAS

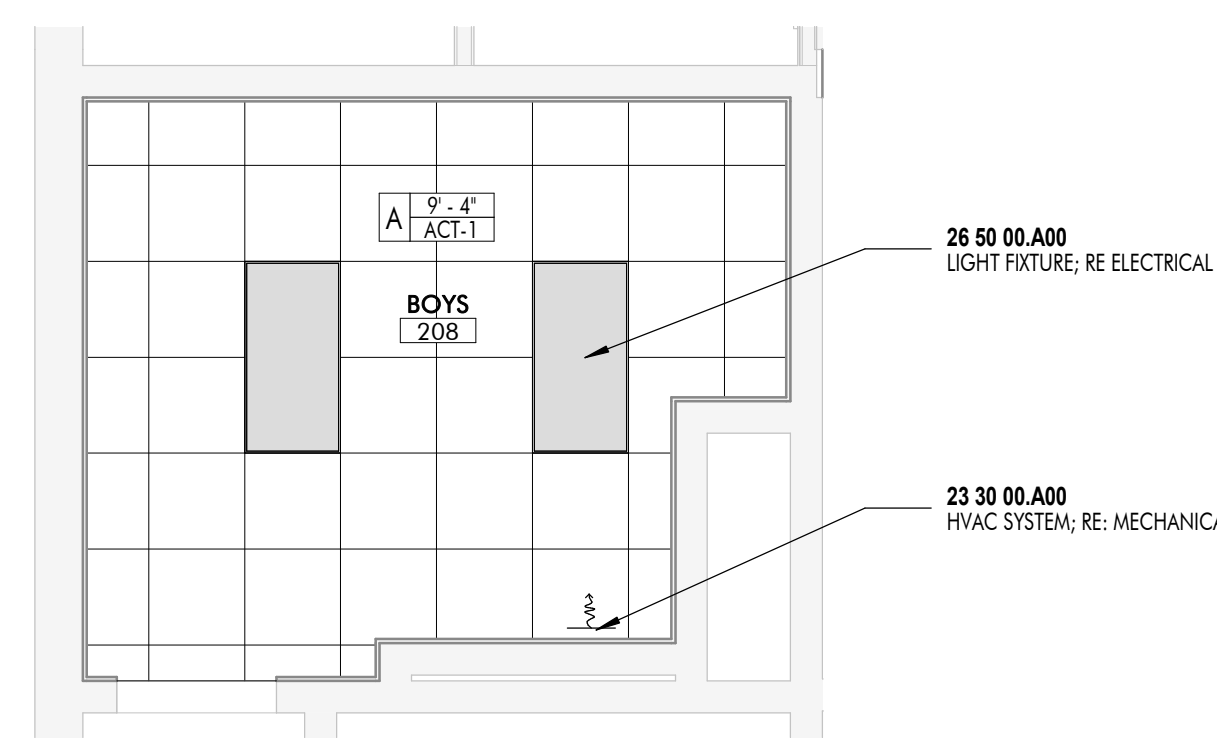

**3** 2ND FLOOR BOYS - DEMOLITION RCP  
1/4" = 1'-0" DRAWN BY: KAS

**4** 2ND FLOOR BOYS - NEW CONSTRUCTION RCP  
1/4" = 1'-0" DRAWN BY: KAS

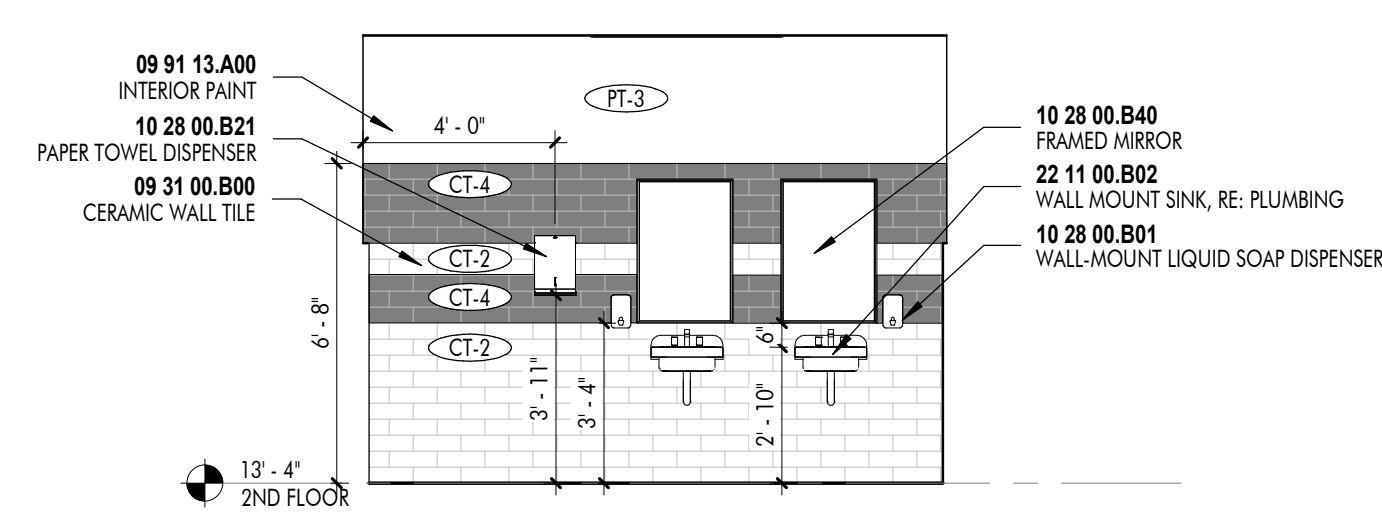
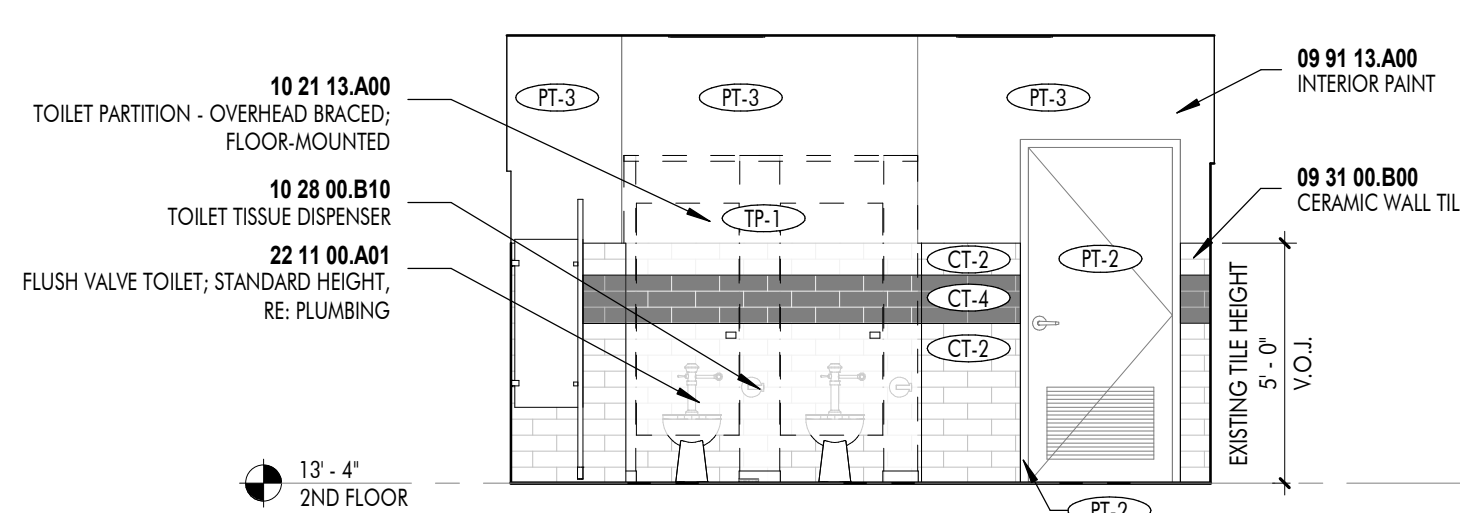
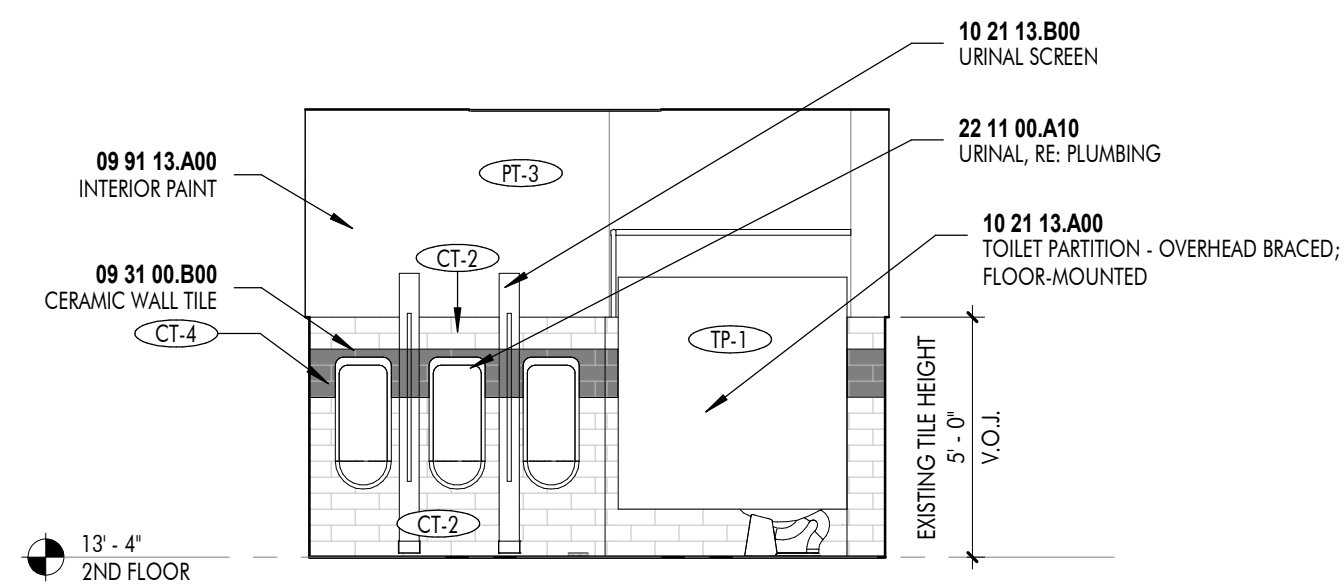
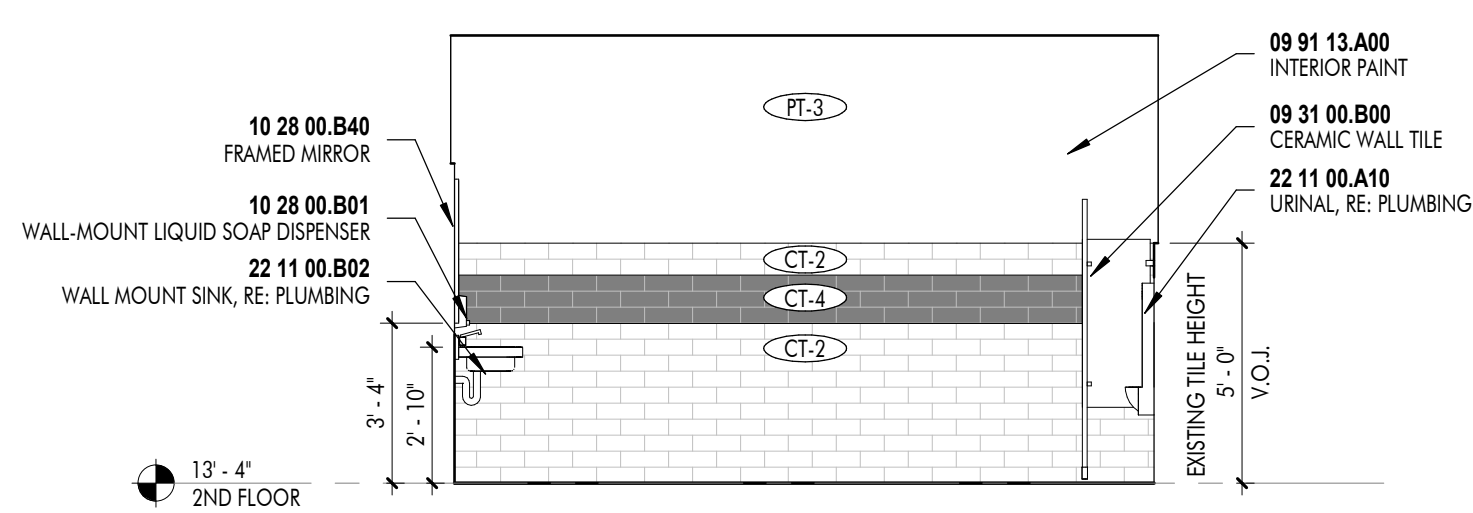

**5** 2ND FLOOR BOYS - NORTH  
1/4" = 1'-0" DRAWN BY: KAS

**6** 2ND FLOOR BOYS - EAST  
1/4" = 1'-0" DRAWN BY: KAS

**7** 2ND FLOOR BOYS - SOUTH  
1/4" = 1'-0" DRAWN BY: KAS

**8** 2ND FLOOR BOYS - WEST  
1/4" = 1'-0" DRAWN BY: KAS

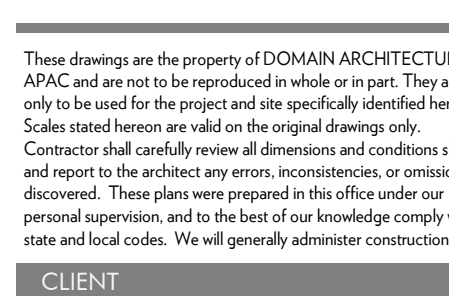

Southern University Laboratory School  
**RESTROOM RENOVATIONS**  
129 SWAN AVE,  
BATON ROUGE, LA 70813

PROJECT INFORMATION	
revisions	Date
No.	Description
project # C22-0072	
date AUGUST 31, 2023	
director review	

2ND FLOOR BOYS  
**A9.14**

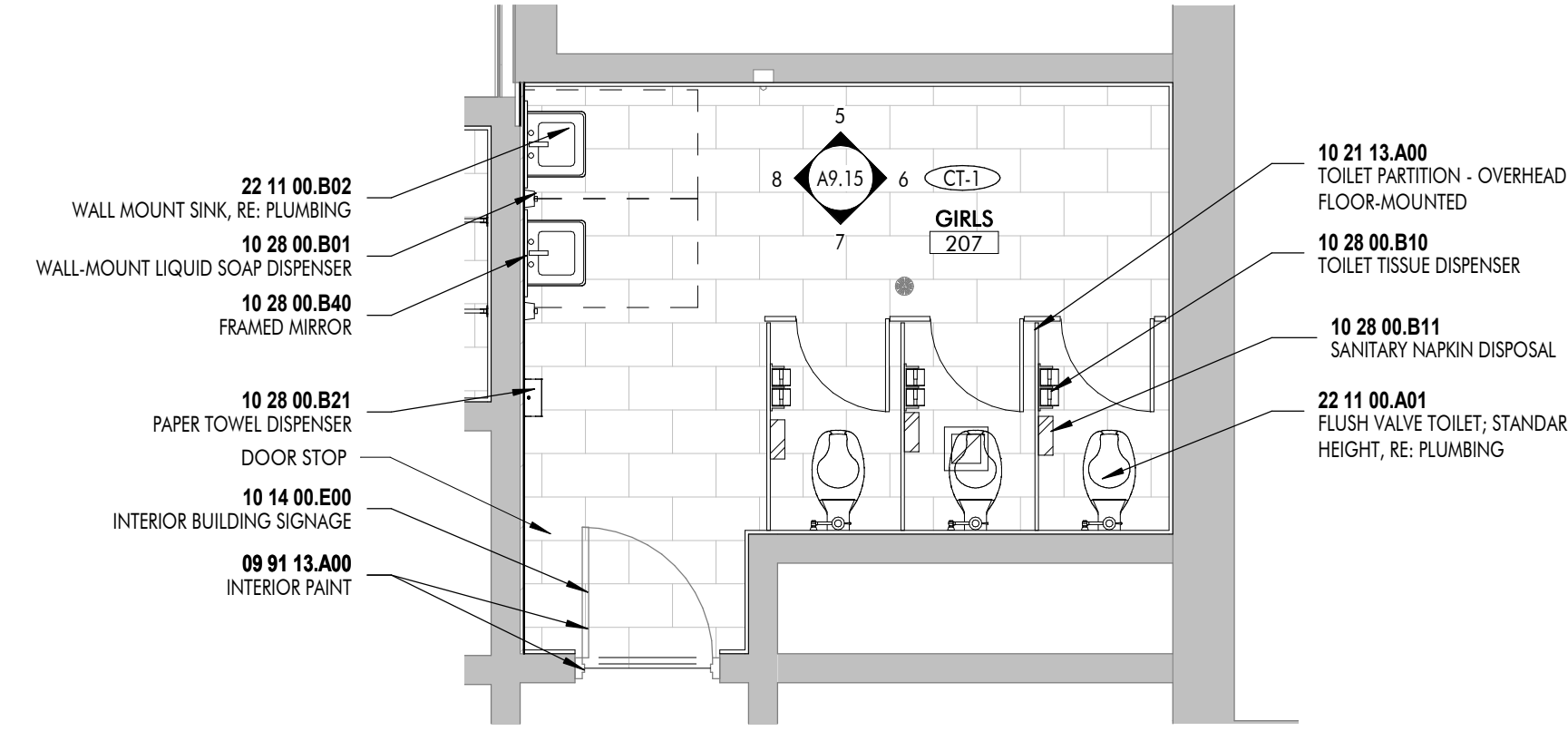
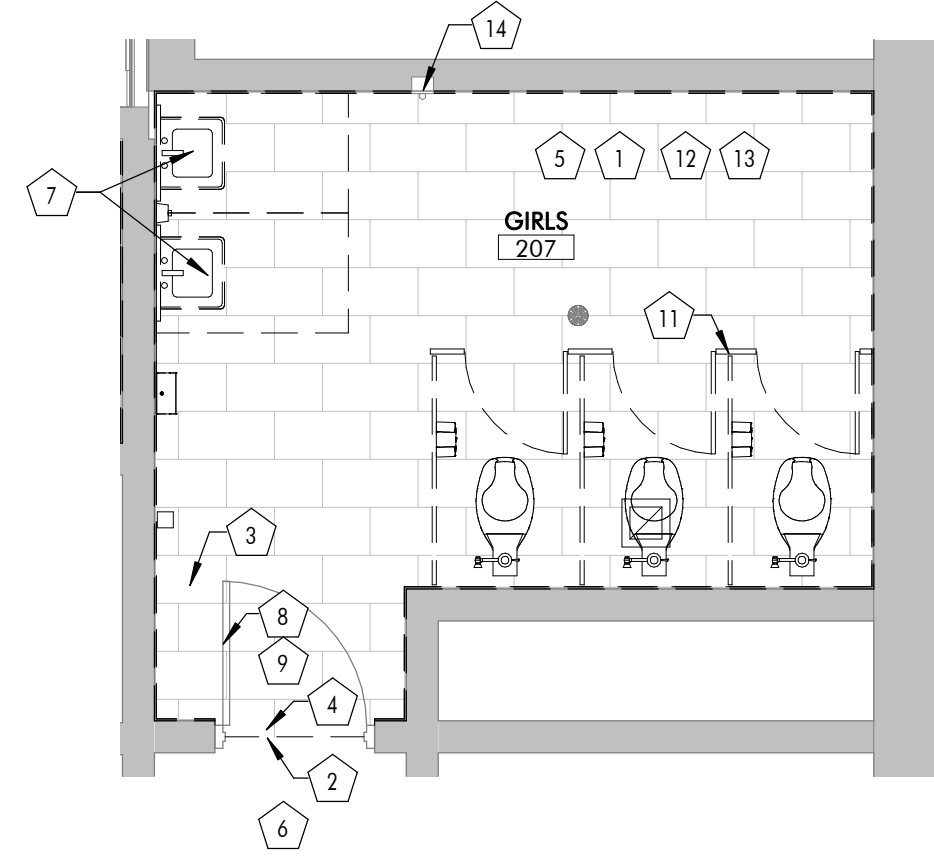

CONSTRUCTION NOTES	
MARK	DESCRIPTION
1	REMOVE EXISTING FLOOR TILE. PATCH AND PREP FLOOR TO RECEIVE NEW TILE AS SCHEDULED. PROVIDE LEVELING COMPOUND AS NECESSARY. MOISTURE TEST EXISTING FLOOR BEFORE NEW FLOOR IS INSTALLED. THOROUGHLY CLEAN EXISTING FLOOR DRAIN.
2	MARBLE THRESHOLD TO BE PROTECTED FOR DURATION OF CONSTRUCTION. THRESHOLD TO BE CLEANED AT END OF CONSTRUCTION.
3	REMOVE DOORSTOP. PATCH AND PREP FLOOR TO RECEIVE NEW DOORSTOP.
4	REMOVE PAINT AND RUST FROM EXISTING STOREFRONT. PREP SURFACE TO RECEIVE NEW PAINT.
5	CONTRACTOR TO ENSURE WALL IS A FINISH LEVEL OF 4. REMOVE ANY FLAKING PAINT. SAND WALL FOR SMOOTH SURFACE AND PREP FOR NEW PAINT.
6	CAREFULLY REMOVE ANY EXISTING INTERIOR SIGNAGE. PATCH AND PREP WALL FOR NEW PAINT.
7	REMOVE EXISTING PLUMBING FIXTURE. MAINTAIN EXISTING PLUMBING FOR REUSE.
8	THOROUGHLY CLEAN DOOR, FRAME AND HARDWARE. RE-CAULK DOOR FRAME. RE: ABATEMENT DRAWINGS.
9	REMOVE EXISTING PAINT ON DOOR AND DOOR FRAME. PREP DOOR AND DOOR FRAME TO RECEIVE NEW PAINT. RE: ABATEMENT DRAWINGS.
10	CAREFULLY REMOVE DOOR, FRAME AND HARDWARE. PREP OPENING FOR NEW DOOR. RE: ABATEMENT DRAWINGS.
11	REMOVE TOILET PARTITIONS. PATCH AND PREP WALL FOR NEW PAINT.
12	REMOVE ALL EXISTING RESTROOM ACCESSORIES. (INCLUDING BUT NOT LIMITED TO MIRROR, TOILET PAPER HOLDER, GRAB BARS, SOAP DISPENSER, PAPER TOWEL DISPENSER, TOILET CLEANER)
13	CAREFULLY REMOVE EXISTING TILE ON WALLS. PATCH AND PREP WALL TO RECEIVE NEW TILE.
14	MAINTAIN AND PROTECT FIRE ALARM AND ALL RELATED CONDUIT.
15	CONTRACTOR TO ENSURE CEILING IS A FINISH LEVEL OF 4. REMOVE ANY FLAKING PAINT. SAND CEILING FOR SMOOTH SURFACE AND PREP FOR NEW PAINT.
16	REMOVE EXISTING RADIATOR AND ALL ACCESSORIES ASSOCIATED WITH IT. PATCH AND PREP WALL.
17	PATCH HOLE IN THE WALL. PREP SURFACE TO RECEIVE NEW TILE.
18	REMOVE EXISTING LOCKERS.
19	REMOVE CONCRETE CURB. PROTECT SURROUNDING CONCRETE.
20	REMOVE EXISTING BENCH. PATCH AND PREP CONCRETE TO RECEIVE NEW SEAL.
21	REMOVE CEILING TILE AND GRID. PATCH AND PREP WALL TO RECEIVE NEW CEILING.
22	CAREFULLY REMOVE AND SALVAGE SUPPLY VENT FOR REUSE. REMOVE ANY PAINT FROM SURFACE AND CLEAN THOROUGHLY.
23	CAREFULLY REMOVE AND SALVAGE RETURN VENT FOR REUSE. REMOVE ANY PAINT FROM SURFACE AND CLEAN THOROUGHLY.
24	CAREFULLY REMOVE AND SALVAGE EXHAUST FAN FOR REUSE. REMOVE ANY PAINT FROM SURFACE AND CLEAN THOROUGHLY.
25	CAREFULLY REMOVE SURFACE MOUNTED LIGHT FIXTURE. ELECTRICAL TO REMAIN FOR REUSE.
26	REMOVE ALL LIGHT FIXTURES FROM ENTIRE ROOM. ELECTRICAL TO REMAIN FOR REUSE. CAP ANY ELECTRICAL NOT REUSED.
27	CAREFULLY REMOVE HANGING LIGHT FIXTURE. ELECTRICAL TO REMAIN FOR REUSE.
28	PREP PLASTER CEILING TO RECEIVE NEW PAINT.
29	PREP METAL CEILING TO RECEIVE NEW PAINT.
30	REMOVE DOOR, FRAME AND HARDWARE. PREPARE OPENING TO BE INFILLED.
31	REMOVE PORTION OF EXISTING WALL TO RECEIVE NEW DOOR.
A	MAIN STAGING AREA FOR CONTRACTOR
B	SUB-STAGING / PARKING AREA
C	STAGING AREAS SHALL BE REGRADED AND SEEDED WHEN THE CONSTRUCTION PROJECT HAS BEEN COMPLETED.
D	STAGING AREAS MUST BE FENCED AND LOCKABLE ALL TIMES.

**1** 2ND FLOOR GIRLS - DEMOLITION PLAN  
1/4" = 1'-0" DRAWN BY: KAS

**2** 2ND FLOOR GIRLS - NEW CONSTRUCTION  
1/4" = 1'-0" DRAWN BY: KAS

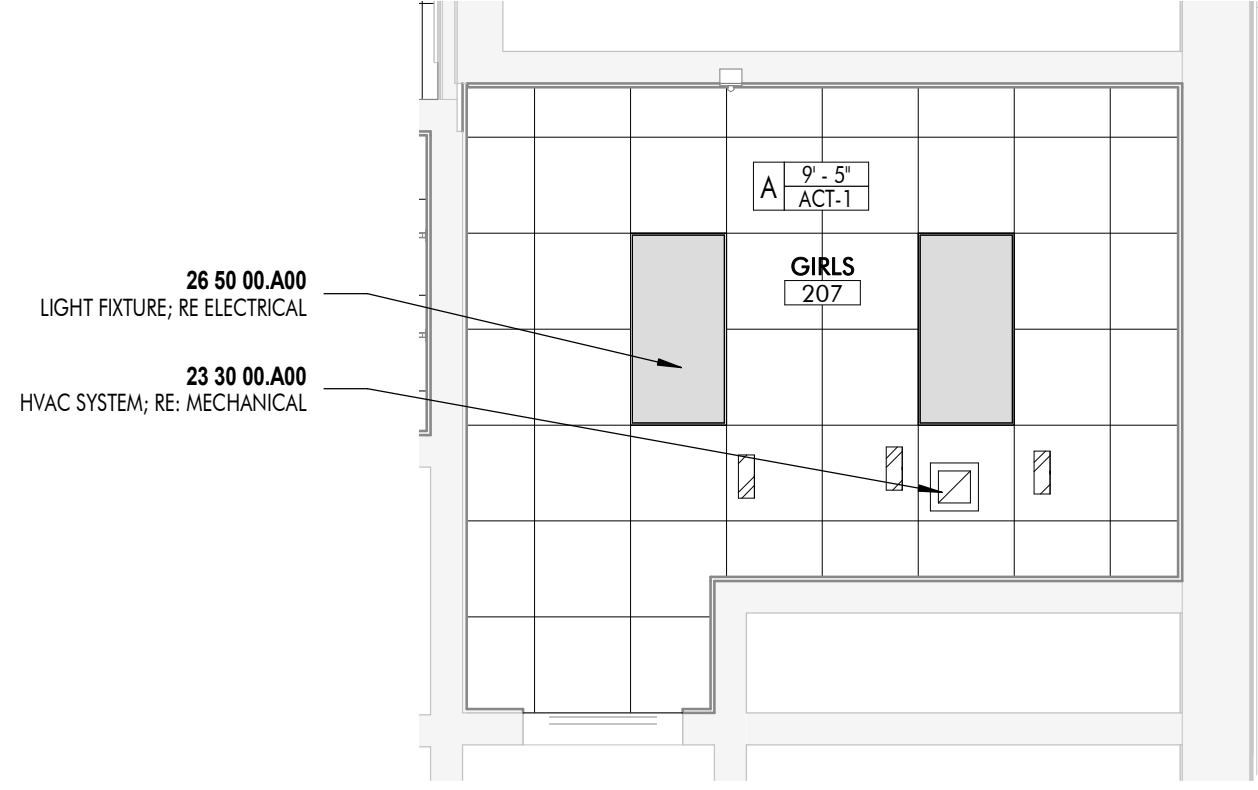

**3** 2ND FLOOR GIRLS - DEMOLITION RCP  
1/4" = 1'-0" DRAWN BY: KAS

**4** 2ND FLOOR GIRLS - NEW CONSTRUCTION RCP  
1/4" = 1'-0" DRAWN BY: KAS

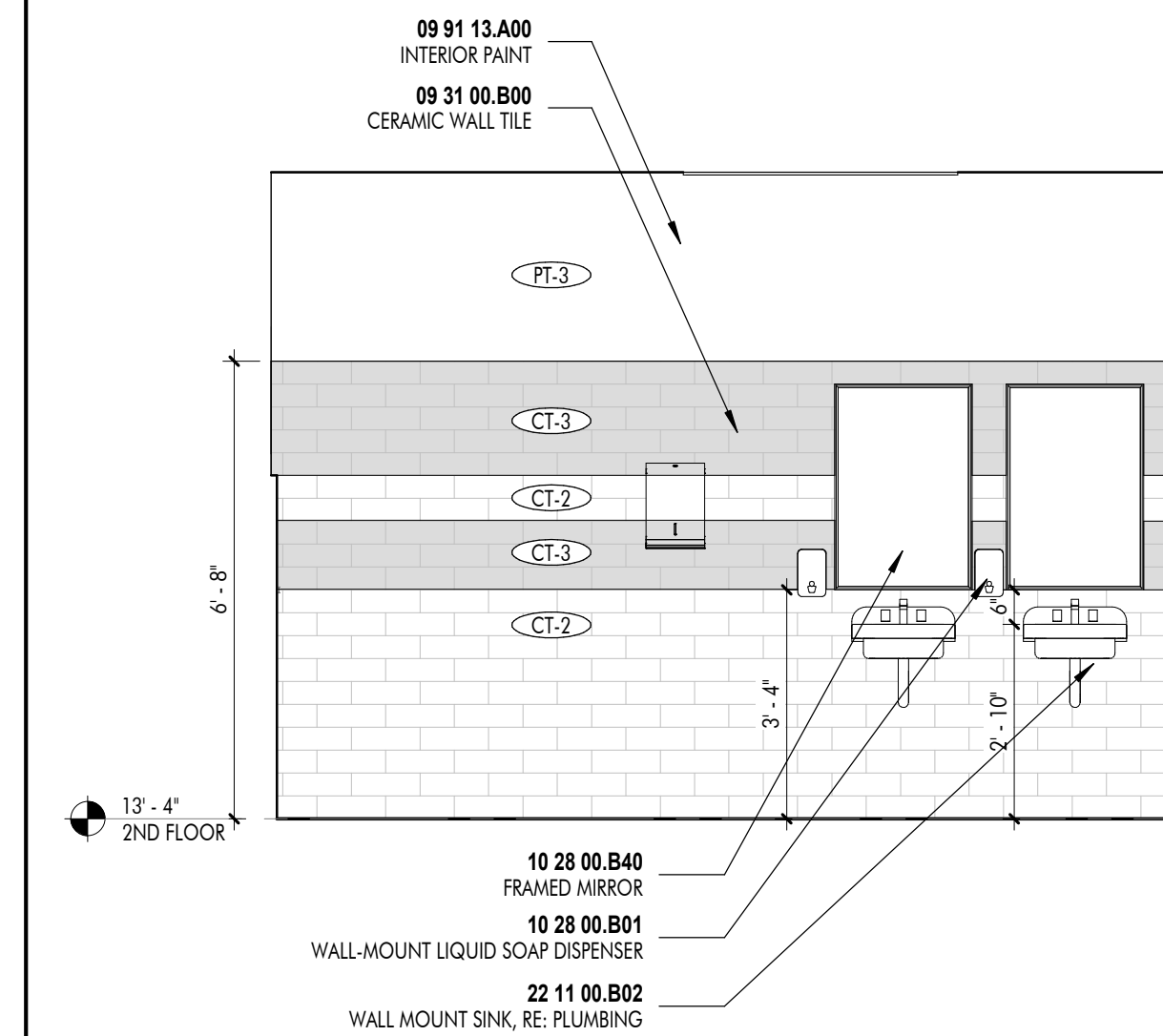
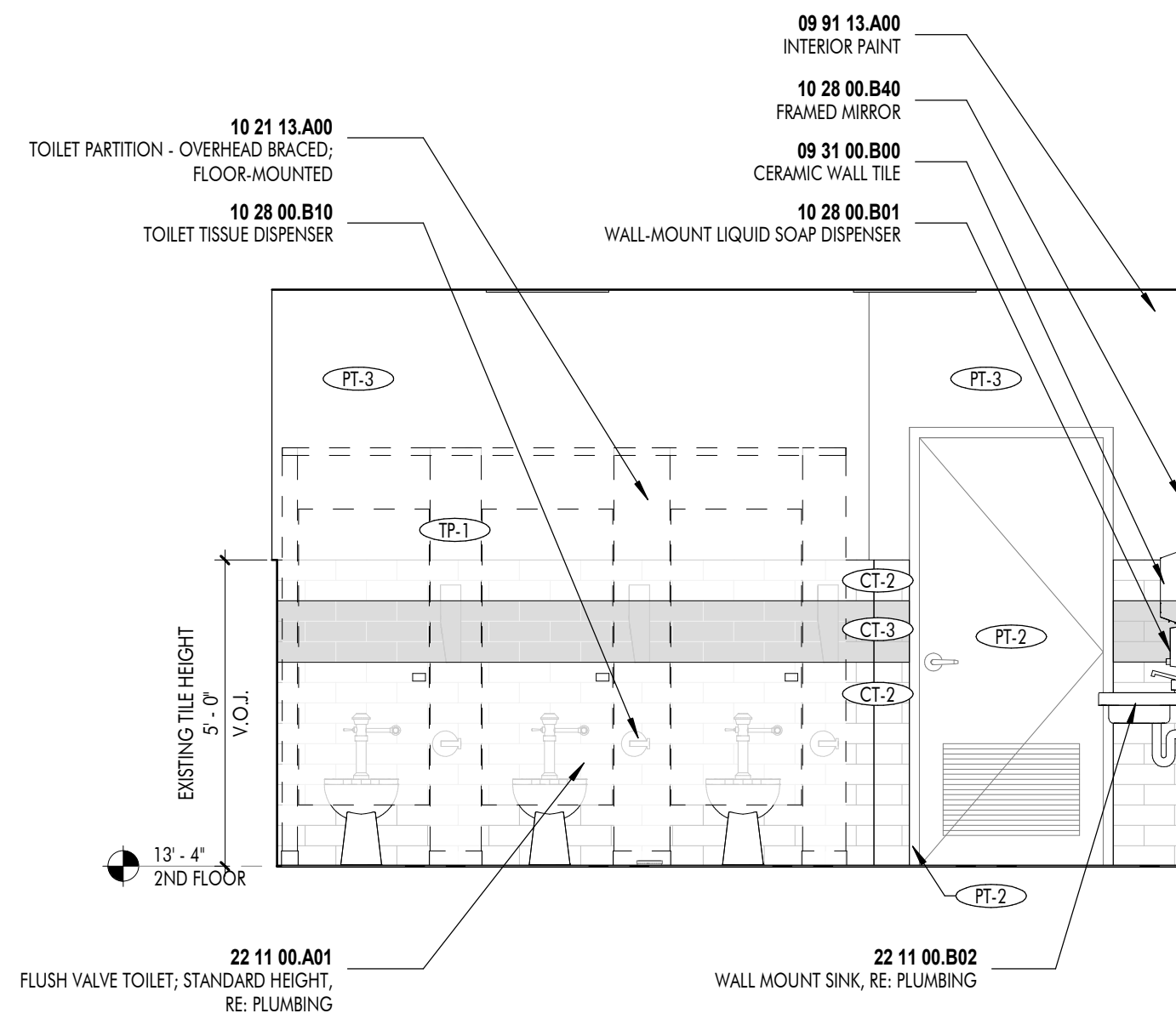
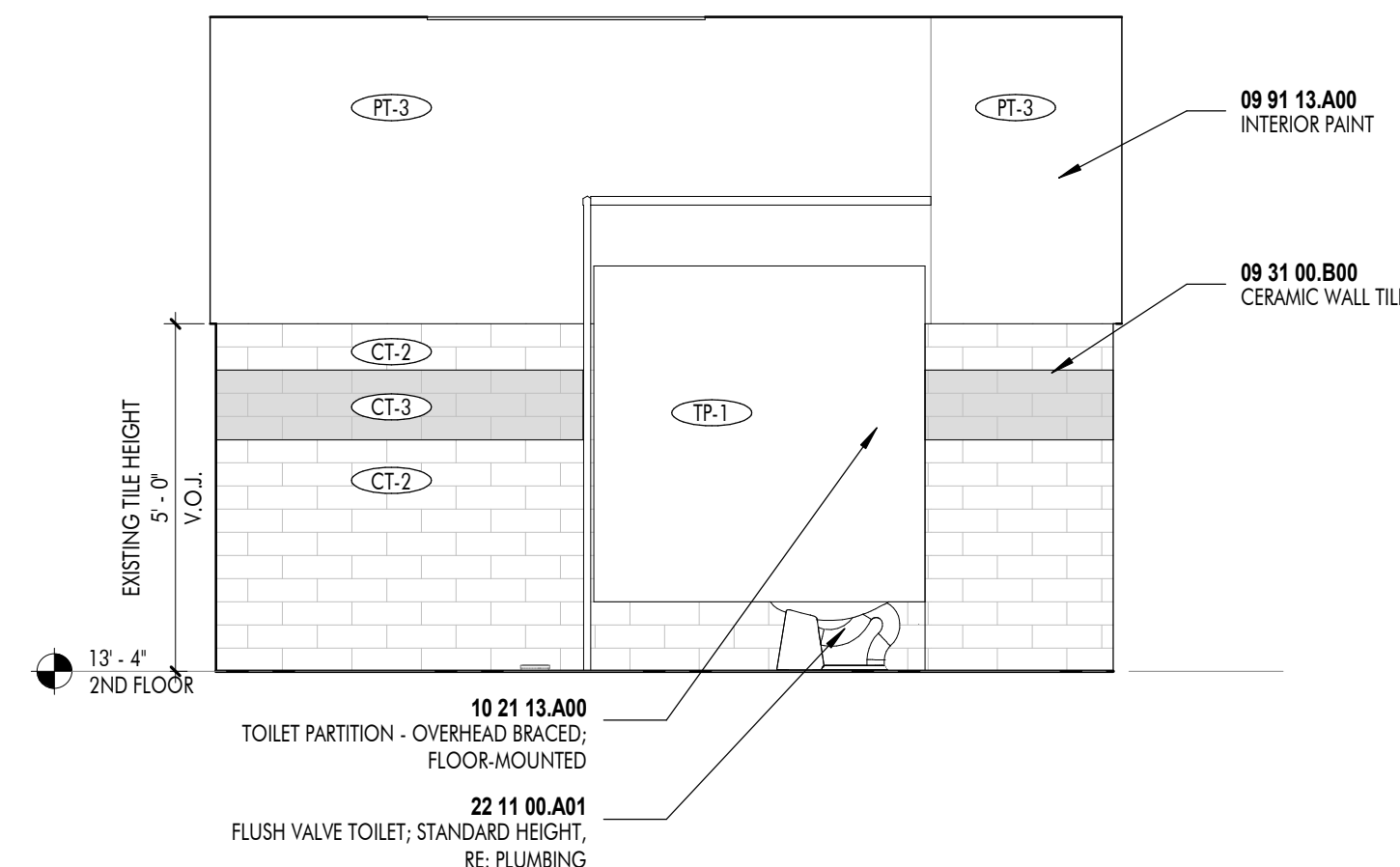
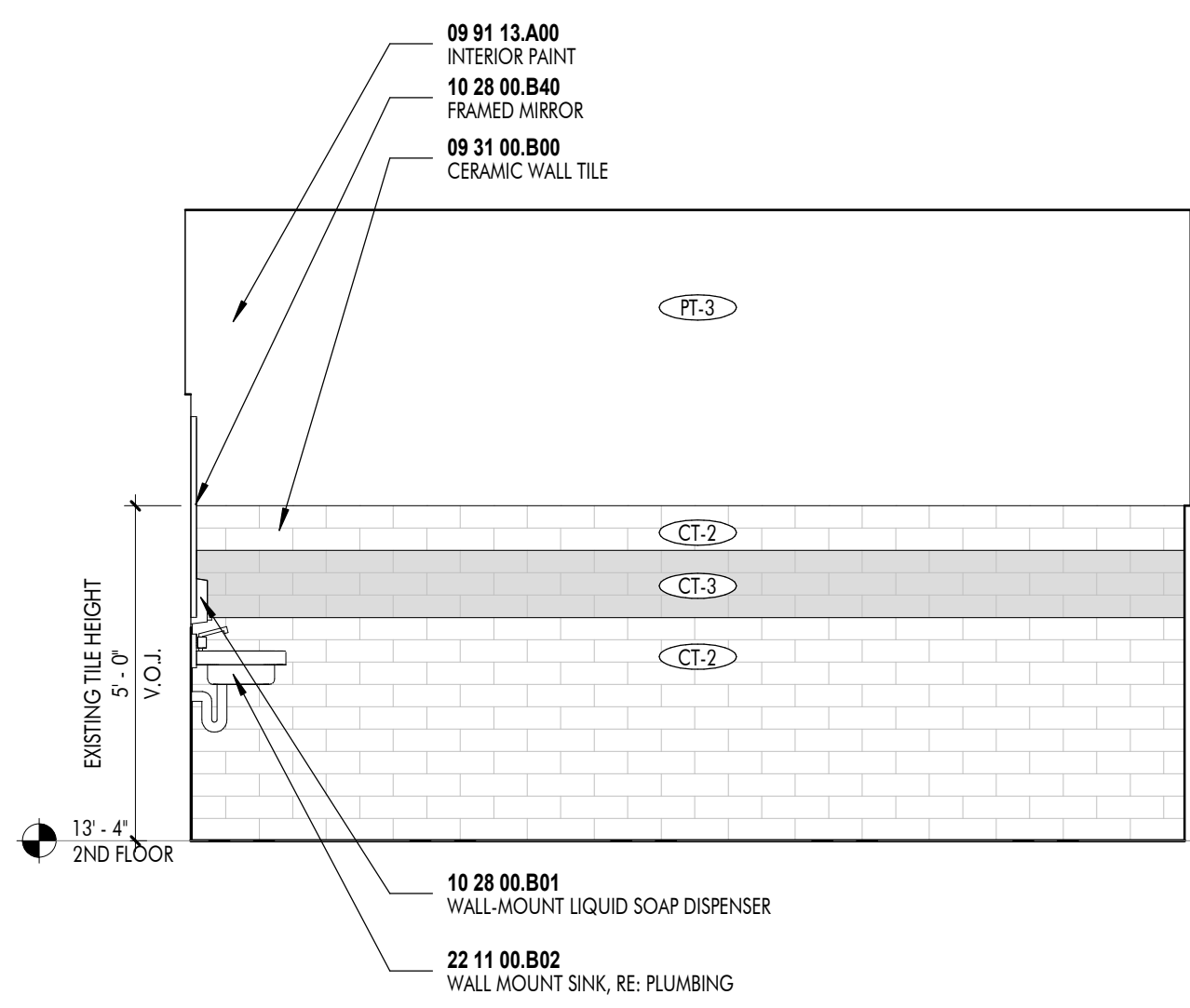

**5** 2ND FLOOR GIRLS - NORTH  
3/8" = 1'-0" DRAWN BY: KAS

**6** 2ND FLOOR GIRLS - EAST  
3/8" = 1'-0" DRAWN BY: KAS

**7** 2ND FLOOR GIRLS - SOUTH  
3/8" = 1'-0" DRAWN BY: KAS

**8** 2ND FLOOR GIRLS - WEST  
3/8" = 1'-0" DRAWN BY: KAS

ARCHITECT

**DOMAIN**  
ARCHITECTURE

8316 kelwood  
avenue  
baton rouge, la 70806  
t: 225.216.3770 f: 225.216.3771  
www.domain-arch.com

REGISTRATION

These drawings are the property of DOMAIN ARCHITECTURE APC and are not to be reproduced in whole or in part. They are only to be used for the project and site specifically identified herein. Scales stated hereon are valid on the original drawings only. Contractor shall carefully review all dimensions and conditions shown and report to the architect any errors, inconsistencies, or omissions discovered. These plans were prepared in the office under our personal supervision, and to the best of our knowledge comply with state and local codes. We will generally administer construction.

CLIENT

Southern University Laboratory School  
**RESTROOM RENOVATIONS**

129 SWAN AVE,  
BATON ROUGE, LA 70813

PROJECT INFORMATION	
revisions	Date
No.	Description
project #	C22-0072
date	AUGUST 31, 2023
director review	

2ND FLOOR GIRLS

**A9.15**

AUGUST 31, 2023





These drawings are the property of DOMAIN ARCHITECTURE APAC and are not to be reproduced in whole or in part. They are only to be used for the project and site specifically identified herein. Scales stated thereon are valid on the original drawing only. Contractor shall carefully review all dimensions and conditions shown and report to the architect any errors, inconsistencies, or omissions discovered. These plans were prepared in the office under our personal supervision, and to the best of our knowledge comply with state and local codes. We will generally administer construction.

CLIENT

Southern University Laboratory School  
**RESTROOM RENOVATIONS**  
 129 SWAN AVE,  
 BATON ROUGE, LA 70813

PROJECT INFORMATION	
revisions	Date
No.	Description

project # **C22-0072**  
 date **AUGUST 31, 2023**  
 director review

ADA 2 - RESTROOM

CONSTRUCTION NOTES	
MARK	DESCRIPTION
1	REMOVE EXISTING FLOOR TILE. PATCH AND PREP FLOOR TO RECEIVE NEW TILE AS SCHEDULED. PROVIDE LEVELING COMPOUND AS NECESSARY. MOISTURE TEST EXISTING FLOOR BEFORE NEW FLOOR IS INSTALLED. THOROUGHLY CLEAN EXISTING FLOOR DRAIN.
2	MARBLE THRESHOLD TO BE PROTECTED FOR DURATION OF CONSTRUCTION. THRESHOLD TO BE CLEANED AT END OF CONSTRUCTION.
3	REMOVE DOORSTOP. PATCH AND PREP FLOOR TO RECEIVE NEW DOORSTOP.
4	REMOVE PAINT AND RUST FROM EXISTING STOREFRONT. PREP SURFACE TO RECEIVE NEW PAINT.
5	CONTRACTOR TO ENSURE WALL IS A FINISH LEVEL OF 4. REMOVE ANY FLAKING PAINT. SAND WALL FOR SMOOTH SURFACE AND PREP FOR NEW PAINT.
6	CAREFULLY REMOVE ANY EXISTING INTERIOR SIGNAGE. PATCH AND PREP WALL FOR NEW PAINT.
7	REMOVE EXISTING PLUMBING FIXTURE. MAINTAIN EXISTING PLUMBING FOR REUSE.
8	THOROUGHLY CLEAN DOOR, FRAME AND HARDWARE. RE-CAULK DOOR FRAME. RE: ABATEMENT DRAWINGS.
9	REMOVE EXISTING PAINT ON DOOR AND DOOR FRAME. PREP DOOR AND DOOR FRAME TO RECEIVE NEW PAINT. RE: ABATEMENT DRAWINGS.
10	CAREFULLY REMOVE DOOR, FRAME AND HARDWARE. PREP OPENING FOR NEW DOOR. RE: ABATEMENT DRAWINGS.
11	REMOVE TOILET PARTITIONS. PATCH AND PREP WALL FOR NEW PAINT.
12	REMOVE ALL EXISTING RESTROOM ACCESSORIES. (INCLUDING BUT NOT LIMITED TO MIRROR, TOILET PAPER HOLDER, GRAB BARS, SOAP DISPENSER, PAPER TOWEL DISPENSER, TOILET CLEANER)
13	CAREFULLY REMOVE EXISTING TILE ON WALLS. PATCH AND PREP WALL TO RECEIVE NEW TILE.
14	MAINTAIN AND PROTECT FIRE ALARM AND ALL RELATED CONDUIT.
15	CONTRACTOR TO ENSURE CEILING IS A FINISH LEVEL OF 4. REMOVE ANY FLAKING PAINT. SAND CEILING FOR SMOOTH SURFACE AND PREP FOR NEW PAINT.
16	REMOVE EXISTING RADIATOR AND ALL ACCESSORIES ASSOCIATED WITH IT. PATCH AND PREP WALL.
17	PATCH HOLE IN THE WALL. PREP SURFACE TO RECEIVE NEW TILE.
18	REMOVE EXISTING LOCKERS.
19	REMOVE CONCRETE CURB. PROTECT SURROUNDING CONCRETE.
20	REMOVE EXISTING BENCH. PATCH AND PREP CONCRETE TO RECEIVE NEW SEAL.
21	REMOVE EXISTING CEILING. PATCH AND PREP WALL TO RECEIVE NEW CEILING.
22	CAREFULLY REMOVE AND SALVAGE SUPPLY VENT FOR REUSE. REMOVE ANY PAINT FROM SURFACE AND CLEAN THOROUGHLY.
23	CAREFULLY REMOVE AND SALVAGE RETURN VENT FOR REUSE. REMOVE ANY PAINT FROM SURFACE AND CLEAN THOROUGHLY.
24	CAREFULLY REMOVE AND SALVAGE EXHAUST FAN FOR REUSE. REMOVE ANY PAINT FROM SURFACE AND CLEAN THOROUGHLY.
25	CAREFULLY REMOVE SURFACE MOUNTED LIGHT FIXTURE. ELECTRICAL TO REMAIN FOR REUSE.
26	REMOVE ALL LIGHT FIXTURES FROM ENTIRE ROOM. ELECTRICAL TO REMAIN FOR REUSE. CAP ANY ELECTRICAL NOT REUSED.
27	CAREFULLY REMOVE HANGING LIGHT FIXTURE. ELECTRICAL TO REMAIN FOR REUSE.
28	PREP PLASTER CEILING TO RECEIVE NEW PAINT.
29	PREP METAL CEILING TO RECEIVE NEW PAINT.
30	REMOVE DOOR, FRAME AND HARDWARE. PREPARE OPENING TO BE INFILLED.
31	REMOVE PORTION OF EXISTING WALL TO RECEIVE NEW DOOR.
A	MAIN STAGING AREA FOR CONTRACTOR
B	SUB-STAGING / PARKING AREA
C	STAGING AREAS SHALL BE REGRADED AND SEEDED WHEN THE CONSTRUCTION PROJECT HAS BEEN COMPLETED.
D	STAGING AREAS MUST BE FENCED AND LOCKABLE ALL TIMES.

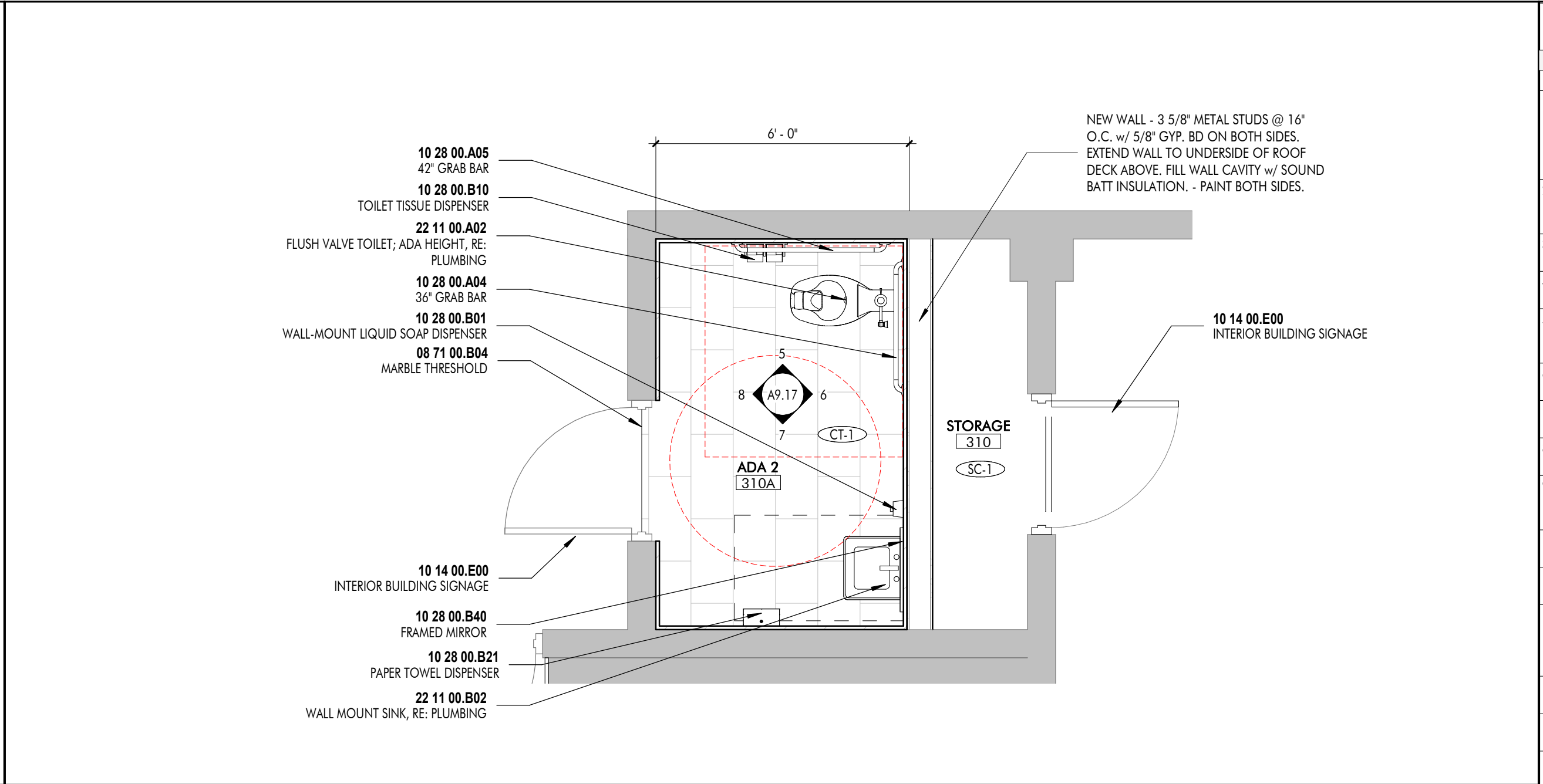
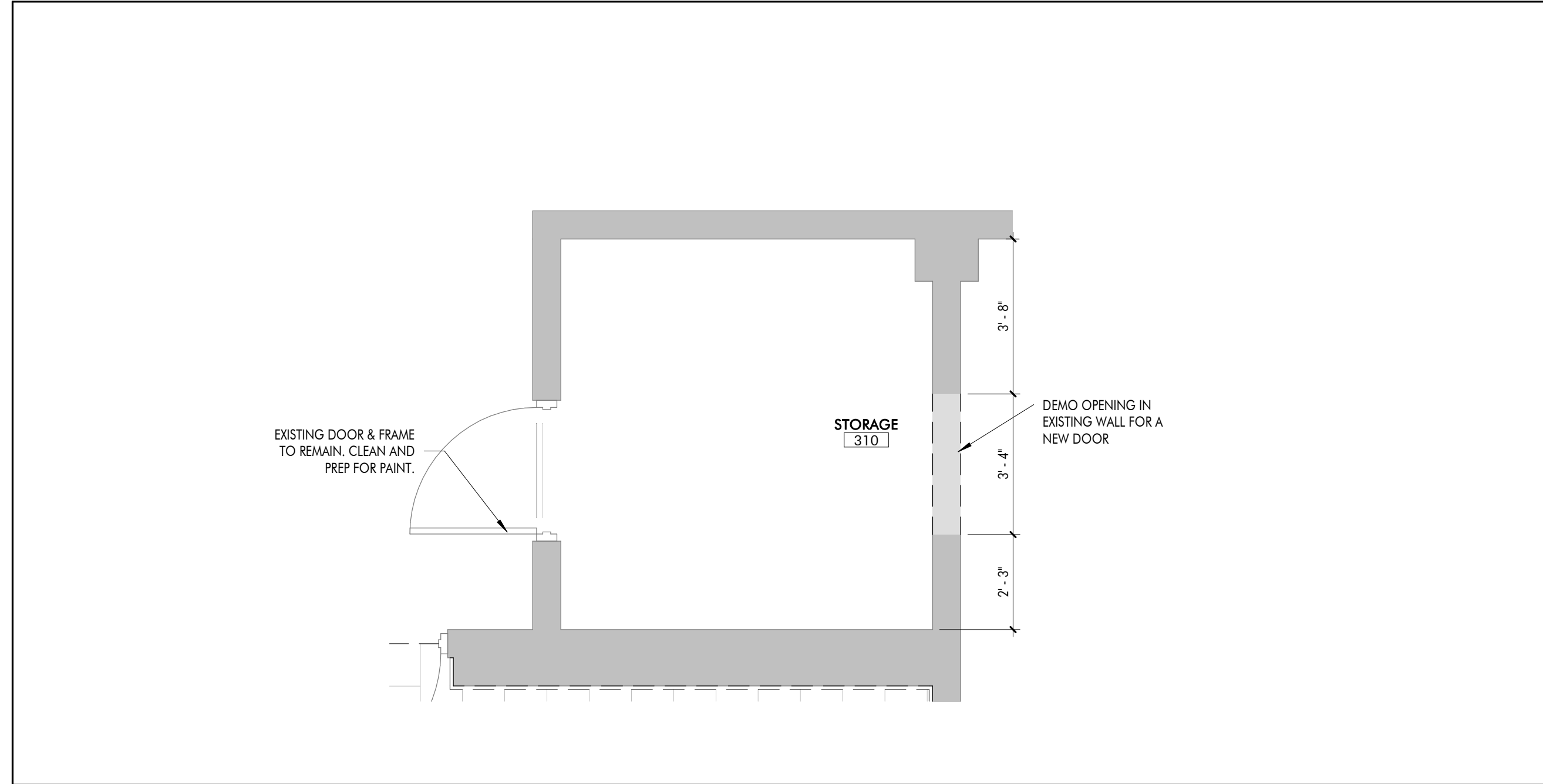

**1** ADA 2 - DEMOLITION  
 3/8" = 1'-0" DRAWN BY: KAS

**2** ADA 2 - NEW CONSTRUCTION  
 3/8" = 1'-0" DRAWN BY: KAS

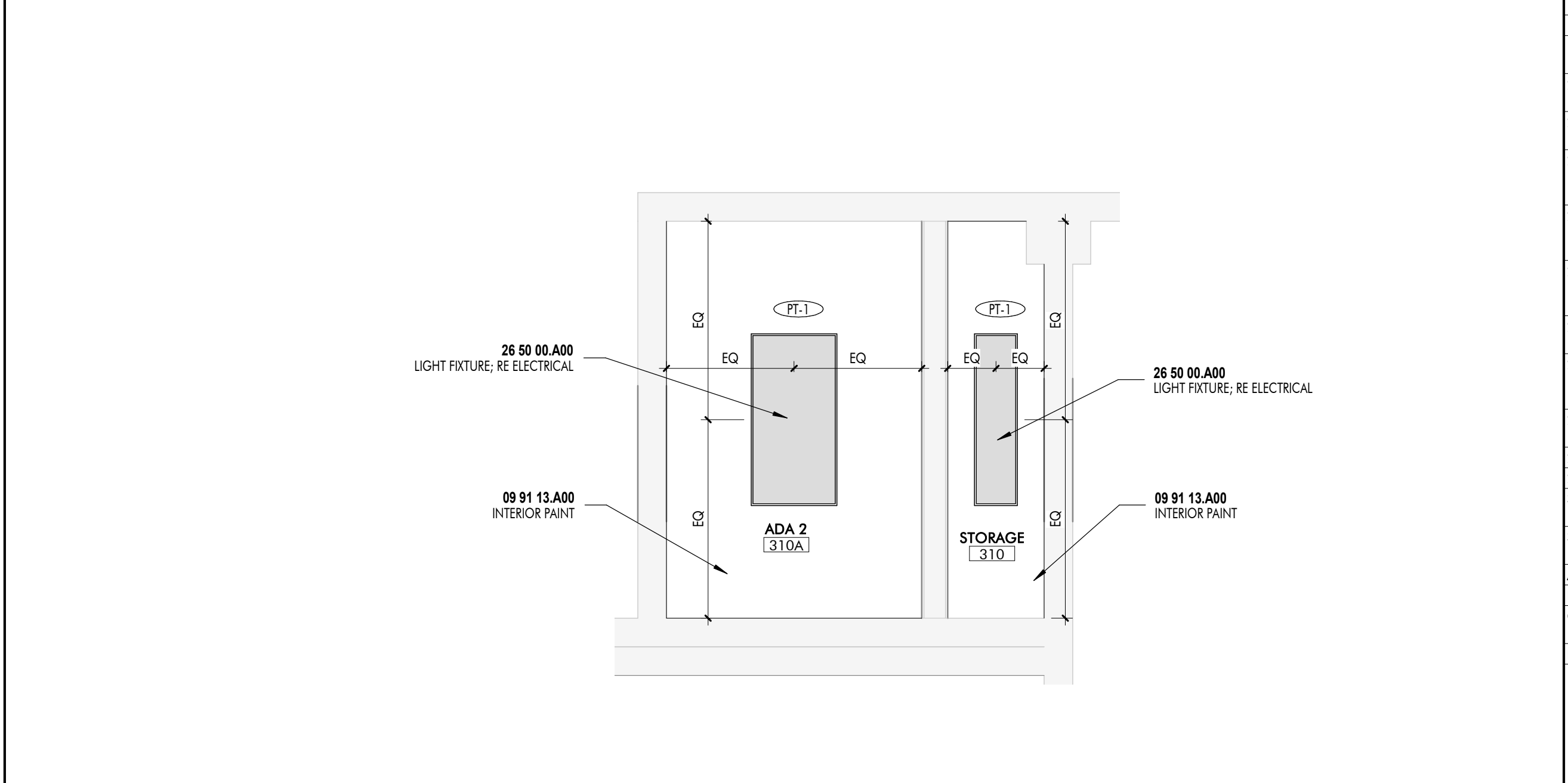
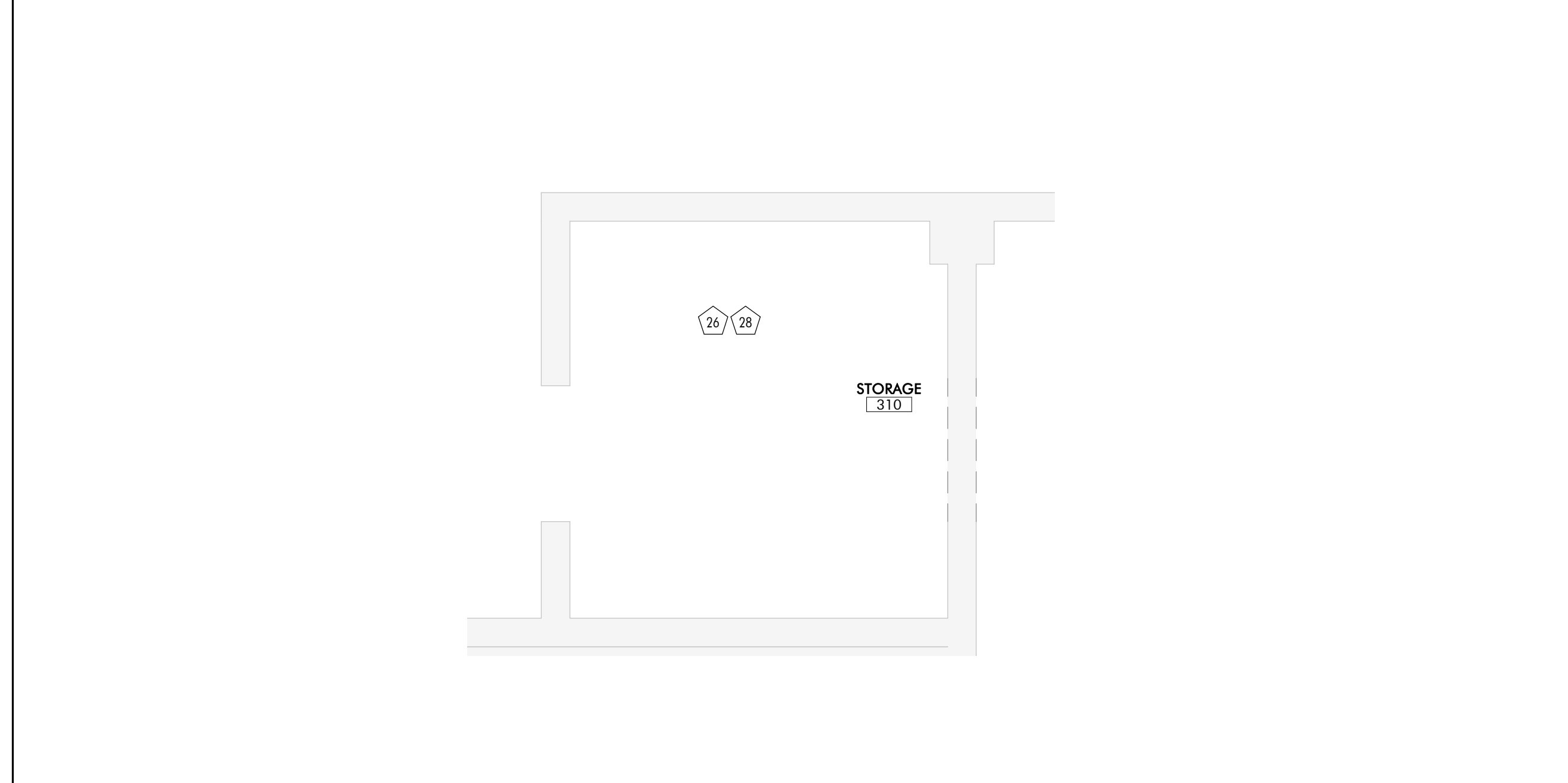

**3** ADA 2 - DEMO RCP  
 3/8" = 1'-0" DRAWN BY: KAS

**4** ADA 2 - NEW CONSTRUCTION RCP  
 3/8" = 1'-0" DRAWN BY: KAS

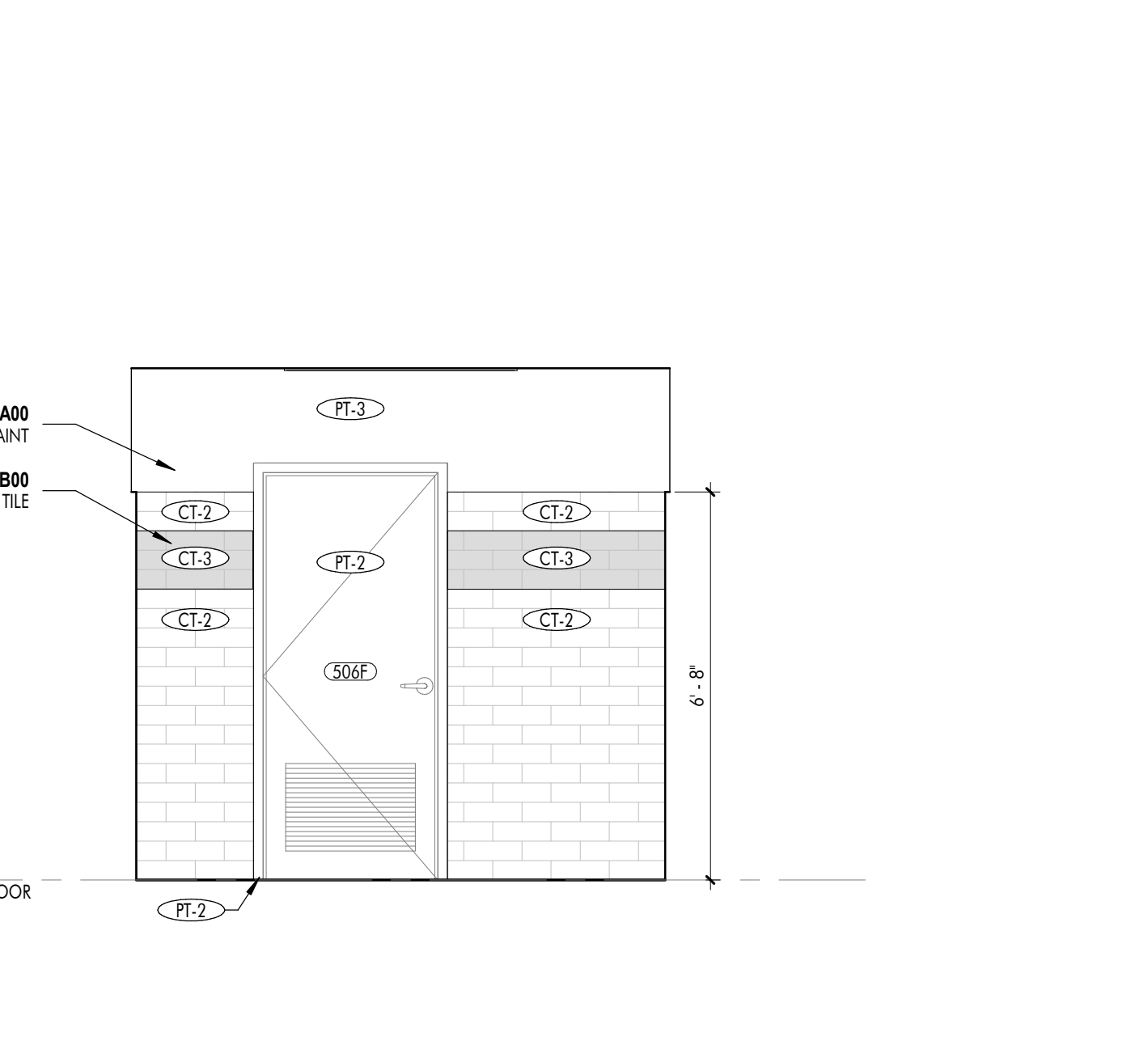
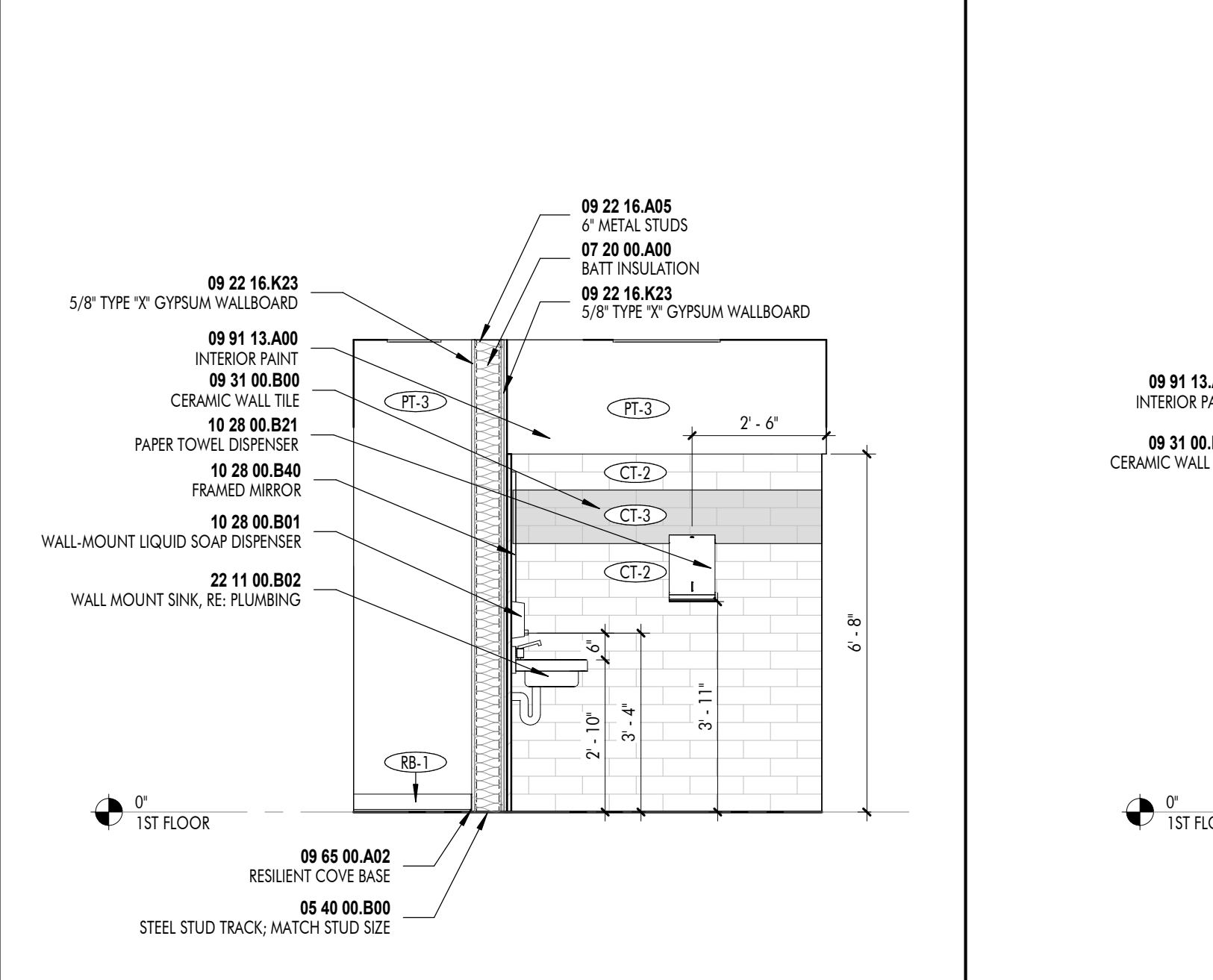
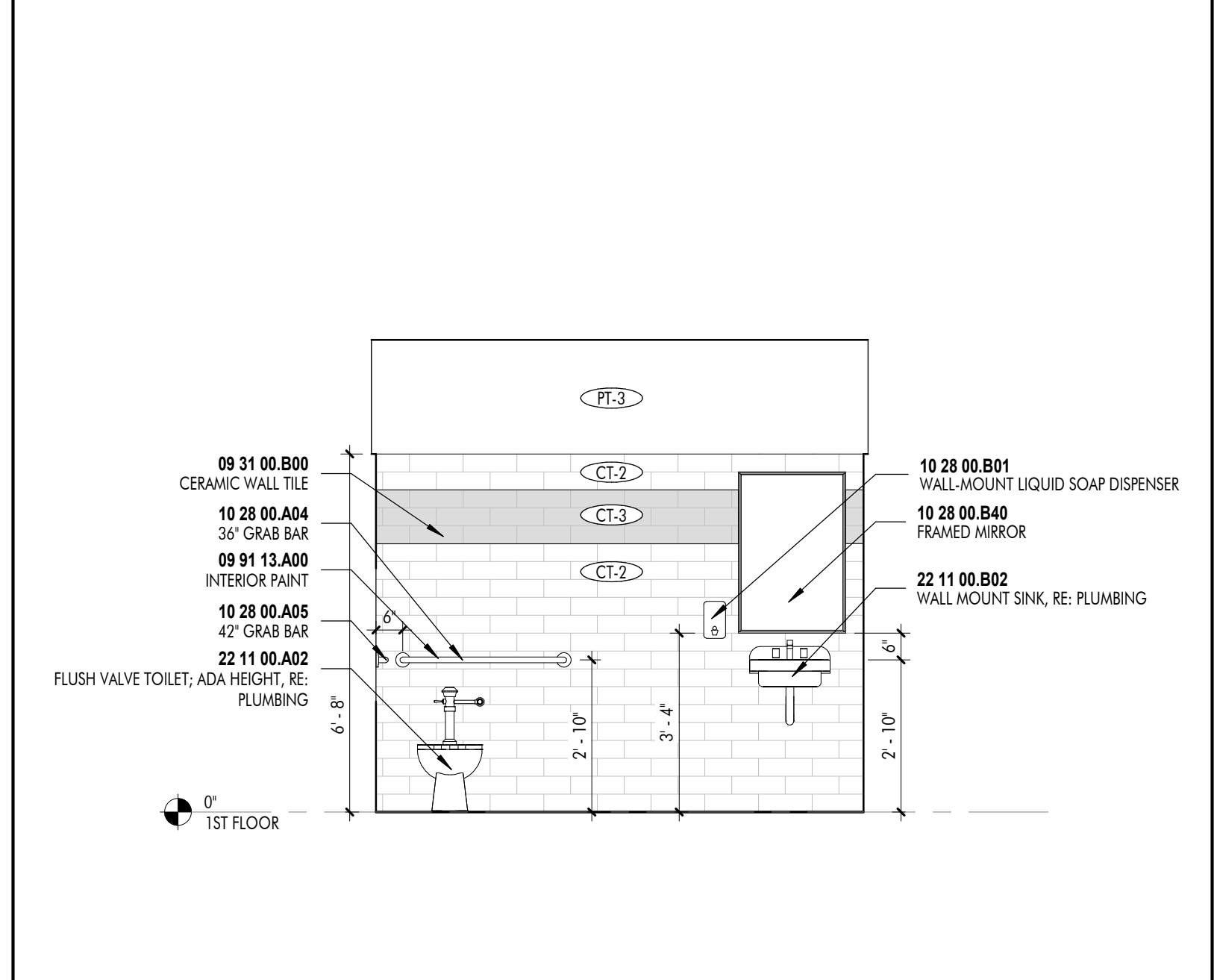
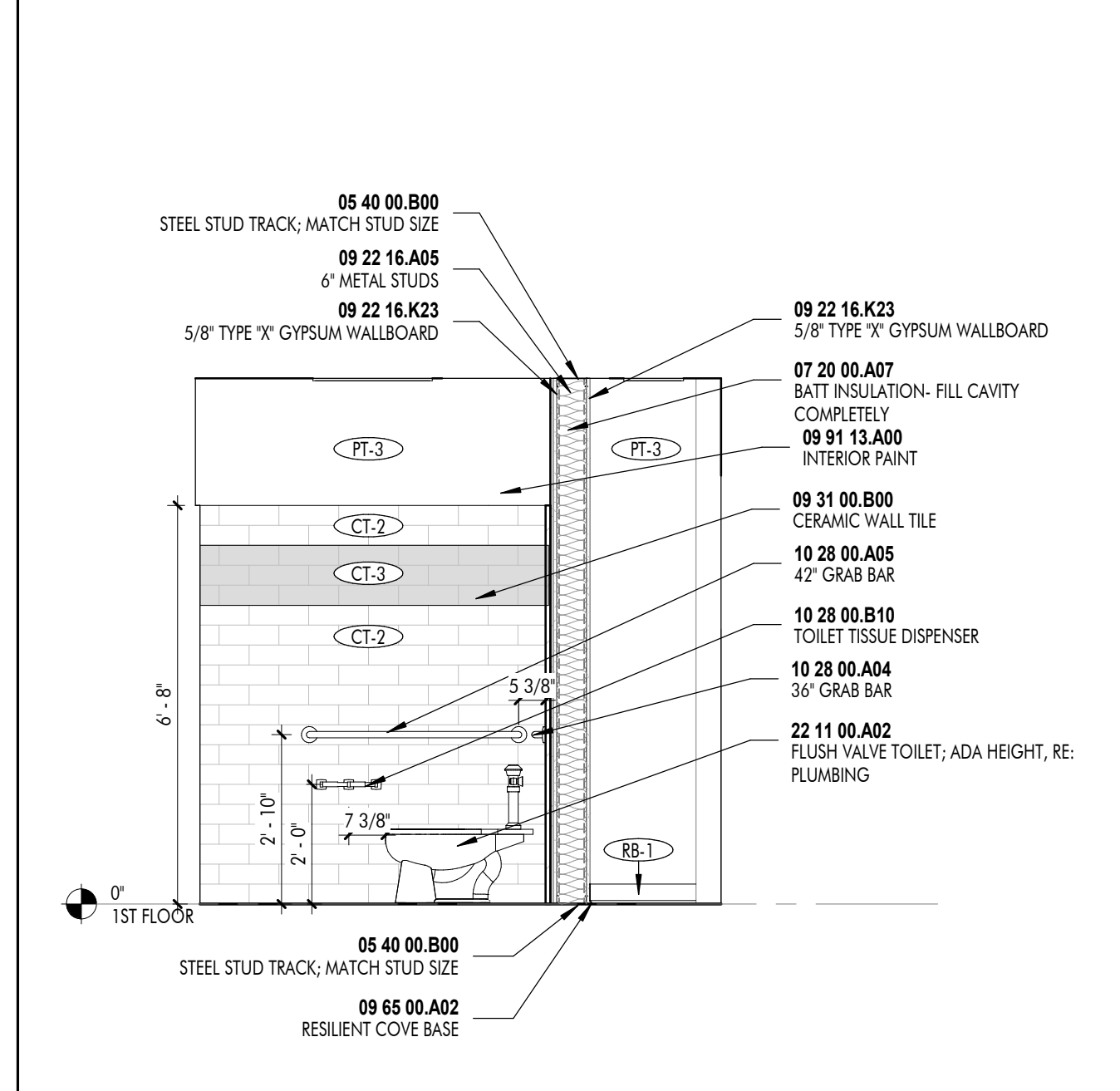

**5** ADA 2 - NORTH  
 3/8" = 1'-0" DRAWN BY: KAS

**6** ADA 2 - EAST  
 3/8" = 1'-0" DRAWN BY: KAS

**7** ADA 2 - SOUTH  
 3/8" = 1'-0" DRAWN BY: KAS

**8** ADA 2 - WEST  
 3/8" = 1'-0" DRAWN BY: KAS

### 1 GENERAL NOTES

- 1 PROVIDE ALL MATERIALS AND EQUIPMENT AND PERFORM ALL LABOR REQUIRED TO INSTALL COMPLETE AND OPERABLE MECHANICAL SYSTEMS AS INDICATED ON THE DRAWINGS, AS SPECIFIED AND AS REQUIRED BY CODE
- 2 CONTRACT DOCUMENT DRAWINGS FOR MECHANICAL WORK (HVAC, PLUMBING AND FIRE PROTECTION) ARE DIAGRAMMATIC AND ARE INTENDED TO CONVEY SCOPE AND GENERAL ARRANGEMENT ONLY
- 3 INSTALL ALL MECHANICAL EQUIPMENT AND APPURTENANCES IN ACCORDANCE WITH MANUFACTURERS' RECOMMENDATIONS, CONTRACT DOCUMENTS, AND APPLICABLE CODES AND REGULATIONS
- 4 PROVIDE VIBRATION ISOLATION FOR ALL MECHANICAL EQUIPMENT TO PREVENT TRANSMISSION OF VIBRATION TO BUILDING STRUCTURE
- 5 THE LOCATION OF EXISTING UNDERGROUND UTILITIES IS SHOWN IN AN APPROXIMATE WAY ONLY. THE CONTRACTOR SHALL DETERMINE THE EXACT LOCATION OF ALL EXISTING UTILITIES BEFORE COMMENCING WORK. THE CONTRACTOR SHALL PAY FOR AND REPAIR ALL DAMAGES CAUSED BY FAILURE TO EXACTLY LOCATE AND PRESERVE ANY AND ALL UNDERGROUND UTILITIES UNLESS OTHERWISE INDICATED
- 6 COORDINATE CONSTRUCTION OF ALL MECHANICAL WORK WITH ARCHITECTURAL, STRUCTURAL, CIVIL, ELECTRICAL WORK, ETC., SHOWN ON OTHER CONTRACT DOCUMENT DRAWINGS
- 7 MAINTAIN A MINIMUM OF 6'-8" CLEARANCE TO UNDERSIDE OF PIPES, DUCTS, CONDUITS, SUSPENDED EQUIPMENT, ETC., THROUGHOUT ACCESS ROUTES IN MECHANICAL ROOMS
- 8 ALL TESTS SHALL BE COMPLETED BEFORE ANY MECHANICAL EQUIPMENT OR PIPING INSULATION IS APPLIED
- 9 LOCATE ALL TEMPERATURE PRESSURE AND FLOW MEASURING DEVICES IN ACCESSIBLE LOCATIONS WITH STRAIGHT SECTION OF PIPE OR DUCT UP- AND DOWN STREAM AS RECOMMENDED BY THE MANUFACTURER FOR GOOD ACCURACY
- 10 WHERE TWO OR MORE ITEMS OF THE SAME TYPE OF EQUIPMENT ARE REQUIRED, THE PRODUCT OF ONE MANUFACTURER SHALL BE USED
- 11 REINFORCEMENT, DETAILING, AND PLACEMENT OF CONCRETE SHALL CONFORM TO ASTM 315 AND ACI 318. CONCRETE SHALL CONFORM TO ASTM C94. CONCRETE WORK SHALL CONFORM TO ACI 318, PART ENTITLED "CONSTRUCTION REQUIREMENTS". COMPRESSIVE STRENGTH IN 28 DAYS SHALL BE 3000 PSI. TOTAL AIR CONTENT OF EXTERIOR CONCRETE SHALL BE BETWEEN 5 AND 7 PERCENT BY VOLUME. SLUMP SHALL BE BETWEEN 3 AND 4 INCHES. CONCRETE SHALL BE CURED FOR 7 DAYS AFTER PLACEMENT.
- 12 COORDINATE ALL EQUIPMENT CONNECTION WITH MANUFACTURERS' CERTIFIED DRAWINGS. COORDINATE AND PROVIDE ALL DUCT AND PIPING TRANSITIONS REQUIRED FOR FINAL EQUIPMENT CONNECTIONS TO FURNISHED EQUIPMENT. FIELD VERIFY AND COORDINATE ALL DUCT AND PIPING DIMENSIONS BEFORE FABRICATION.
- 13 ALL CONTROL WIRE AND CONDUIT SHALL COMPLY WITH THE NATIONAL ELECTRIC CODE AND DIVISION 16 OF THE SPECIFICATION
- 14 MINIMUM CONCRETE PAD THICKNESS SHALL BE 4 INCHES. PAD SHALL EXTEND BEYOND THE EQUIPMENT A MINIMUM OF 6 INCHES ON EACH SIDE UNLESS OTHERWISE DIRECTED IN THESE DOCUMENTS
- 15 LOCATIONS AND SIZES OF ALL FLOOR, WALL, AND ROOF OPENINGS SHALL BE COORDINATED WITH ALL OTHER TRADES INVOLVED
- 16 REFER TO TYPICAL DETAILS FOR DUCTWORK, PIPING, AND EQUIPMENT INSTALLATION

### 2 PLUMBING NOTES

- 1 PROVIDE ALL MATERIALS AND EQUIPMENT AND PERFORM ALL LABOR REQUIRED TO INSTALL COMPLETE AND OPERABLE PLUMBING SYSTEMS AS INDICATED ON THE DRAWINGS, AS SPECIFIED AND AS REQUIRED BY CODE
- 2 PROVIDE SHUTOFF VALVES IN ALL DOMESTIC WATER PIPING SYSTEMS BRANCHES IN WHICH BRANCH PIPING SERVES TWO OR MORE FIXTURES
- 3 UNLESS OTHERWISE DIRECTED IN THESE DOCUMENTS, ALL DOMESTIC COLD AND HOT WATER PIPING SHALL BE SAME SIZE AS NOTED ON THE PLUMBING FIXTURE SCHEDULE
- 4 UNLESS OTHERWISE DIRECTED IN THESE DOCUMENTS, ALL PIPING IS OVERHEAD, TIGHT TO UNDERSIDE OF SLAB, WITH SPACE FOR INSULATION IF REQUIRED
- 5 INSTALL PIPING SO THAT ALL VALVES, STRAINERS, UNIONS, TRAPS, FLANGES, AND OTHER APPURTENANCES REQUIRING ACCESS ARE ACCESSIBLE
- 6 WHERE DOMESTIC COLD AND HOT WATER PIPING DROPS INTO A PIPE CHASE, THE SIZE SHOWN FOR THE PIPE DROPS SHALL BE USED TO THE LAST FIXTURE UNLESS OTHERWISE DIRECTED IN THESE DOCUMENTS
- 7 INSTALL ALL PIPING WITHOUT FORCING OR SPRINGING
- 8 ALL PIPING SHALL CLEAR DOORS AND WINDOWS
- 9 ALL PIPING SHALL GRADE TO LOW POINTS. PROVIDE HOSE END DRAIN VALVES AT THE BOTTOM OF ALL RISERS AND LOW POINTS
- 10 UNIONS AND/OR FLANGES SHALL BE INSTALLED AT EACH PIECE OF EQUIPMENT, IN BYPASSES, AND IN LONG PIPING RUNS (100 FEET OR MORE) TO PERMIT DISASSEMBLY FOR ALTERATION AND REPAIRS
- 11 ALL VALVES SHALL BE ADJUSTED FOR SMOOTH AND EASY OPERATION
- 12 ALL VALVES (EXCEPT CONTROL VALVES) AND STRAINERS SHALL BE FULL SIZE OF PIPE BEFORE REDUCING SIZE TO MAKE CONNECTION TO EQUIPMENT AND CONTROLS
- 13 PROVIDE ALL PLUMBING FIXTURES AND EQUIPMENT WITH ACCESSIBLE STOPS
- 14 UNLESS OTHERWISE DIRECTED IN THESE DOCUMENTS, DRAINS SHALL BE INSTALLED AT THE LOW POINT OF ROOFS, AREAWAYS, FLOORS, ETC.
- 15 PROVIDE CLEANOUTS IN SANITARY AND STORM DRAINAGE SYSTEMS AT ENDS OF RUNS, AT CHANGES IN DIRECTION, NEAR THE BASE OF STACKS, EVERY 50 FEET IN HORIZONTAL RUNS AND ELSEWHERE AS INDICATED (EDIT HORIZONTAL CLEANOUT SPACING TO SUIT CODE AND PROJECT REQUIREMENTS)
- 16 ALL CLEANOUTS SHALL BE FULL SIZE OF PIPE FOR BUILDING DRAINS 6 INCHES AND SMALLER AND SHALL BE 6 INCHES FOR BUILDING DRAINS LARGER THAN 6 INCHES
- 17 ALL BALANCING VALVES AND BUTTERFLY VALVES SHALL BE PROVIDED WITH POSITION INDICATORS AND MAXIMUM ADJUSTABLE STOPS (MEMORY STOPS)
- 18 ALL VALVES SHALL BE INSTALLED SO THAT VALVE REMAINS IN SERVICE WHEN EQUIPMENT OR PIPING ON EQUIPMENT SIDE OF VALVE IS REMOVED
- 19 ALL PIPING WORK SHALL BE COORDINATED WITH ALL TRADES INVOLVED. OFFSETS IN PIPING AROUND OBSTRUCTIONS SHALL BE PROVIDED AT NO ADDITIONAL COST TO THE OWNER
- 20 PROVIDE FLEXIBLE CONNECTIONS IN ALL PIPING SYSTEMS CONNECTED TO PUMPS AND OTHER EQUIPMENT WHICH REQUIRE VIBRATION ISOLATION. FLEXIBLE CONNECTIONS SHALL BE PROVIDED AS CLOSE TO THE EQUIPMENT AS POSSIBLE OR AS INDICATED ON THE DRAWINGS

### 9 ABBREVIATIONS

AAV	AUTOMATIC AIR VENT	BTU	BRITISH THERMAL UNIT	CONC	CONCRETE	DN	DOWN	EWC	ELECTRIC WATER COOLER	FPI	FINS PER INCH	LPC	LOW PRESSURE CONDENSATE	MIN	MINIMUM	RIA	RETURN AIR	VD	VOLUME DAMPER
ABV	ABOVE	BTUH	BRITISH THERMAL UNIT/HOUR	CONT	CONTINUATION	DP	PRESSURE DROP	EWT	ENTERING WATER TEMPERATURE	FPM	FEET PER MINUTE	LPS	LOW PRESSURE STEAM	MOC	MAXIMUM OVERCURRENT PROTECTION	REF	REFRIGERANT	VRV	VARIABLE REFRIGERANT VOLUME
ACC	AIR COOLED CHILLER	CAP	CAPACITY	COP	COEFFICIENT OF PERFORMANCE	DWG	DRAWING	EXH	EXHAUST	FSD	COMBINATION FIRE SMOKE DAMPER	LWB	LEAVING WET BULB TEMPERATURE	MJA	MAKE-UP AIR UNIT	RLA	RATED LOAD AMPS	VTR	VENT THROUGH ROOF
AFF	ABOVE FINISHED ROOF	CAV	CONSTANT AIR VOLUME	CPH	COMPUTER ROOM AIR HANDLER	DX	DIRECT EXPANSION	FA	FREE AREA (SQUARE FEET)	FT	FEET	LWT	LEAVING WATER TEMPERATURE	NC	NORMALLY CLOSED	RPM	REVOLUTIONS PER MINUTE	W	WATTS
AFR	ABOVE FINISHED ROOF	CC	COOLING COIL	CV	CONSTANT VOLUME	EA	EACH	FC	FLEXIBLE CONNECTION	GPM	GALLONS PER MINUTE	MAV	MANUAL AIR VENT	NIC	NOT IN CONTRACT	RTU	ROOFTOP UNIT	WB	WET BULB
AHU	AIR HANDLING UNIT	CD	CONDENSATE DRAIN	CWR	CHILLED WATER RETURN	E/A	EXHAUST AIR	FCU	FAN COIL UNIT	HC	HEATING COIL	MAX	MAXIMUM	NO	NORMALLY OPEN	S/A	SUPPLY AIR	WCC	WATER COOLED CHILLER
A	AMPS	COWS	CONDENSER WATER SUPPLY	CWS	CHILLED WATER SUPPLY	EAT	ENTERING AIR TEMPERATURE	FD	FIRE DAMPER	HHWR	HOT WATER RETURN	MBH	1000 BTUH	NPSH	NET POSITIVE SUCTION HEAD	SEN	SENSIBLE		
ARCH	ARCHITECTURAL	COWR	CONDENSER WATER RETURN	dB	DECIBEL	EF	EXHAUST FAN	FLA	FULL LOAD AMPS	HHWS	HOT WATER SUPPLY	MCA	MINIMUM CIRCUIT AMPACITY	O/A	OUTSIDE AIR	TOT	TOTAL		
BDD	BACKDRAFT DAMPER	CFM	CUBIC FEET PER MINUTE	DB	DRY BULB	ELEC	ELECTRICAL	FLT	FILTER	KW	KILOWATT	MFG	MANUFACTURER	OPD	OPPOSED BLADE DAMPER	V	VOLTS		
BHP	BRAKE HORSEPOWER	CLG	CEILING	DG	DOOR GRILLE	ESP	EXTERNAL STATIC PRESSURE	FPB	FAN POWER BOX	LAT	LEAVING AIR TEMPERATURE	MHP	MOTOR HORSEPOWER	QTY	QUANTITY	VAV	VARIABLE AIR VOLUME		

ALL SYMBOLS, ABBREVIATIONS, AND NOTES ABOVE ARE TYPICAL AND ARE NOT NECESSARILY USED IN THESE CONSTRUCTION DOCUMENTS

### 3 SYMBOL LEGEND

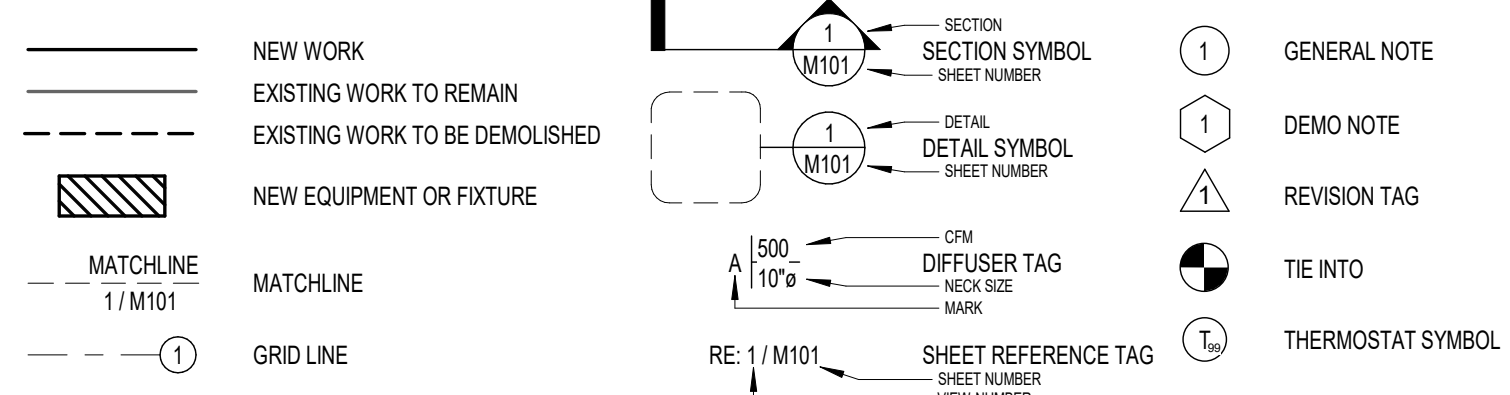

### 4 DUCTWORK LEGEND

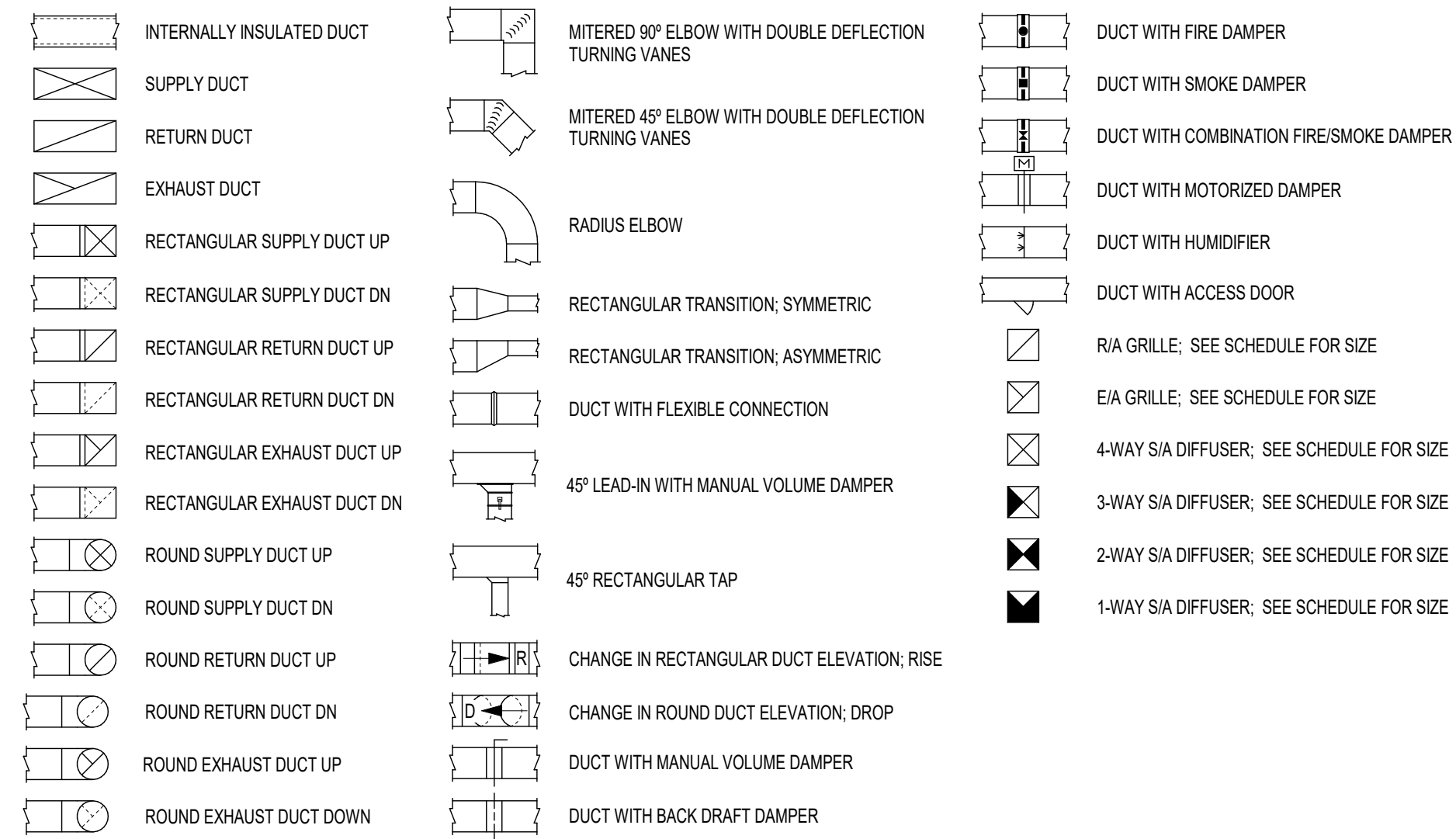

### 5 PIPING LEGEND

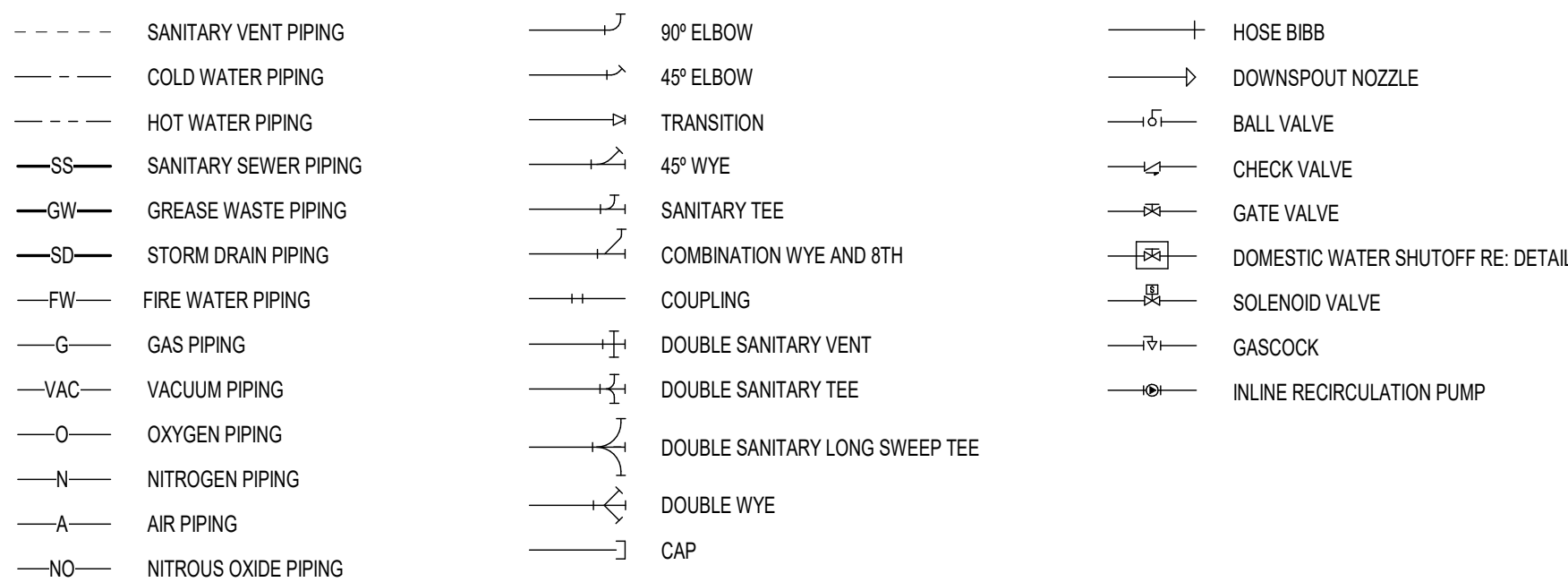

### 6 FIRE PROTECTION LEGEND



### 7 MECHANICAL NOTES

- 1 DUCTWORK DIMENSIONS GIVEN ARE METAL TO METAL
- 2 REFER TO DIFFUSER AND GRILLE SCHEDULE FOR BRANCH DUCT SIZE UNLESS OTHERWISE DIRECTED IN THESE DOCUMENTS
- 3 REFER TO MECHANICAL SCHEDULE SHEET FOR EQUIPMENT, DIFFUSER, AND GRILLE SCHEDULES
- 4 INSTALL TRANSITION DUCT FROM INLET AND OUTLET OF EQUIPMENT TO DUCT SIZE SHOWN ON PLANS; CONSULT EQUIPMENT MANUFACTURER FOR INLET AND OUTLET SIZE
- 5 ALL DUCT ELBOWS, BENDS, AND TEES SHALL BE PROVIDED WITH DOUBLE THICKNESS TURNING VANES OR RADIUS ELBOWS UNLESS SHOWN OR NOTED OTHERWISE. ELBOWS IN DISHWASHER, KITCHEN, AND LAUNDRY EXHAUST SHALL BE UNWAVED SMOOTH RADIUS CONSTRUCTION WITH A RADIUS OF 1.5 TIMES THE WIDTH OF THE DUCT
- 6 REFER TO ELECTRICAL AND PLUMBING DRAWINGS FOR COORDINATION WITH MECHANICAL DRAWINGS. OFFSETS IN DUCTS, INCLUDING DIVIDED DUCTS AND TRANSITIONS AROUND OBSTRUCTIONS, SHALL BE PROVIDED AT NO ADDITIONAL COST TO THE OWNER
- 7 EQUIPMENT SIZES AND SERVICE SPACE REQUIREMENTS VARY AMONG MANUFACTURERS; CONSULT MANUFACTURER DATA FOR SPACE REQUIREMENTS AND VERIFY SPACE ADEQUACY
- 8 DO NOT BLOCK TUBE PULL, FILTER PULL, COIL PULL, SAFETY OR SERVICE CLEARANCE SPACE ON EQUIPMENT WITH PIPING, DUCTWORK, ETC. FLANGED OR REMOVABLE SECTIONS MAY BE USED IN SOME INSTANCES WHERE TIGHT CLEARANCES EXIST; VERIFY WITH ARCHITECT IN SUCH CASE
- 9 REFER TO ARCHITECTURAL REFLECTIVE CEILING PLAN DRAWINGS FOR COORDINATION OF MECHANICAL ITEMS TO BE INSTALLED IN CEILING AND MAKE MINOR DUCT MODIFICATIONS TO SUIT
- 10 PROVIDE ESCUTCHEONS AT ALL EXPOSED LOCATIONS WHERE PIPE PENETRATES WALL
- 11 ROOM NUMBERS AND NAMES ON THE CONSTRUCTION DOCUMENTS ARE FOR CONSTRUCTION PURPOSES ONLY AND CAN CHANGE DURING CONSTRUCTION; OBTAIN FINAL ROOM NUMBERS AND NAMES FROM THE ARCHITECT
- 12 WHERE CONCEALED BY INACCESSIBLE FINISHES, PROVIDE ACCESS DOORS TO ALL VALVE BOXES, VALVES, DUCT STATIC PRESSURE SENSORS, MANUAL VOLUME DAMPERS, FIRE DAMPERS, FIRE/SMOKE CONTROLS, AIR VENTS, DRAIN CONNECTIONS AND ALL OTHER ITEMS REQUIRING PERIODIC MAINTENANCE, OPERATION, OR ADJUSTMENT. ACCESS DOORS ARE TO BE SIZED AND LOCATED FOR EASY PERFORMANCE OF THE FUNCTION INTENDED. COORDINATE LOCATION OF ACCESS DOORS WITH ALL TRADES AFFECTED
- 13 ALL EQUIPMENT INSTALLATIONS SHALL BE INSTALLED TO MEET THE INSTALLATION AND OPERATION REQUIREMENT OF THE EQUIPMENT MANUFACTURER AND ALL CODES AND REGULATIONS IN EFFECT IN THE AREA WHERE WORK IS DONE
- 14 THE CONDENSATE DRAIN LINE SHALL NOT DECREASE IN SIZE FROM THE DRAIN PAN CONNECTION TO THE FLOOR DRAIN; ELEVATE UNIT TO ACCOMMODATE P-TRAP
- 15 ALL EQUIPMENT AND DEVICES TO BE FURNISHED AND INSTALLED PER THE REQUIREMENTS OF CONTRACT DRAWINGS, SPECIFICATIONS, MANUFACTURERS' RECOMMENDATIONS, AND ACCORDING TO CODE
- 16 ALL EQUIPMENT TO BE TAGGED AND IDENTIFIED ACCORDING TO THE IDENTIFICATION NUMBER OR DESIGNATION ON THE MECHANICAL DRAWING EQUIPMENT SCHEDULES
- 17 ALL HVAC EQUIPMENT SHALL MEET THE REQUIREMENTS OF ASHRAE STANDARD 90.1-2004
- 18 CERTAIN ITEMS SUCH AS RISES AND DROPS IN DUCTWORK, ACCESS DOORS, VOLUME DAMPERS, ETC., ARE INDICATED ON THE CONTRACT DOCUMENT DRAWINGS FOR CLARITY FOR A SPECIFIC LOCATION REQUIREMENT AND SHALL NOT BE INTERPRETED AS THE EXTENT OF THE REQUIREMENTS FOR THESE ITEMS
- 19 UNLESS OTHERWISE DIRECTED IN THESE DOCUMENTS, LOCATE ALL ROOM THERMOSTATS AND HUMIDISTATS 4'-0" (CENTERLINE) AFF. NOTIFY THE ENGINEER OF ANY ROOMS WHERE THE ABOVE LOCATION CANNOT BE MAINTAINED OR WHERE THERE IS A QUESTION ON LOCATION
- 20 ALL DUCTWORK SHALL CLEAR DOORS AND WINDOWS
- 21 ALL AIR HANDLING UNITS SHALL OPERATE WITHOUT MOISTURE CARROVER
- 22 PROVIDE FLEXIBLE CONNECTIONS IN ALL DUCTWORK SYSTEMS (SUPPLY, RETURN, AND EXHAUST) CONNECTED TO AIR HANDLING UNITS, FANS, AND OTHER EQUIPMENT WHICH REQUIRE VIBRATION ISOLATION. FLEXIBLE CONNECTIONS SHALL BE PROVIDED AT THE POINT OF CONNECTION TO THE EQUIPMENT UNLESS OTHERWISE DIRECTED IN THESE DOCUMENTS
- 23 UNLESS OTHERWISE NOTED, ALL DUCTWORK IS OVERHEAD, TIGHT TO UNDERSIDE OF THE STRUCTURE, WITH SPACE FOR INSULATION IF REQUIRED
- 24 RUNS OF FLEXIBLE DUCT SHALL NOT EXCEED 6 FEET
- 25 SMOKE DETECTORS SHALL BE FURNISHED AND WIRED BY THE ELECTRICAL CONTRACTOR. THE MECHANICAL CONTRACTOR SHALL BE RESPONSIBLE FOR MOUNTING THE SMOKE DETECTOR IN DUCTWORK AS SHOWN ON THE DRAWINGS AND IN ACCORDANCE WITH MANUFACTURERS' PRINTED INSTRUCTIONS
- 26 SEE SPECIFICATIONS FOR DUCTWORK GAUGES, BRACING, HANGERS, AND OTHER REQUIREMENTS
- 27 REFER TO HVAC SPECIFICATIONS FOR ADDITIONAL REQUIREMENTS

ARCHITECT

**DOMAIN ARCHITECTURE**

8316 kelwood avenue  
baton rouge, la 70806  
t: 225.216.3770 f: 225.216.3771  
www.domain-dsgn.com

REGISTRATION

CLIENT

Southern University Laboratory School

**BATHROOM RENOVATIONS**

129 SWAN AVE,  
BATON ROUGE, LA 70813

PROJECT INFORMATION

No.	Description	Date

project # C22-0072

date September 5, 2023

director review

MECHANICAL COVER SHEET

**MPO.00**

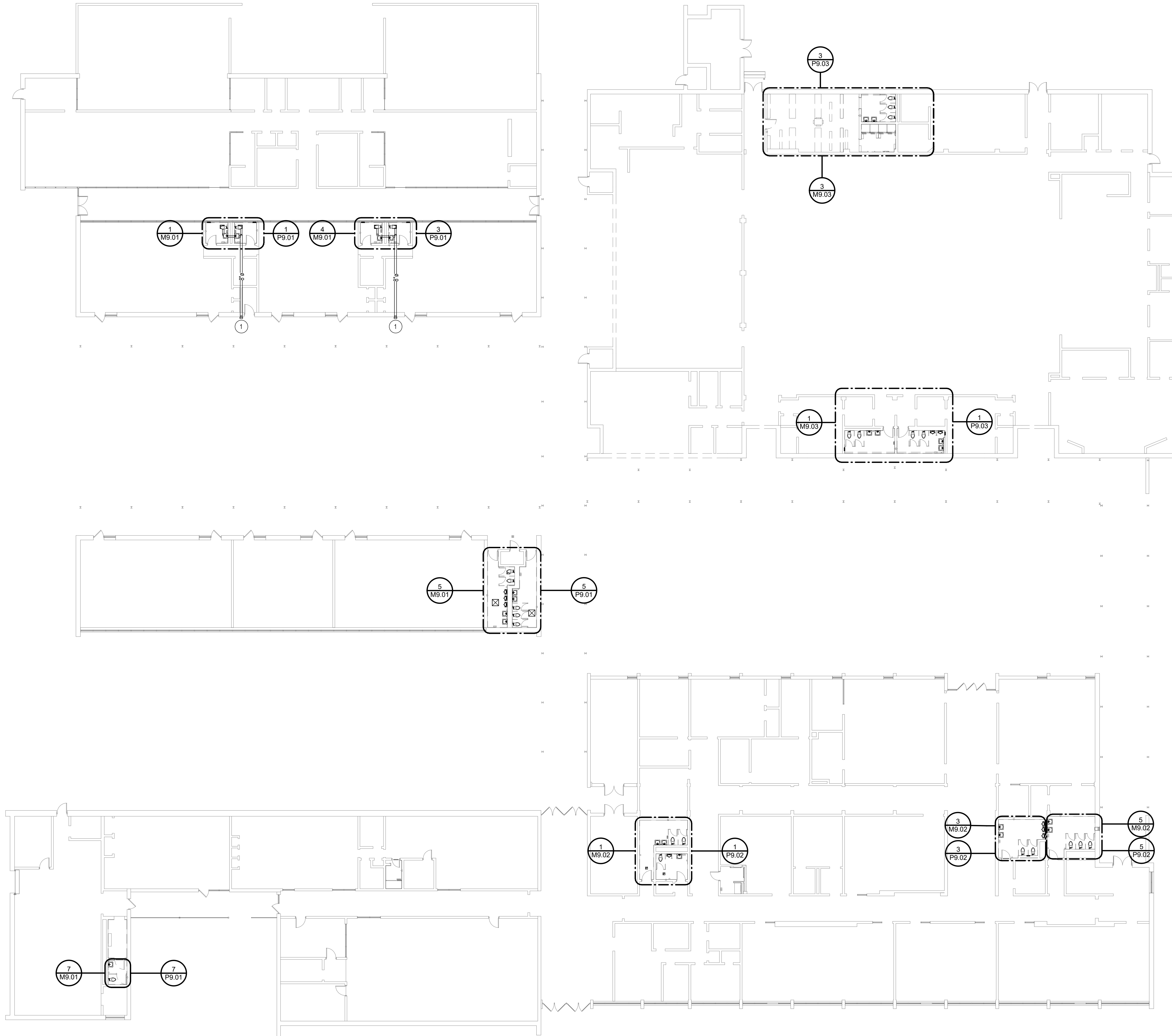

**MECHANICAL PLAN NOTES**

- 1 CONTRACTOR SHALL ROUTE EXHAUST DUCT TO SIDEWALL EXHAUST CAP. CAP SHALL BE SAME SIZE AS DUCT. CONTRACTOR SHALL MAINTAIN A MINIMUM OF 10'-0" CLEAR BETWEEN ANY EXHAUST AND FRESH AIR INTAKE. NO EXCEPTIONS. COORDINATE EXACT LOCATION WITH ARCHITECT.

**1** 1ST FLOOR - MECHANICAL & PLUMBING OVERALL FLOOR PLAN  
1/16" = 1'-0"



These drawings are the property of DOMAIN ARCHITECTURE APAC and are not to be reproduced in whole or in part. They are only to be used for the project and site specifically identified herein. Scales stated hereon are valid on the original drawing only. Contractor shall carefully review all dimensions and conditions shown and report to the architect any errors, inconsistencies, or omissions discovered. These plans were prepared in the office under our personal supervision, and to the best of our knowledge comply with state and local codes. We will generally administer construction.

Southern University Laboratory School  
**BATHROOM RENOVATIONS**

129 SWAN AVE,  
BATON ROUGE, LA 70813

PROJECT INFORMATION

revisions No.	Description	Date

project # C22-0072

date September 5, 2023

director review

1ST FLOOR - MECH & PLUMB  
OVERALL FLOOR PLAN

**MP2.01**

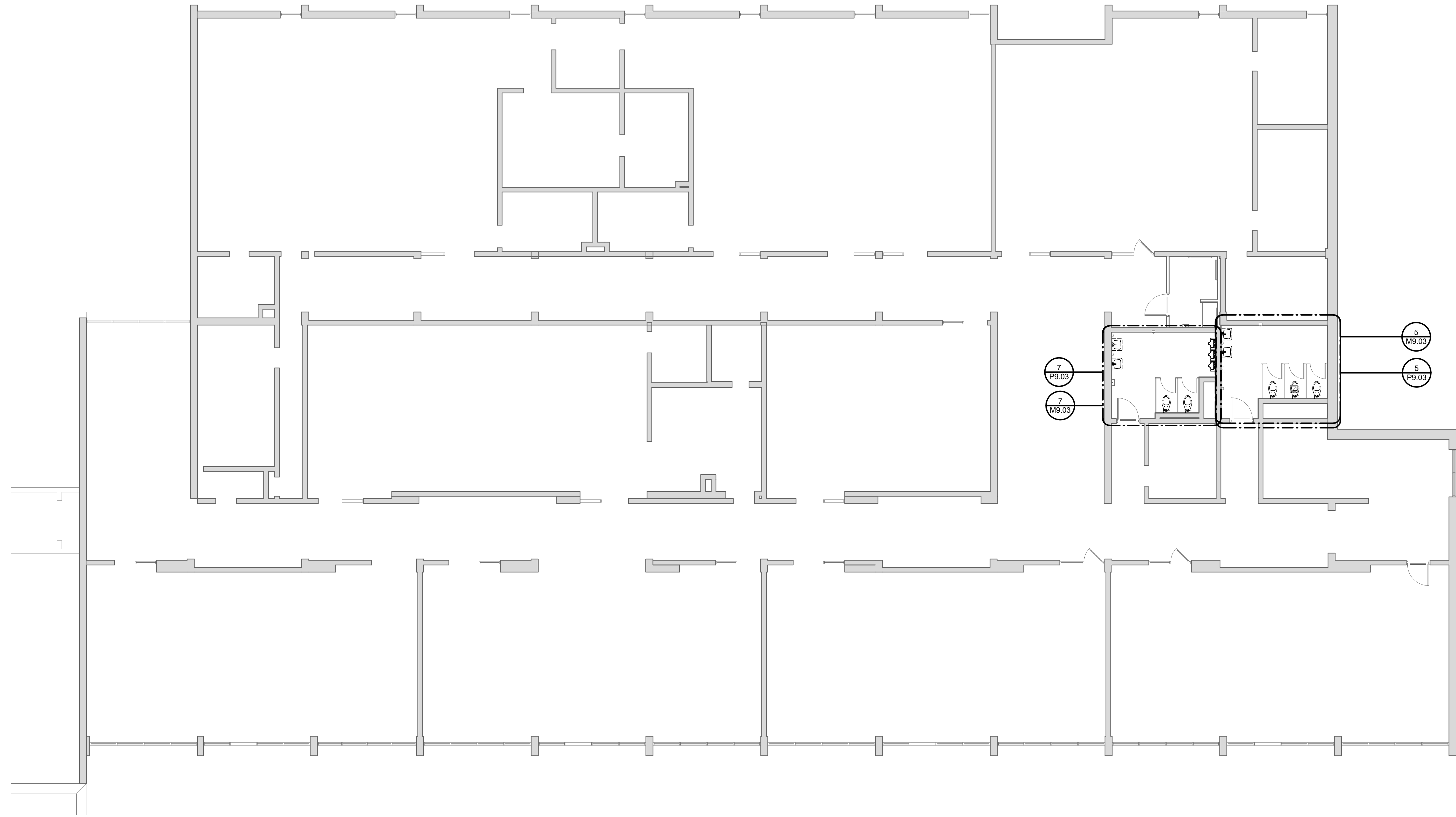

**1** 2ND FLOOR - MECHANICAL & PLUMBING OVERALL FLOOR PLAN  
 1/8" = 1'-0"

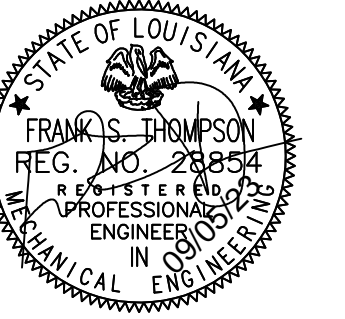

These drawings are the property of DOMAIN ARCHITECTURE APAC and are not to be reproduced in whole or in part. They are only to be used for the project and site specifically identified herein. Scales stated hereon are valid on the original drawing only. Contractor shall carefully review all dimensions and conditions shown and report to the architect any errors, inconsistencies, or omissions discovered. These plans were prepared in the office under our personal supervision, and to the best of our knowledge comply with state and local codes. We will generally administer construction.

Southern University Laboratory School  
**BATHROOM RENOVATIONS**

129 SWAN AVE,  
 BATON ROUGE, LA 70813

revisions	No.	Description	Date

project # C22-0072

date September 5, 2023

director review

2ND FLOOR - MECH & PLUMB  
 OVERALL FLOOR PLAN

**MP2.02**

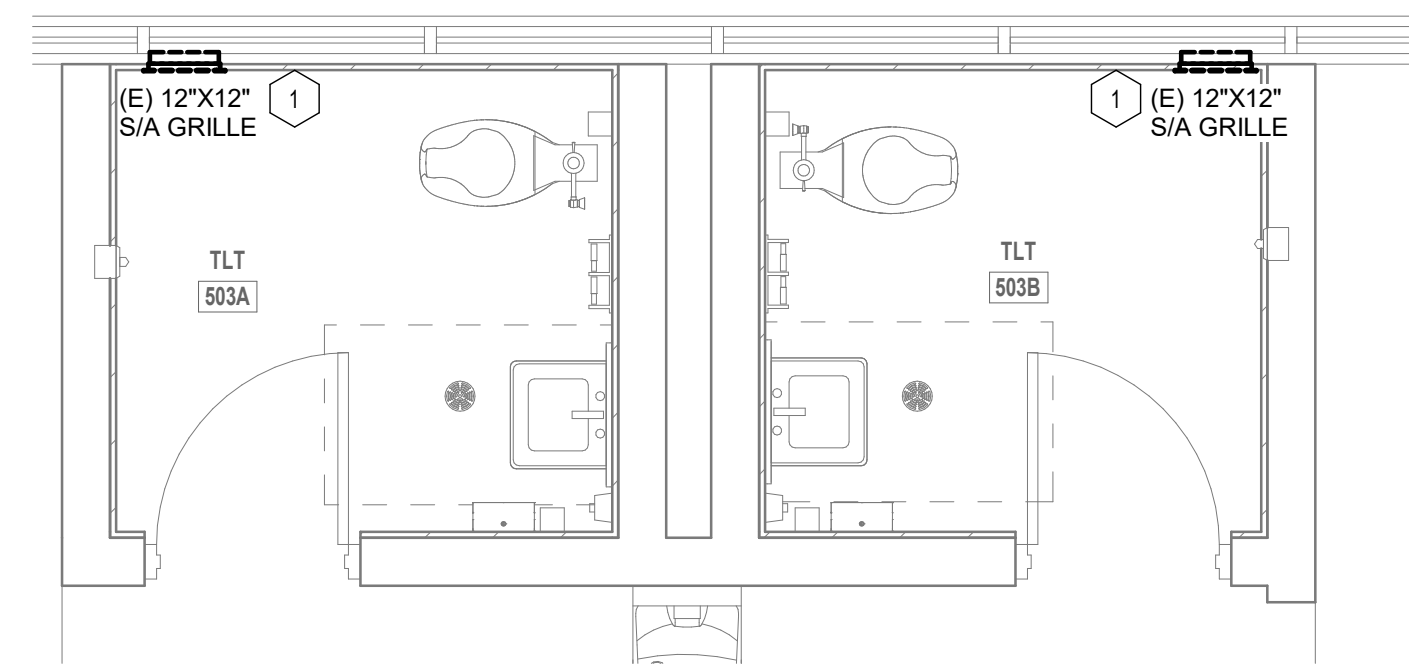

**1** KINDERGARTEN - MECHANICAL DEMOLITION FLOOR PLAN  
3/8" = 1'-0"

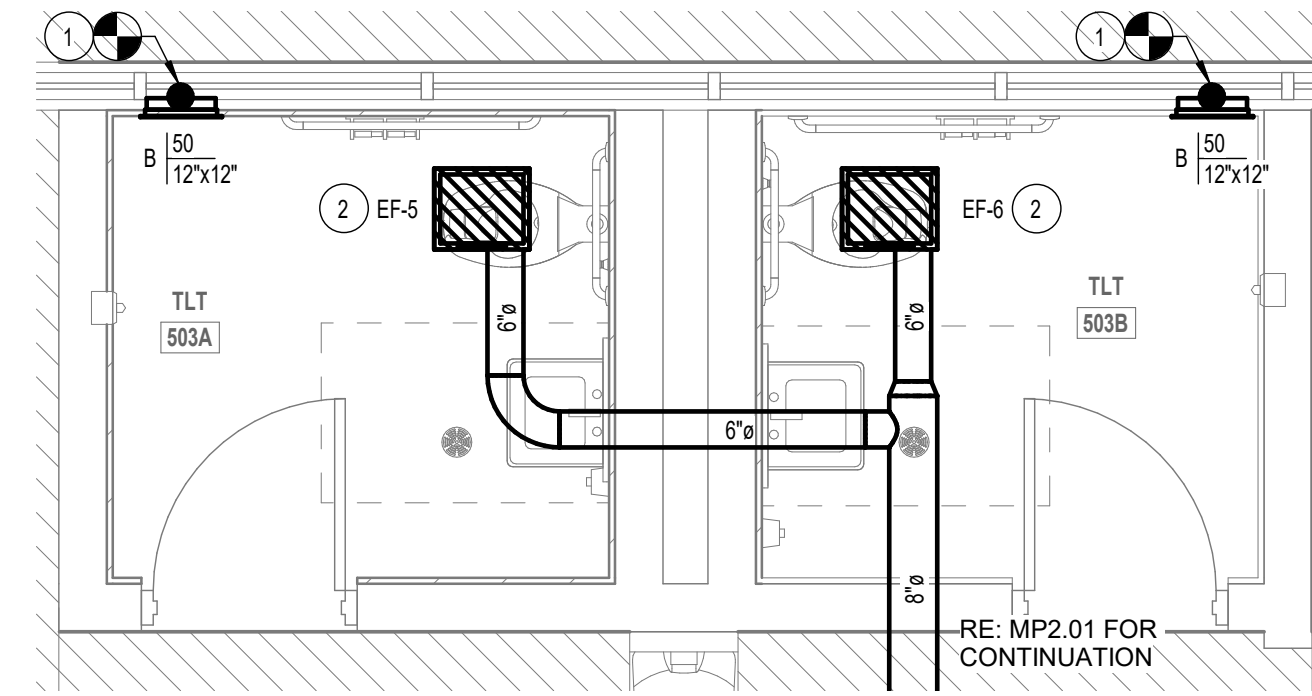

**2** KINDERGARTEN - MECHANICAL FLOOR PLAN  
3/8" = 1'-0"

**MECHANICAL DEMO NOTES**

- 1 REMOVE EXISTING DIFFUSER/GRILLE. PREPARE FOR INSTALLATION OF NEW IN SAME LOCATION.
- 2 REMOVE EXISTING DIFFUSER/GRILLE. PATCH CEILING TO MATCH EXISTING.

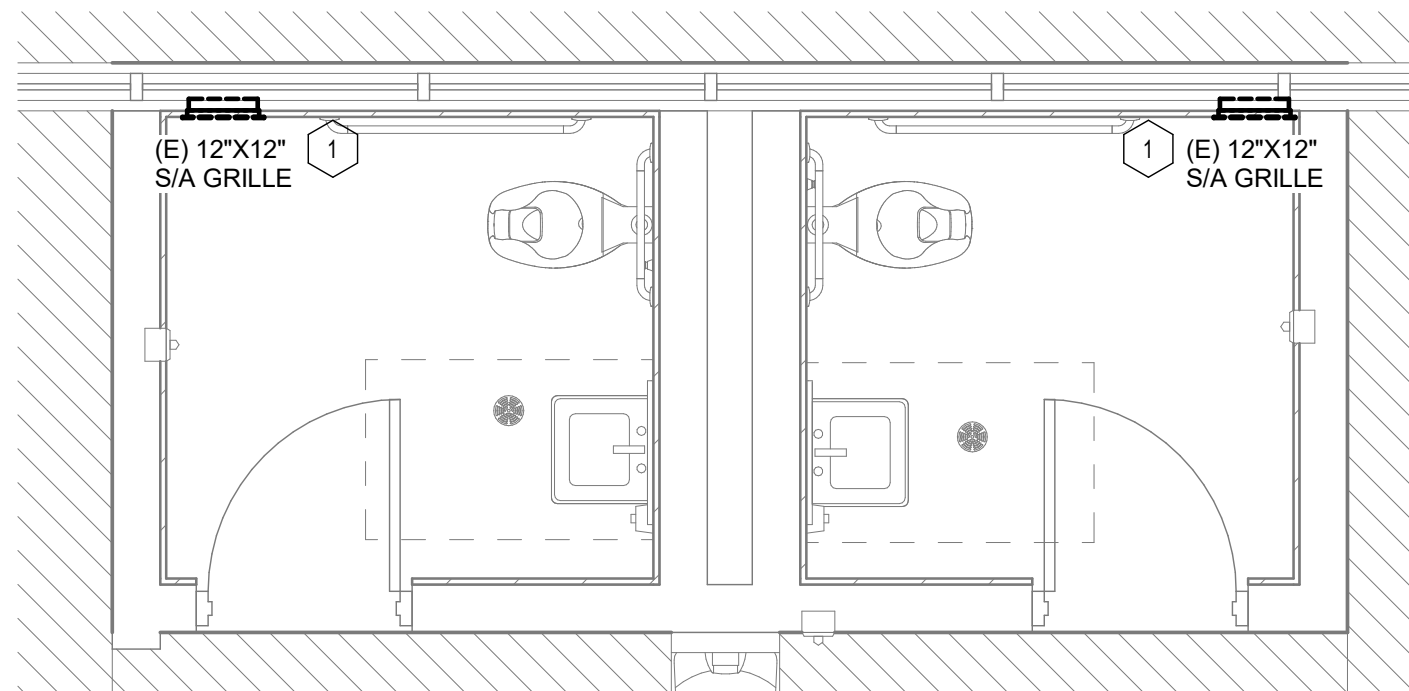

**3** KINDERGARTEN - MECHANICAL DEMOLITION FLOOR PLAN.  
3/8" = 1'-0"

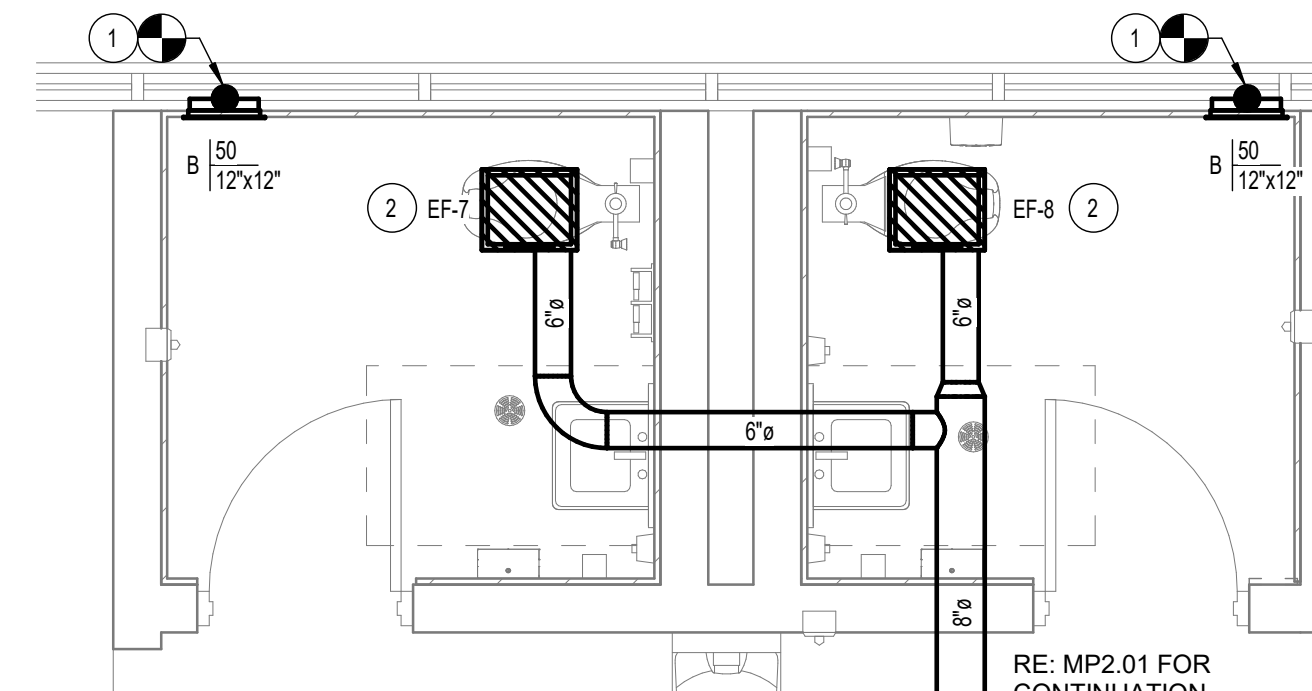

**4** KINDERGARTEN - MECHANICAL FLOOR PLAN  
3/8" = 1'-0"

**MECHANICAL PLAN NOTES**

- 1 NEW DIFFUSER/GRILLE. CONNECT TO EXISTING DUCTWORK. FIELD VERIFY EXACT FACE AND NECK SIZE OF DIFFUSER/GRILLE PRIOR TO ORDERING. BALANCE TO CFM SHOWN.
- 2 CABINET TYPE EXHAUST FAN SUSPENDED FROM STRUCTURE. REFER TO SCHEDULE FOR SIZE AND MODEL. PROVIDE BACKDRAFT DAMPER AT EXHAUST FAN DISCHARGE.

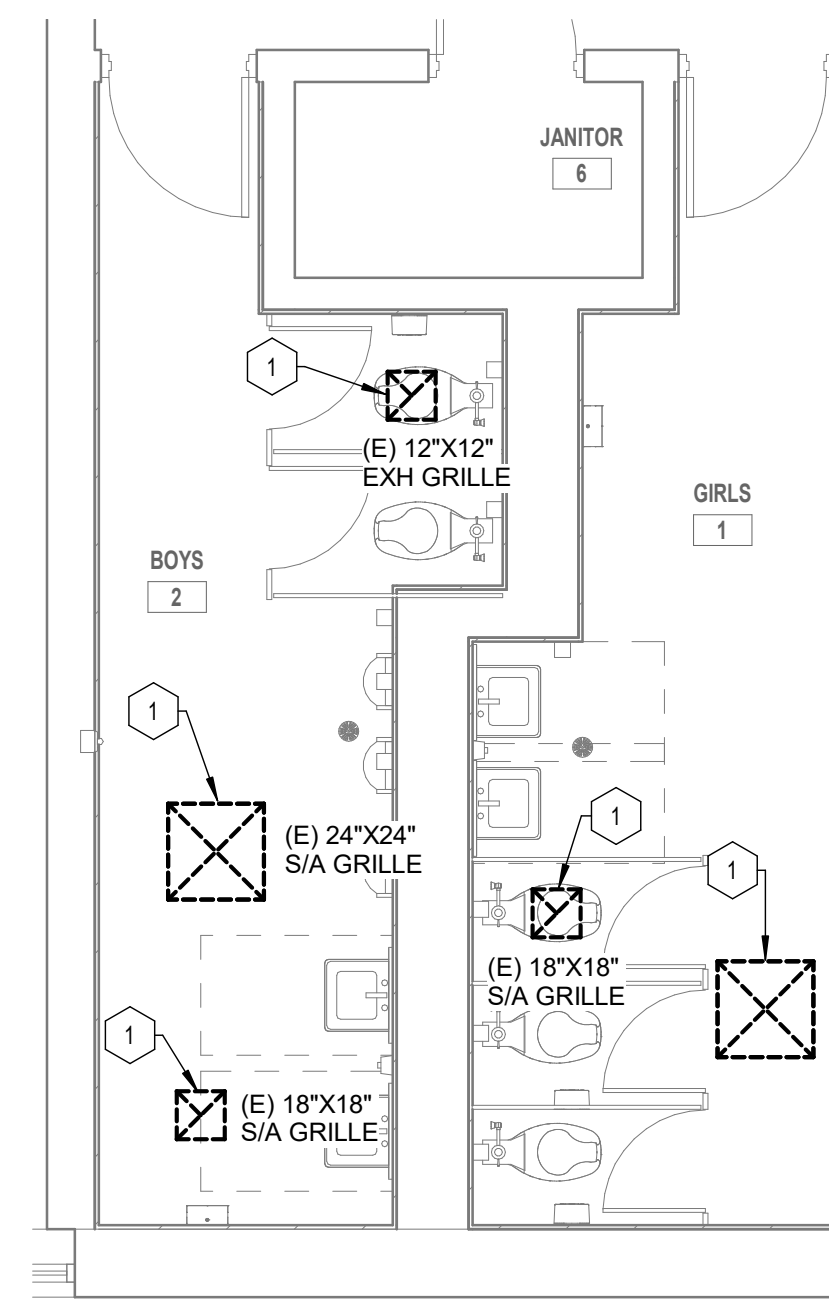

**5** 1ST FLOOR EXTERIOR BATHROOMS - MECHANICAL DEMOLITION FLOOR PLAN  
1/4" = 1'-0"

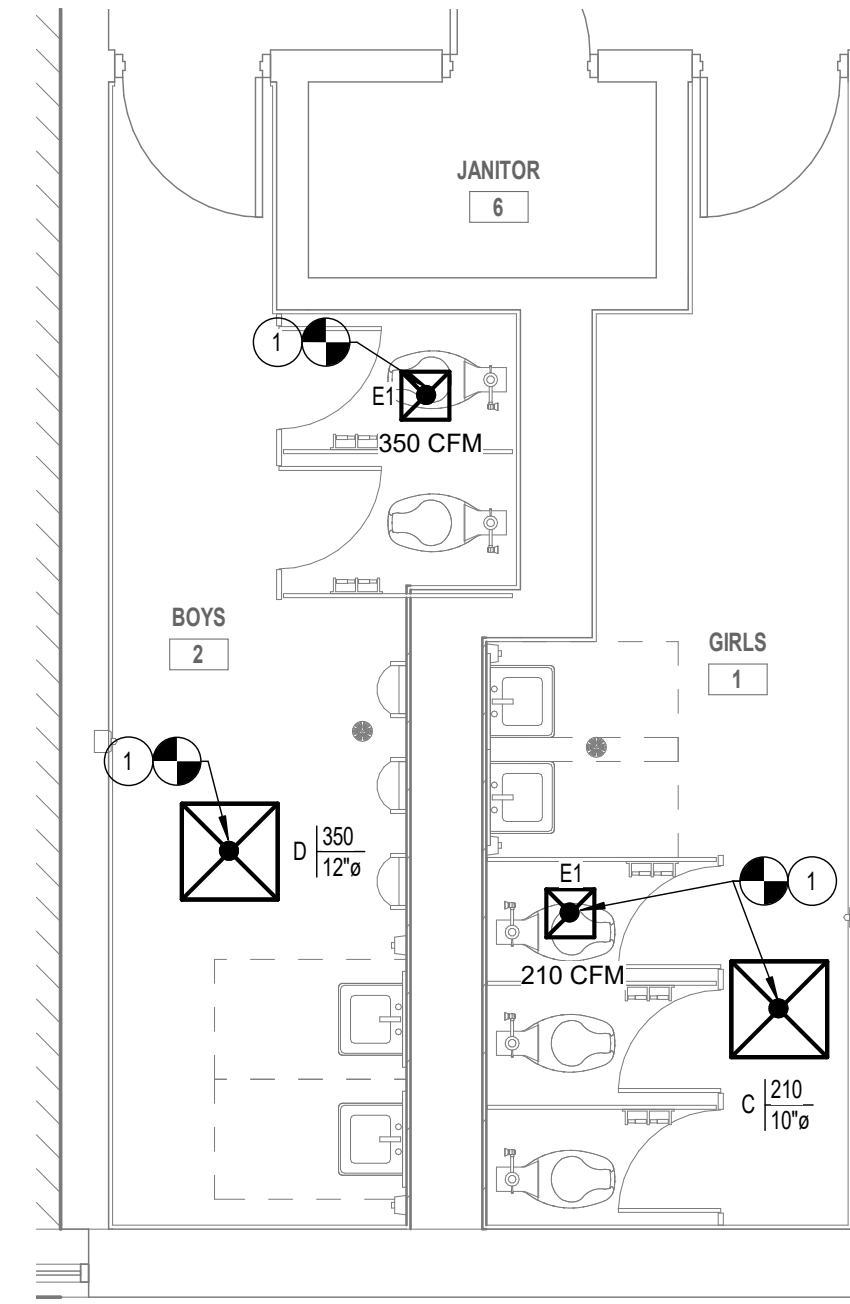

**6** 1ST FLOOR EXTERIOR BATHROOMS - MECHANICAL FLOOR PLAN  
1/4" = 1'-0"

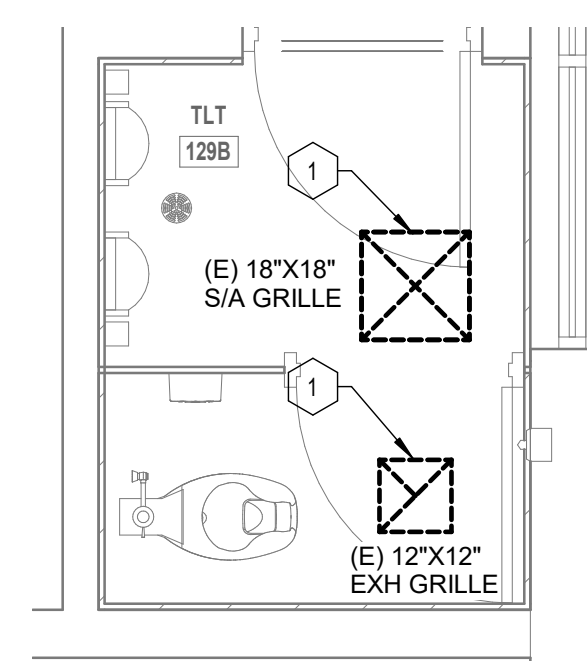

**7** ART CLASSROOM - MECHANICAL DEMOLITION FLOOR PLAN  
3/8" = 1'-0"

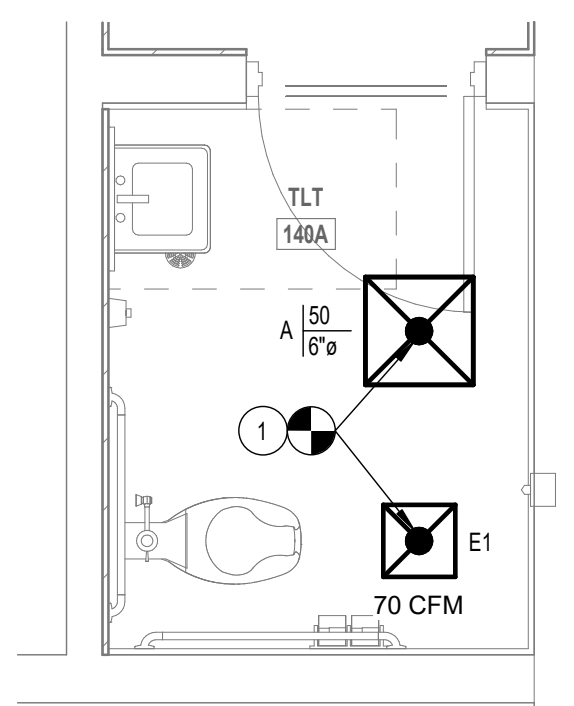

**8** ART CLASSROOM - MECHANICAL FLOOR PLAN  
3/8" = 1'-0"

ARCHITECT

**DOMAIN ARCHITECTURE**

8316 kelwood avenue, baton rouge, la 70806  
t: 225.216.3770 f: 225.216.3771  
www.domain-dsgn.com

REGISTRATION

These drawings are the property of DOMAIN ARCHITECTURE APAC and are not to be reproduced in whole or in part. They are only to be used for the project and site specifically identified herein. Scales stated herein are valid on the original drawing only. Contractor shall carefully review all dimensions and conditions shown and report to the architect any errors, inconsistencies, or omissions discovered. These plans were prepared in the office under our personal supervision, and to the best of our knowledge comply with state and local codes. We will generally administer construction.

CLIENT

Southern University Laboratory School  
**BATHROOM RENOVATIONS**

129 SWAN AVE,  
BATON ROUGE, LA 70813

PROJECT INFORMATION

revisions	No.	Description	Date

project # C22-0072  
date September 5, 2023  
director review

ENLARGED  
MECHANICAL PLANS

**M9.01**

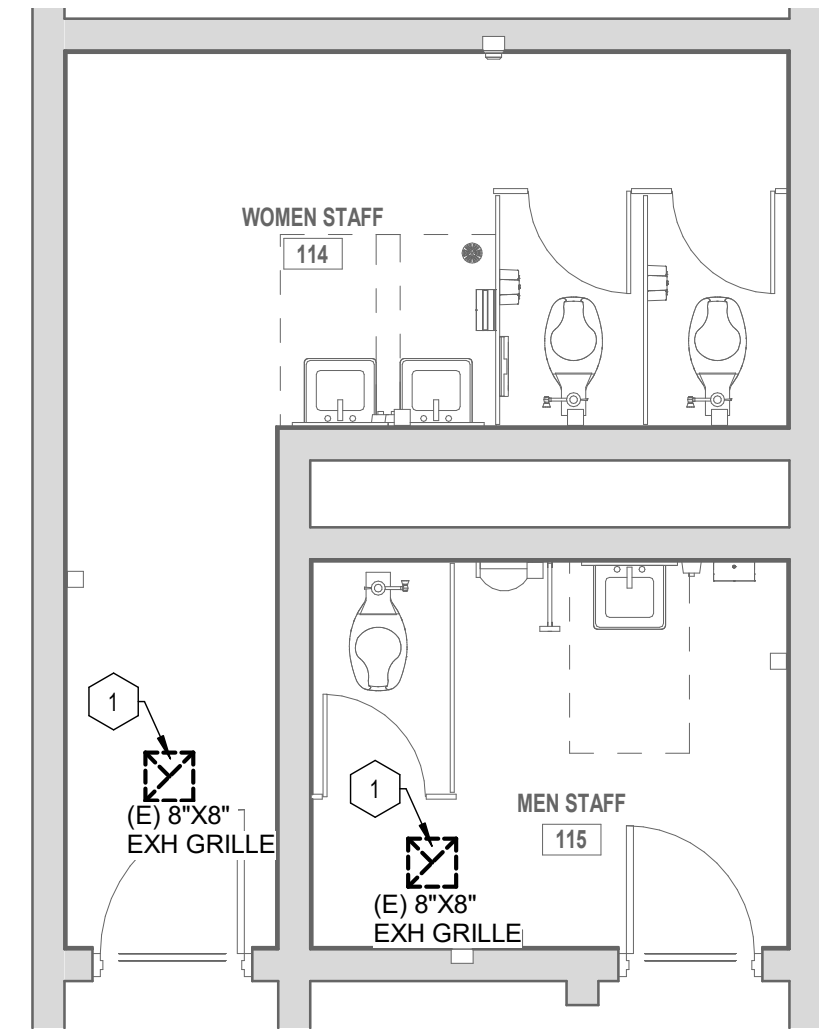

**1** 1ST FLOOR STAFF - MECHANICAL DEMOLITION FLOOR PLAN  
1/4" = 1'-0"

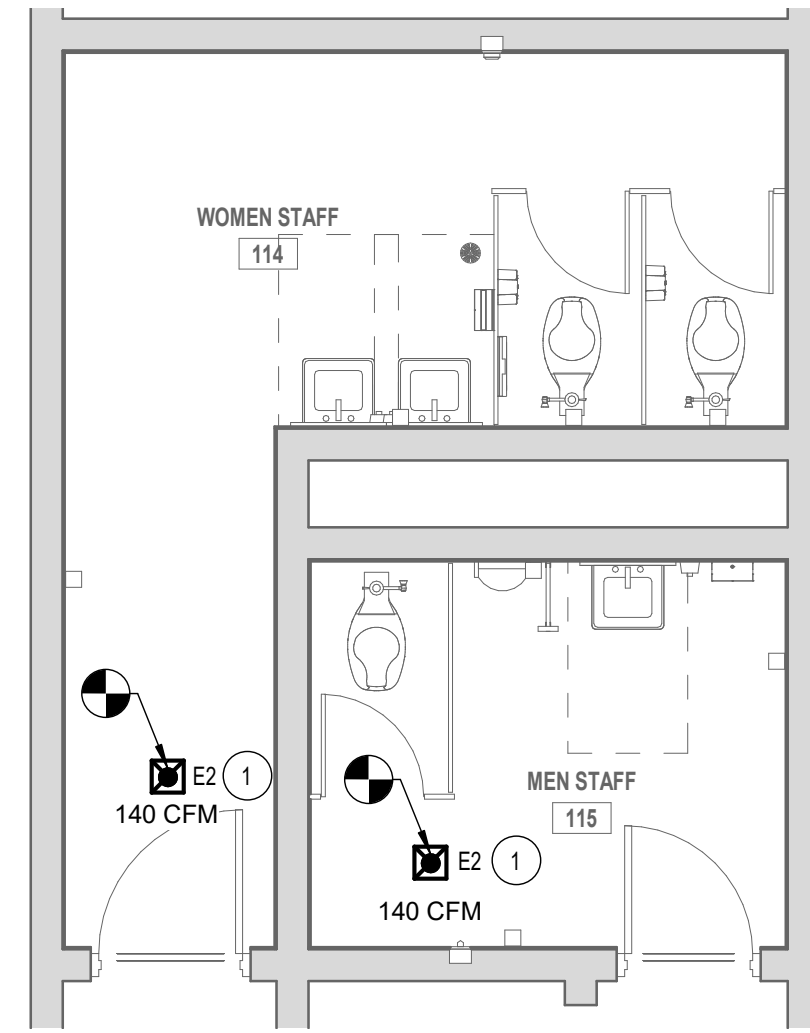

**2** 1ST FLOOR STAFF - MECHANICAL FLOOR PLAN  
1/4" = 1'-0"

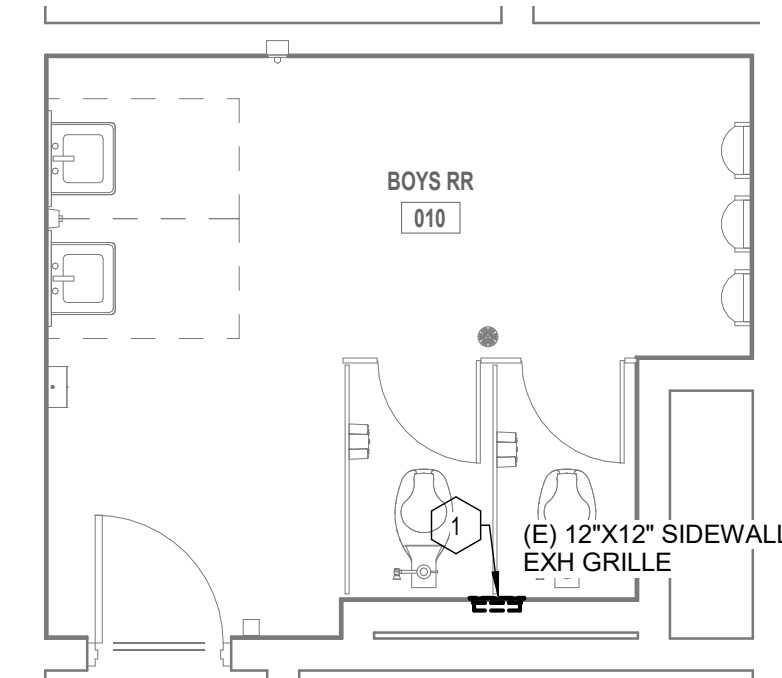

**3** 1ST FLOOR BOYS - MECHANICAL DEMOLITION FLOOR PLAN  
1/4" = 1'-0"

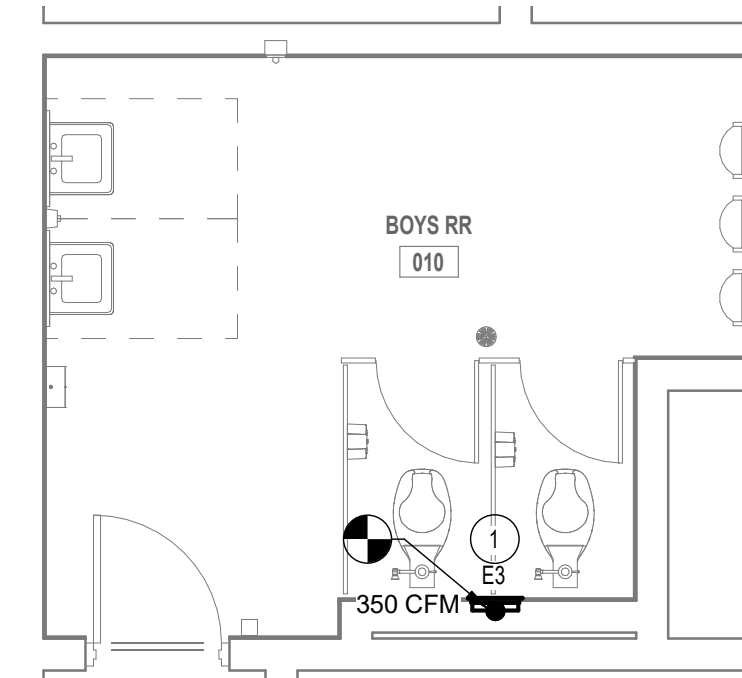

**4** 1ST FLOOR BOYS - MECHANICAL FLOOR PLAN  
1/4" = 1'-0"

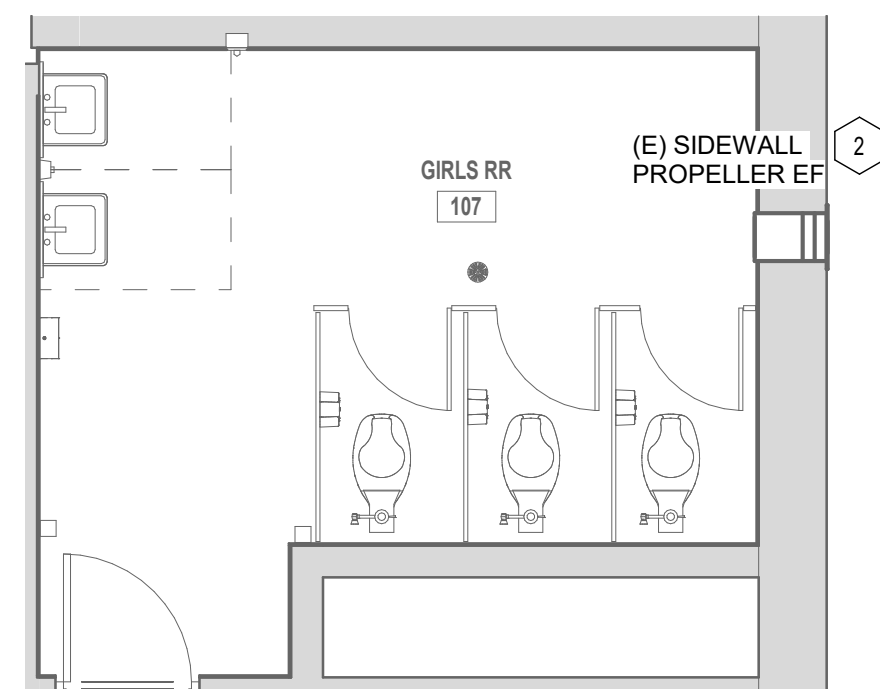

**5** 1ST FLOOR GIRLS - MECHANICAL DEMOLITION FLOOR PLAN  
1/4" = 1'-0"

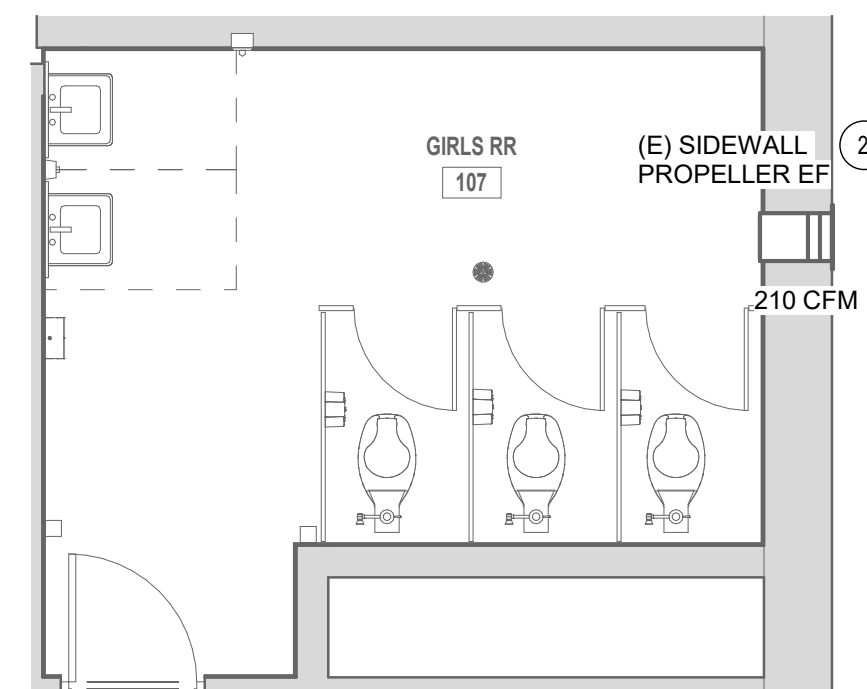

**6** 1ST FLOOR GIRLS - MECHANICAL FLOOR PLAN  
1/4" = 1'-0"

**MECHANICAL DEMO NOTES**

- 1 REMOVE EXISTING DIFFUSER/GRILLE. PREPARE FOR INSTALLATION OF NEW IN SAME LOCATION.
- 2 EXISTING SIDEWALL PROPELLER EXHAUST FAN TO REMAIN.

**MECHANICAL PLAN NOTES**

- 1 NEW DIFFUSER/GRILLE. CONNECT TO EXISTING DUCTWORK. FIELD VERIFY EXACT FACE AND NECK SIZE OF DIFFUSER/GRILLE PRIOR TO ORDERING. BALANCE TO CFM SHOWN.
- 2 CLEAN AND SERVICE EXISTING SIDEWALL PROPELLER EXHAUST FAN. BALANCE TO CFM SHOWN.

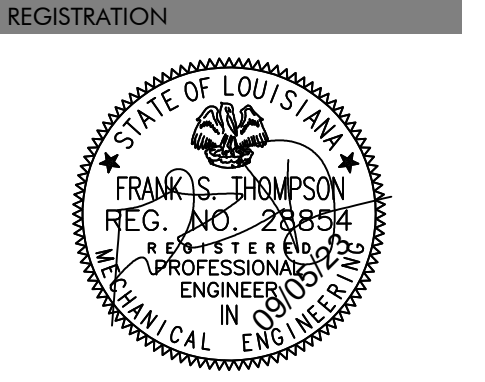

These drawings are the property of DOMAIN ARCHITECTURE APC and are not to be reproduced in whole or in part. They are only to be used for the project and site specifically identified herein. Scales stated herein are valid on the original drawings only. Contractor shall carefully review all dimensions and conditions shown and report to the architect any errors, inconsistencies, or omissions discovered. These plans were prepared in the office under our personal supervision, and to the best of our knowledge comply with state and local codes. We will generally administer construction.

CLIENT

Southern University Laboratory School  
**BATHROOM RENOVATIONS**

129 SWAN AVE,  
BATON ROUGE, LA 70813

PROJECT INFORMATION

revisions	No.	Description	Date

project # C22-0072

date September 5, 2023

director review

ENLARGED  
MECHANICAL PLANS

**M9.02**

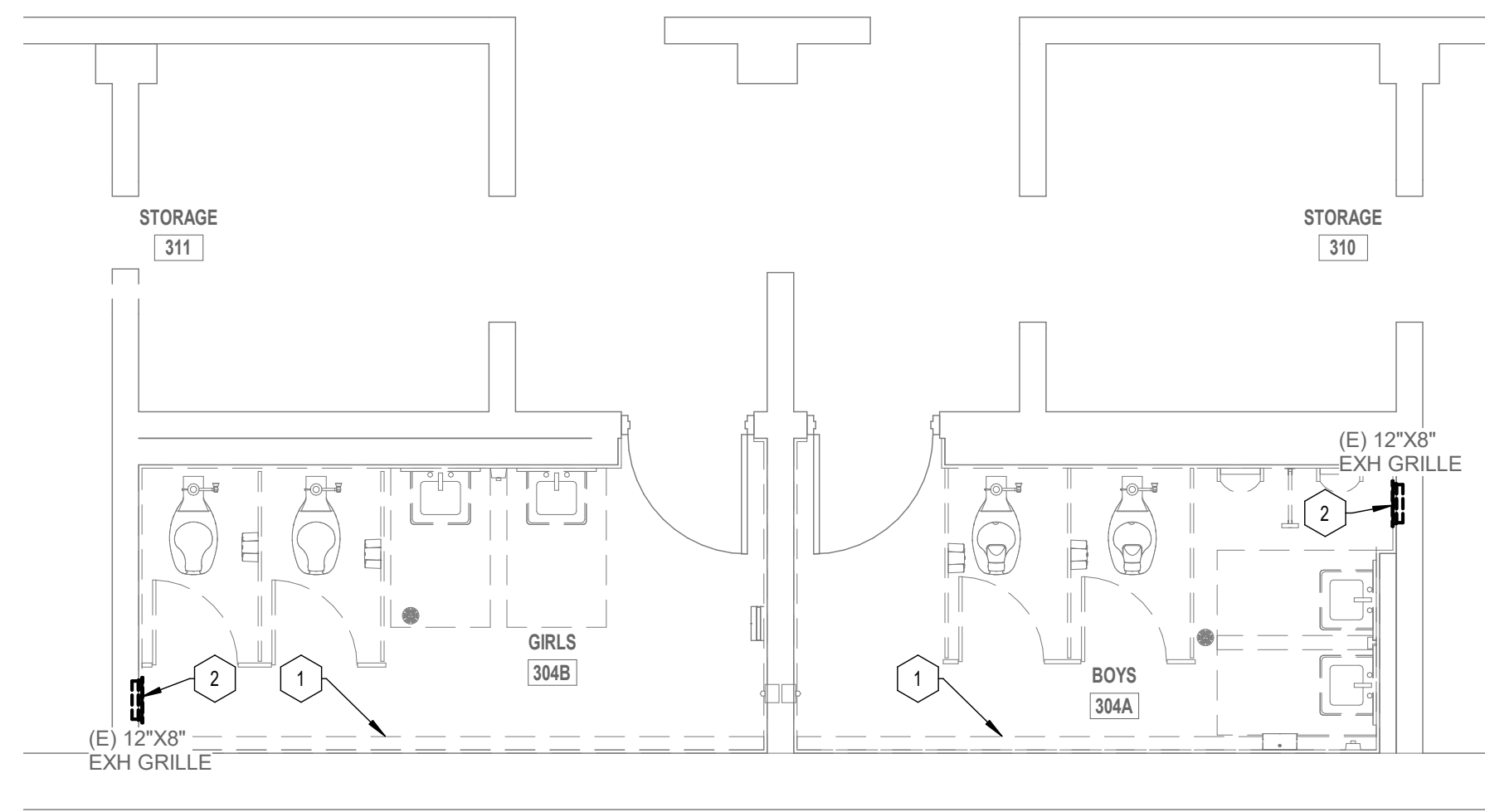

**1 | 1ST FLOOR GYM - MECHANICAL DEMOLITION FLOOR PLAN**  
1/4" = 1'-0"

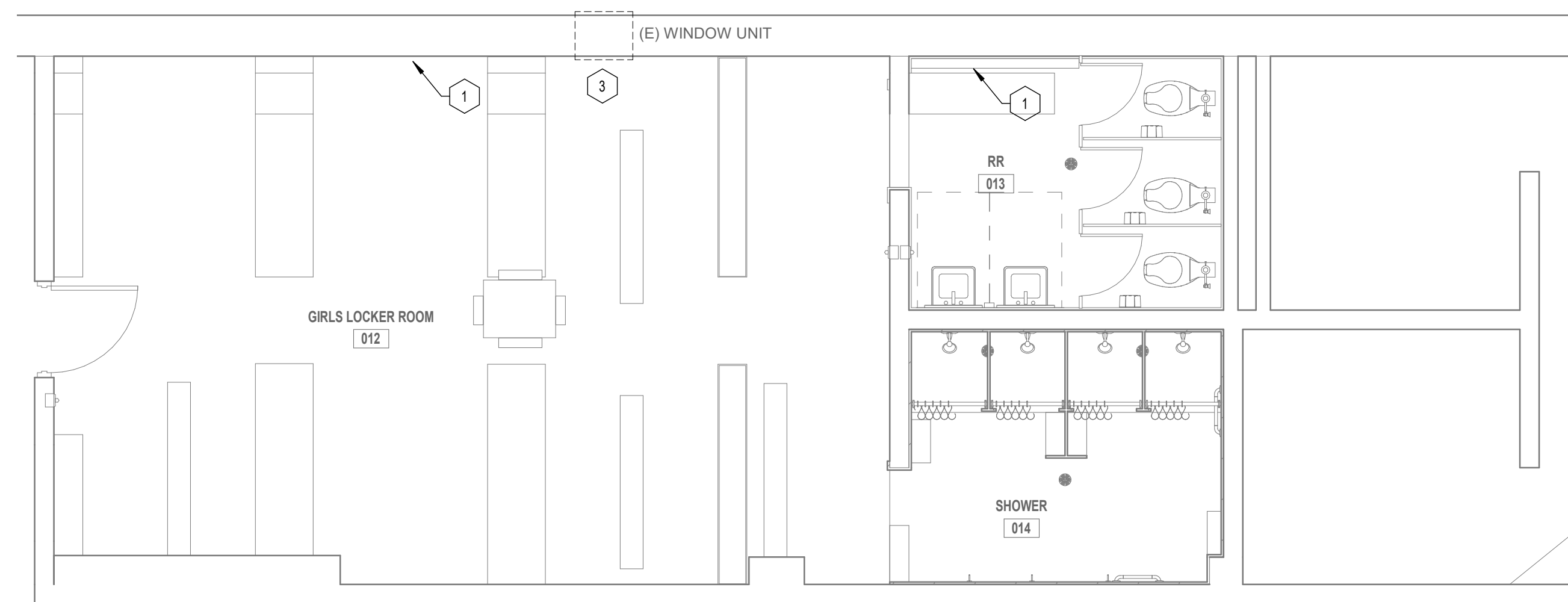

**3 | ENLG 1ST FLOOR - B - NEW LOCKER ROOM MECHANICAL DEMOLITION FLOOR PLAN**  
1/4" = 1'-0"

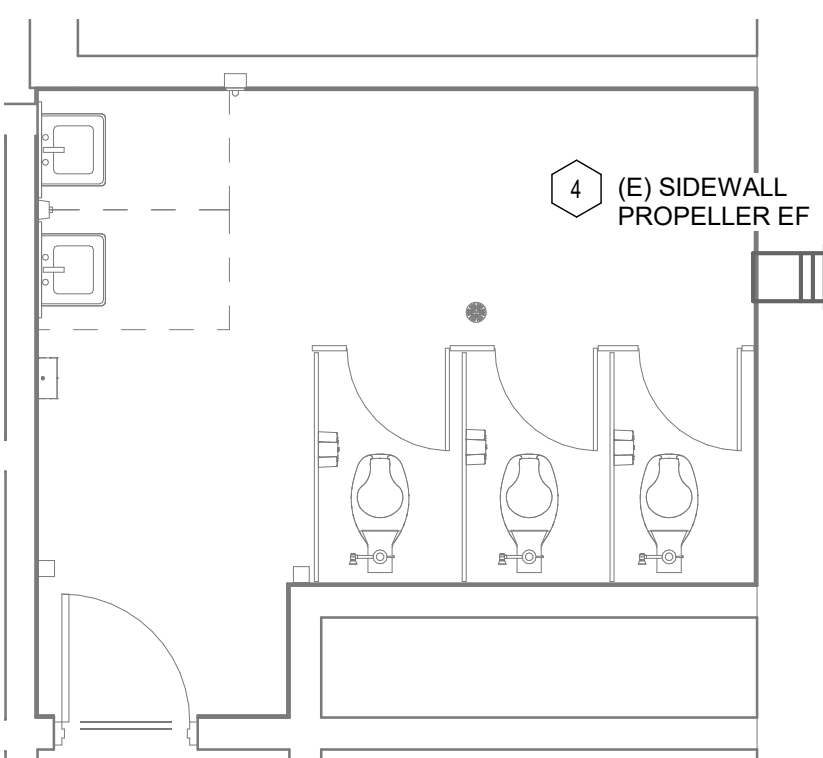

**5 | 2ND FLOOR GIRLS - MECHANICAL DEMOLITION FLOOR PLAN**  
1/4" = 1'-0"

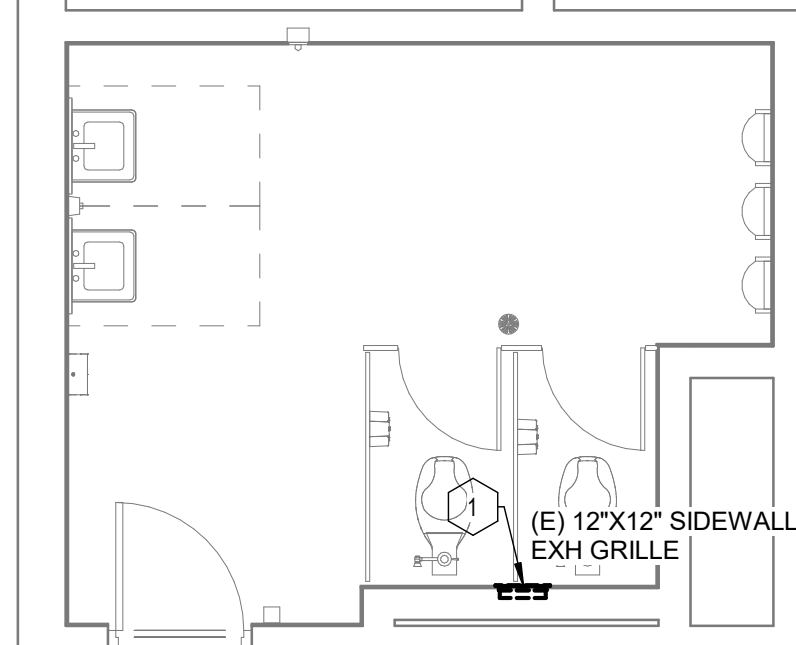

**7 | 2ND FLOOR BOYS - MECHANICAL DEMOLITION FLOOR PLAN**  
1/4" = 1'-0"

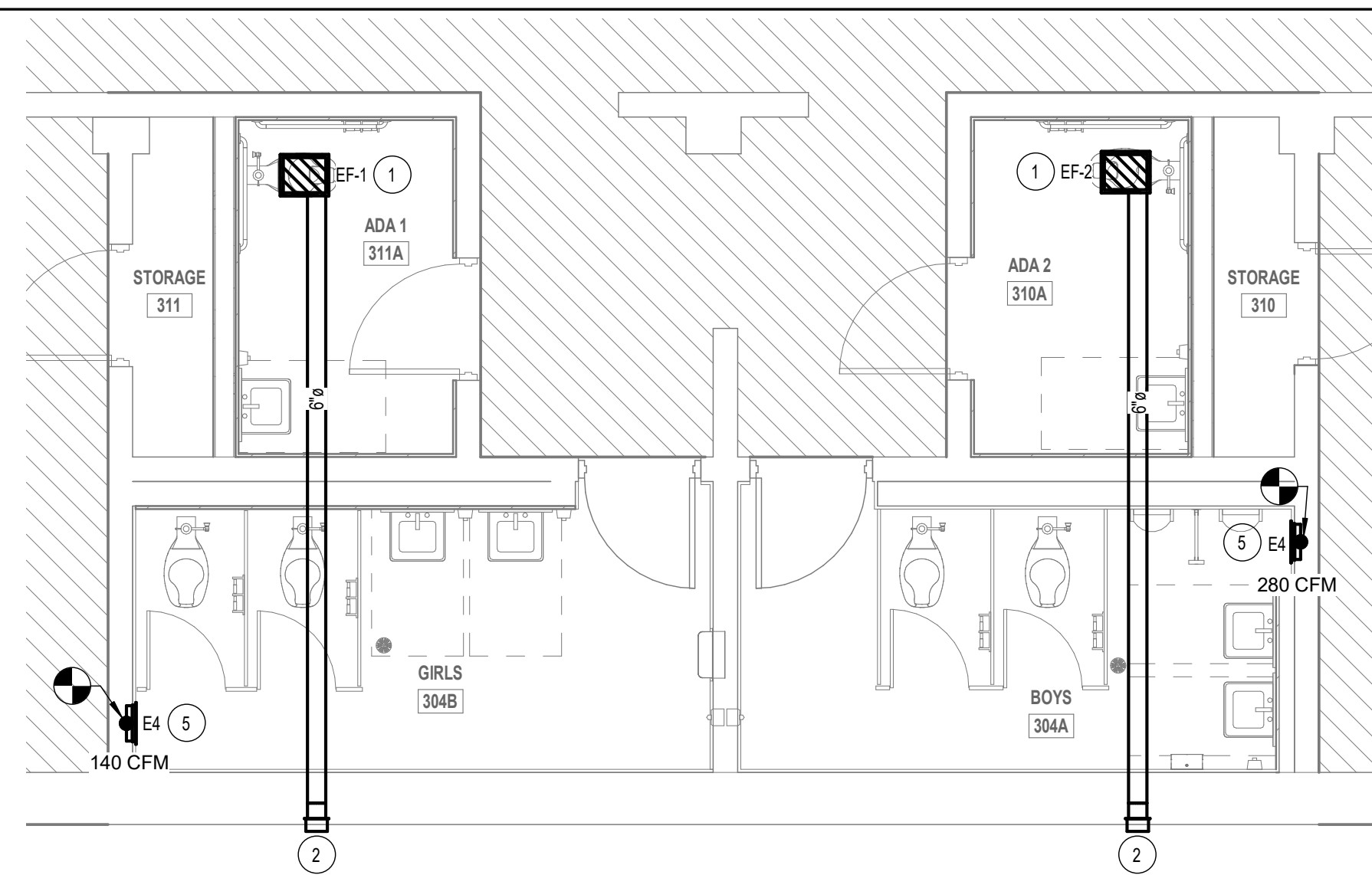

**2 | 1ST FLOOR GYM - MECHANICAL FLOOR PLAN**  
1/4" = 1'-0"

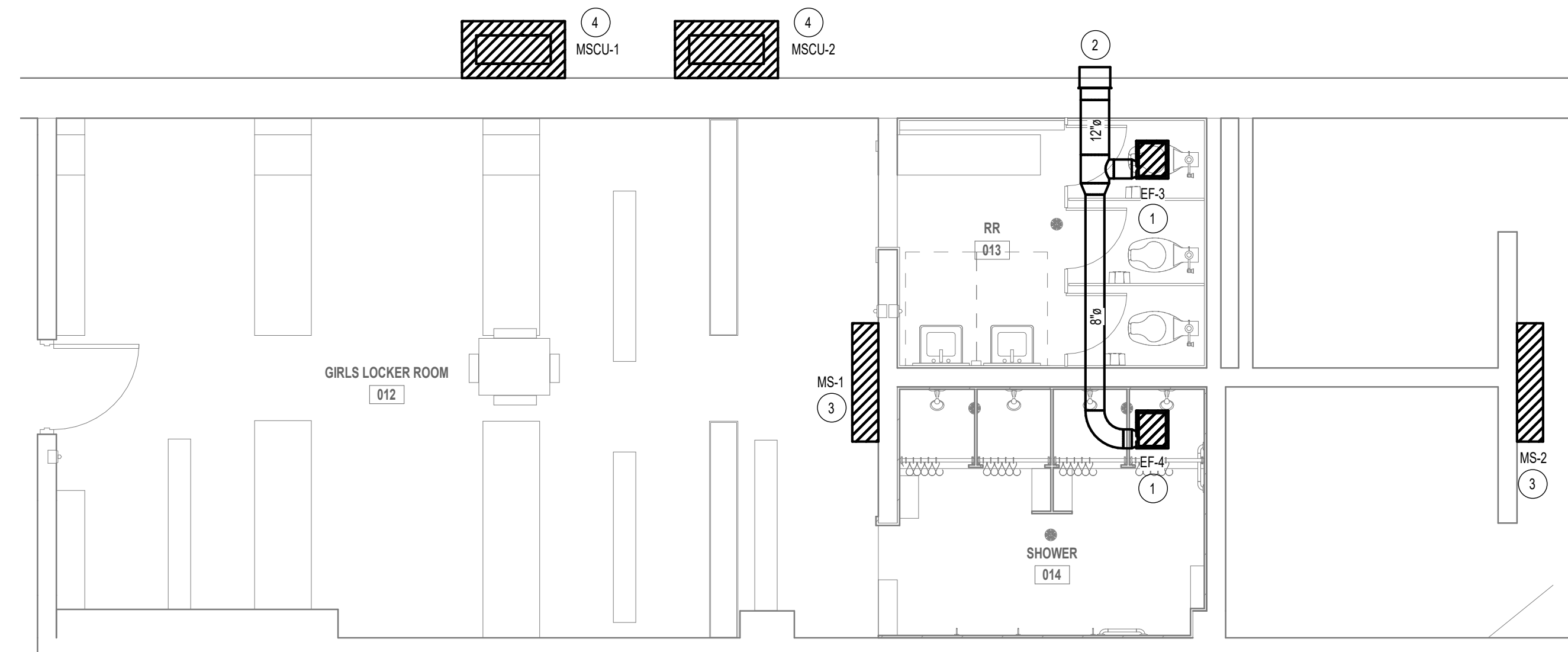

**4 | ENLG 1ST FLOOR - B - NEW LOCKER ROOM MECHANICAL FLOOR PLAN**  
1/4" = 1'-0"

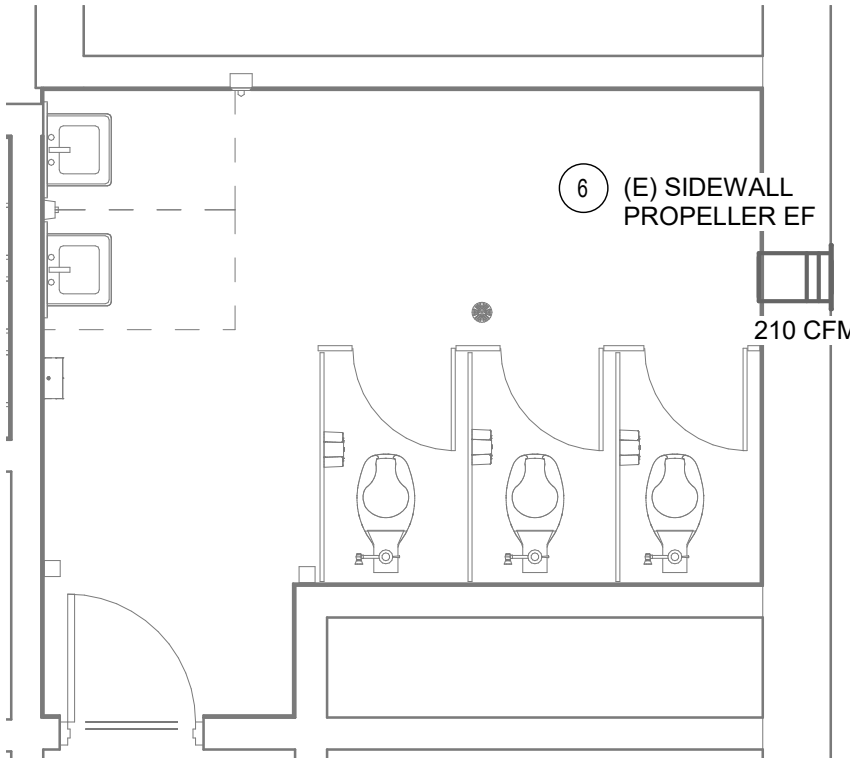

**6 | 2ND FLOOR GIRLS - MECHANICAL FLOOR PLAN**  
1/4" = 1'-0"

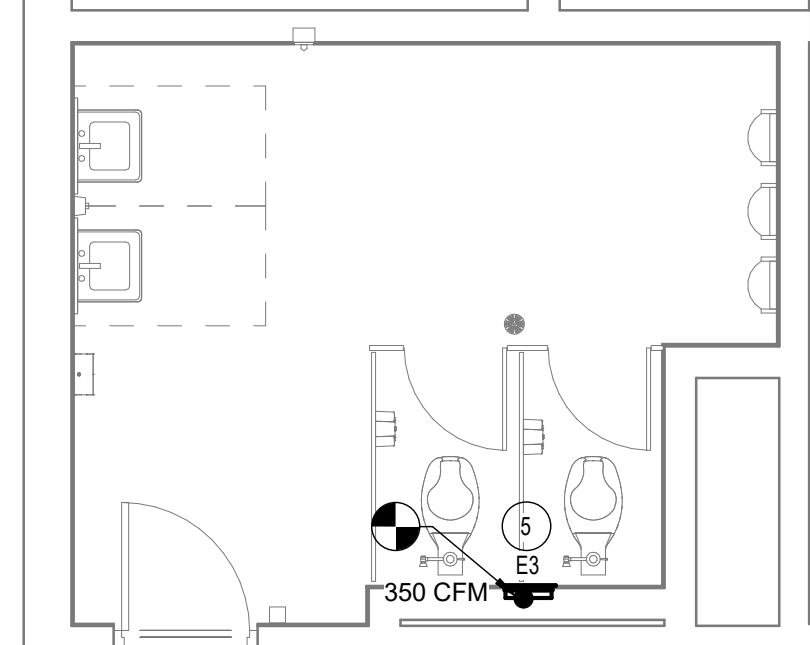

**8 | 2ND FLOOR BOYS - MECHANICAL FLOOR PLAN**  
1/4" = 1'-0"

**MECHANICAL DEMO NOTES**

- 1 REMOVE EXISTING RADIANT WALL HEATERS AND ALL ASSOCIATED COMPONENTS. CAP ALL SERVICE CONNECTIONS.
- 2 REMOVE EXISTING DIFFUSER/GRILLE. PREPARE FOR INSTALLATION OF NEW IN SAME LOCATION.
- 3 REMOVE EXISTING WINDOW UNIT. PATCH TO MATCH EXISTING.
- 4 EXISTING SIDEWALL PROPELLER EXHAUST FAN TO REMAIN.

**MECHANICAL PLAN NOTES**

- 1 CABINET TYPE EXHAUST FAN SUSPENDED FROM STRUCTURE. REFER TO SCHEDULE FOR SIZE AND MODEL. PROVIDE BACKDRAFT DAMPER AT EXHAUST FAN DISCHARGE.
- 2 CONTRACTOR SHALL ROUTE EXHAUST DUCT TO SIDEWALL EXHAUST CAP. CAP SHALL BE SAME SIZE AS DUCT. CONTRACTOR SHALL MAINTAIN A MINIMUM OF 10'-0" CLEAR BETWEEN ANY EXHAUST AND FRESH AIR INTAKE, NO EXCEPTIONS. COORDINATE EXACT LOCATION WITH ARCHITECT.
- 3 WALL-MOUNTED MINISPLIT AIR HANDLER. MOUNT AS HIGH AS POSSIBLE. ROUTE REFRIGERANT LINES THROUGH STRAIGHT ALONG WALL AND THROUGH EXTERIOR WALL TO ASSOCIATED MINISPLIT CONDENSING UNIT. ROUTE 1" INSULATED CONDENSATE LINE TO HUB DRAIN IN WALL. REFER TO PLUMBING PLAN.
- 4 MINISPLIT CONDENSING UNIT MOUNTED ON 4" HOUSEKEEPING PAD IN MECHANICAL YARD. COORDINATE WITH ARCHITECT FOR EXACT LOCATION OF YARD. UNITS SHALL BE LOCATED A MINIMUM OF 18" OFF OF ANY EXTERIOR WALL AND A MINIMUM OF 24" APART. ROUTE REFRIGERANT LINES THROUGH WALL AND ALONG INTERIOR WALL TO ASSOCIATED WALL-MOUNTED MINISPLIT AIR HANDLER.
- 5 NEW DIFFUSER/GRILLE. CONNECT TO EXISTING DUCTWORK. FIELD VERIFY EXACT FACE AND NECK SIZE OF DIFFUSER/GRILLE PRIOR TO ORDERING. BALANCE TO CFM SHOWN.
- 6 CLEAN AND SERVICE EXISTING SIDEWALL PROPELLER EXHAUST FAN. BALANCE TO CFM SHOWN.

ARCHITECT

**DOMAIN**  
ARCHITECTURE

8316 kelwood avenue  
baton rouge, la 70806  
t: 225.216.3770 f: 225.216.3771  
www.domain-dsgn.com

REGISTRATION

These drawings are the property of DOMAIN ARCHITECTURE APC and are not to be reproduced in whole or in part. They are only to be used for the project and site specifically identified herein. Scales stated herein are valid on the original drawings only. Contractor shall carefully review all dimensions and conditions shown and report to the architect any errors, inconsistencies, or omissions discovered. These plans were prepared in this office under our personal supervision, and to the best of our knowledge comply with state and local codes. We will generally administer construction.

CLIENT

Southern University Laboratory School  
**BATHROOM RENOVATIONS**

129 SWAN AVE,  
BATON ROUGE, LA 70813

PROJECT INFORMATION

revisions	No.	Description	Date

project # C22-0072  
date September 5, 2023  
director review



**AIR HANDLING UNIT SCHEDULE**

- NOTES:
- CAPACITIES SHALL BE IN ACCORDANCE WITH ARI STANDARD 210/240: (A) COOLING: 80°F DB / 67°F WB ENTERING INDOOR COIL; 95°F ENTERING OUTDOOR COIL AT PUBLISHED NOMINAL CFM (B) LOW TEMPERATURE HEATING: 17°F DB / 15°F WB ENTERING OUTDOOR COIL; 70°F ENTERING INDOOR COIL AT PUBLISHED NOMINAL...
  - EXTERNAL STATIC PRESSURE LOSSES DO NOT ACCOUNT FOR DIRTY FILTER
  - CONDENSATE SHALL BE GRAVITY FED TO NEAREST HUB DRAIN WITH P-TRAP; REFER TO PLUMBING PLAN.
  - CONTRACTOR SHALL VERIFY VOLTAGE REQUIREMENTS WITH ELECTRICAL CONTRACTOR PRIOR TO ORDERING.

MARK	LOCATION	DESCRIPTION	NOMINAL TONS	EVAPORATOR COIL			ELECTRIC SERVICE				ACCEPTABLE MANUFACTURERS	NOTES	
				TOT CAP	COOLING	SEN CAP	HEATING	VOLTS	PH	FREQ			MCA
MS-1	GIRLS LOCKER ROOM	SINGLE ZONE MINISPLIT AIR HANDLER	3	34400 Btu/h	22160 Btu/h	36000 Btu/h	208 V	3	60 Hz	19.8 A	20 A	DAIKIN FTX SERIES; MITSUBISHI OR LG APPROVED EQUAL	1,2,3,4
MS-2	BOYS LOCKER ROOM	SINGLE ZONE MINISPLIT AIR HANDLER	3	34400 Btu/h	22160 Btu/h	36000 Btu/h	208 V	3	60 Hz	19.8 A	20 A	DAIKIN FTX SERIES; MITSUBISHI OR LG APPROVED EQUAL	1,2,3,4

**CONDENSER SCHEDULE**

- NOTES:
- CONDENSING UNIT SHALL BE SECURED TO CONCRETE HOUSEKEEPING PAD; RE: SPECS.
  - UNIT SHALL BE PROVIDED WITH LOW AMBIENT KIT.

MARK	SERVIC E	NOMINAL TONS	CAPACITY		COMPRESSOR			CONDENSER FAN		ELECTRIC SERVICE				ACCEPTABLE MANUFACTURERS	NOTES		
			COOLING	HEATING	REF. TYPE	QTY.	RLA	QTY.	POWER	FLA EA	VOLTS	PH	FREQ			MCA	MOCP
MSCU-1	MS-1	3	34400 Btu/h	36000 Btu/h	R-410A	1	18 A	1	0.16 hp	0.83 A	208 V	1	60 Hz	19.8 A	20 A	DAIKIN RX36NMVJU; DAIKIN OR LG APPROVED EQUAL	1,2
MSCU-2	MS-1	3	34400 Btu/h	36000 Btu/h	R-410A	1	18 A	1	0.16 hp	0.83 A	208 V	1	60 Hz	19.8 A	20 A	DAIKIN RX36NMVJU; DAIKIN OR LG APPROVED EQUAL	1,2

**FAN SCHEDULE**

- NOTES:
- INTERLOCK FAN CONTROL WITH LIGHT SWITCH
  - PROVIDE BACKDRAFT DAMPER ON DISCHARGE OF FAN
  - PROVIDE SOLID STATE SPEED CONTROLLER; CONTROLLER MUST BE ACCESSIBLE FROM FACE OF FAN

MARK	TYPE	FAN			FAN MOTOR			ELECTRIC SERVICE			ACCEPTABLE MANUFACTURERS	NOTES
		AIR FLOW	MIN ESP	MAX SONES	RPM	DRIVE	POWER	VOLTS	PH	FREQ		
EF-1	CABINET EXHAUST FAN	70 CFM	0.25 in-wg	0.6	900	DIRECT	18 W	115 V	1	60 Hz	GREENHECK SP SERIES; COOK APPROVED EQUAL	1,2,3
EF-2	CABINET EXHAUST FAN	70 CFM	0.25 in-wg	0.6	900	DIRECT	18 W	115 V	1	60 Hz	GREENHECK SP SERIES; COOK APPROVED EQUAL	1,2,3
EF-3	CABINET EXHAUST FAN	210 CFM	0.25 in-wg	0.6	900	DIRECT	50 W	115 V	1	60 Hz	GREENHECK SP SERIES; COOK APPROVED EQUAL	1,2,3
EF-4	CABINET EXHAUST FAN	200 CFM	0.25 in-wg	0.6	900	DIRECT	50 W	115 V	1	60 Hz	GREENHECK SP SERIES; COOK APPROVED EQUAL	1,2,3
EF-5	CABINET EXHAUST FAN	70 CFM	0.25 in-wg	0.6	900	DIRECT	18 W	115 V	1	60 Hz	GREENHECK SP SERIES; COOK APPROVED EQUAL	1,2,3
EF-6	CABINET EXHAUST FAN	70 CFM	0.25 in-wg	0.6	900	DIRECT	18 W	115 V	1	60 Hz	GREENHECK SP SERIES; COOK APPROVED EQUAL	1,2,3
EF-7	CABINET EXHAUST FAN	70 CFM	0.25 in-wg	0.6	900	DIRECT	18 W	115 V	1	60 Hz	GREENHECK SP SERIES; COOK APPROVED EQUAL	1,2,3
EF-8	CABINET EXHAUST FAN	70 CFM	0.25 in-wg	0.6	900	DIRECT	18 W	115 V	1	60 Hz	GREENHECK SP SERIES; COOK APPROVED EQUAL	1,2,3

**INLET AND OUTLET SCHEDULE**

- NOTES:
- CONTRACTOR SHALL COORDINATE LOCATION OF DIFFUSER/GRILLE WITH ARCHITECTURAL REFLECTIVE CEILING PLAN TO AVOID ANY CONFLICTS WITH LIGHTS, AUDIO EQUIPMENT, AND OTHER CEILING APPURTENANCE
  - COORDINATE COLOR OF DIFFUSER/GRILLE WITH ARCHITECT PRIOR TO BID/ORDERING
  - DIFFUSER TO BE FURNISHED AND INSTALLED WITH FOIL-BACKED R-6 INSULATION

MARK	DESCRIPTION	CFM RANGE		FACE SIZE	NECK		CONSTRUCTION MATERIAL	ACCEPTABLE MANUFACTURERS	NOTES
		MIN.	MAX.		TYPE	SIZE			
A	SQUARE 4 CONE FIXED PATTERN CEILING DIFFUSER	0 CFM	130 CFM	24 X 24	ROUND	6	ALUMINUM	TITUS TDC; PRICE OR NAILOR APPROVED EQUAL	1,2,3
B	DOUBLE DEFLECTION SIDEWALL GRILLE W/ 3/4" BLADE SPACING	0 CFM	540 CFM	12 X 12	RECT	12 X 12	ALUMINUM	PRICE 620 SERIES; NAILOR 5100 SERIES; TITUS 300FS SERIES	
C	SQUARE 4 CONE FIXED PATTERN CEILING DIFFUSER	230 CFM	320 CFM	24 X 24	ROUND	10	ALUMINUM	TITUS TDC; PRICE OR NAILOR APPROVED EQUAL	1,2,3
D	SQUARE 4 CONE FIXED PATTERN CEILING DIFFUSER	320 CFM	600 CFM	24 X 24	ROUND	12	ALUMINUM	TITUS TDC; PRICE OR NAILOR APPROVED EQUAL	1,2,3
E1	1/2" X 1/2" X 1" EGGGRATE	0 CFM	630 CFM	12 X 12	RECT	12 X 12	ALUMINUM	NAILOR MODEL 51EC; PRICE MODEL 81; TITUS 50F	1,2
E2	1/2" X 1/2" X 1" EGGGRATE	0 CFM	310 CFM	8 X 8	RECT	8 X 8	ALUMINUM	NAILOR MODEL 51EC; PRICE MODEL 81; TITUS 50F	1,2
E3	45° DEFLECTION SIDEWALL GRILLE W/ 3/4" BLADE SPACING	0 CFM	370 CFM	12 X 12	RECT	12 X 12	ALUMINUM	PRICE 630 SERIES; NAILOR 5100 SERIES; TITUS 350 SERIES	
E4	45° DEFLECTION SIDEWALL GRILLE W/ 3/4" BLADE SPACING	0 CFM	370 CFM	12 X 8	RECT	12 X 8	ALUMINUM	PRICE 630 SERIES; NAILOR 5100 SERIES; TITUS 350 SERIES	1,2

ARCHITECT

DOMAIN ARCHITECTURE  
 8316 Kellwood Avenue, Baton Rouge, LA 70806  
 t: 225.216.3770 f: 225.216.3771  
 www.domain-arch.com

REGISTRATION

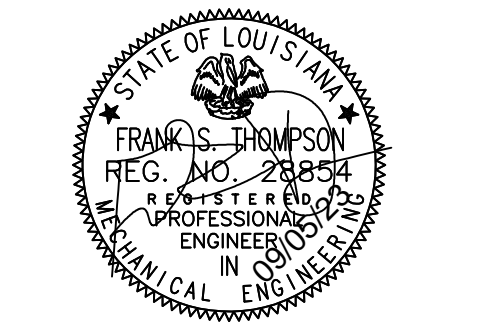

These drawings are the property of DOMAIN ARCHITECTURE APAC and are not to be reproduced in whole or in part. They are only to be used for the project and site specifically identified herein. Scales stated herein are valid on the original drawings only. Contractor shall carefully review all dimensions and conditions shown and report to the architect any errors, inconsistencies, or omissions discovered. These plans were prepared in the office under our personal supervision, and to the best of our knowledge comply with state and local codes. We will generally administer construction.

CLIENT

Southern University Laboratory School  
**BATHROOM RENOVATIONS**

PROJECT INFORMATION

revisions	No.	Description	Date

project # C22-0072

date September 5, 2023

director review

MECHANICAL SCHEDULES

M9.20

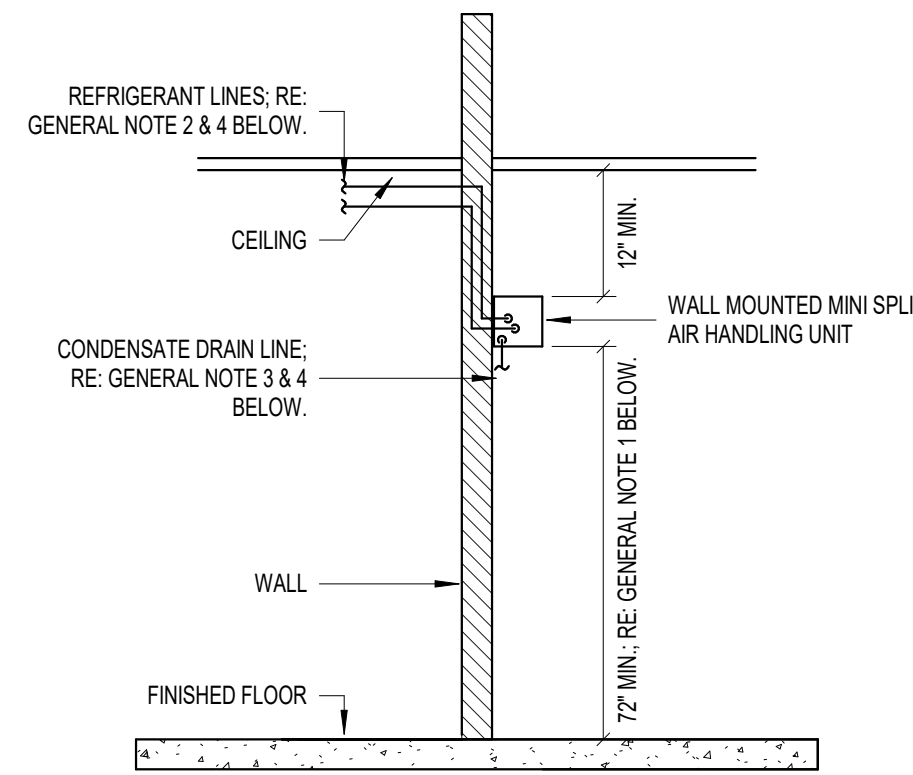

**GENERAL NOTES:**

- COORDINATE MOUNTING HEIGHT OF AIR HANDLING UNIT WITH ROOM DIMENSIONS, CEILING/STRUCTURE HEIGHT, AND ANY OBSTRUCTIONS LOCATED ON WALL. AIR HANDLING UNIT TO BE FURNISHED AND INSTALLED WITH ALL NECESSARY HARDWARE FOR PROPER MOUNTING FROM FACTORY (I.E. BRACKETS, FASTENERS, WASHERS, ETC.) RE: MANUFACTURER'S RECOMMENDATIONS AND REQUIREMENTS FOR MOUNTING OF UNIT.
- ALL REFRIGERANT LINES SHALL BE SIZED IN STRICT ACCORDANCE WITH MANUFACTURER'S RECOMMENDATIONS. REFRIGERANT LINES SHALL BE ROUTED THROUGH WALL AND EXPOSED THROUGH ATTIC OR CEILING SPACE TO RESPECTIVE CONDENSING UNIT LOCATED AT EXTERIOR. SEAL EXTERIOR WALL/ROOF PENETRATION WATER TIGHT.
- CONDENSATE DRAIN LINE SHALL BE INSTALLED WITH "P-TRAP" AND INSULATED. CONDENSATE DRAIN LINE SHALL BE ROUTED WITH DISCHARGE TO NEAREST HUB DRAIN AND MUST MAINTAIN MINIMUM 2" AIR GAP BETWEEN DRAIN TERMINATION AND HUB DRAIN RIM.
- ALL REFRIGERANT AND CONDENSATE DRAIN LINES SHALL BE ROUTED IN SUCH A MANNER AS TO NOT BLOCK OR OBSTRUCT ANY ACCESS (FILTER, COOLING COIL, FAN, ECT.) TO AIR HANDLING UNIT.

**1** DETAIL - WALL MOUNTED MINI SPLIT AIR HANDLING UNIT  
NOT TO SCALE

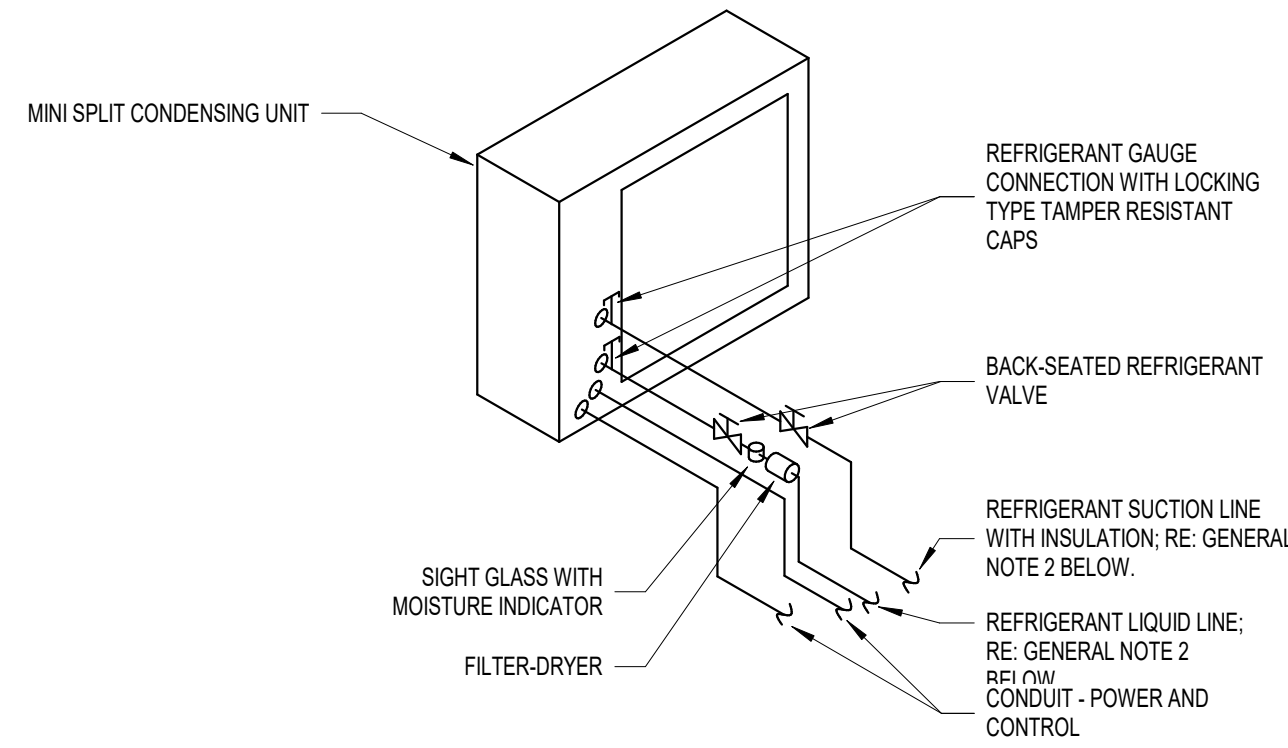

**GENERAL NOTES:**

- ALL REFRIGERANT LINES SHALL BE SIZED IN STRICT ACCORDANCE WITH MANUFACTURER'S RECOMMENDATIONS. REFRIGERANT LINES SHALL BE ROUTED THROUGH EXTERIOR WALL AND ALONG WALL TO RESPECTIVE AIR HANDLING UNIT. SEAL WALL PENETRATION WATER TIGHT.

**2** DETAIL - AIR COOLED DX CONDENSING UNIT  
NOT TO SCALE

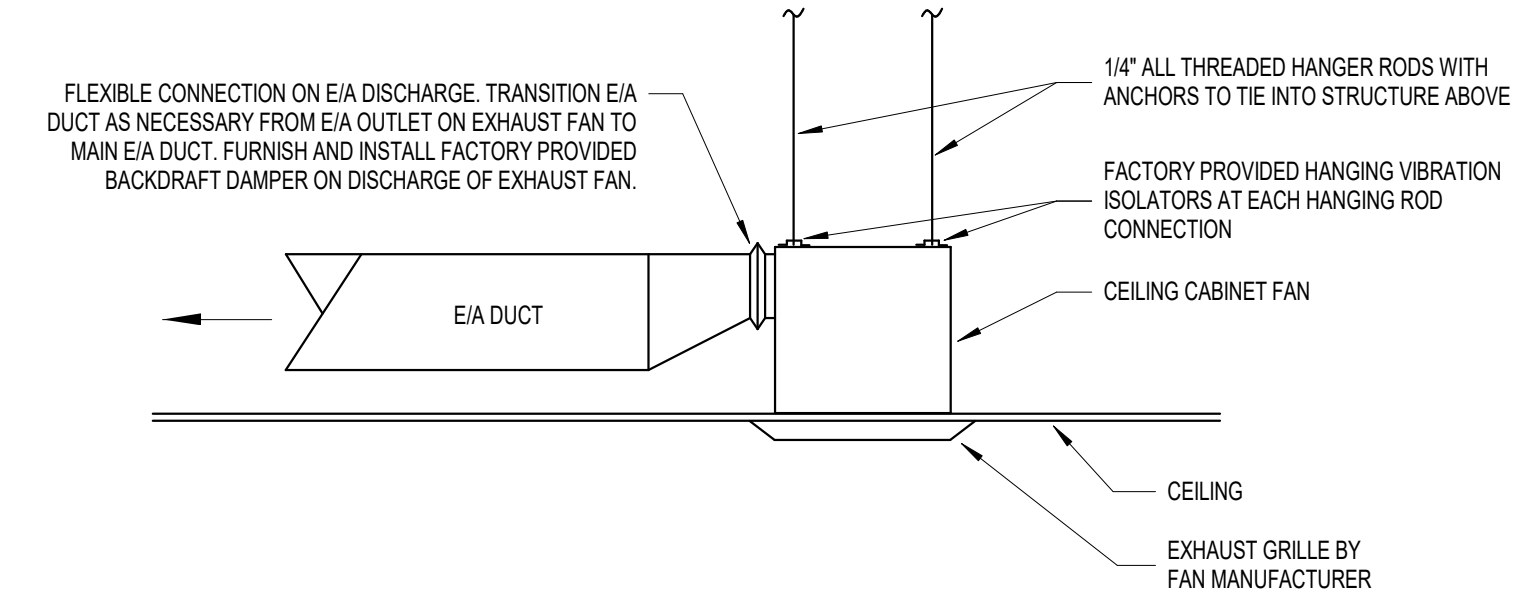

**GENERAL NOTES:**

- CEILING CABINET FAN SHALL BE FACTORY PROVIDED WITH AN INSULATED FAN HOUSING.
- PROVIDE SUPPORT ON EXHAUST DUCT AS PER SMACNA STANDARDS AND WITH A MINIMUM OF (2) SUPPORTS ON DUCTS OVER 6'-0" IN LENGTH AND (1) SUPPORT ON DUCTS UNDER 6'-0" IN LENGTH.
- REFER TO MECHANICAL FLOOR PLANS FOR EXHAUST AIR DISCHARGE TERMINATION TYPE (THROUGH EXTERIOR WALL OR ROOF).

**3** DETAIL - CEILING CABINET EXHAUST FAN  
NOT TO SCALE

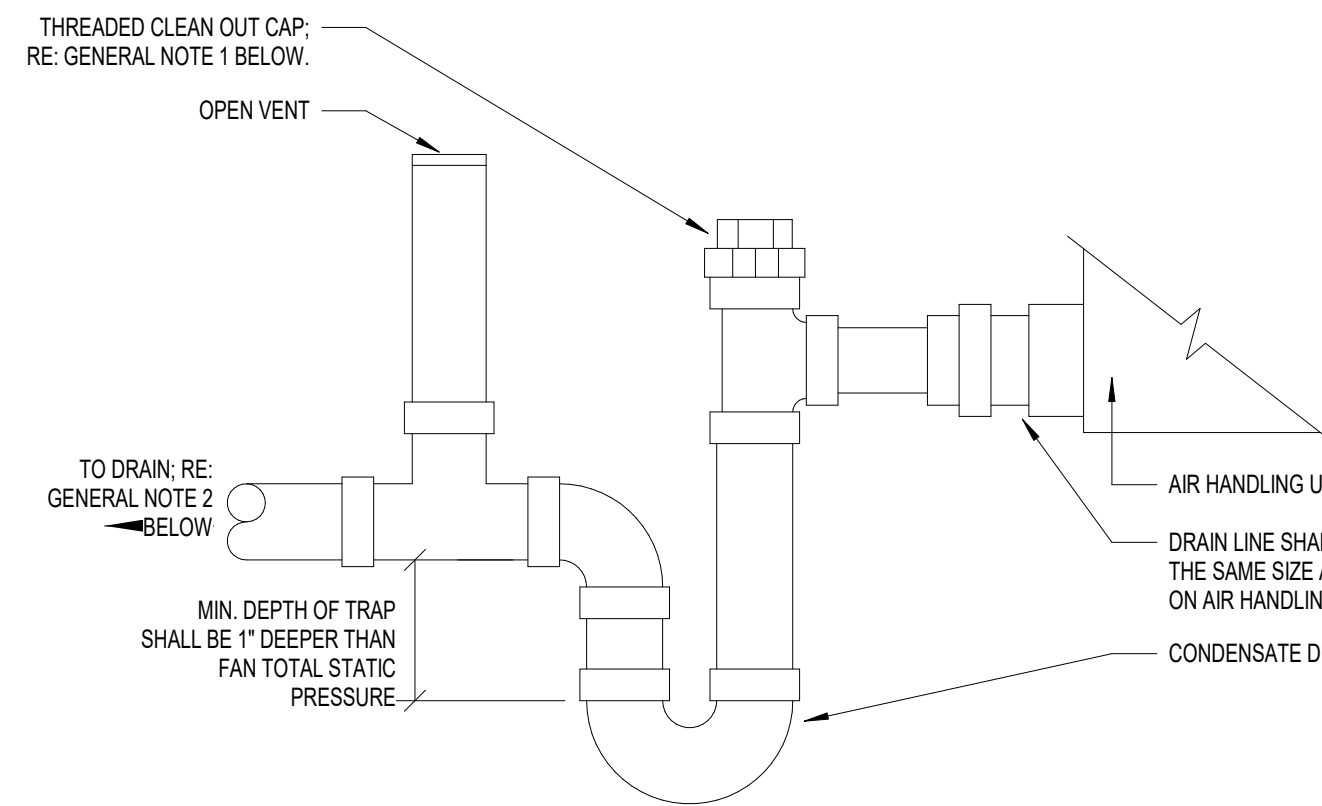

**GENERAL NOTES:**

- INSTALL A CLEANOUT AT EVERY CHANGE IN DIRECTION GREATER THAN 45° AND AT A MAXIMUM OF 25' INTERVALS.
- PITCH CONDENSATE DRAIN DOWN TOWARD DRAIN AT A MINIMUM OF 1/8" PER FOOT.

**4** DETAIL - CONDENSATE DRAIN TRAP  
NOT TO SCALE

HANGER SIZES FOR RECTANGULAR DUCT			
MAX. SIZE	HANGER	HORIZONTAL SUPPORT ANGLE	MAX. SPACING
30"	1"x18 GAGE STRAP	NONE REQUIRED	10'-0"
36"	1/4" ROUND ROD	1.5"x1.5"x1/8"	8'-0"
48"	1/4" ROUND ROD	2"x2"x1/8"	8'-0"
60"	5/16" ROUND ROD	2"x2"x1/8"	8'-0"
84"	3/8" ROUND ROD	2"x2"x1/8"	8'-0"

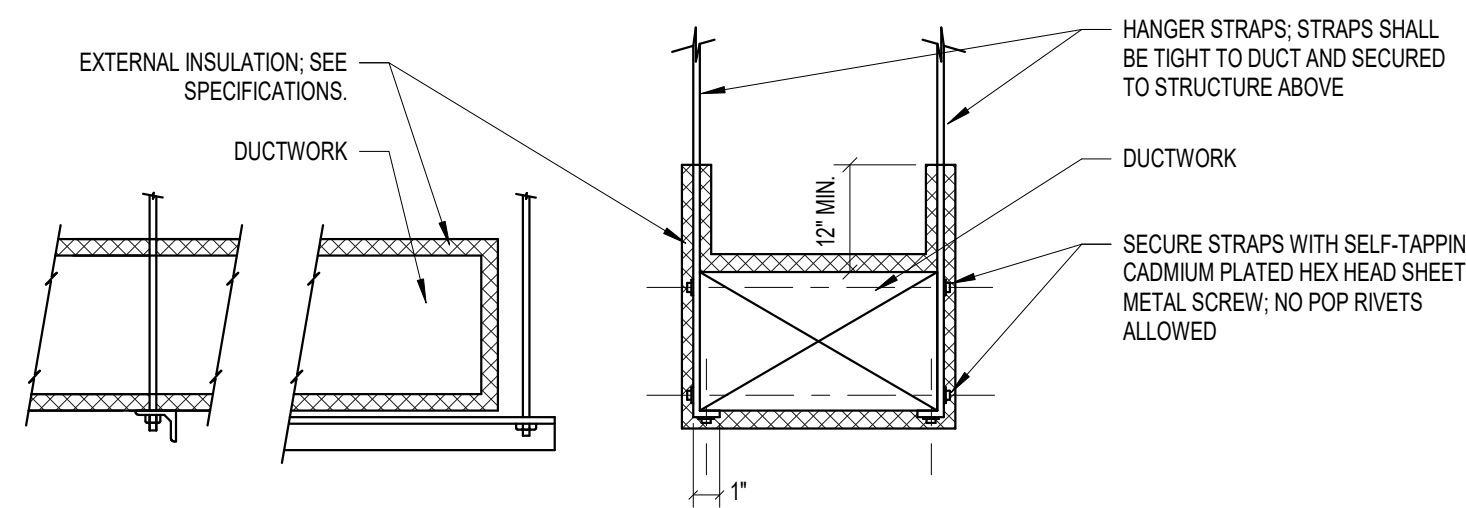

**5** DETAIL - DUCT SUPPORT HANGERS  
NOT TO SCALE

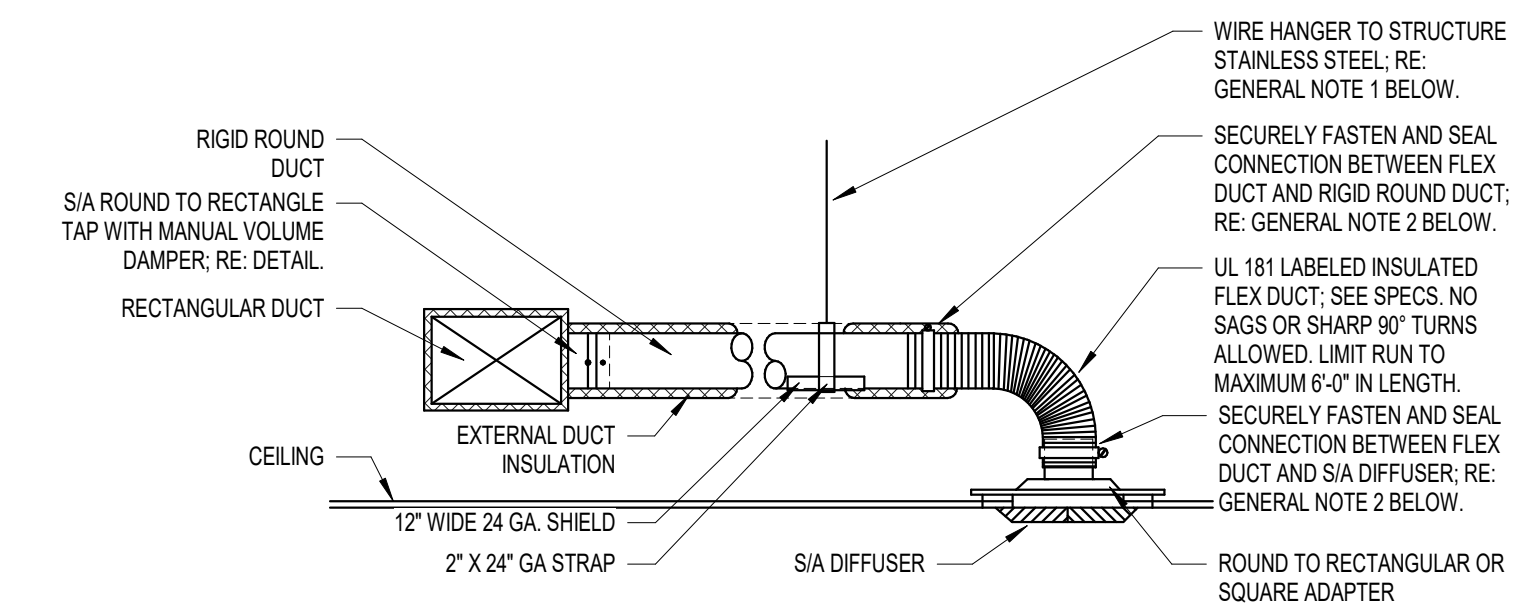

**GENERAL NOTES:**

- PROVIDE SUPPORT ON ALL BRANCH DUCT RUNOUTS AS PER SMACNA STANDARDS AND WITH A MINIMUM OF (2) SUPPORTS ON BRANCH DUCTS OVER 6'-0" IN LENGTH AND (1) SUPPORT ON BRANCH DUCTS UNDER 6'-0" IN LENGTH.
- CONNECTION TO BE MADE WITH PRESSURE SENSITIVE TAPE, AS PER SECTION 803.9 OF IMC, AS WELL AS A STAINLESS STEEL SCREW DRIVER OPERATED BAND. ALL FLEX DUCT CONNECTIONS SHALL ADHERE TO SECTION 603.9 OF 2009 IMC AND MANUFACTURER'S INSTALLATION INSTRUCTIONS.

**6** DETAIL - TYPICAL DIFFUSER CONNECTION  
NOT TO SCALE

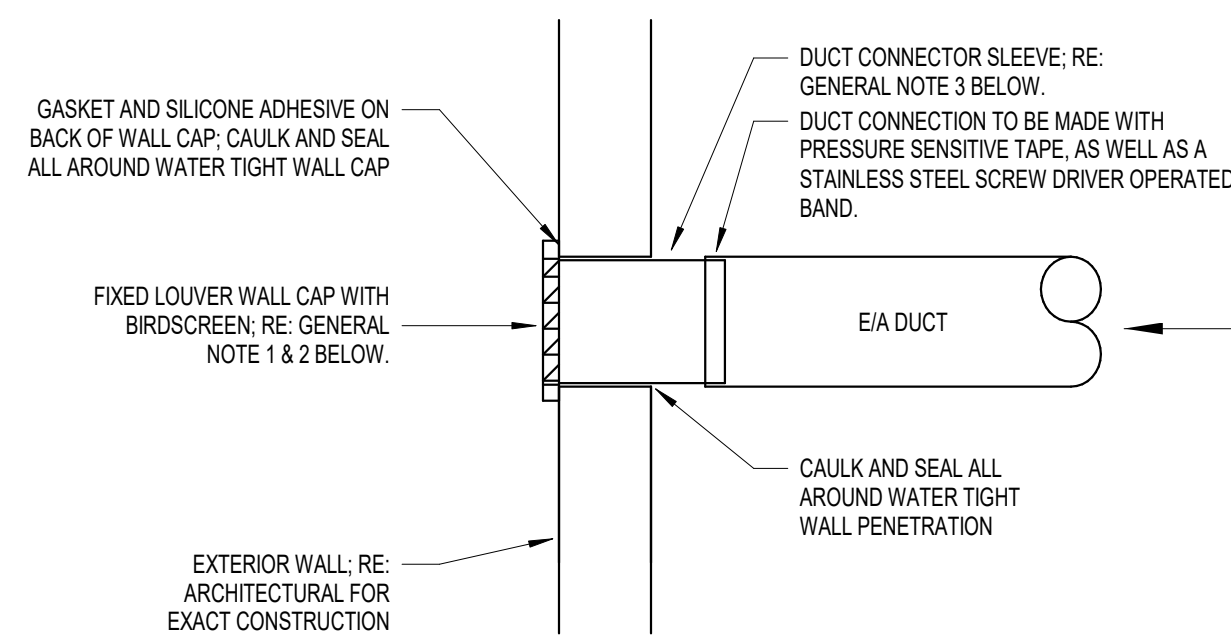

**GENERAL NOTES:**

- REFER TO MANUFACTURER'S INSTALLATION GUIDE AND RECOMMENDATIONS FOR EXACT MOUNTING REQUIREMENTS OF WALL CAP IN EXTERIOR WALL.
- ALL EXHAUST AIR OUTLETS AND AIR INTAKES SHALL BE LOCATED A MINIMUM OF 10'-0" APART, UNLESS OTHERWISE NOTED ON PLANS.
- WALL CAP/CONNECTOR SLEEVE TO BE SAME SIZE AS CONNECTED DUCT SIZE SHOWN ON PLANS.

**7** DETAIL - E/A DISCHARGE WALL CAP  
NOT TO SCALE

ARCHITECT

**DOMAIN**  
ARCHITECTURE

8316 kelwood avenue  
baton rouge, la 70806  
t: 225.216.3770 f: 225.216.3771  
www.domain-dsgn.com

REGISTRATION

STATE OF LOUISIANA  
FRANCIS THOMPSON  
REG. NO. 28854  
PROFESSIONAL ENGINEER  
MECHANICAL ENGINEER

These drawings are the property of DOMAIN ARCHITECTURE APC and are not to be reproduced in whole or in part. They are only to be used for the project and site specifically identified herein. Scales stated herein are valid on the original drawing only. Contractor shall carefully review all dimensions and conditions shown and report to the architect any errors, inconsistencies, or omissions discovered. These plans were prepared in this office under our personal supervision, and to the best of our knowledge comply with state and local codes. We will generally administer construction.

CLIENT

Southern University Laboratory School  
**BATHROOM RENOVATIONS**

129 SWAN AVE,  
BATON ROUGE, LA 70813

PROJECT INFORMATION

revisions No.	Description	Date

project # **C22-0072**  
date **September 5, 2023**  
director review

MECHANICAL DETAILS

**M9.30**

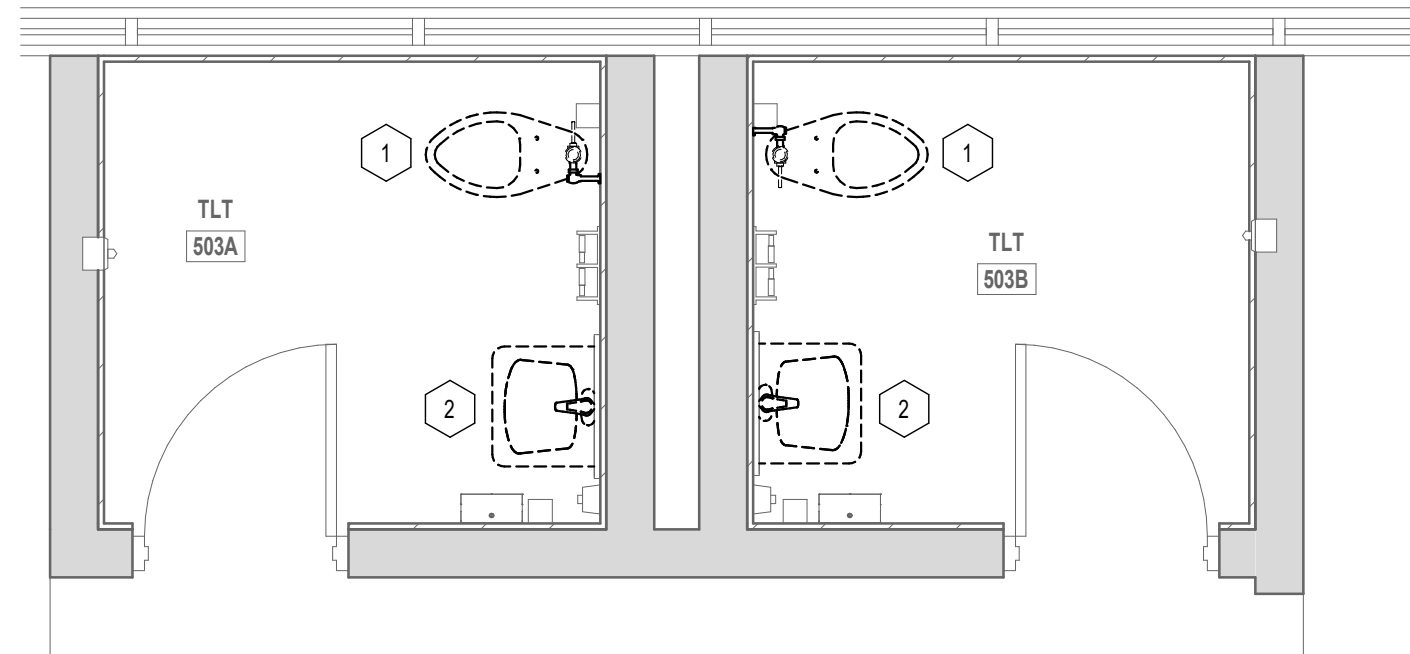

**1** KINDERGARTEN - PLUMBING DEMOLITION FLOOR PLAN  
3/8" = 1'-0"

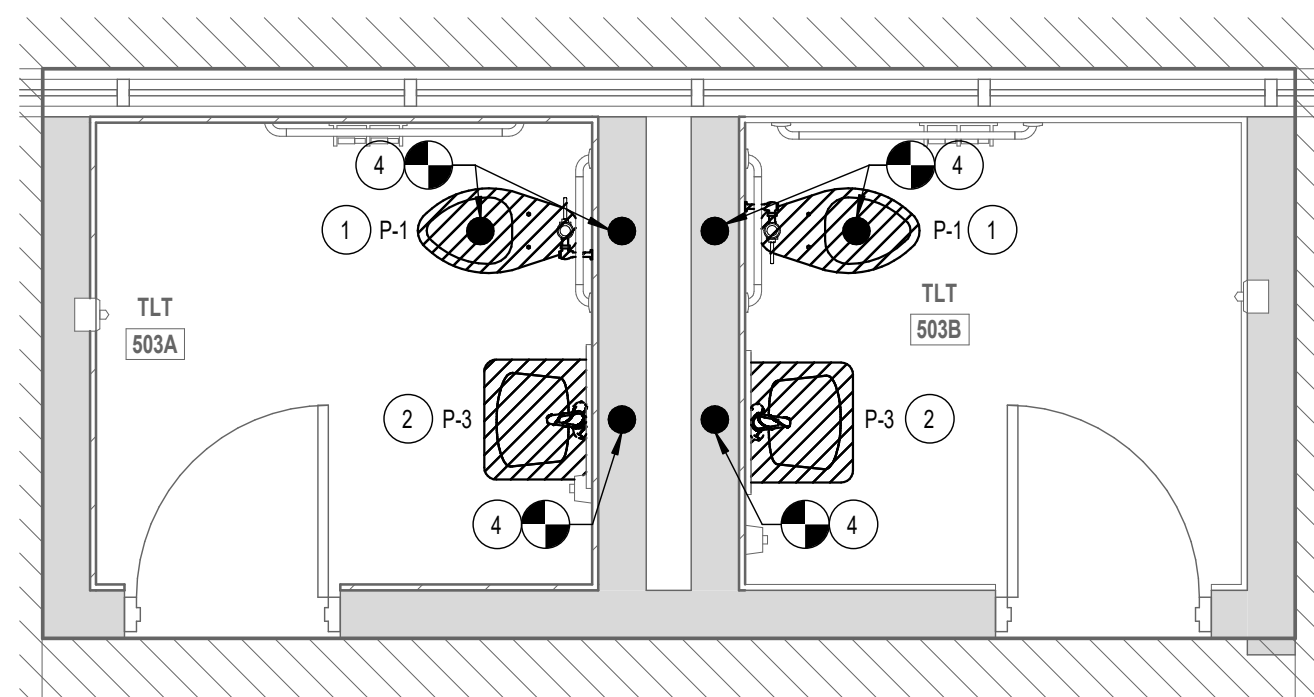

**2** KINDERGARTEN - PLUMBING FLOOR PLAN  
3/8" = 1'-0"

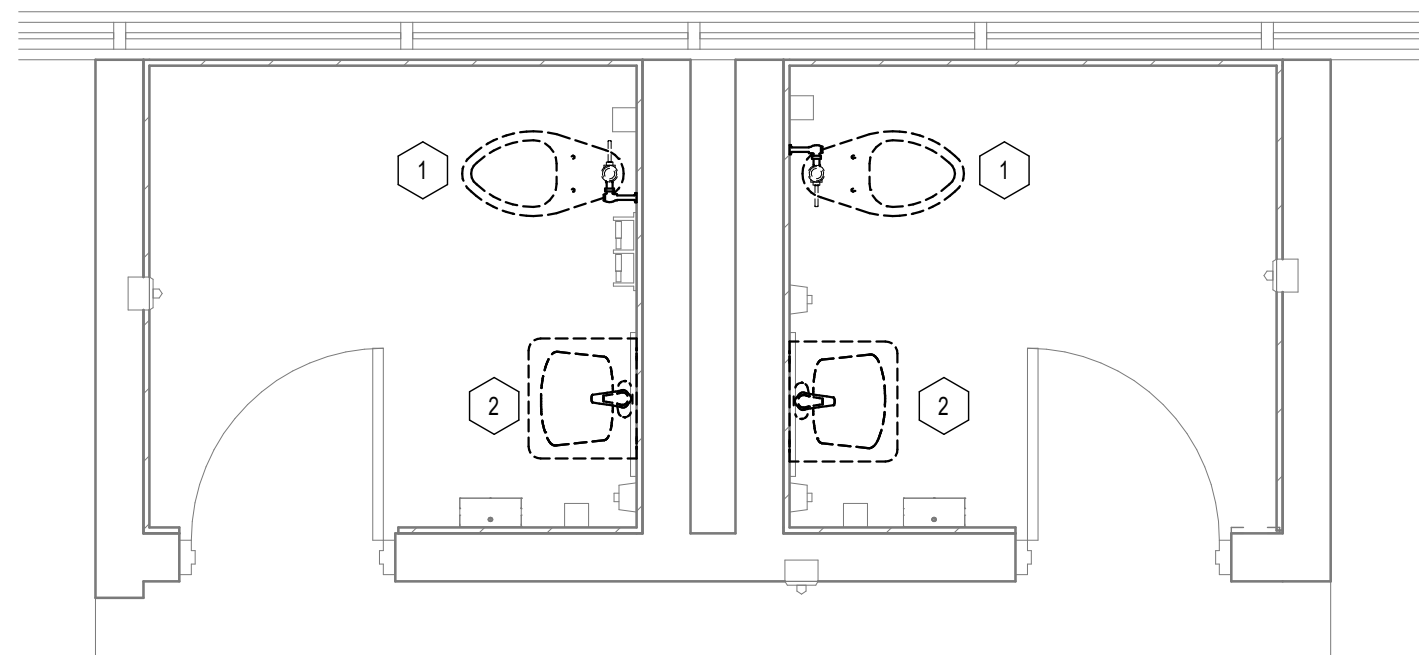

**3** KINDERGARTEN - PLUMBING DEMOLITION FLOOR PLAN  
3/8" = 1'-0"

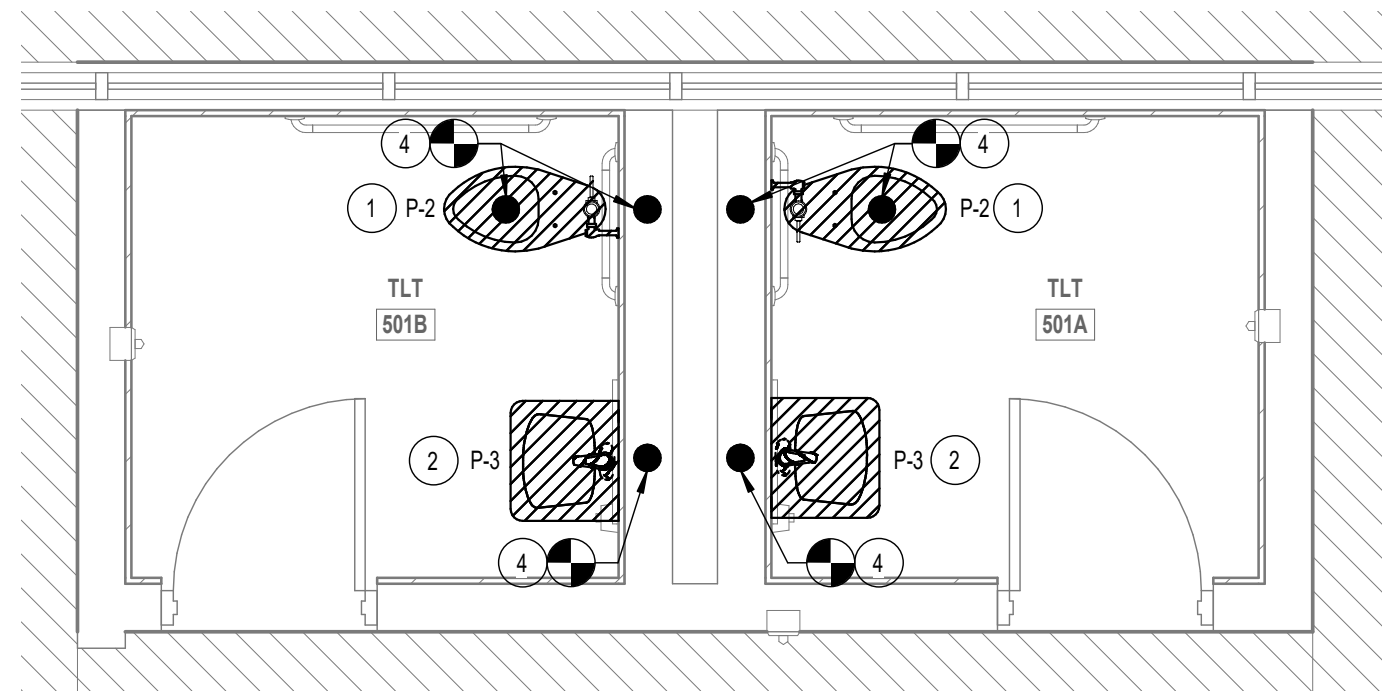

**4** KINDERGARTEN - PLUMBING FLOOR PLAN  
3/8" = 1'-0"

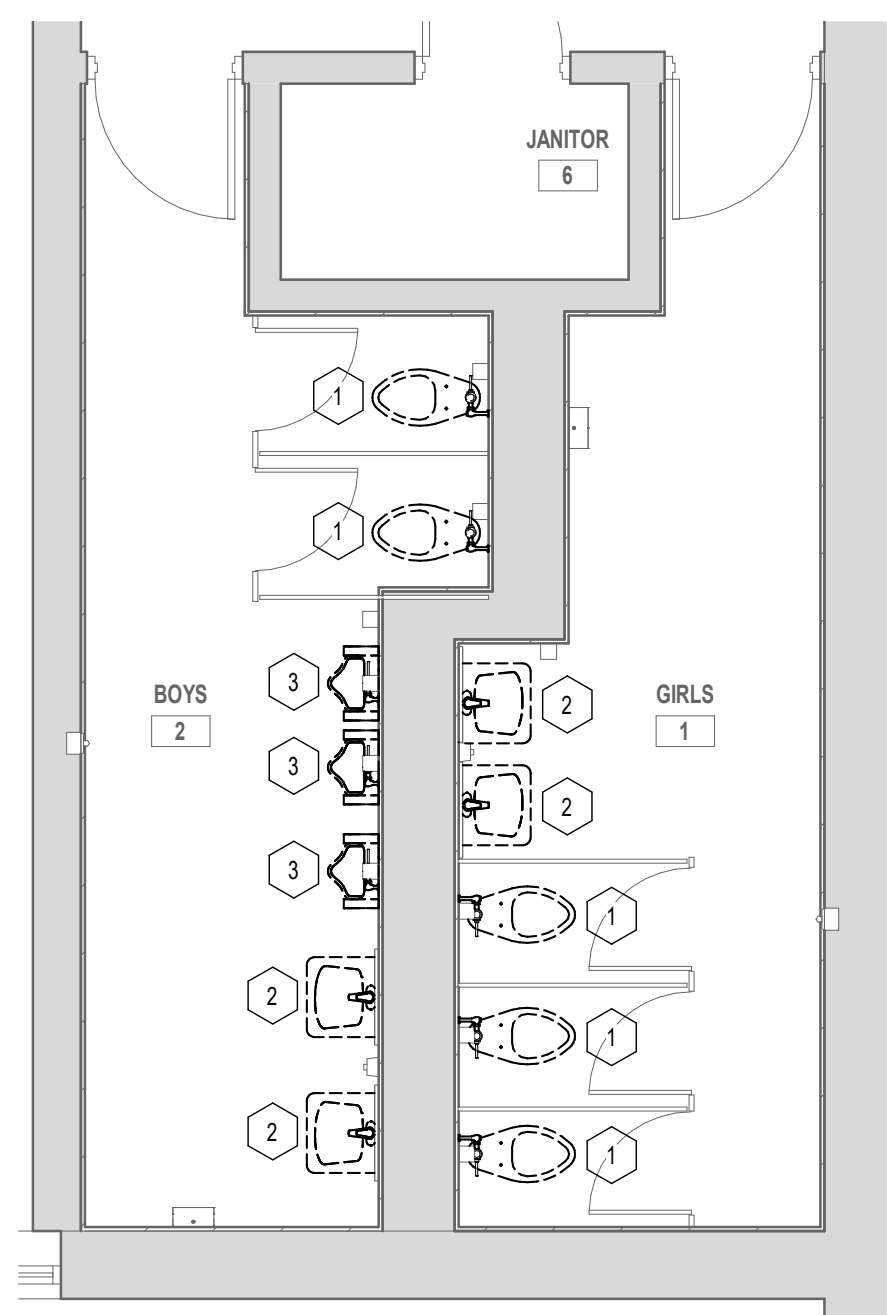

**5** 1ST FLOOR EXTERIOR BATHROOMS - PLUMBING DEMOLITION FLOOR PLAN  
1/4" = 1'-0"

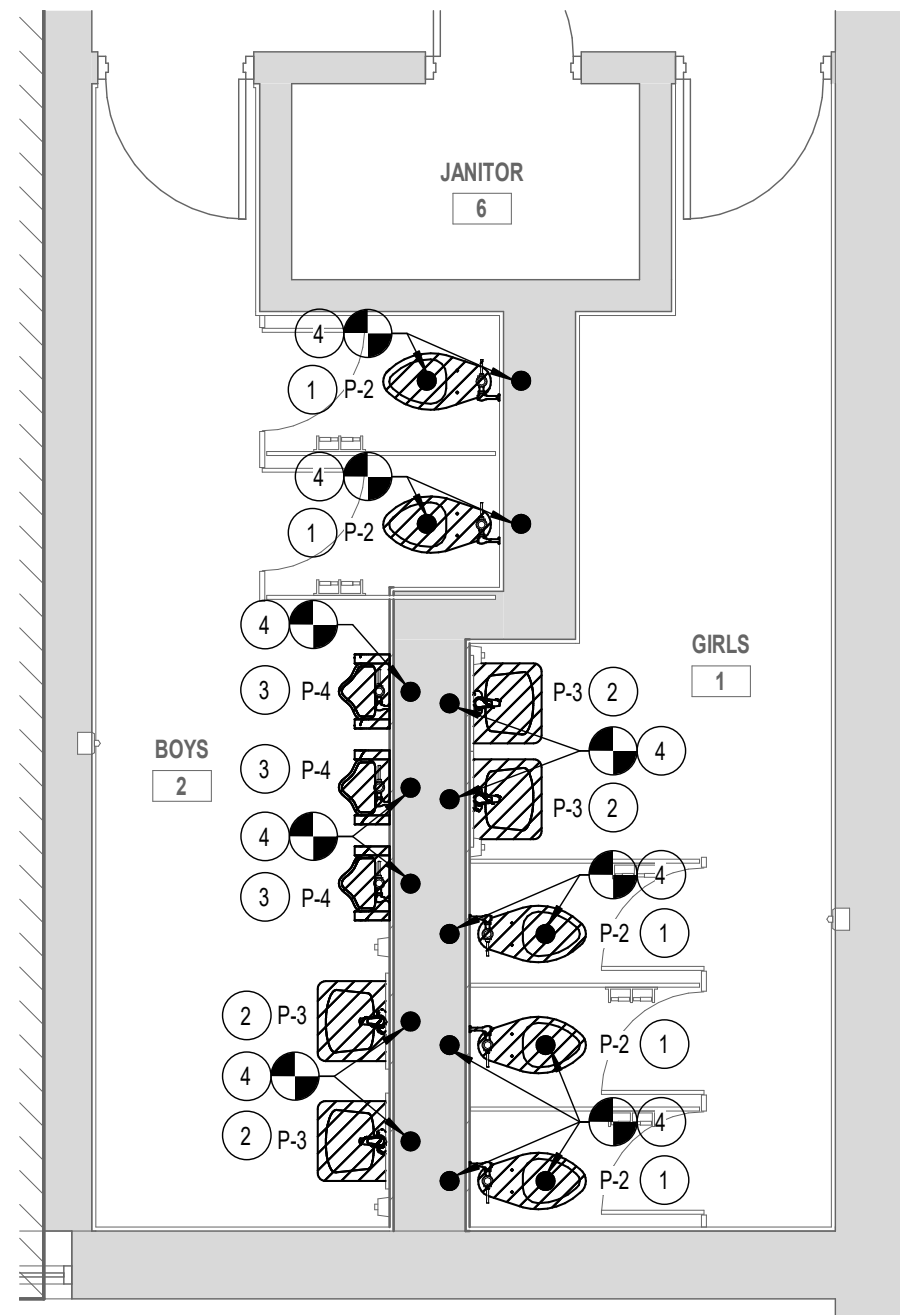

**6** 1ST FLOOR EXTERIOR BATHROOMS - PLUMBING FLOOR PLAN  
1/4" = 1'-0"

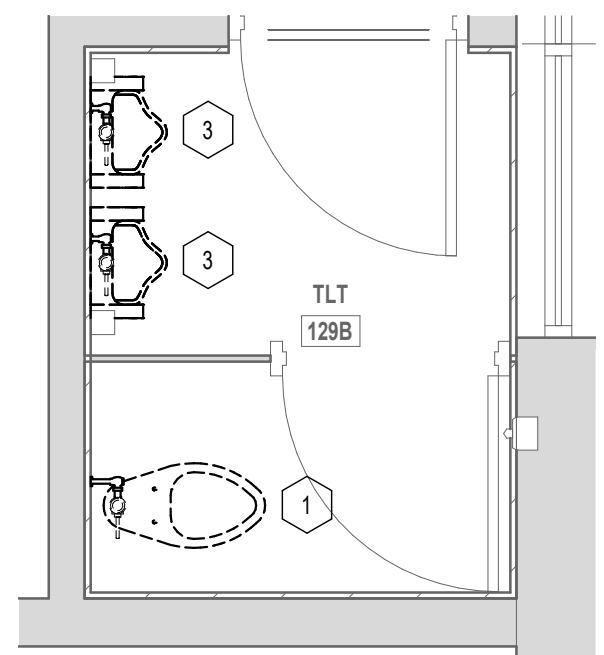

**7** ART CLASSROOM - PLUMBING DEMOLITION FLOOR PLAN  
3/8" = 1'-0"

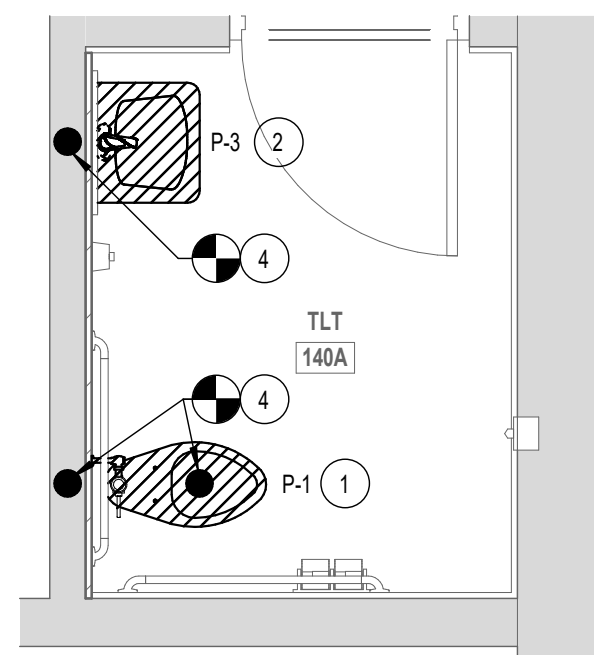

**8** ART CLASSROOM - PLUMBING FLOOR PLAN  
3/8" = 1'-0"

**PLUMBING DEMO NOTES**

- 1 CONTRACTOR TO REMOVE EXISTING WATER CLOSET IN BOLD DASHED LINES. TEMPORARILY CAP EXISTING SANITARY SEWER IN FLOOR AND DOMESTIC WATER IN WALL. PREPARE FOR INSTALLATION OF NEW. RE. PLUMBING FOR PLAN THIS SHEET.
- 2 CONTRACTOR TO REMOVE EXISTING LAVATORY IN BOLD DASHED LINES. TEMPORARILY CAP EXISTING SANITARY SEWER AND DOMESTIC WATER IN WALL. PREPARE FOR INSTALLATION OF NEW. RE. PLUMBING FLOOR PLAN THIS SHEET.
- 3 CONTRACTOR TO REMOVE EXISTING URINAL IN BOLD DASHED LINES. TEMPORARILY CAP EXISTING SANITARY SEWER AND DOMESTIC WATER IN WALL. PREPARE FOR INSTALLATION OF NEW. RE. PLUMBING FLOOR PLAN THIS SHEET.

**PLUMBING PLAN NOTES**

- 1 4"W., 3/4", 1" CW., TO SERVE WATER CLOSET, TYPICAL.
- 2 2"W., 2/4", 1/2" H&CW., TO SERVE LAVATORY, TYPICAL.
- 3 2"W., 2/4", 3/4" CW., TO SERVE URINAL, TYPICAL.
- 4 CONTRACTOR TO CONNECT TO EXISTING SANITARY SEWER AND DOMESTIC WATER SERVICE IN APPROXIMATE LOCATION SHOWN. VERIFY EXACT SIZE, LOCATION, AND DIRECTION OF FLOW OF EXISTING ON JOB SITE AND CONNECT TO EXISTING SERVICES OF SUFFICIENT SIZE. CONTRACTOR SHALL SAWCUT AS REQUIRED.

ARCHITECT

**DOMAIN**  
 ARCHITECTURE  
 8316 Kellwood Avenue, Baton Rouge, LA 70806  
 t: 225.216.3770 f: 225.216.3771  
 www.domain-dsgn.com

REGISTRATION

These drawings are the property of DOMAIN ARCHITECTURE APC and are not to be reproduced in whole or in part. They are only to be used for the project and site specifically identified herein. Scales stated herein are valid on the original drawing only. Contractor shall carefully review all dimensions and conditions shown and report to the architect any errors, inconsistencies, or omissions discovered. These plans were prepared in the office under our personal supervision, and to the best of our knowledge comply with state and local codes. We will generally administer construction.

CLIENT

Southern University Laboratory School  
**BATHROOM RENOVATIONS**

PROJECT INFORMATION

revisions	No.	Description	Date

project # **C22-0072**  
 date **September 5, 2023**  
 director review

ENLARGED PLUMBING PLANS

**P9.01**

129 SWAN AVE,  
 BATON ROUGE, LA 70813

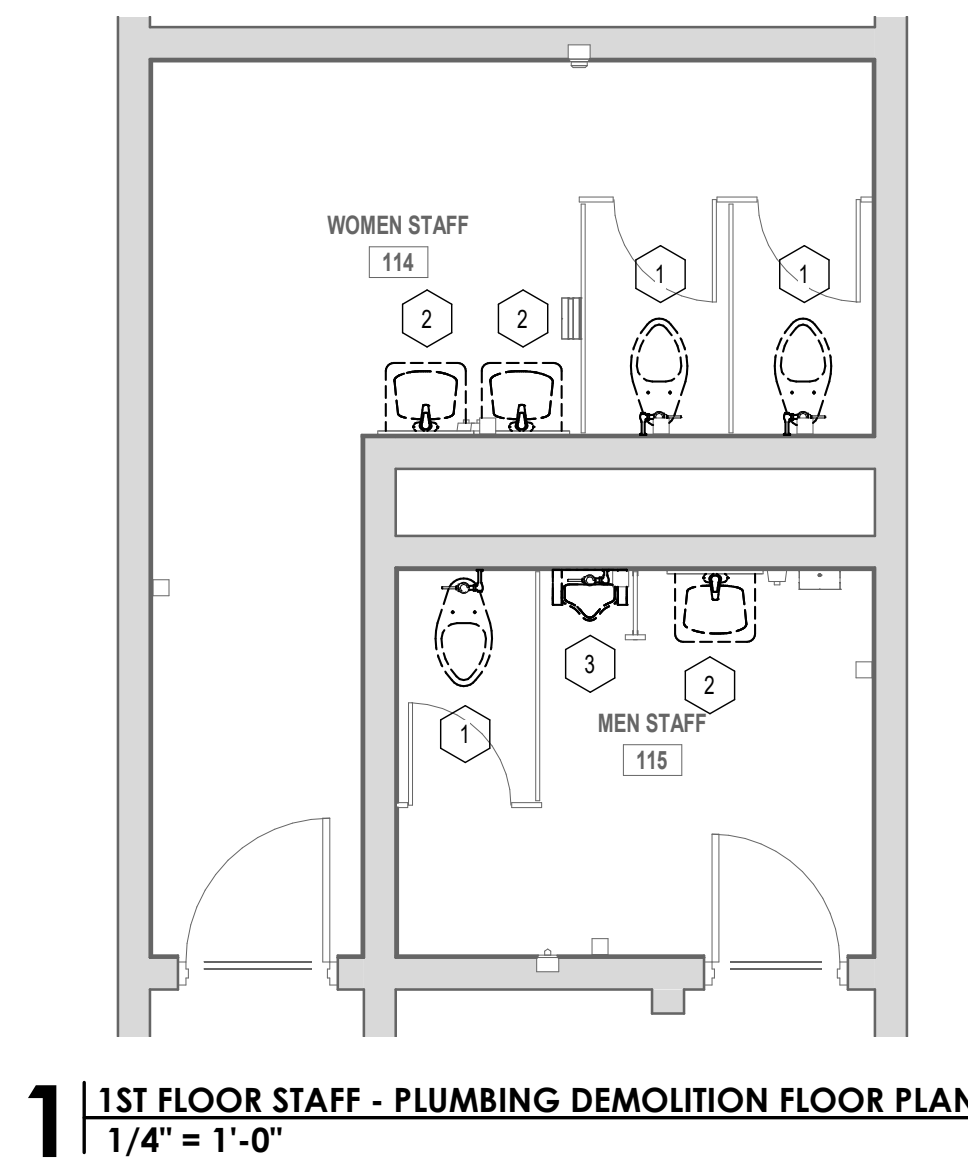

**1** 1ST FLOOR STAFF - PLUMBING DEMOLITION FLOOR PLAN  
1/4" = 1'-0"

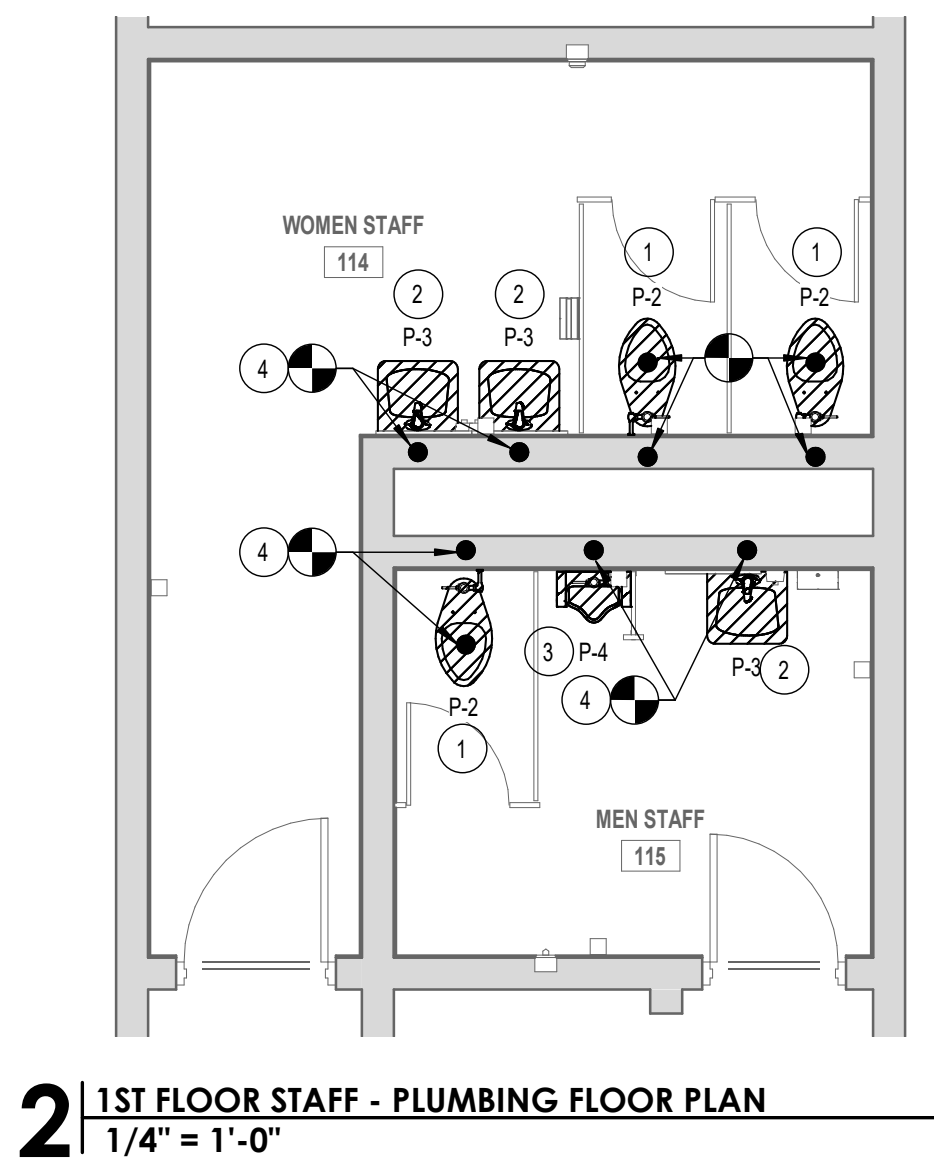

**2** 1ST FLOOR STAFF - PLUMBING FLOOR PLAN  
1/4" = 1'-0"

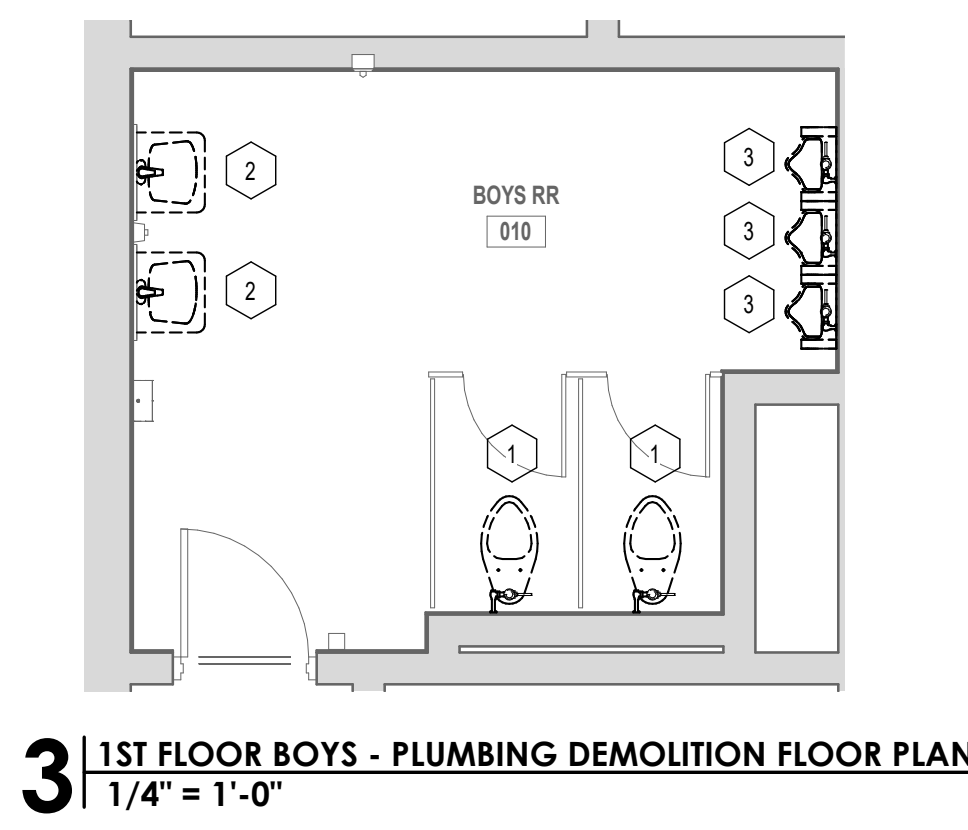

**3** 1ST FLOOR BOYS - PLUMBING DEMOLITION FLOOR PLAN  
1/4" = 1'-0"

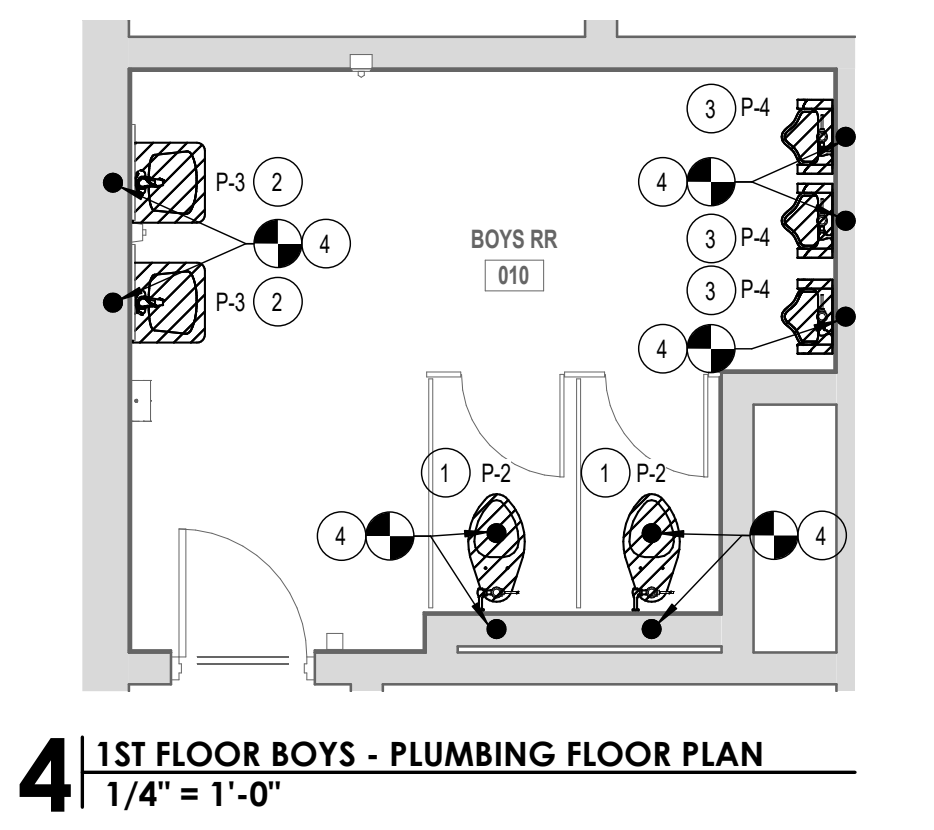

**4** 1ST FLOOR BOYS - PLUMBING FLOOR PLAN  
1/4" = 1'-0"

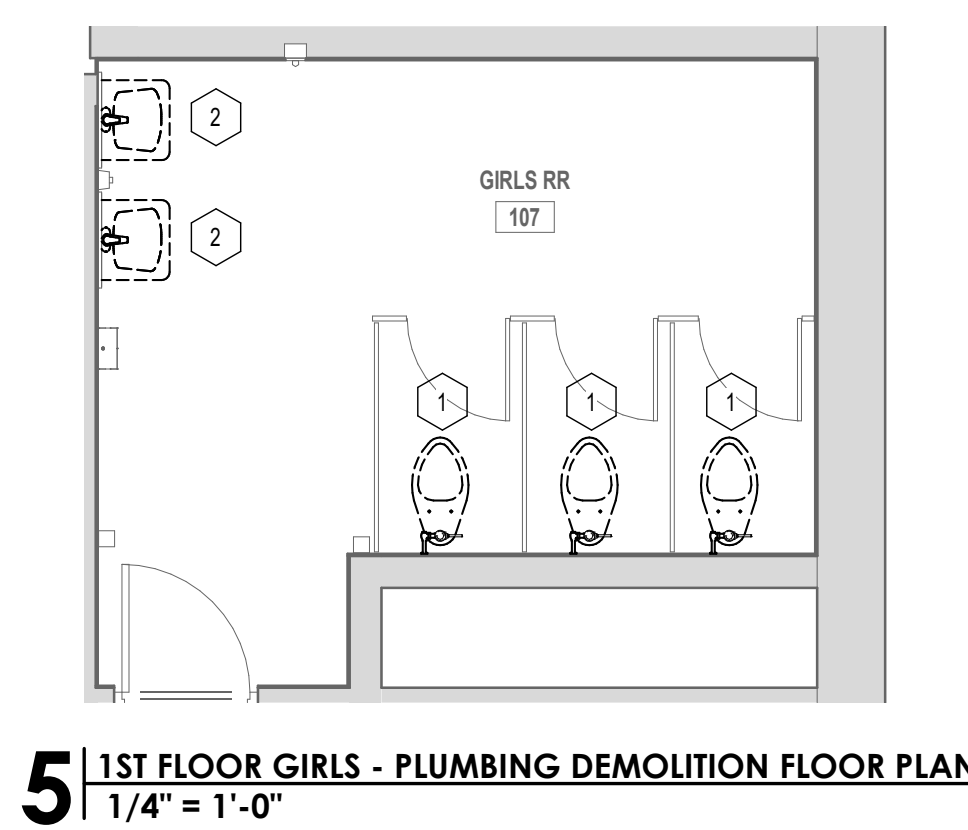

**5** 1ST FLOOR GIRLS - PLUMBING DEMOLITION FLOOR PLAN  
1/4" = 1'-0"

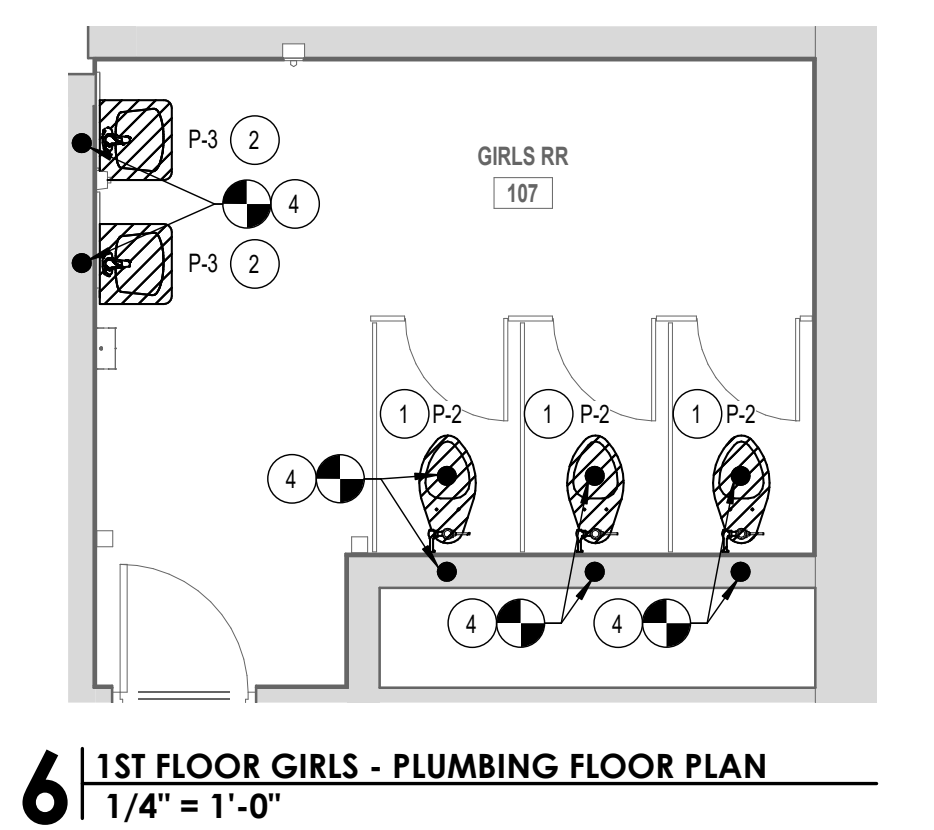

**6** 1ST FLOOR GIRLS - PLUMBING FLOOR PLAN  
1/4" = 1'-0"

**PLUMBING DEMO NOTES**

- 1 CONTRACTOR TO REMOVE EXISTING WATER CLOSET IN BOLD DASHED LINES. TEMPORARILY CAP EXISTING SANITARY SEWER IN FLOOR AND DOMESTIC WATER IN WALL. PREPARE FOR INSTALLATION OF NEW. RE. PLUMBING FOR PLAN THIS SHEET.
- 2 CONTRACTOR TO REMOVE EXISTING LAVATORY IN BOLD DASHED LINES. TEMPORARILY CAP EXISTING SANITARY SEWER AND DOMESTIC WATER IN WALL. PREPARE FOR INSTALLATION OF NEW. RE. PLUMBING FLOOR PLAN THIS SHEET.
- 3 CONTRACTOR TO REMOVE EXISTING URINAL IN BOLD DASHED LINES. TEMPORARILY CAP EXISTING SANITARY SEWER AND DOMESTIC WATER IN WALL. PREPARE FOR INSTALLATION OF NEW. RE. PLUMBING FLOOR PLAN THIS SHEET.

**PLUMBING PLAN NOTES**

- 1 4"W., 3"V., 1" CW., TO SERVE WATER CLOSET, TYPICAL.
- 2 2"W., 2"V., 1/2" H&CW., TO SERVE LAVATORY, TYPICAL.
- 3 2"W., 2"V., 3/4" CW., TO SERVE URINAL, TYPICAL.
- 4 CONTRACTOR TO CONNECT TO EXISTING SANITARY SEWER AND DOMESTIC WATER SERVICE IN APPROXIMATE LOCATION SHOWN. VERIFY EXACT SIZE, LOCATION, AND DIRECTION OF FLOW OF EXISTING ON JOB SITE AND CONNECT TO EXISTING SERVICES OF SUFFICIENT SIZE. CONTRACTOR SHALL SAWCUT AS REQUIRED.

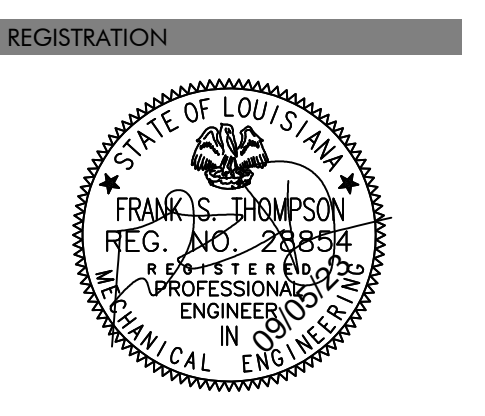

These drawings are the property of DOMAIN ARCHITECTURE APC and are not to be reproduced in whole or in part. They are only to be used for the project and site specifically identified herein. Scales stated herein are valid on the original drawings only. Contractor shall carefully review all dimensions and conditions shown and report to the architect any errors, inconsistencies, or omissions discovered. These plans were prepared in this office under our personal supervision, and to the best of our knowledge comply with state and local codes. We will generally administer construction.

CLIENT

Southern University Laboratory School  
**BATHROOM RENOVATIONS**

129 SWAN AVE,  
BATON ROUGE, LA 70813

PROJECT INFORMATION

revisions	No.	Description	Date

project # C22-0072

date September 5, 2023

director review

ENLARGED PLUMBING PLANS

**P9.02**

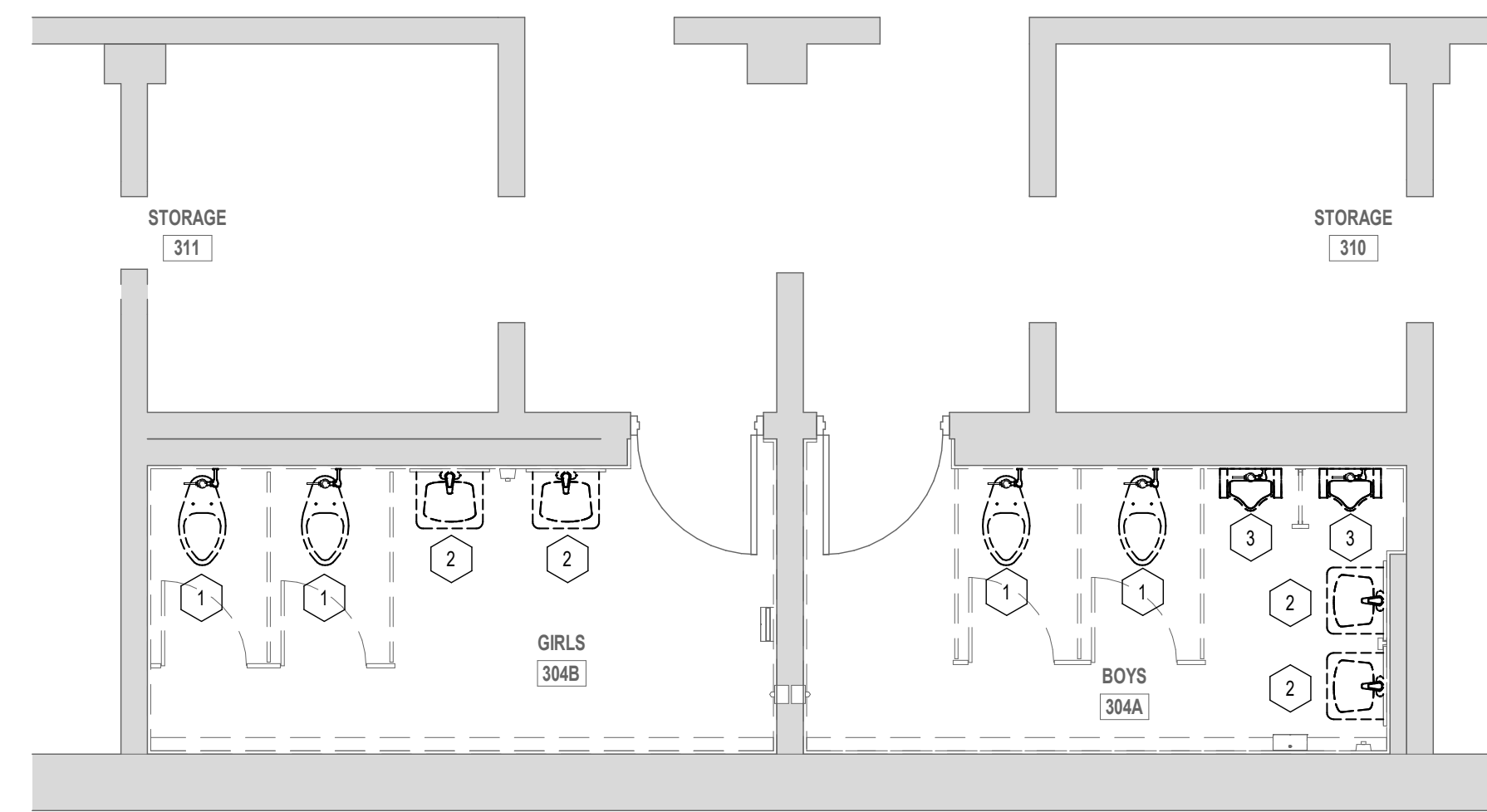

**1** 1ST FLOOR GYM - PLUMBING DEMOLITION FLOOR PLAN  
1/4" = 1'-0"

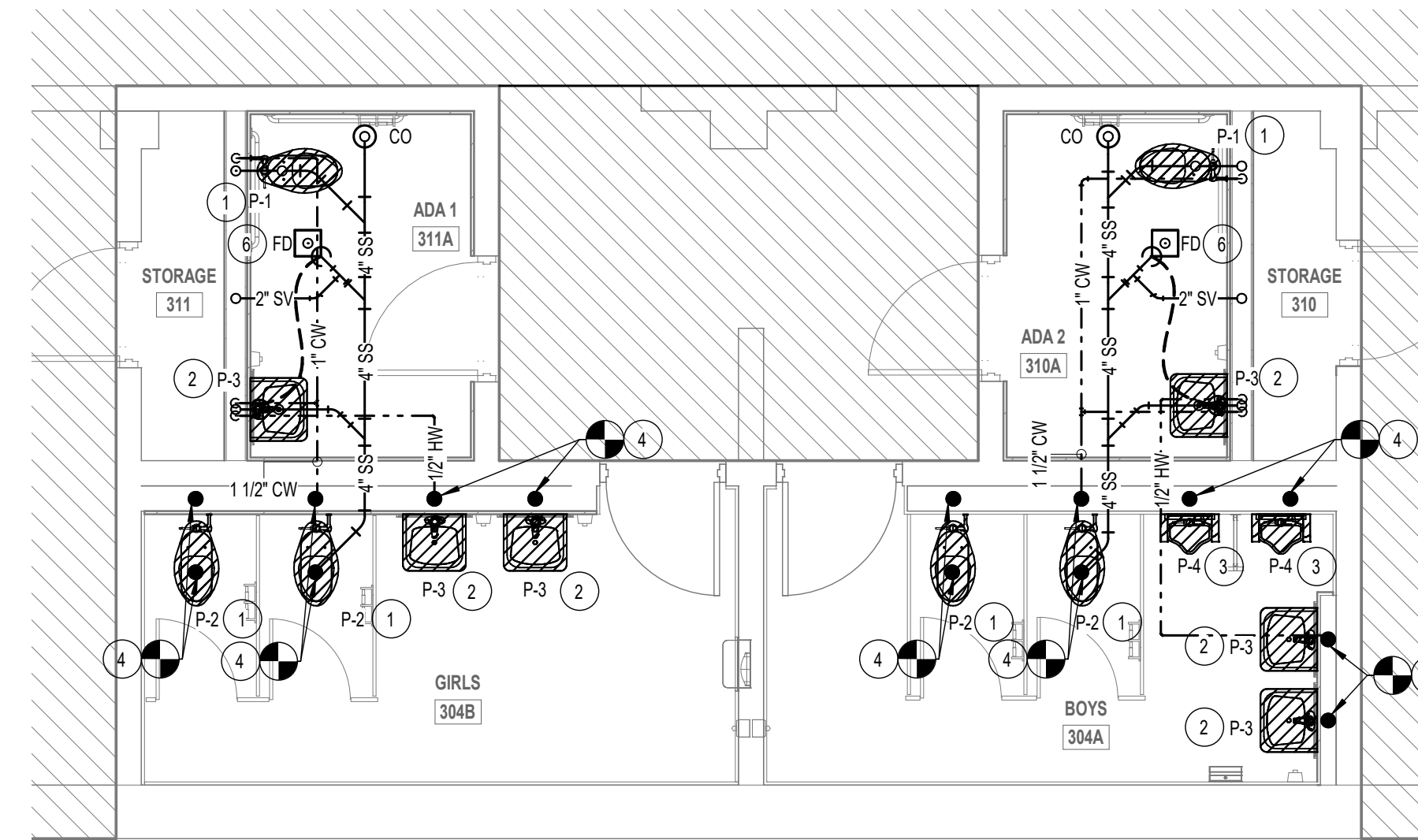

**2** 1ST FLOOR GYM - PLUMBING FLOOR PLAN  
1/4" = 1'-0"

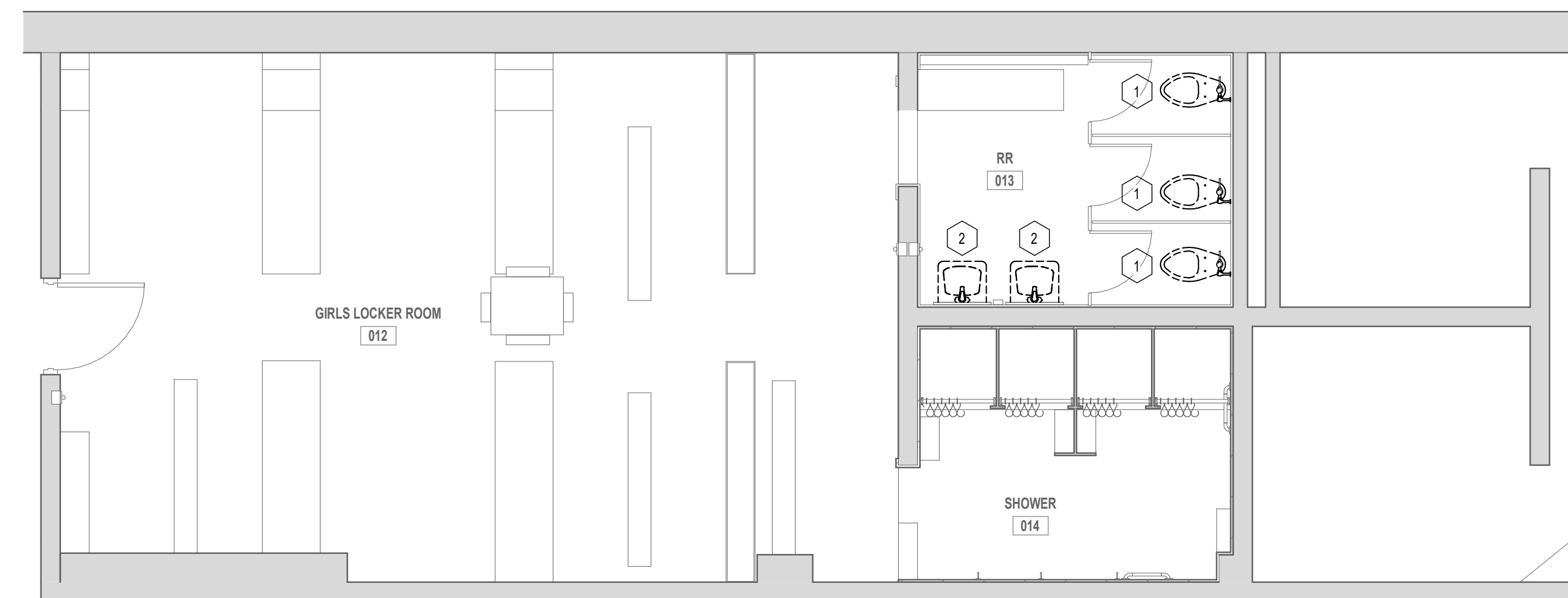

**3** ENLG 1ST FLOOR - B - NEW LOCKER ROOM PLUMBING DEMOLITION FLOOR PLAN  
1/4" = 1'-0"

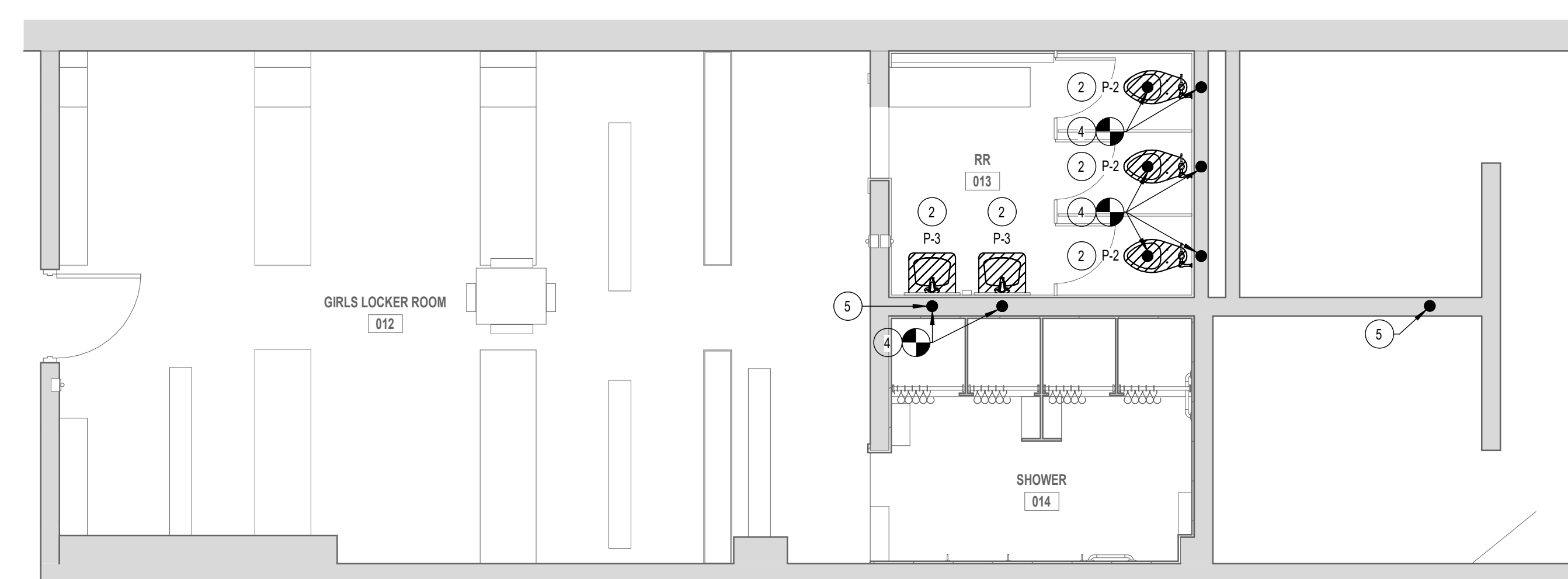

**4** ENLG 1ST FLOOR - B - NEW LOCKER ROOM PLUMBING FLOOR PLAN  
1/4" = 1'-0"

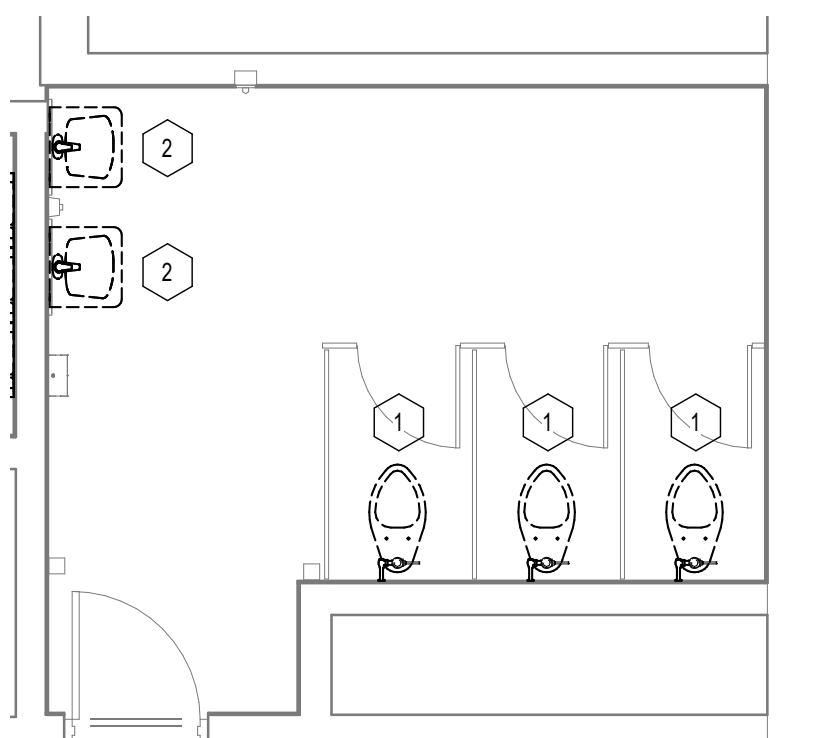

**5** 2ND FLOOR GIRLS - PLUMBING DEMOLITION FLOOR PLAN  
1/4" = 1'-0"

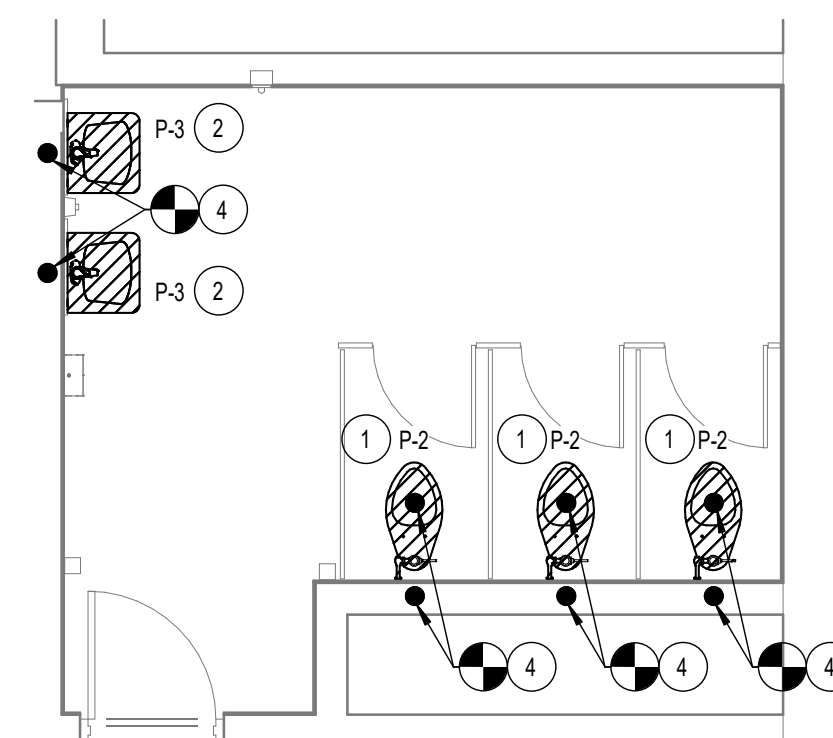

**6** 2ND FLOOR GIRLS - PLUMBING FLOOR PLAN  
1/4" = 1'-0"

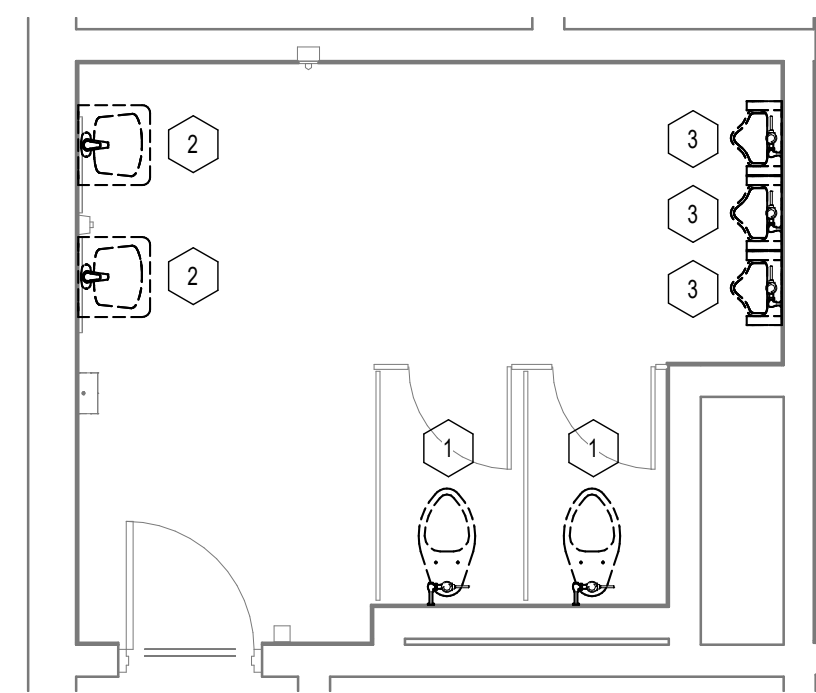

**7** 2ND FLOOR BOYS - PLUMBING DEMOLITION FLOOR PLAN  
1/4" = 1'-0"

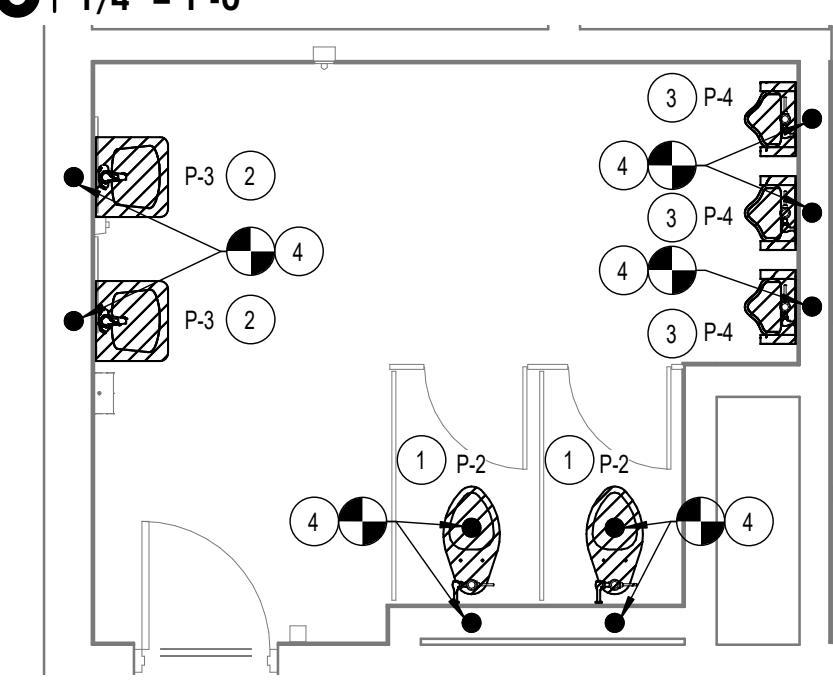

**8** 2ND FLOOR BOYS - PLUMBING FLOOR PLAN  
1/4" = 1'-0"

**PLUMBING DEMO NOTES**

- CONTRACTOR TO REMOVE EXISTING WATER CLOSET IN BOLD DASHED LINES. TEMPORARILY CAP EXISTING SANITARY SEWER IN FLOOR AND DOMESTIC WATER IN WALL. PREPARE FOR INSTALLATION OF NEW. RE: PLUMBING FLOOR PLAN THIS SHEET.
- CONTRACTOR TO REMOVE EXISTING LAVATORY IN BOLD DASHED LINES. TEMPORARILY CAP EXISTING SANITARY SEWER AND DOMESTIC WATER IN WALL. PREPARE FOR INSTALLATION OF NEW. RE: PLUMBING FLOOR PLAN THIS SHEET.
- CONTRACTOR TO REMOVE EXISTING URINAL IN BOLD DASHED LINES. TEMPORARILY CAP EXISTING SANITARY SEWER AND DOMESTIC WATER IN WALL. PREPARE FOR INSTALLATION OF NEW. RE: PLUMBING FLOOR PLAN THIS SHEET.

**PLUMBING PLAN NOTES**

- 4"W., 3"W., 1" CW., TO SERVE WATER CLOSET, TYPICAL.
- 2"W., 2", 1/2" H&CW., TO SERVE LAVATORY, TYPICAL.
- 2"W., 2", 3/4" CW., TO SERVE URINAL, TYPICAL.
- CONTRACTOR TO CONNECT TO EXISTING SANITARY SEWER AND DOMESTIC WATER SERVICE IN APPROXIMATE LOCATION SHOWN. VERIFY EXACT SIZE, LOCATION, AND DIRECTION OF FLOW OF EXISTING ON JOB SITE AND CONNECT TO EXISTING SERVICES OF SUFFICIENT SIZE. CONTRACTOR SHALL SAWCUT AS REQUIRED.
- PROVIDE 2" HUB DRAIN IN PLUMBING VENT IN WALL FOR AHU CONDENSATE.
- 3"W., 2", 1/2" TRAP PRIMER TO SERVE FLOOR DRAIN, TYPICAL.

ARCHITECT

DOMAIN ARCHITECTURE

8316 kelwood avenue, baton rouge, la 70806  
t: 225.216.3770 f: 225.216.3771  
www.domain-dsgn.com

REGISTRATION

These drawings are the property of DOMAIN ARCHITECTURE APC and are not to be reproduced in whole or in part. They are only to be used for the project and site specifically identified herein. Scales stated herein are valid on the original drawing only. Contractor shall carefully review all dimensions and conditions shown and report to the architect any errors, inconsistencies, or omissions discovered. These plans were prepared in the office under our personal supervision, and to the best of our knowledge comply with state and local codes. We will generally administer construction.

CLIENT

Southern University Laboratory School  
**BATHROOM RENOVATIONS**

129 SWAN AVE,  
BATON ROUGE, LA 70813

PROJECT INFORMATION

revisions	No.	Description	Date

project # C22-0072  
date September 5, 2023  
director review

# PLUMBING FIXTURE SCHEDULE

- NOTES:  
 1. CLEANOUT SHALL BE SAME SIZE AS SANITARY SEWER PIPE  
 2. FLOOR DRAIN TO BE INSTALLED WITH 1/2" TRAP PRIMER; SEE PLANS FOR SANITARY SEWER AND VENT CONNECTION SIZES

MARK	FIXTURE DESCRIPTION	ACCEPTABLE MANUFACTURERS	CARRIER	FAUCET	TRIM		CONNECTION SIZE				NOTES	
					FLUSHVALVE	MISCELLANEOUS ITEMS	CW DIA	HW DIA	VENT DIA	SAN DIA		
CO	SANITARY FLOOR CLEANOUT	ZURN ZN1400; WADE 6000-STD; JAY R SMITH 4031 SERIES; JOSAM 55000; MIFAB C1220										1
FD	FLOOR DRAIN WITH 6" SQUARE ADJUSTABLE NICKEL BRONZE STRAINER AND CAST IRON BODY	JAY R SMITH 2005; WADE 1100G; ZURN Z415S; JOSAM 3000-S; MIFAB F1100-S										2
P-1	FLOOR MOUNTED WHITE VITREOUS WATER CLOSET W/ TOP SPUD AND 1.6 GPF FLUSH VALVE; ADA COMPLIANT	AMERICAN STANDARD 3461.160; KOHLER K-4368; ZURN Z5665-BWL				SLOAN ROYAL 111; ZURN Z6000AV-WS1; DELANY S402-1.6	SEAT: BENEKE 527 SS; CHURCH 9500 SSCT; AMERICAN STANDARD 5905.100SS; ZURN Z5956SS-EL-ST; BEMIS 1956SSCT	1"	3"	4"		
P-2	FLOOR MOUNTED WHITE VITREOUS WATER CLOSET W/ TOP SPUD AND 1.6 GPF FLUSH VALVE	AMERICAN STANDARD 2234.001; KOHLER K-4350; ZURN Z5665-BWL				SLOAN ROYAL 111; ZURN Z6000AV-WS1; DELANY S402-1.6	SEAT: BENEKE 527 SS; CHURCH 9500 SSCT; AMERICAN STANDARD 5905.100SS; ZURN Z5956SS-EL-ST; BEMIS 1956SSCT	1"	3"	4"		
P-3	20" X 18" WALL HUNG WHITE VITREOUS CHINA LAVATORY WITH OVERFLOW AND 4" CENTER FAUCET HOLES	AMERICAN STANDARD 0124.131; KOHLER K-1729; ZURN Z5344	JAY R. SMITH 0700; ZURN Z1231; JOSAM 17100; MIFAB MC-41	AMERICAN STANDARD 7385.003; T&S BRASS B-2711; ZURN Z81000-G, ELKAY LK422L4; DELTA 523L-HDF			1-1/4" CAST BRASS "P" TRAP WITH CLEAN OUT; 3/8" ANGLE STOP SUPPLIES WITH LOOSE KEY STOP; "P" TRAP AND SUPPLIES TO BE PROTECTED WITH TRUEBRO LAV GUARD; GRID STRAINER DRAIN	1/2"	1/2"	2"	2"	
P-4	WALL MOUNTED WHITE VITREOUS CHINA URINAL WITH WASHOUT FLUSH ACTION (1.0 GPF) AND EXTENDED SIDES FOR PRIVACY; 3/4" TOP SPUD	AMERICAN STANDARD 6501.010; KOHLER K-4904-ET; ZURN Z5750; MANSFIELD 410HE	JAY R SMITH 0615; JOSAM 17560-UR; ZURN Z1222; MIFAB MC-32			ZURN Z6003AV-WS1; SLOAN ROYAL 186-1.0; DELANY S451-1		3/4"	2"	2"		

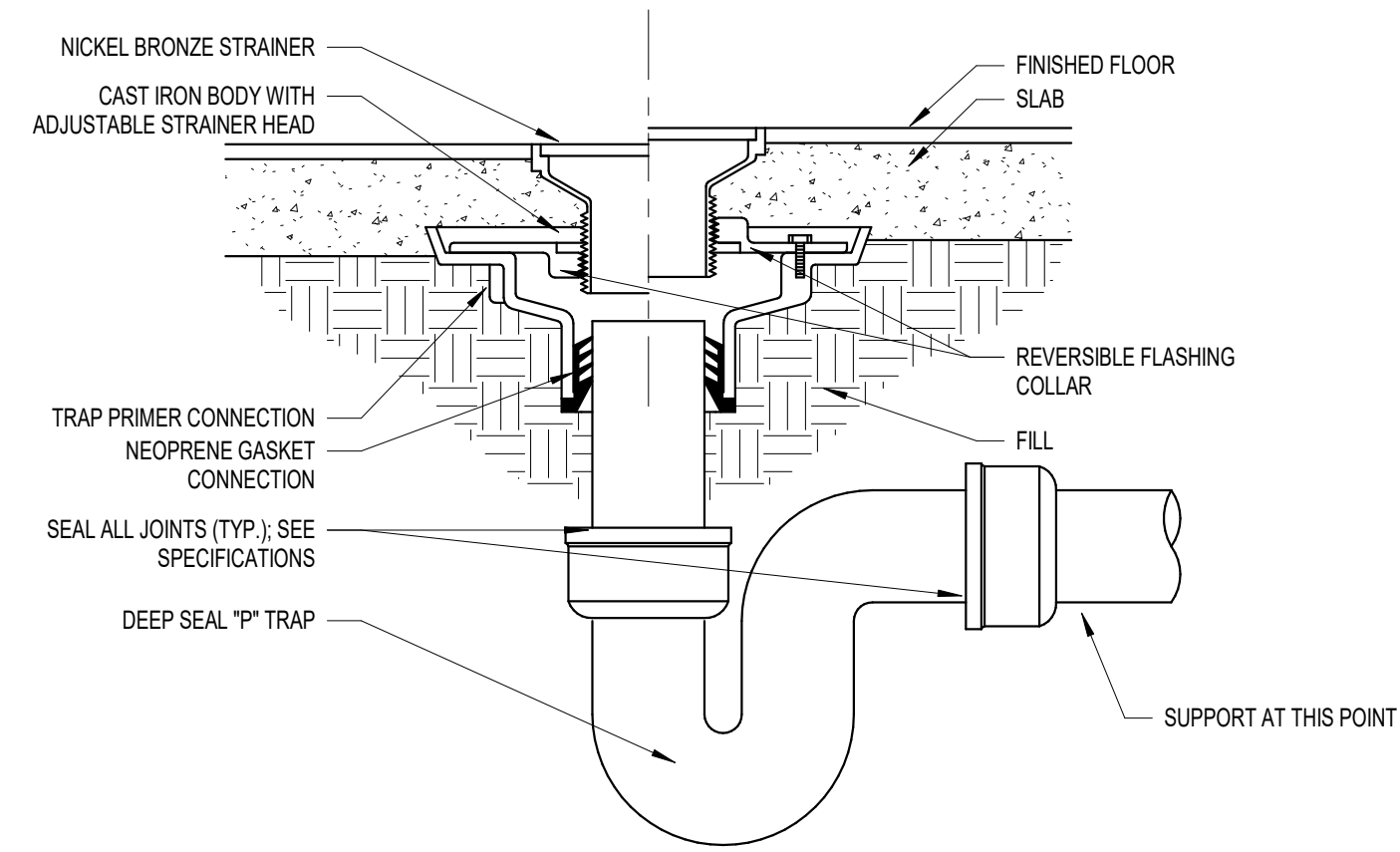

- GENERAL NOTES:  
 1. ALL FLOOR DRAINS SHALL BE INSTALLED WITH A 1/2" TRAP PRIMER.  
 2. COORDINATE ROUGH IN HEIGHT OF ALL FLOOR DRAINS WITH SLAB/FINISHED FLOOR HEIGHT PRIOR TO SLAB BEING POURED.

**1** DETAIL - FLOOR DRAIN  
NOT TO SCALE

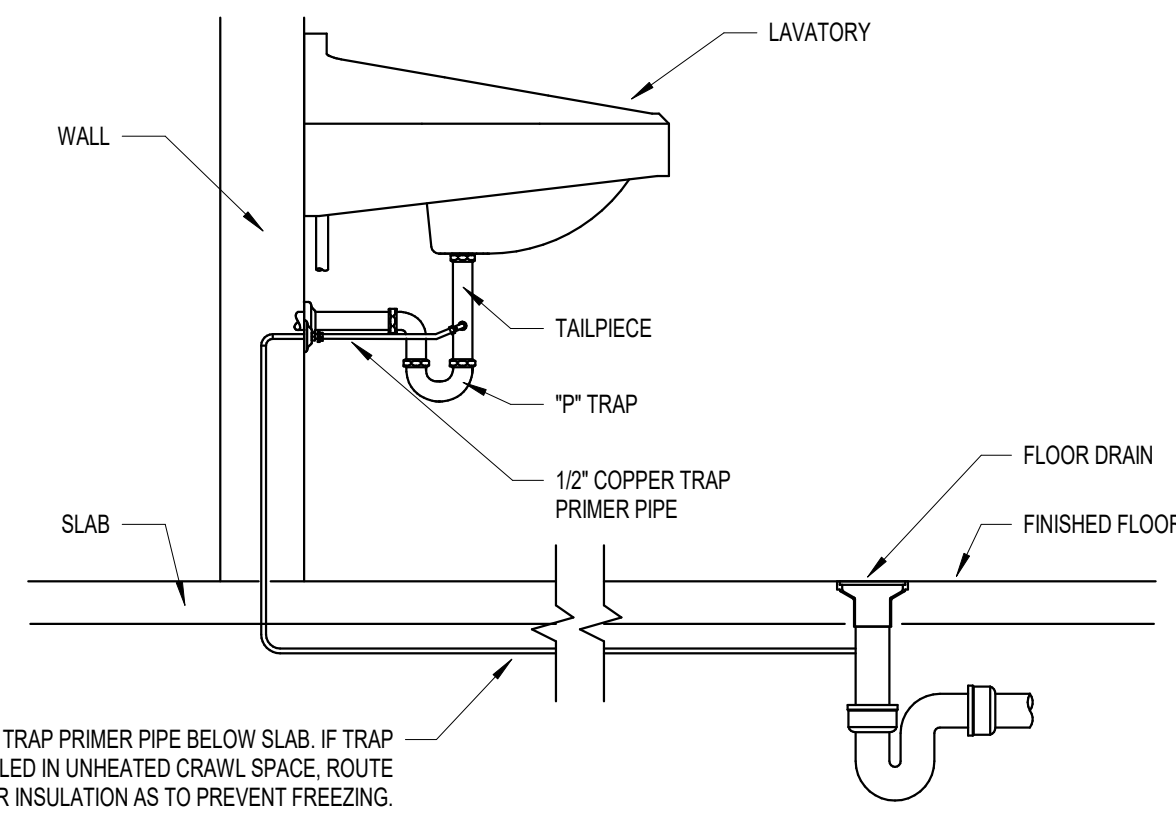

- 1/2" COPPER TRAP PRIMER PIPE BELOW SLAB. IF TRAP PRIMER IS INSTALLED IN UNHEATED CRAWL SPACE, ROUTE PIPE ABOVE FLOOR INSULATION AS TO PREVENT FREEZING.

- GENERAL NOTES:  
 1. ALL COPPER PIPING BELOW SLAB SHALL BE SOFT DRAWN WITH NO JOINTS. ALL COPPER PIPING ABOVE SLAB SHALL BE HARD DRAWN COPPER.

**2** DETAIL - GRAVITY TRAP PRIMER  
NOT TO SCALE

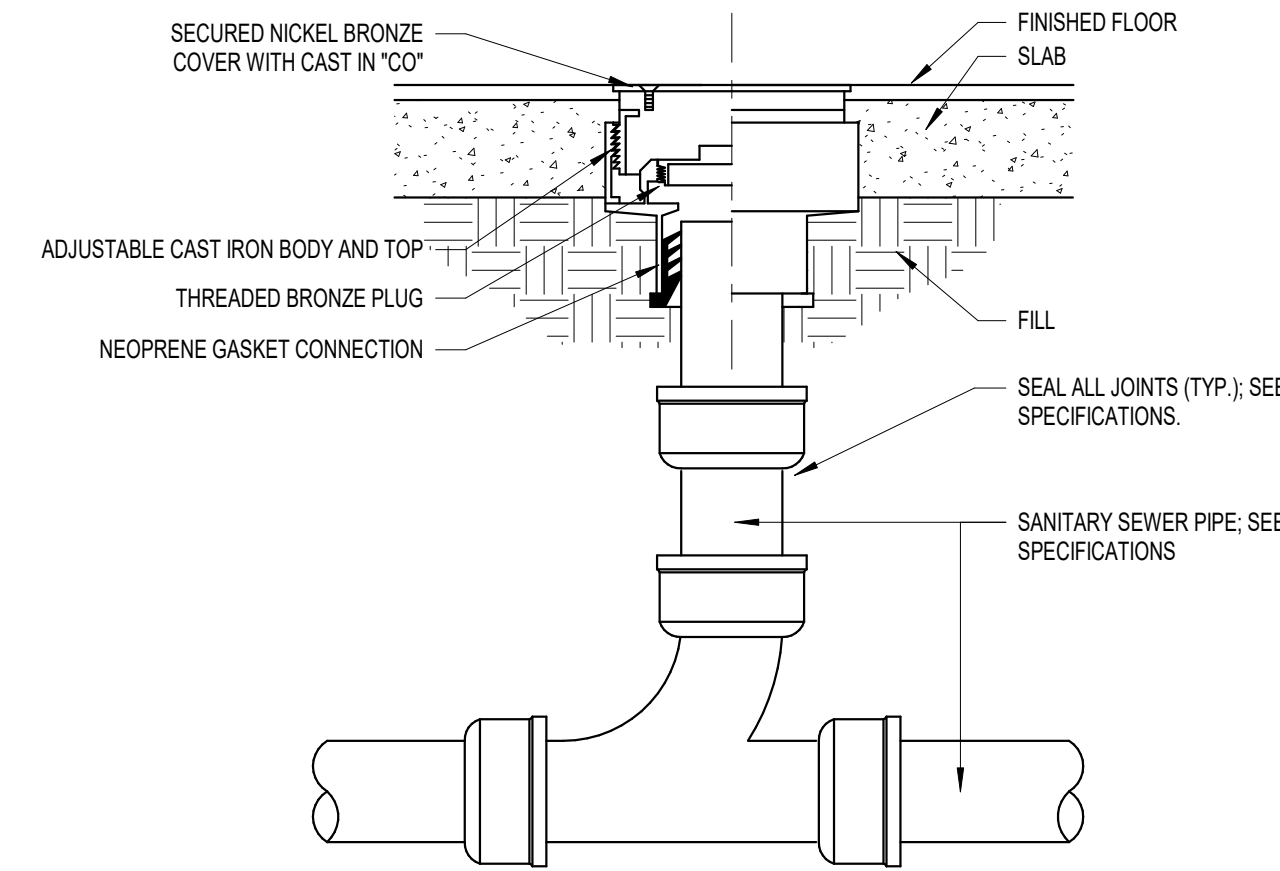

- GENERAL NOTES:  
 1. ALL CLEANOUTS SHALL BE INSTALLED WITH THE FOLLOWING MINIMUM CLEARANCES: 12" MIN. ON CLEANOUTS SMALLER THAN 3" AND 18" MIN. ON CLEANOUTS 3" AND LARGER.  
 2. CLEANOUTS SHALL BE LOCATED ALONG HORIZONTAL PIPING AT THE FOLLOWING MAXIMUM INTERVALS: 50'-0" MAX. ON PIPING 3" AND SMALLER AND 80'-0" MAX. ON PIPING 4" THROUGH 6".  
 3. COORDINATE ROUGH IN HEIGHT OF ALL CLEANOUTS WITH SLAB/FINISHED FLOOR HEIGHT PRIOR TO SLAB BEING POURED.

**3** DETAIL - INTERIOR CLEANOUT  
NOT TO SCALE

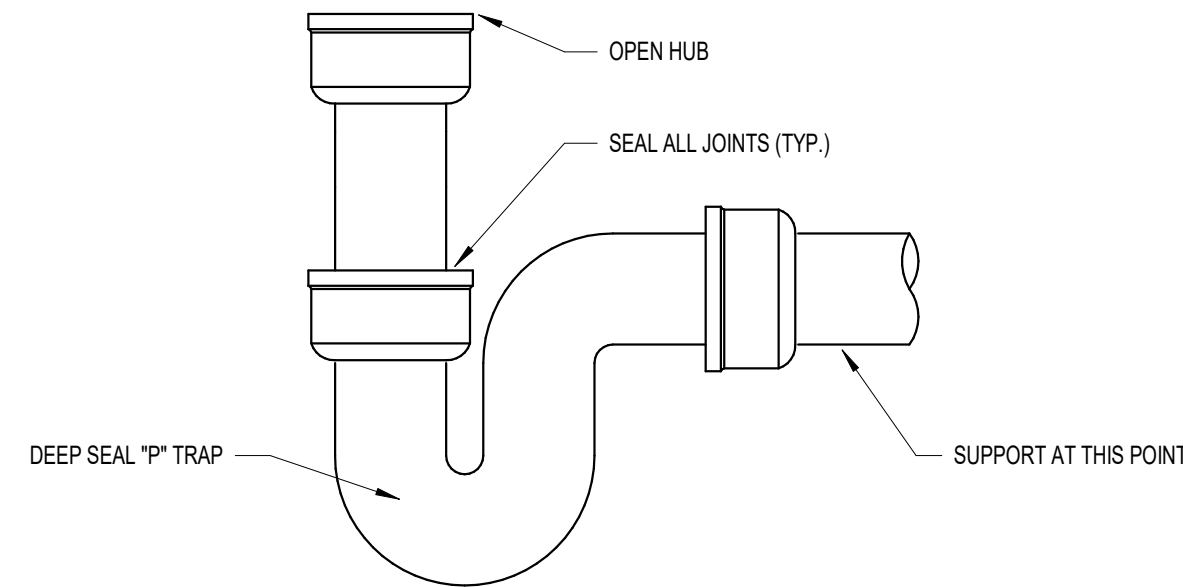

**4** DETAIL - HUB DRAIN  
NOT TO SCALE

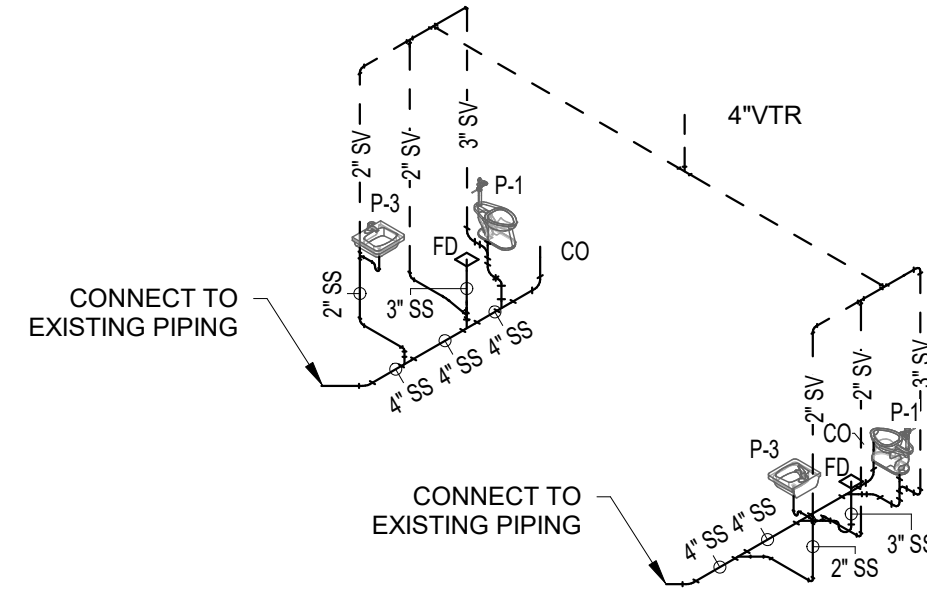

**5** SANITARY RISER DIAGRAM

These drawings are the property of DOMAIN ARCHITECTURE APC and are not to be reproduced in whole or in part. They are only to be used for the project and site specifically identified herein. Scales stated herein are valid on the original drawings only. Contractor shall carefully review all dimensions and conditions shown and report to the architect any errors, inconsistencies, or omissions discovered. These plans were prepared in this office under our personal supervision, and to the best of our knowledge comply with state and local codes. We will generally administer construction.

CLIENT

PROJECT INFORMATION

revisions	No.	Description	Date

project # C22-0072

date September 5, 2023

director review

PLUMBING SCHEDULES & DETAILS



**1** 1ST FLOOR - DEMOLITION OVERALL PLAN  
1/16" = 1'-0"

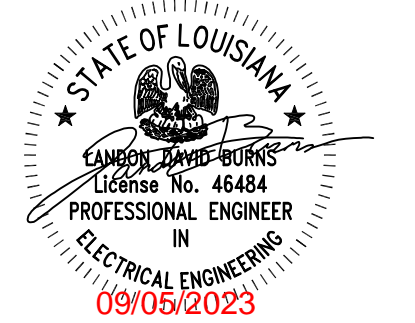
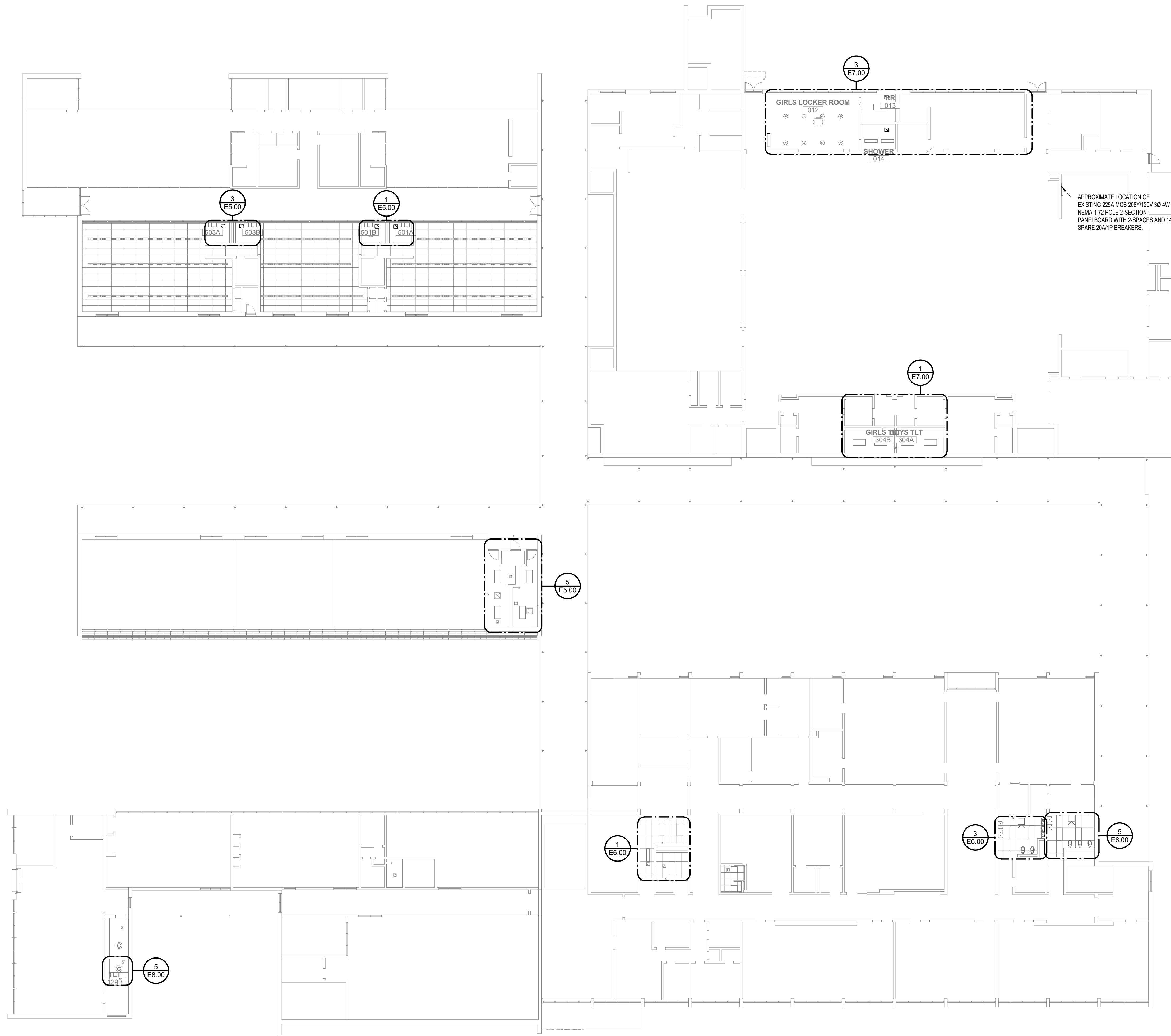

These drawings are the property of DOMAIN ARCHITECTURE APAC and are not to be reproduced in whole or in part. They are only to be used for the project and site specifically identified herein. Scales stated herein are valid on the original drawings only. Contractor shall carefully review all dimensions and conditions shown and report to the architect any errors, inconsistencies, or omissions discovered. These plans were prepared in the office under our personal supervision, and to the best of our knowledge comply with state and local codes.

Southern University Laboratory School  
**BATHROOM RENOVATIONS**

129 SWAN AVE,  
BATON ROUGE, LA 70813

revisions	No.	Description	Date

project # **C22-0072**

date **September 5, 2023**

director

OVERALL FIRST FLOOR  
DEMOLITION PLAN



**1** 1ST FLOOR - NEW CONSTRUCTION OVERALL PLAN  
 1/16" = 1'-0"

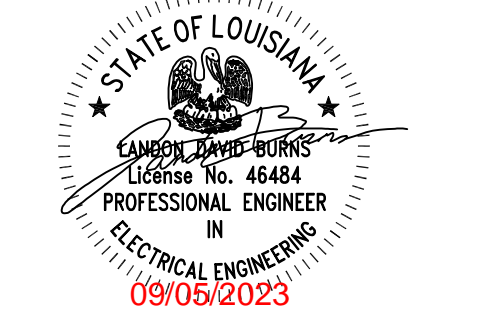
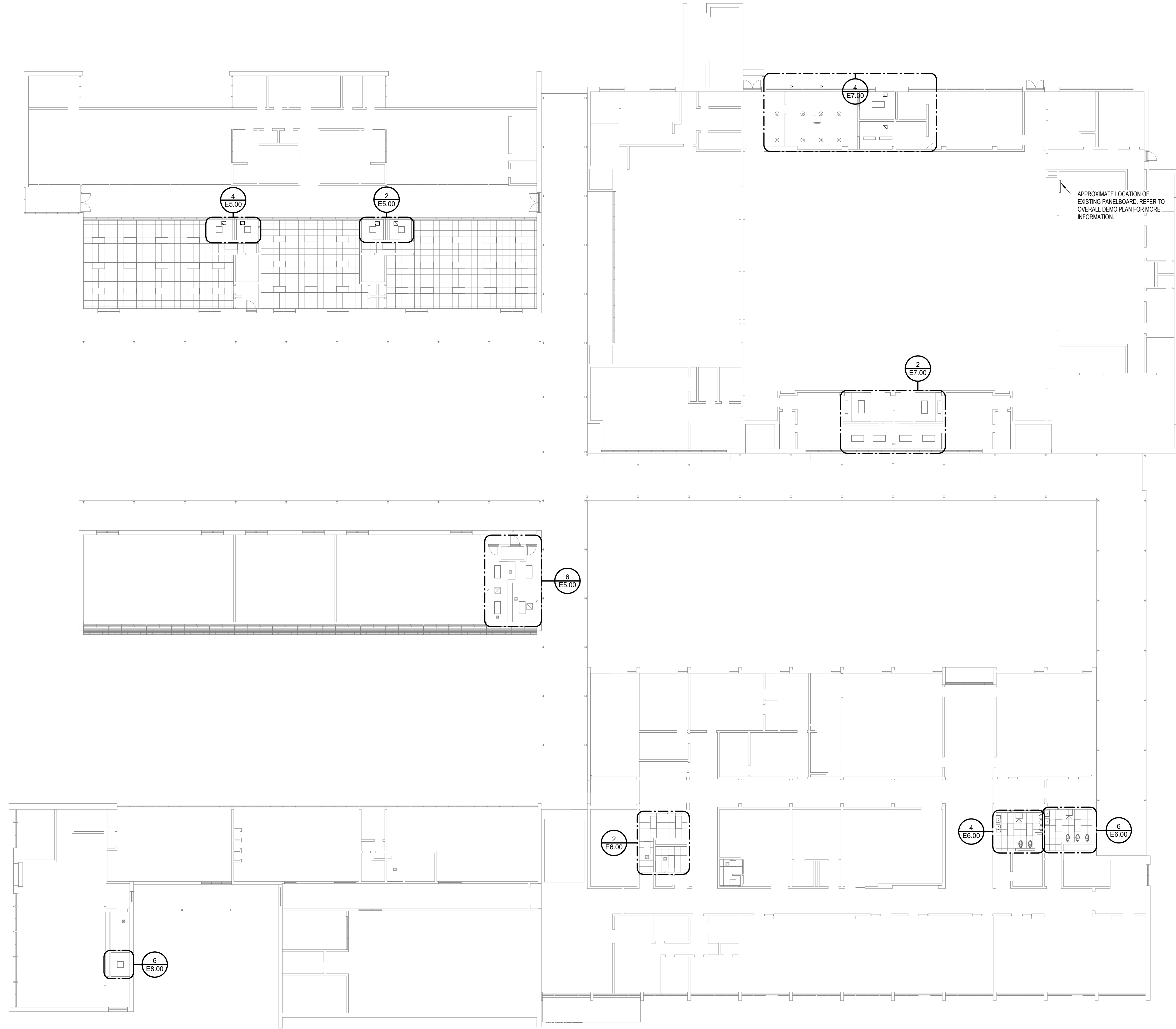

These drawings are the property of DOMAIN ARCHITECTURE, APC and are not to be reproduced in whole or in part. They are only to be used for the project and site specifically identified herein. Scales stated herein are valid on the original drawings only. Contractor shall carefully review all dimensions and conditions shown and report to the architect any errors, inconsistencies, or omissions discovered. These plans were prepared in the office under our personal supervision, and to the best of our knowledge comply with state and local codes.

Southern University Laboratory School  
**BATHROOM RENOVATIONS**  
 129 SWAN AVE.,  
 BATON ROUGE, LA 70813

revisions	No.	Description	Date

project # **C22-0072**

date **September 5, 2023**

director

**OVERALL FIRST FLOOR  
 NEW CONSTRUCTION  
 PLAN**

**E2.00**



**1** 2ND FLOOR - DEMOLITION OVERALL PLAN  
1/8" = 1'-0"

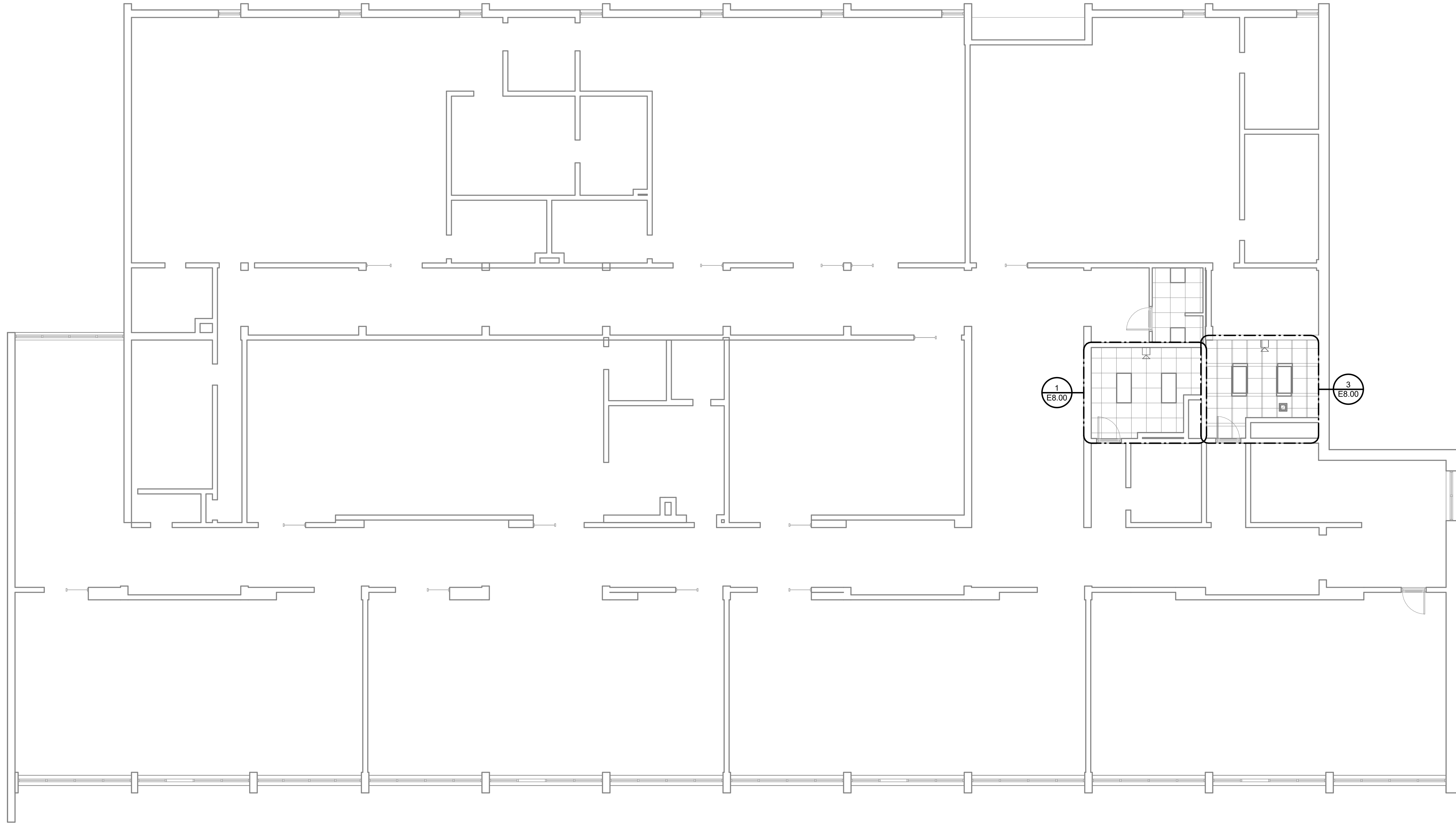

**DOMAIN**  
ARCHITECTURE  
APAC

8316 Kelwood Avenue Baton Rouge, LA 70806  
t: 225.216.2779 f: 225.216.2771  
www.domain-design.com

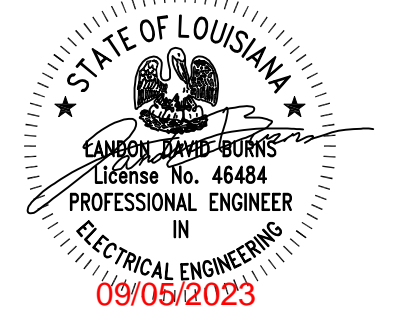

These drawings are the property of DOMAIN ARCHITECTURE APAC and are not to be reproduced in whole or in part. They are only to be used for the project and site specifically identified herein. Scales stated herein are valid on the original drawings only. Contractor shall carefully review all dimensions and conditions shown and report to the architect any errors, inconsistencies, or omissions discovered. These plans were prepared in the office under our personal supervision, and to the best of our knowledge comply with state and local

Southern University Laboratory School  
**BATHROOM RENOVATIONS**

129 SWAN AVE,  
BATON ROUGE, LA 70813

revisions	No.	Description	Date

project # **C22-0072**

date **September 5, 2023**

director

OVERALL SECOND  
FLOOR DEMOLITION  
PLAN

**E3.00**

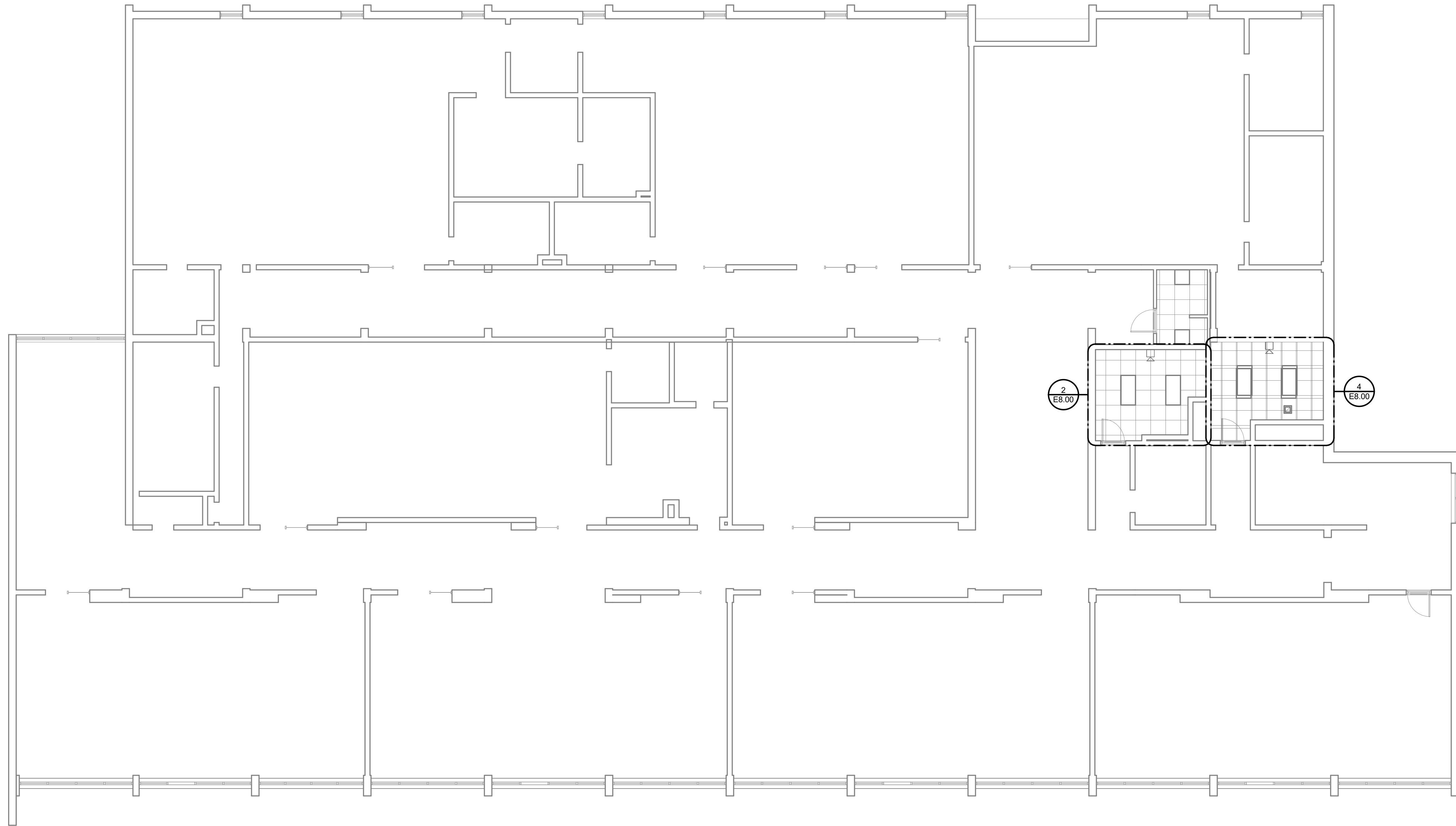

**1** 2ND FLOOR - NEW CONSTRUCTION OVERALL PLAN  
 1/8" = 1'-0"

ARCHITECT

**DOMAIN**  
 ARCHITECTURE  
 8316 kelwood avenue, baton rouge, la 70806  
 t: 225.216.3770 f: 225.216.3771  
 www.domain-arch.com

REGISTRATION

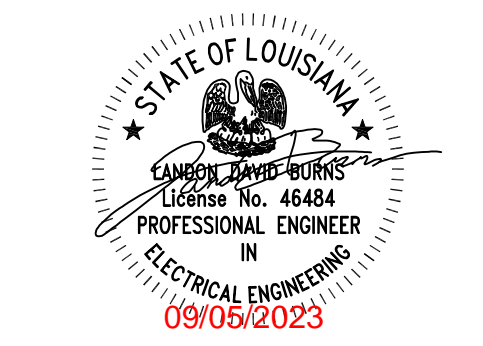

These drawings are the property of DOMAIN ARCHITECTURE APAC and are not to be reproduced in whole or in part. They are only to be used for the project and site specifically identified herein. Scales stated herein are valid on the original drawings only. Contractor shall carefully review all dimensions and conditions shown and report to the architect any errors, inconsistencies, or omissions discovered. These plans were prepared in the office under our personal supervision, and to the best of our knowledge comply with state and local

CLIENT

Southern University Laboratory School  
**BATHROOM RENOVATIONS**  
 129 SWAN AVE,  
 BATON ROUGE, LA 70813

PROJECT

revisions	No.	Description	Date

project # **C22-0072**

date **September 5, 2023**

director

OVERALL SECOND  
 FLOOR NEW  
 CONSTRUCTION PLAN

**E4.00**

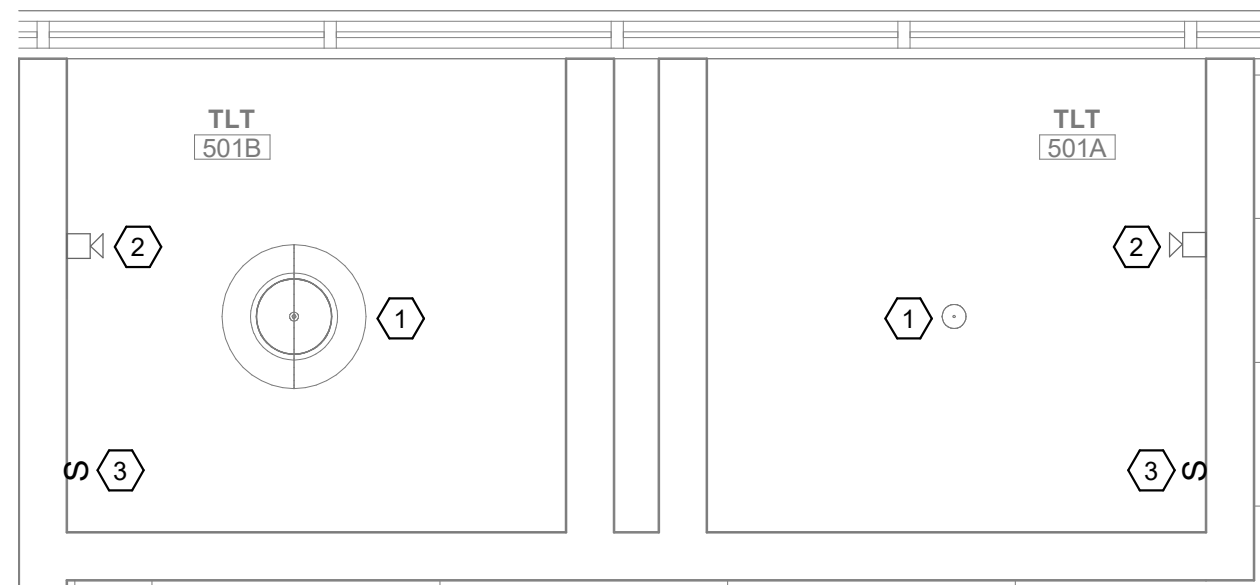

**1** KINDERGARDEN TLT 501A & 501B - DEMOLITION RCP  
3/8" = 1'-0"

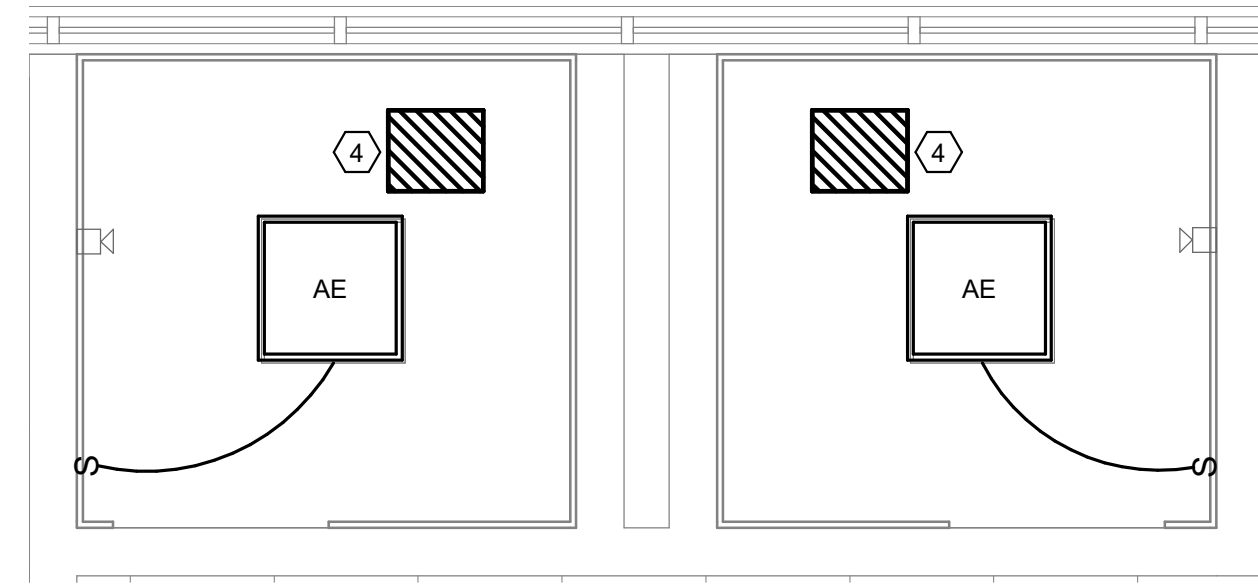

**2** KINDERGARDEN TLT 501A & 501B - NEW CONSTRUCTION RCP  
3/8" = 1'-0"

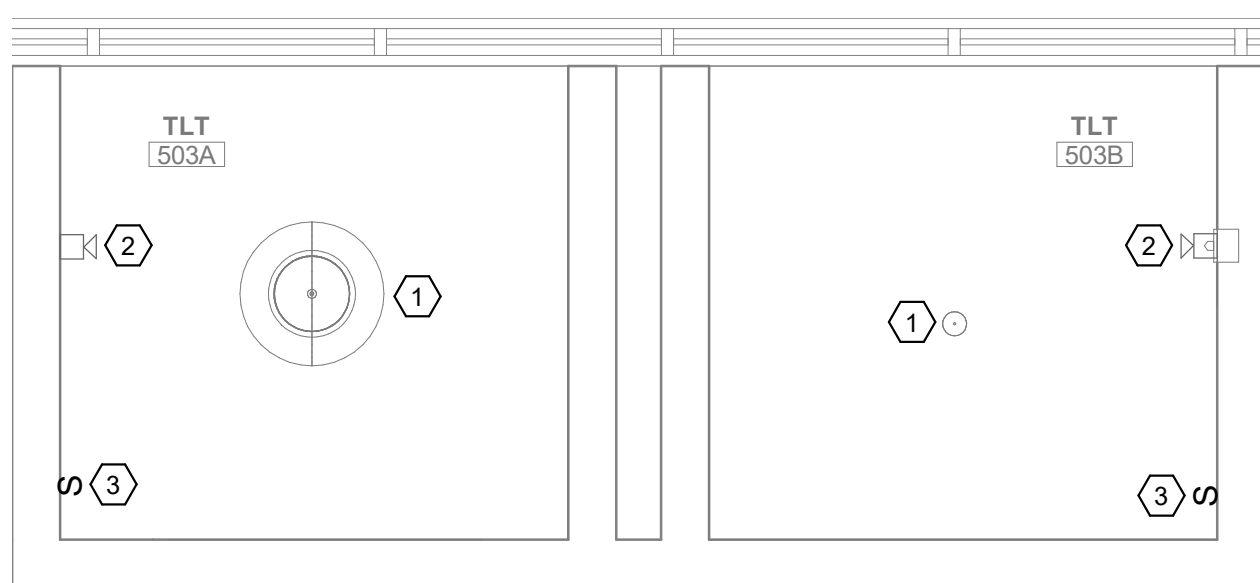

**3** KINDERGARDEN TLT 503A & 503B - DEMOLITION RCP  
3/8" = 1'-0"

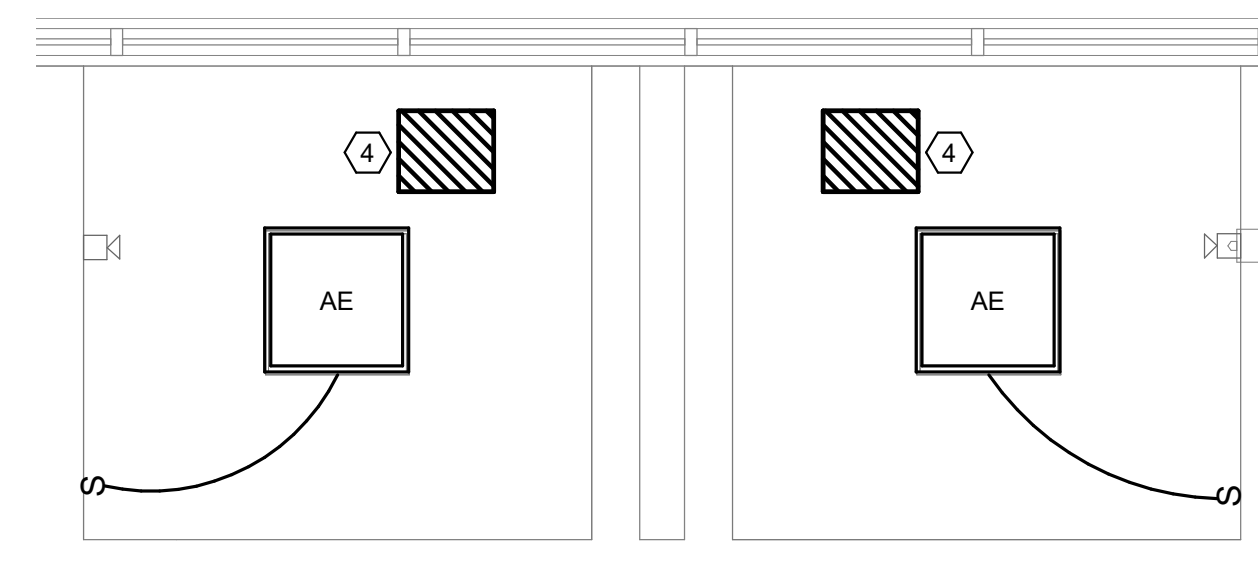

**4** KINDERGARDEN TLT 503A & 503B - NEW CONSTRUCTION RCP  
3/8" = 1'-0"

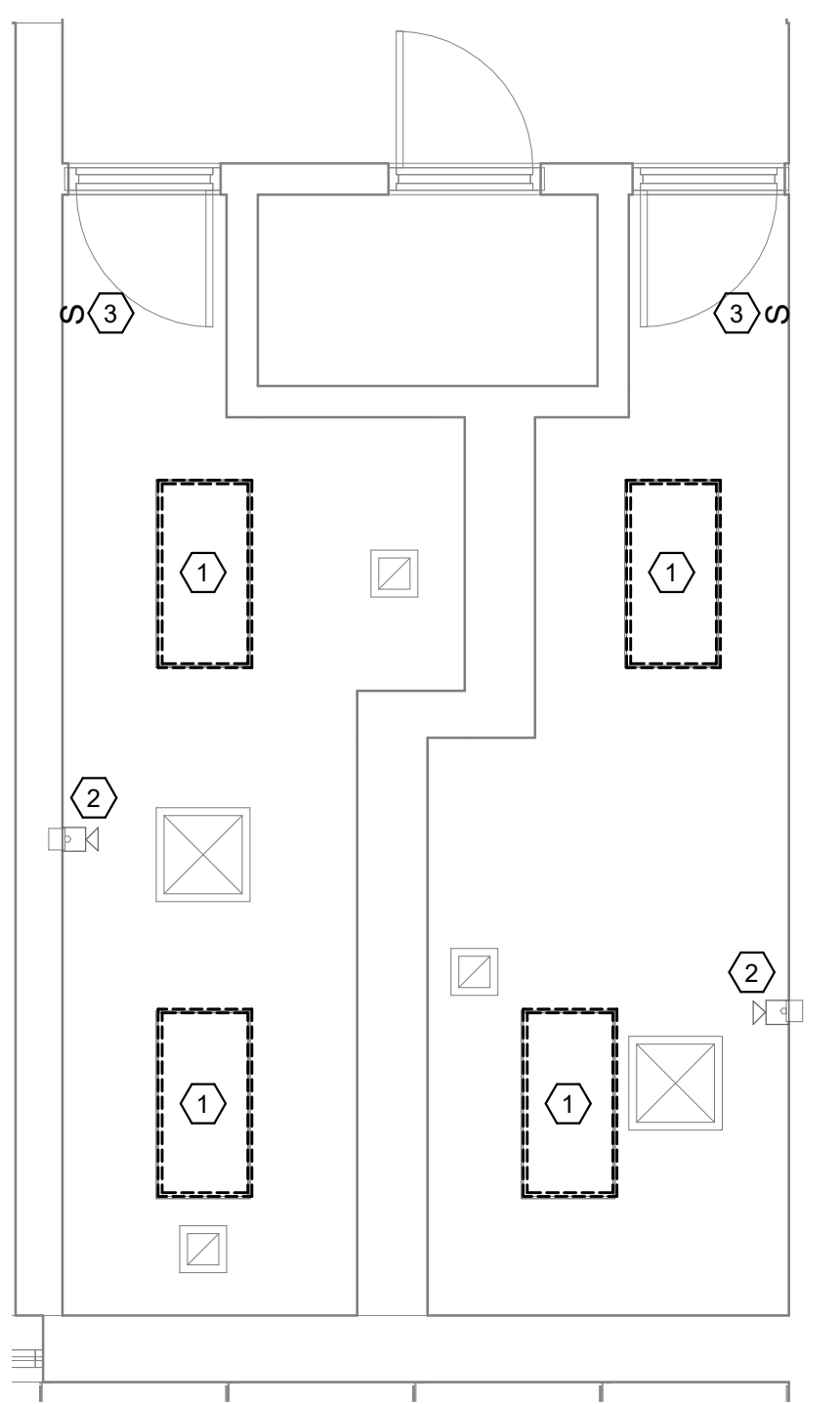

**5** EXTERIOR RESTROOM - DEMOLITION RCP  
1/4" = 1'-0"

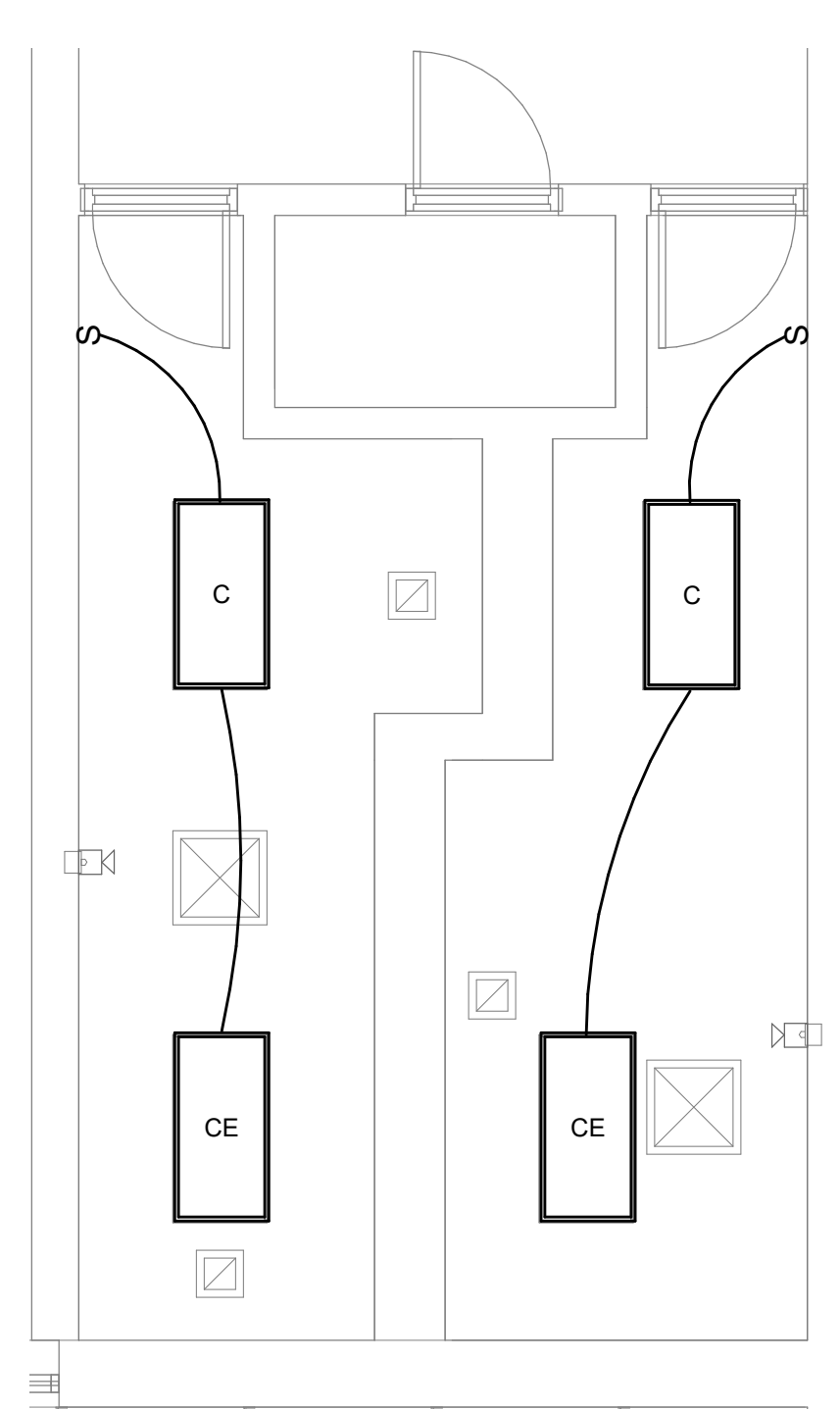

**6** EXTERIOR RESTROOM - NEW CONSTRUCTION RCP  
1/4" = 1'-0"

**ELECTRICAL GENERAL NOTES**

- 1. CONNECT ALL NEW SWITCHES TO EXISTING SWITCH CIRCUITS. EXTEND EXISTING CIRCUITS TO NEW LOCATION; REFER TO DEMO PLAN FOR EXISTING LOCATION. PROVIDE 2#12, 1#12 GND AND 3/4" CONDUIT AS REQUIRED.
- 2. CONNECT ALL NEW LIGHTING TO EXISTING LIGHTING CIRCUITS FOR POWER AND CONTROL. UNLESS OTHERWISE INDICATED, PROVIDE 2#12, 1#12 GND AND 3/4" CONDUIT AS REQUIRED.

**ELECTRICAL KEYED NOTES**

- ① DISCONNECT AND REMOVE EXISTING LIGHTING FIXTURES. EXISTING LIGHTING CIRCUITRY SHALL REMAIN AND BE RE-USED. MODIFY EXISTING CIRCUITRY AS REQUIRED TO ACCOMMODATE NEW CONTROLS.
- ② EXISTING FIRE ALARM STROBE SHALL BE REMOVED PRIOR TO DEMOLITION AND REINSTALLED DURING CONSTRUCTION. PROTECT AND SUPPORT EXISTING CIRCUITS AND WIRING DURING DEMOLITION.
- ③ DISCONNECT AND REMOVE EXISTING SWITCH. MOVE EXISTING CIRCUITRY TO ACCESSIBLE LOCATION ABOVE CEILING OR IN WALL TO REMAIN. MODIFY EXISTING CIRCUITRY AS REQUIRED TO ACCOMMODATE NEW DEVICE DURING DEMOLITION.
- ④ CONNECT EXHAUST FAN TO ASSOCIATED ROOM LIGHTING CIRCUIT. PROVIDE 2#12, 1#12 GND AND 3/4" CONDUIT AS REQUIRED.

ARCHITECT

DOMAIN ARCHITECTURE

8316 kelwood avenue  
Baton Rouge, La 70806  
t: 225.216.3770 f: 225.216.3771  
www.domain-arch.com

REGISTRATION

These drawings are the property of DOMAIN ARCHITECTURE, APAC and are not to be reproduced in whole or in part. They are only to be used for the project and site specifically identified herein. Scales stated herein are valid on the original drawings only. Contractor shall carefully review all dimensions and conditions shown and report to the architect any errors, inconsistencies, or omissions discovered. These plans were prepared in the office under our personal supervision, and to the best of our knowledge comply with state and local.

CLIENT

Southern University Laboratory School  
**BATHROOM RENOVATIONS**

129 SWAN AVE,  
BATON ROUGE, LA 70813

PROJECT

revisions	No.	Description	Date

project # **C22-0072**  
date **September 5, 2023**  
director

ENLARGED ELECTRICAL PLANS

**E5.00**

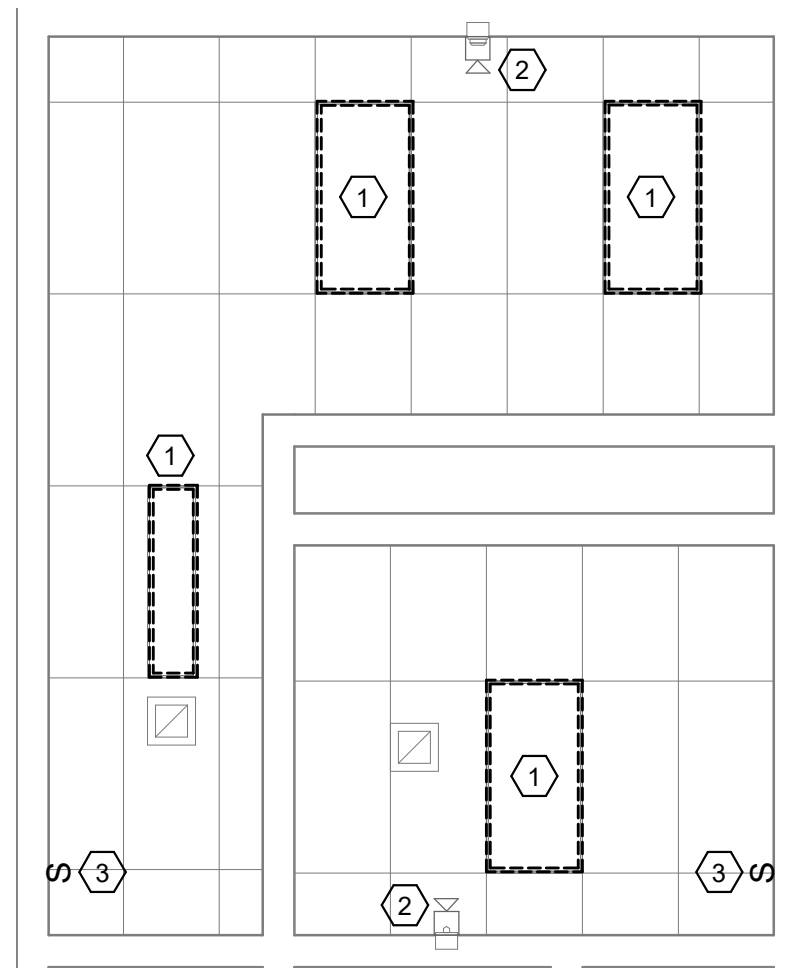

**1** STAFF RESTROOM 114 & 115 - DEMOLITION RCP  
1/4" = 1'-0"

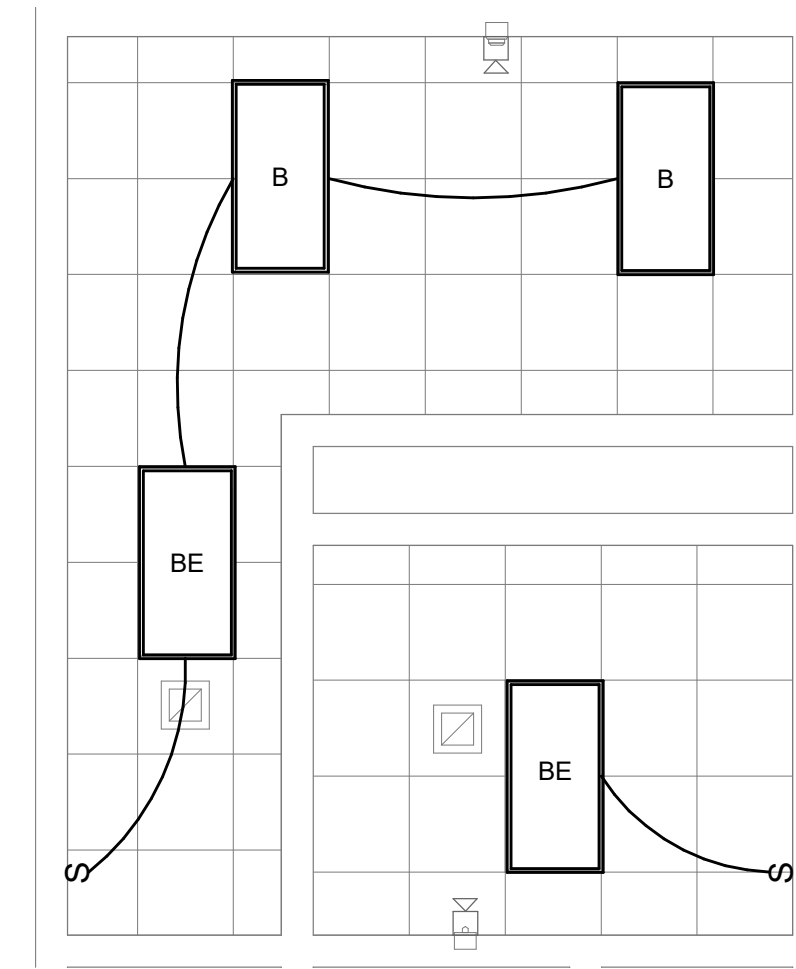

**2** STAFF RESTROOM 114 & 115 - NEW CONSTRUCTION RCP  
1/4" = 1'-0"

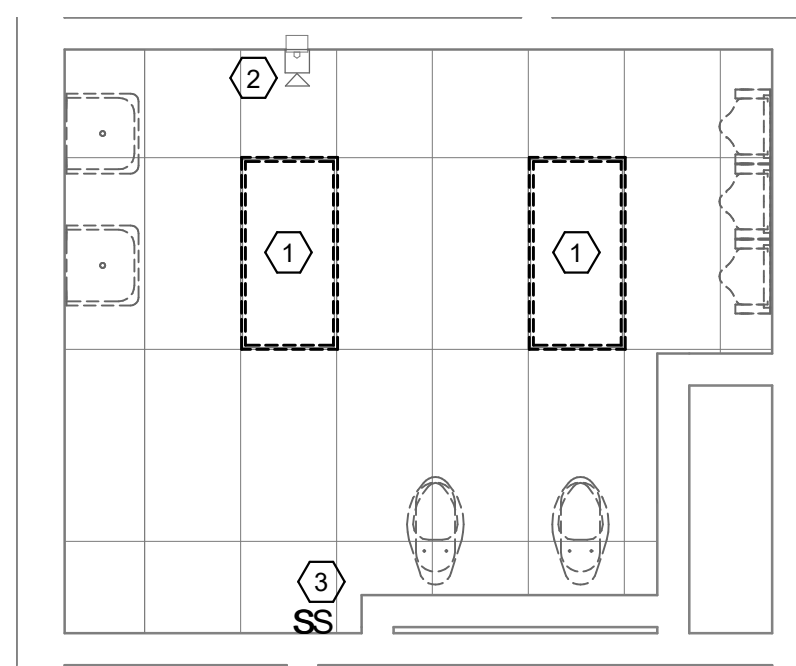

**3** BOYS RESTROOM 108 - DEMOLITION RCP  
1/4" = 1'-0"

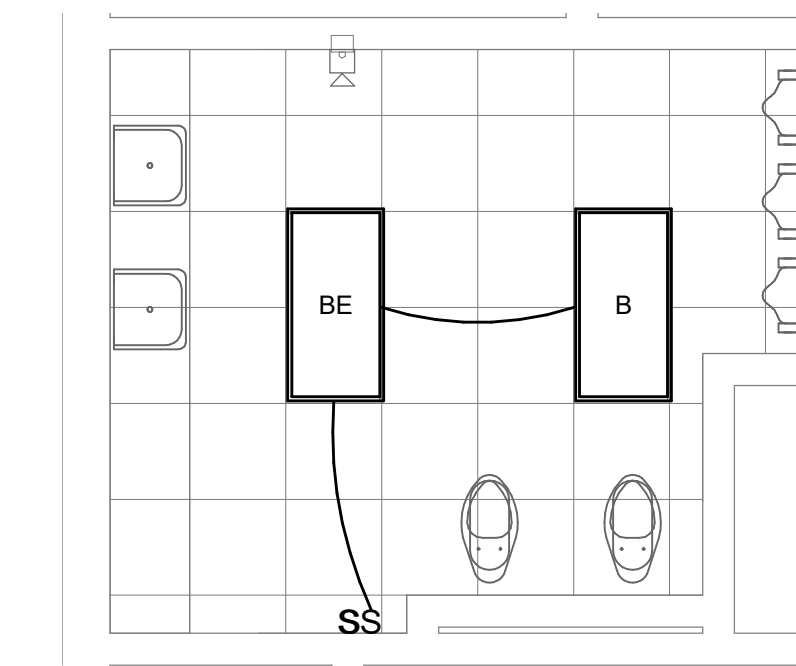

**4** BOYS RESTROOM 108 - NEW CONSTRUCTION RCP  
1/4" = 1'-0"

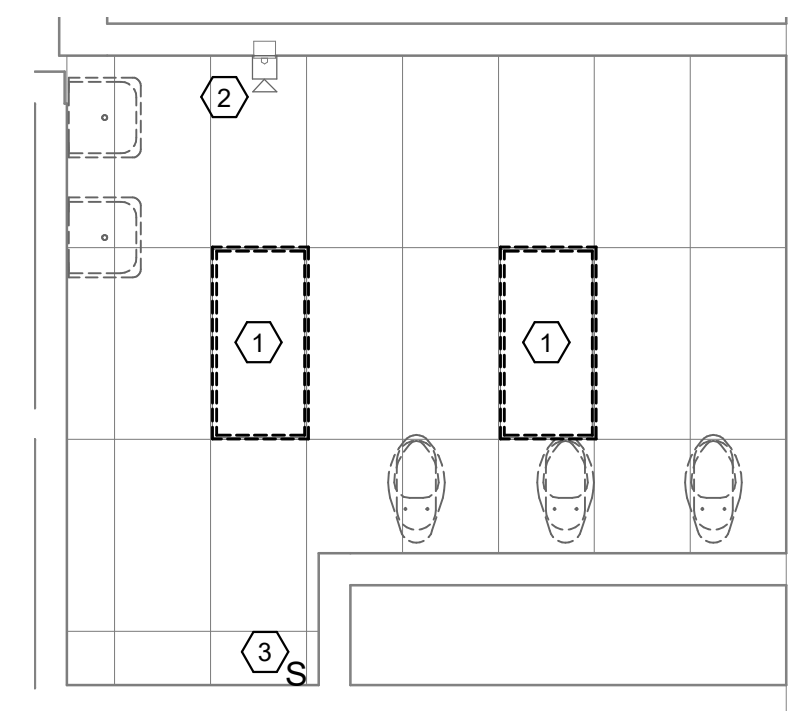

**5** GIRLS RESTROOM 107 - DEMOLITION RCP  
1/4" = 1'-0"

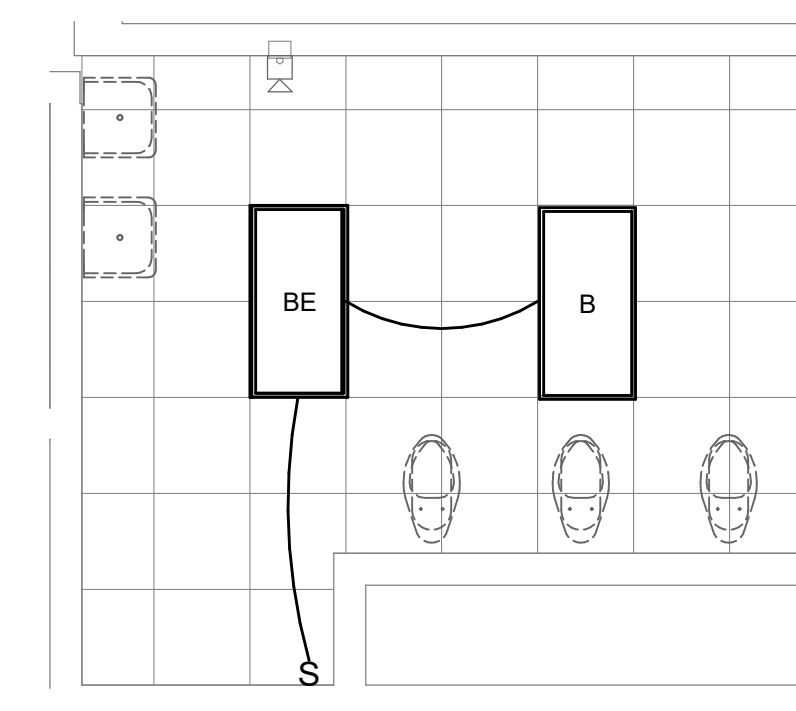

**6** GIRLS RESTROOM 107 - NEW CONSTRUCTION RCP  
1/4" = 1'-0"

- ELECTRICAL GENERAL NOTES**
- CONNECT ALL NEW SWITCHES TO EXISTING SWITCH CIRCUITS. EXTEND EXISTING CIRCUITS TO NEW LOCATION. REFER TO DEMO PLAN FOR EXISTING LOCATION. PROVIDE 2#12, 1#12 GND AND 3/4" CONDUIT AS REQUIRED.
  - CONNECT ALL NEW LIGHTING TO EXISTING LIGHTING CIRCUITS FOR POWER AND CONTROL UNLESS OTHERWISE INDICATED. PROVIDE 2#12, 1#12 GND AND 3/4" CONDUIT AS REQUIRED.

- ELECTRICAL KEYED NOTES**
- DISCONNECT AND REMOVE EXISTING LIGHTING FIXTURES. EXISTING LIGHTING CIRCUITRY SHALL REMAIN AND BE RE-USED. MODIFY EXISTING CIRCUITRY AS REQUIRED TO ACCOMMODATE NEW CONTROLS.
  - EXISTING FIRE ALARM STROBE SHALL BE REMOVED PRIOR TO DEMOLITION AND REINSTALLED DURING CONSTRUCTION. PROTECT AND SUPPORT EXISTING CIRCUITS AND WIRING DURING DEMOLITION.
  - DISCONNECT AND REMOVE EXISTING SWITCH. MOVE EXISTING CIRCUITRY TO ACCESSIBLE LOCATION ABOVE CEILING OR IN WALL TO REMAIN. MODIFY EXISTING CIRCUITRY AS REQUIRED TO ACCOMMODATE NEW DEVICE.



These drawings are the property of DOMAIN ARCHITECTURE APAC and are not to be reproduced in whole or in part. They are only to be used for the project and are specifically identified herein. Scales stated herein are valid on the original drawings only. Contractor shall carefully review all dimensions and conditions shown and report to the architect any errors, inconsistencies, or omissions discovered. These plans were prepared in the office under our personal supervision, and to the best of our knowledge comply with state and local.

CLIENT

Southern University Laboratory School  
**BATHROOM RENOVATIONS**

129 SWAN AVE,  
BATON ROUGE, LA 70813

PROJECT

revisions	No.	Description	Date

project # **C22-0072**  
date **September 5, 2023**  
director

ENLARGED ELECTRICAL PLANS

**E6.00**

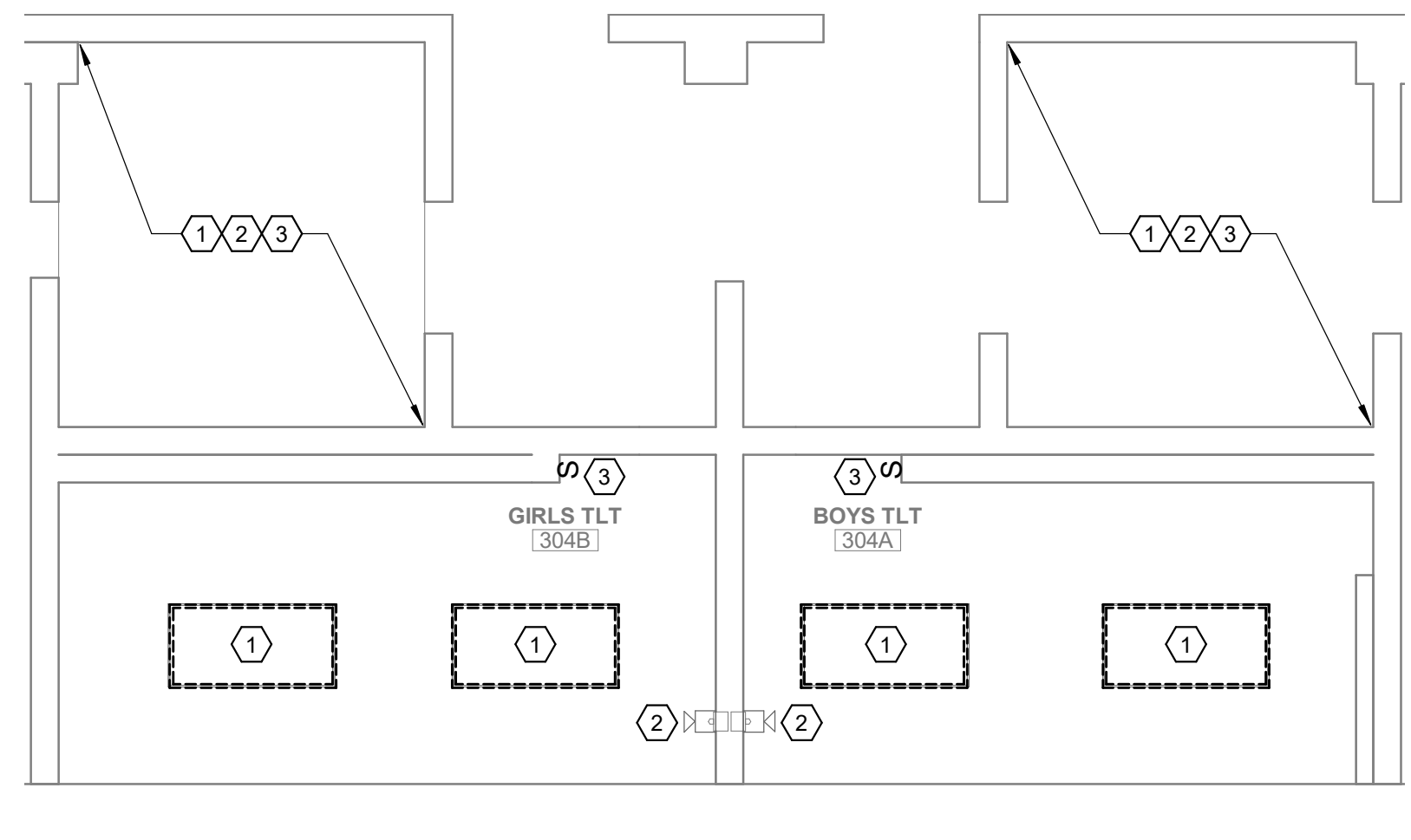

**1** | 1ST FLOOR GYM - DEMOLITION RCP  
1/4" = 1'-0"

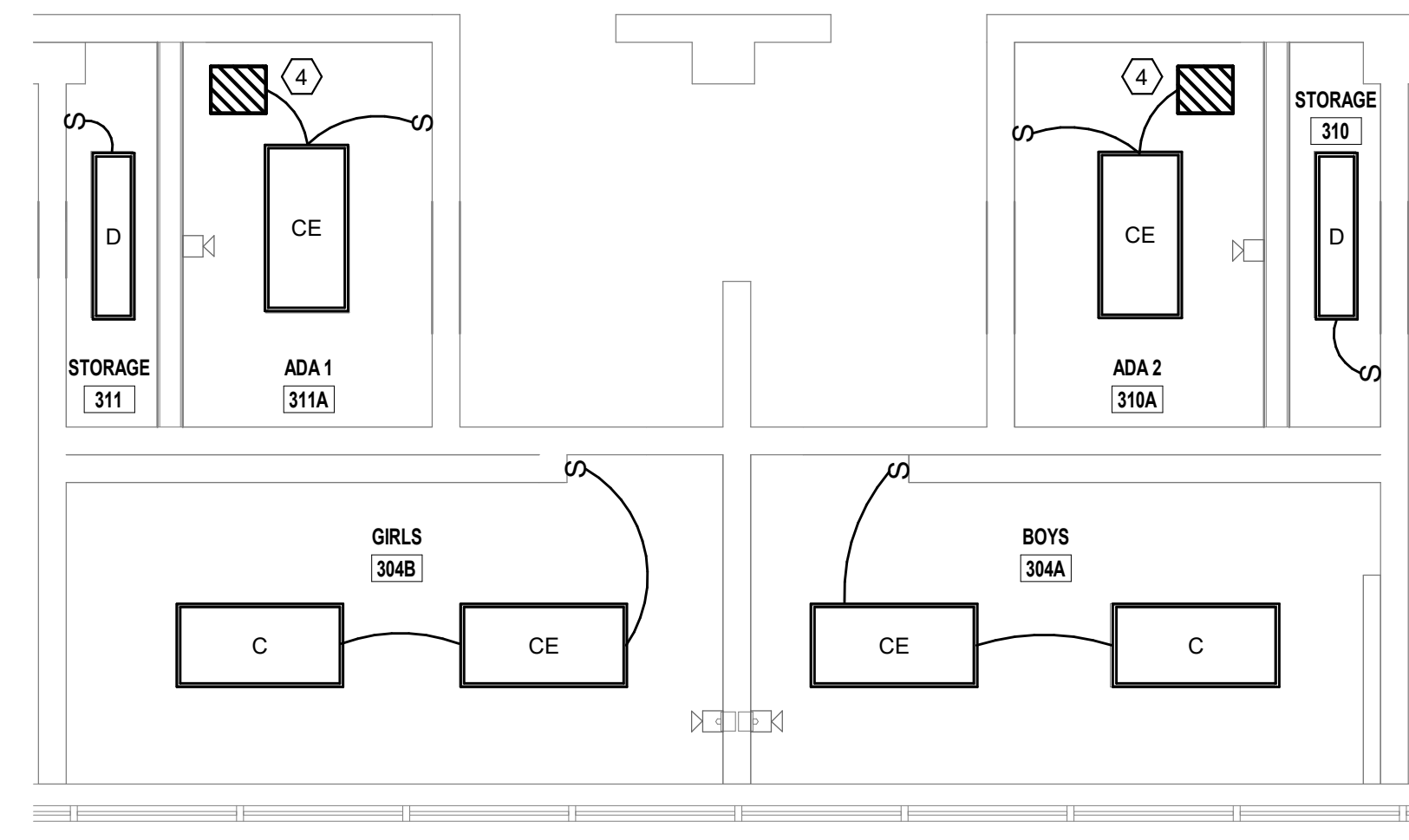

**2** | 1ST FLOOR GYM - NEW CONSTRUCTION RCP  
1/4" = 1'-0"

- ELECTRICAL GENERAL NOTES**
- CONNECT ALL NEW SWITCHES TO EXISTING SWITCH CIRCUITS. EXTEND EXISTING CIRCUITS TO NEW LOCATION; REFER TO DEMO PLAN FOR EXISTING LOCATION. PROVIDE 2#12, 1#12 GND AND 3/4" CONDUIT AS REQUIRED.
  - CONNECT ALL NEW LIGHTING TO EXISTING LIGHTING CIRCUITS FOR POWER AND CONTROL UNLESS OTHERWISE INDICATED. PROVIDE 2#12, 1#12 GND AND 3/4" CONDUIT AS REQUIRED.

- ELECTRICAL KEYED NOTES**
- DISCONNECT AND REMOVE EXISTING LIGHTING FIXTURES. EXISTING LIGHTING CIRCUITRY SHALL REMAIN AND BE RE-USED. MODIFY EXISTING CIRCUITRY AS REQUIRED TO ACCOMMODATE NEW CONTROLS.
  - EXISTING FIRE ALARM STROBE SHALL BE REMOVED PRIOR TO DEMOLITION AND REINSTALLED DURING CONSTRUCTION. PROTECT AND SUPPORT EXISTING CIRCUITS AND WIRING DURING DEMOLITION.
  - DISCONNECT AND REMOVE EXISTING SWITCH. MOVE EXISTING CIRCUITRY TO ACCESSIBLE LOCATION ABOVE CEILING OR IN WALL TO REMAIN. MODIFY EXISTING CIRCUITRY AS REQUIRED TO ACCOMMODATE NEW DEVICE.
  - CONNECT EXHAUST FAN TO ASSOCIATED ROOM LIGHTING CIRCUIT. PROVIDE 2#12, 1#12 GND AND 3/4" CONDUIT AS REQUIRED.
  - APPROXIMATE LOCATION OF NEW MINI-SPLIT. CONNECT TO ASSOCIATED OUTDOOR UNIT. PROVIDE 1" C. AND CABLING PER MANUFACTURER SPECIFICATIONS.
  - APPROXIMATE LOCATION OF NEW CONDENSING UNIT. CONNECT TO EXISTING PANEL ON STAGE. PROVIDE NEW 20A/2P BREAKER AND 3#12-1#12 GND AND 3/4" CONDUIT AS REQUIRED. REFER TO OVERALL FLOOR PLAN FOR MORE INFORMATION.
  - PROVIDE NEW 30A/2P/NF/NR DISCONNECT

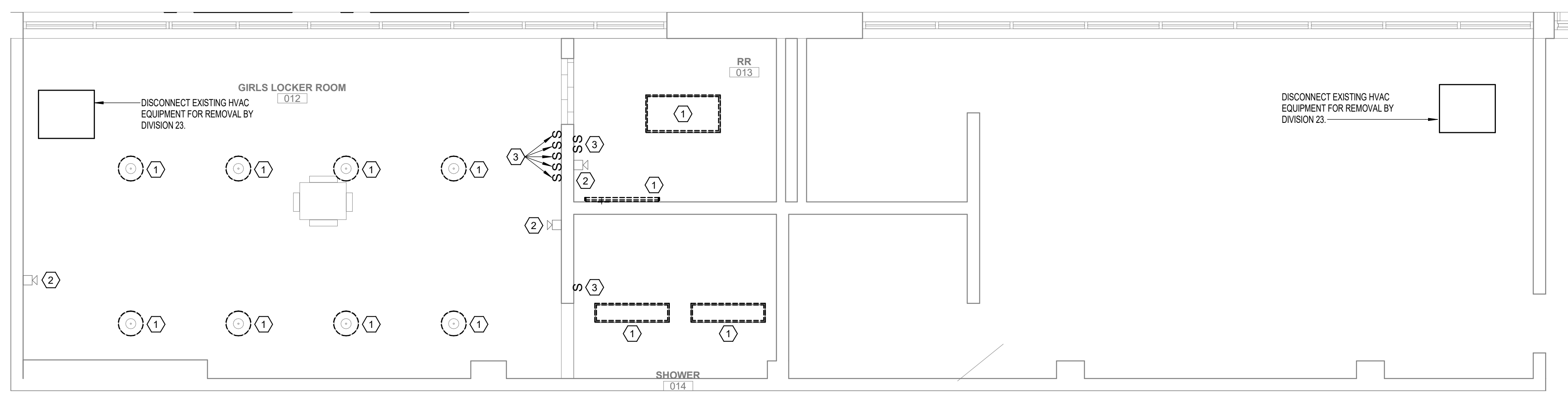

**3** | GIRLS LOCKER ROOM 012 - DEMOLITION RCP  
1/4" = 1'-0"

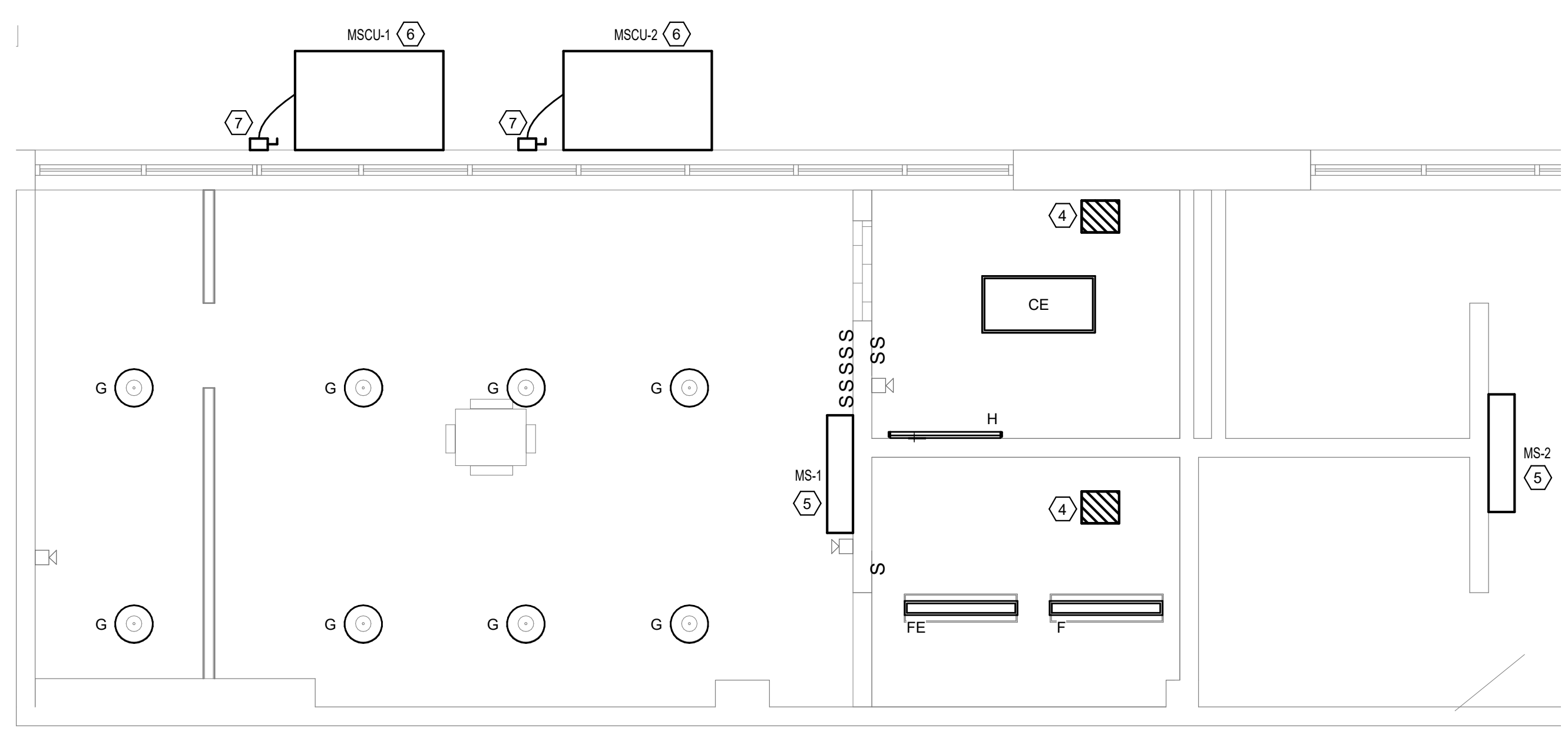

**4** | GIRLS LOCKER ROOM 012 - NEW CONSTRUCTION RCP  
1/4" = 1'-0"

ARCHITECT  
**DOMAIN ARCHITECTURE**  
8316 kelwood avenue, baton rouge, la 70806  
t: 225.216.3770 f: 225.216.3771  
www.domain-arch.com

REGISTRATION  
STATE OF LOUISIANA  
LAND AND SURVEYING  
License No. 46484  
PROFESSIONAL ENGINEER  
IN  
ELECTRICAL ENGINEERING  
09/05/2023

These drawings are the property of DOMAIN ARCHITECTURE APAC and are not to be reproduced in whole or in part. They are only to be used for the project and site specifically identified herein. Scales stated herein are valid on the original drawings only. Contractor shall carefully review all dimensions and conditions shown and report to the architect any errors, inconsistencies, or omissions discovered. These plans were prepared in the office under our personal supervision, and to the best of our knowledge comply with state and local.

CLIENT

Southern University Laboratory School  
**BATHROOM RENOVATIONS**  
PROJECT  
129 SWAN AVE.,  
BATON ROUGE, LA 70813

revisions	No.	Description	Date

project # **C22-0072**  
date **September 5, 2023**  
director

ENLARGED ELECTRICAL PLANS

**E7.00**

- ELECTRICAL GENERAL NOTES**
- CONNECT ALL NEW SWITCHES TO EXISTING SWITCH CIRCUITS. EXTEND EXISTING CIRCUITS TO NEW LOCATION. REFER TO DEMO PLAN FOR EXISTING LOCATION. PROVIDE 2#12, 1#12 GND AND 3/4" CONDUIT AS REQUIRED.
  - CONNECT ALL NEW LIGHTING TO EXISTING LIGHTING CIRCUITS FOR POWER AND CONTROL UNLESS OTHERWISE INDICATED. PROVIDE 2#12, 1#12 GND AND 3/4" CONDUIT AS REQUIRED.

- ELECTRICAL KEYED NOTES**
- DISCONNECT AND REMOVE EXISTING LIGHTING FIXTURES. EXISTING LIGHTING CIRCUITRY SHALL REMAIN AND BE RE-USED. MODIFY EXISTING CIRCUITRY AS REQUIRED TO ACCOMMODATE NEW CONTROLS.
  - EXISTING FIRE ALARM STROBE SHALL BE REMOVED PRIOR TO DEMOLITION AND REINSTALLED DURING CONSTRUCTION. PROTECT AND SUPPORT EXISTING CIRCUITS AND WIRING DURING DEMOLITION.
  - DISCONNECT AND REMOVE EXISTING SWITCH. MOVE EXISTING CIRCUITRY TO ACCESSIBLE LOCATION ABOVE CEILING OR IN WALL TO REMAIN. MODIFY EXISTING CIRCUITRY AS REQUIRED TO ACCOMMODATE NEW DEVICE.

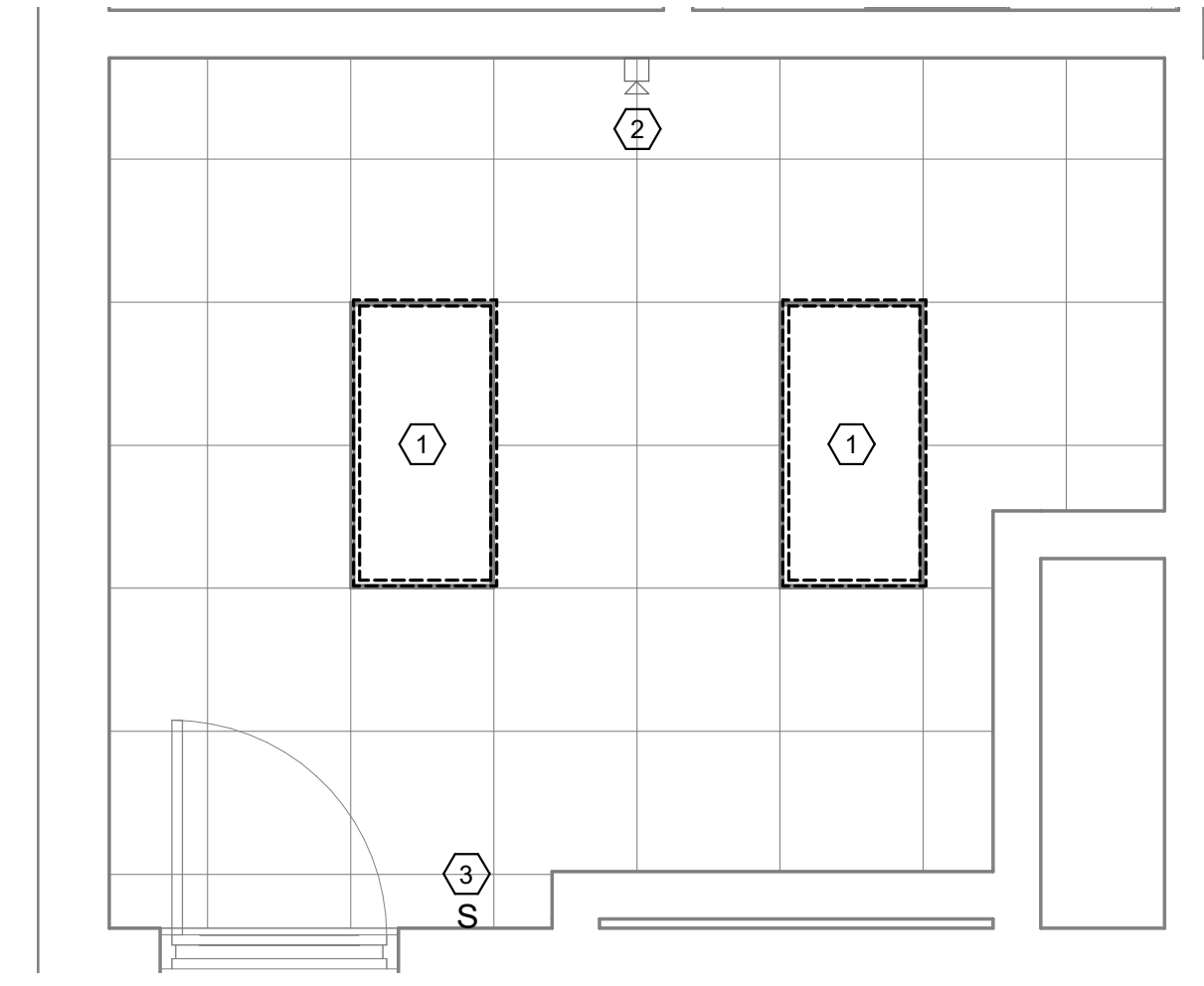

▲ **1** BOYS RESTROOM 208 - DEMOLITION RCP  
3/8" = 1'-0"

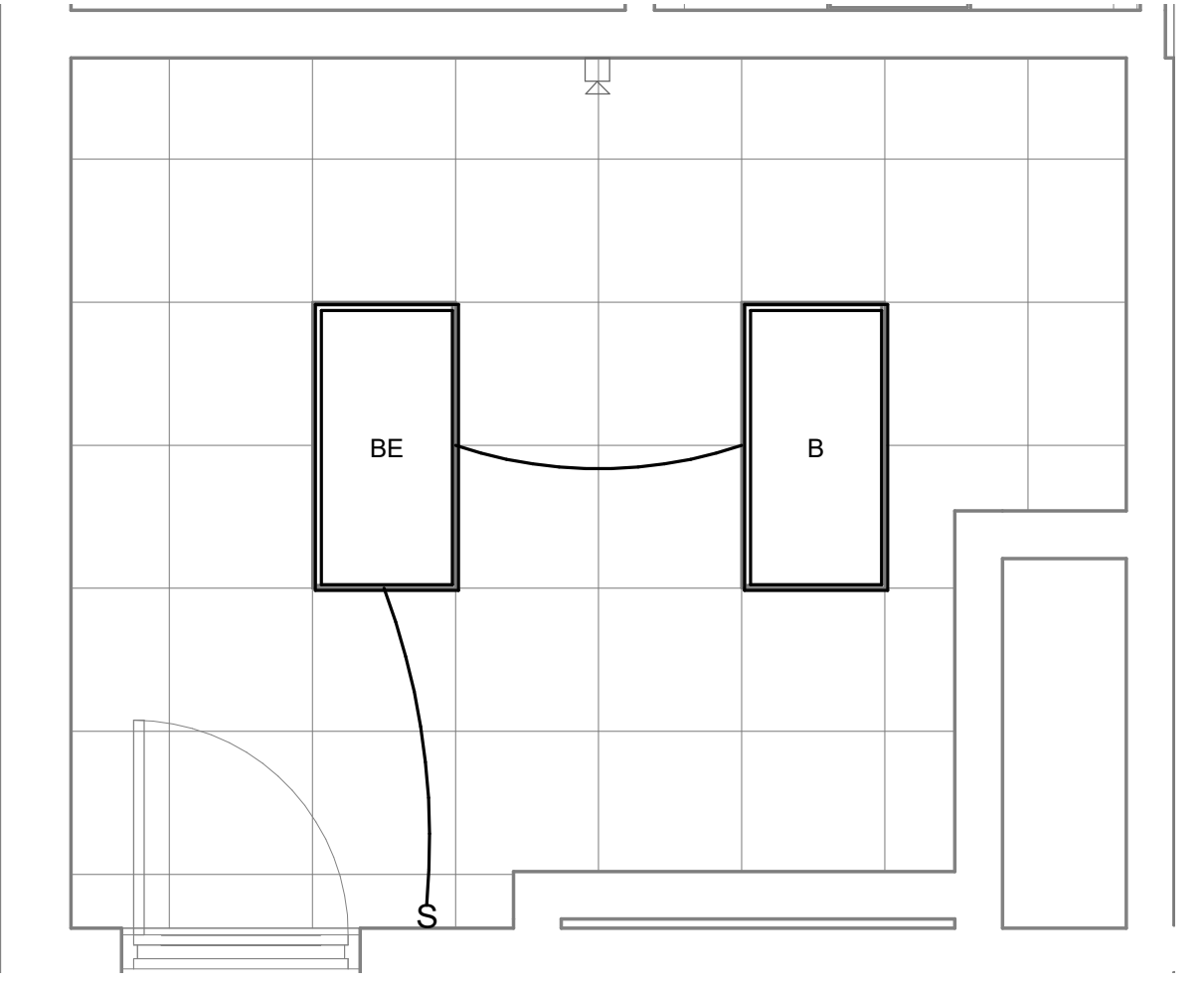

▲ **2** BOYS RESTROOM 208 - NEW CONSTRUCTION RCP  
3/8" = 1'-0"

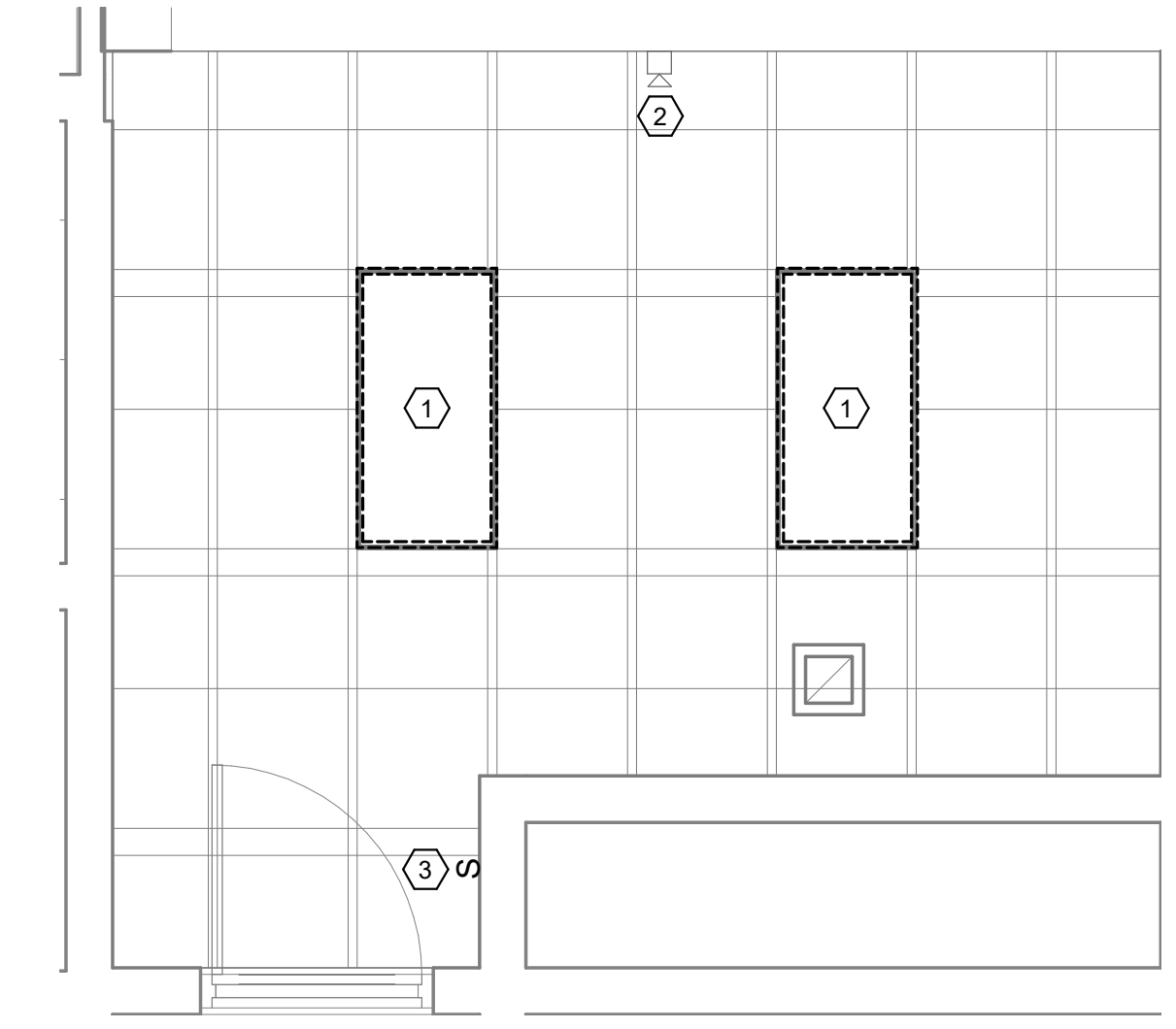

▲ **3** GIRLS RESTROOM 207 - DEMOLITION RCP  
3/8" = 1'-0"

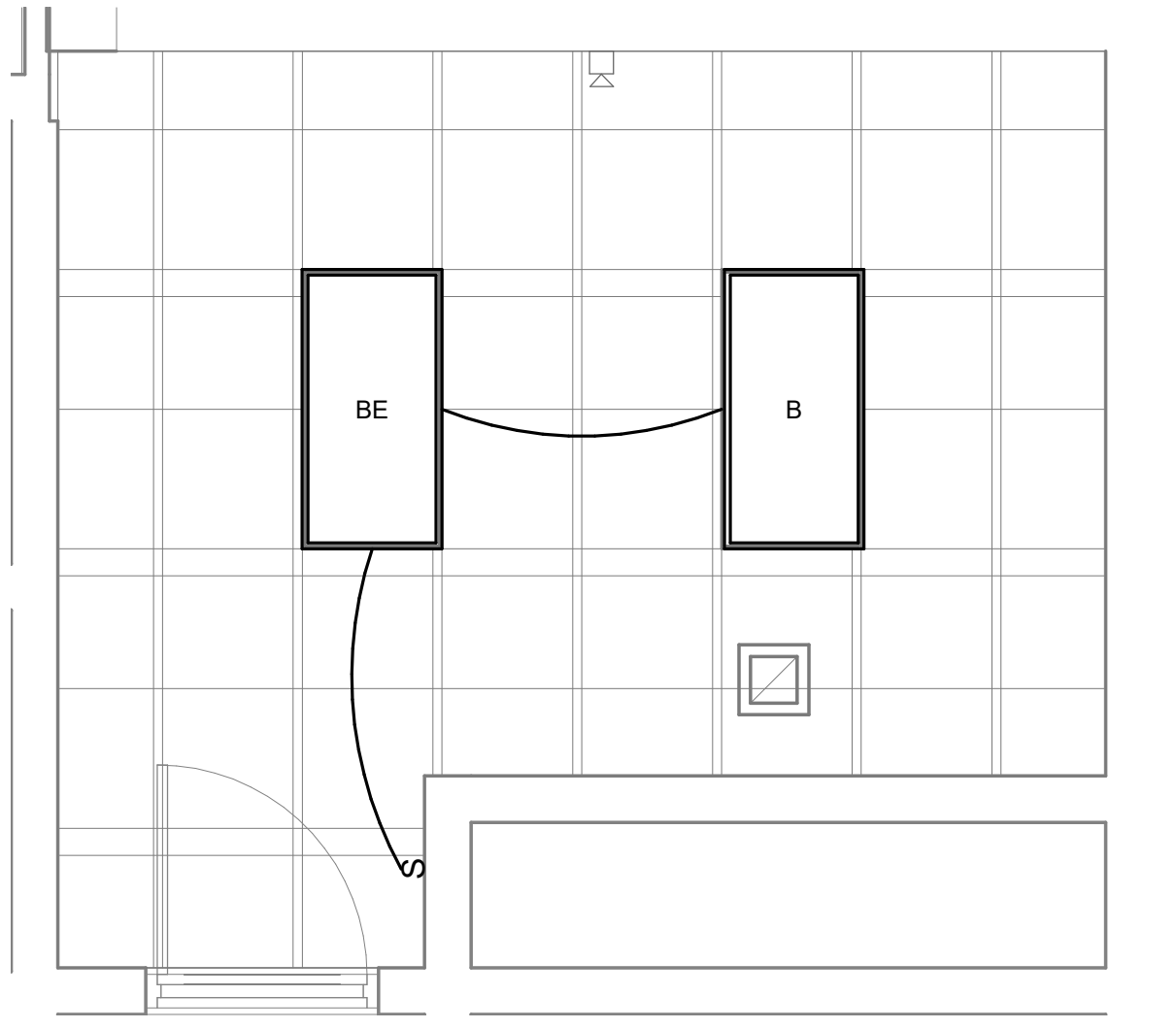

▲ **4** GIRLS RESTROOM 207 - NEW CONSTRUCTION RCP  
3/8" = 1'-0"

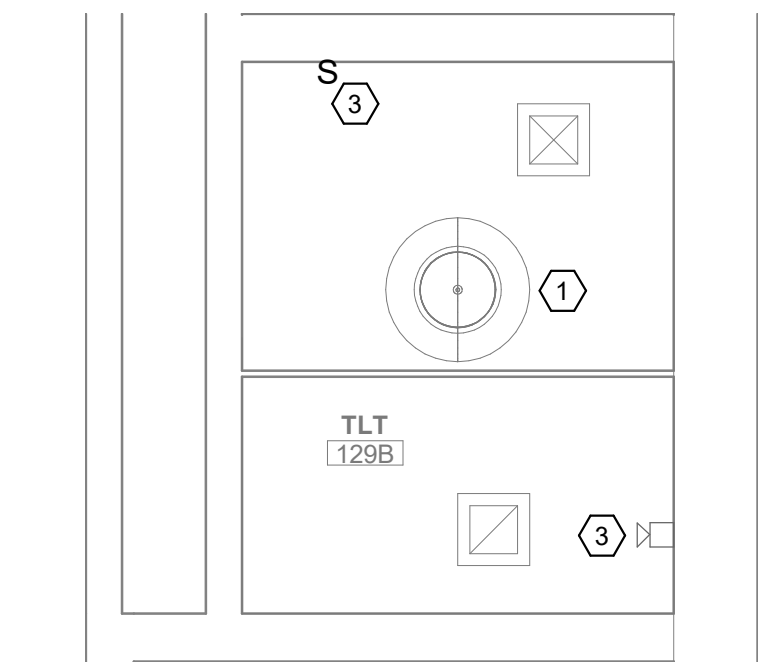

▲ **5** ART CLASSROOM TLT 140A - DEMOLITION RCP  
3/8" = 1'-0"

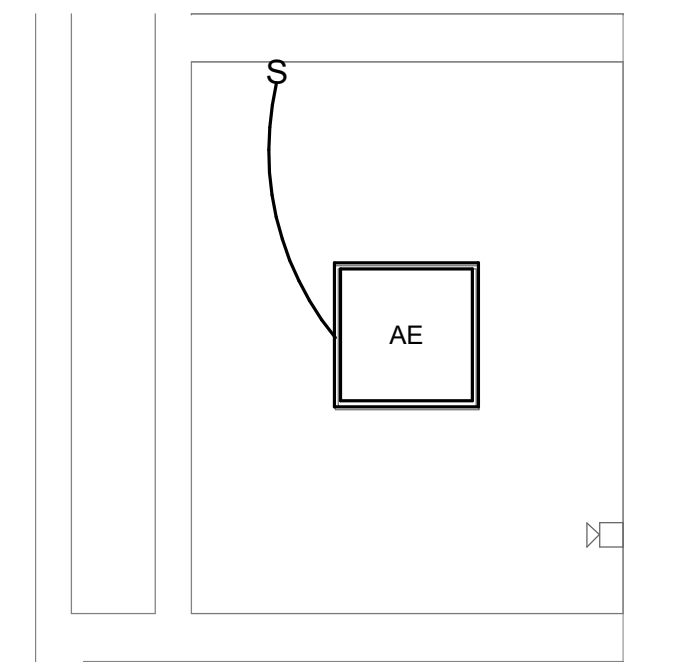

▲ **6** ART CLASSROOM TLT 140A - NEW CONSTRUCTION RCP  
3/8" = 1'-0"

PROJECT	
revisions	Date
No.	Description

project # **C22-0072**  
date **September 5, 2023**  
director

**ENLARGED ELECTRICAL PLANS**

**E8.00**