

**Delgado Community College
Purchasing Department
501 City Park Avenue, Bldg. 37
New Orleans, Louisiana 70119
(504) 762-3027**

Invitation to Bid

Bid Name:

R0026738 – Baseball Locker Room

Due by & to be opened on:

October 12, 2023 at 2:00PM CST

Contact Person:

Adrienne Harris

Assistant Director of Purchasing

(504) 762-3028

NAME OF COMPANY

ADDRESS

CITY, STATE, ZIP

PHONE NUMBER

FAX NUMBER

EMAIL

SIGNATURE OF COMPANY REPRESENTATIVE

NAME (PRINTED) & TITLE OF COMPANY REPRESENTATIVE

*** This form must be completed and submitted with your bid*

I. GENERAL INFORMATION

1. Any questions regarding this Invitation to Bid shall be in writing and shall be addressed to Adrienne Harris at the following address:

Delgado Community College
O'Keefe Administration Building
501 City Park Avenue, Building 37
New Orleans, La 70119
Email: aharri@dcc.edu
Fax: (504) 762-3089

Any additional information resulting from such inquiries shall be distributed to all bidders via addenda. The College will not be responsible for any other explanation of the documents.

Sealed bids may be submitted by mail or in person. Mailed bids and hand carried bids shall go to the address in item #1. Do not leave hand carried bids at the front desk. If bids are delivered via an express mail carrier, the bid name shall be on the outside of the packaging. Please note that express mail or USPS carriers may not deliver directly to 501 City Park Avenue. The bidder/proposer is solely responsible for ensuring that its courier service provider makes inside deliveries to 501 City Park Avenue.

3. Each bidder is solely responsible for the accuracy and completeness of its bid. Errors or omissions may be grounds for rejection, or may be interpreted in favor of the College.

4. Each bidder is solely responsible for the timely delivery of its bid. Delgado Community College will not be responsible for any delays in the delivery of bids, whether delayed in the mail, or for any reason whatsoever.

5. Only the issue of a purchase order or a signed acceptance of a proposal constitutes acceptance on the part of the College.

6. Assuming there is no prompt payment discount provision, payment will be made within 30 days from receipt of products in satisfactory condition, or within 30 days from receipt of invoice, whichever is later.

7. Proposer or bidder, contractor, etc. certifies, by signing and submitting a proposal for \$25,000 or more, that their company, any subcontractors, or principals are not suspended or debarred by the General Services Administration (GSA) in accordance with the requirements in OMB Circular A-133. (A list of parties who have been suspended or debarred can be viewed via the internet at www.epls.gov.)

II. BID FORM

R0026738 – Baseball Locker Room

SCOPE OF WORK:

The successful bidder shall provide and deliver the listed items to Delgado Community College, City Park Campus 615 City Park Avenue, New Orleans, LA 70119.

LIST OF ITEMS:

No.	Qty	UOM	Item & Model/Part No	Unit Price	Total Price	Delivery ETA
1)	42	EA	<p><u>Standard Materials and Design (NON LEED/NON FSC)</u></p> <p style="text-align: center;"><u>Players Lockers</u></p> <p>Athletic Team Locker - Straight Sides (84"H x 30"W x 24"D) 1-4"H Top Valance w/ 2" x 10" Name Plate Holder, 1 Top Shelf w/ Lock Box (Half Width w/ Zephyr Combination Lock and Lasered Logo and Legacy 110V/USB. 1-Bat Holder, 1-Coat Rod, 2-Coat Hooks, 1-Flip Lid Seat w/ Lid Stay and 5 Knuckle Hinges, 3-Vent Routes (Unfinished)</p> <p>** Bat Holder Routed and Edgebanded behind Lock Box Door</p>			
2)	42	EA	Legacy Forest Green Seat Cushion (No Logo)			
3)	2	EA	Master Keys for Lock			
4)	10	EA	Red Oak Slab Veneer Filler Panel (84"H X 12"W)			
5)	1	EA	Legacy 4" Base Package-Preassembled in Sections per Layout with Matching Trim			
6)	7	EA	<p><u>Standard Materials and Design (NON LEED/NON FSC)</u></p> <p style="text-align: center;"><u>Umpires and Coaches Lockers</u></p> <p>Athletic Team Locker(Straight Sides) 84"Hx18"Wx24D, 1-4"H Top Valance w/2" x 10" Name Plate Holder, 1 Top Shelf w/Lock Box (Half Width w/Zephyr Combination Lock, Lasered Logo and Legacy 110V/USB 1-Coat Rod, 2-Coat Hooks, 1-Flip Lid Seat w/Lid Stay and 5 Knuckle Hinges, 3-Vent Routes (Unfinished)</p>			
7)	7	EA	Legacy Forest Green Seat Cushion (No Logo)			
8)	14	EA	Red Oak Slab Veneer Single End Panel 84"Hx24"W			
9)	1	EA	Legacy 4" Base Package-Preassembled in Sections per Layout with Matching Trim			

No.	Qty	UOM	Item & Model/Part No	Unit Price	Total Price	Delivery ETA
10)	1	EA	Installation, set-up i.e. of the above equipment			

***Should be as specified ***

TOTAL BID AMOUNT OF ALL LINE ITEMS: _____

*NOTE: All shipping, handling, setup, or any other charges necessary for the provision and delivery of these goods and/or services must be included in your bid. The College will **not** pay for any charges invoiced other than the unit price as stated on the bid.*

By signing below, the Bidder agrees that he/she complies with all bid requirements, instructions, specifications, terms and conditions and special conditions as stated in the bid.

Signature _____

Title _____

Company _____

****Bid must be submitted on this form***

III. INSTRUCTIONS & REQUIREMENTS FOR BIDDERS

QUALIFICATIONS:

Vendors/Contractors Bidding this contract shall have at least ten (5) years of experience for the work, supplies, equipment and installation as requested. Delgado Community College reserves the right to make any inquiries and investigations it deems necessary to determine the capability and responsibility of any Bidder to perform the contract work. The Bidder shall furnish all information and data requested by the College for this purpose. Failure of any Bidder to promptly provide information with their bid or in connection with any inquiry may be grounds for rejection of their bid without further consideration.

PRE-BID/JOBSITE VISIT:

A **non-mandatory** site visit has been scheduled for this project. The site visit will be held at Delgado Community College City Park Campus meet in front of Kirsch-Rooney Stadium located at **5423 General Diaz Street, New Orleans LA 70124** on **Tuesday, October 3, 2023 at 1:00pm**. Please contact Tyler Scheuermann at 504-432-6206 **the day before if you would like to visit the site**. While it is not a requirement of the bid consideration to attend this site visit, it is strongly recommended that prospective bidders visit the jobsite to ascertain the scope of the work to be performed.

REFERENCES:

Bidder must complete **reference form** (*Attachment A*) and submit it with their bid. References should be from companies that the Bidder has provided a similar or larger scale operation based upon volume of products and type of service as required in the specifications.

ADDENDA:

Any questions arising from the specifications or the pre-bid conference must be addressed in writing to the individual indicated in Section I, General Information, and will be answered via an Addendum. All questions must be submitted no later than **Friday, October 6th, 2023 by 12:00PM CST**.

Any interpretation, correction or change of the Bidding Documents will be made by addendum. Interpretations, corrections or changes of the Bidding Documents made in any other manner will not be binding, and Bidders shall not rely upon such interpretations, corrections and changes. The Bidder must acknowledge all issued addenda in the space provided on the Bid Form. Failure to acknowledge addenda will render the bid informal and will cause its rejection.

Bid Documents and Addenda may be downloaded from:

<https://wwwcfprd.doa.louisiana.gov/osp/lapac/dspBid.cfm?search=department&term=39>

BID SUBMITTAL:

Bids must be sealed with the **Bidder's name, license number (if applicable) along with the name and number of the bid clearly written on the front of the envelope, including express mail packaging** and delivered to the person and location in Section I, General Information by the date and time stated on the title page. Bids received without this information or after the due date and time will be automatically disqualified.

Proposer is solely responsible for ensuring that its courier service provider makes inside deliveries to Delgado Community College physical location **directly** to the College's contact person in the **Purchasing Department by 2:00PM** no exceptions. Delgado Community College is not responsible for any delays caused by the Proposer's chosen means of proposal delivery. Proposer is solely responsible for the timely delivery of its proposal. Failure to meet the proposal opening date and time shall result in rejection of the proposal.

In accordance with R.S. 37:2163A, Contractors' License number in the appropriate classification(s) must appear on the bid envelope submitted on all projects in the amount of \$50,000 or more (and \$1.00 or more if hazardous materials are involved).

Bids must be submitted on the forms furnished for this purpose and must be filled out in ink or typewritten and signed in ink. Do not erase, correct, or write over any prices or figures necessary for this proposal. If any corrections are necessary, each must be initialed by bidder. Failure to comply with the above requirements will cause your bid to be disqualified.

Effective August 15, 1997, in accordance with L.R.S. 39:1594 (Act 121), the person signing the bid must be:

- a) A current corporate officer, partnership member or other individual specifically authorized to submit a bid as reflected in the appropriate records on file with the Secretary of State; or

- b) An individual authorized to bind the vendor as reflected by an accompanying corporate resolution, certificate, or affidavit.

By signing the bid, the bidder certifies compliance with the above.

MODIFICATION OR WITHDRAWAL OF BID:

A bid may not be modified, withdrawn, or canceled by the Bidder for a period of thirty (30) calendar days for the period following the time and bid date designated for the receipt of bids, and Bidder so agrees in submitting his bid, except in accordance with R.S. 39:1594,F.

Prior to the time and date designated for receipt of bids, bids submitted early may be modified or withdrawn only by notice to Delgado Community College Purchasing Office at the place and prior to the time designated for receipt of bids.

Withdrawn bids may be resubmitted up to the time designated for the receipt of bids provided that they are then fully in conformance with these Instructions to Bidders.

BIDDER REPRESENTATION:

By signing and submitting a bid, Bidder acknowledges that he/she has read and understands the Bidding Documents and the bid is made in accordance therewith.

The Bidder is advised to carefully consider all College physical features and activities and occupancies by faculty, staff and students, and to plan activities so as not to disrupt the normal operations and activities of the College except as expressly permitted by the College in writing.

The Bidder agrees that his/her bid is based solely upon the Bidding Documents as advertised and as modified by addenda. The bid submitted is not based on any verbal instructions contrary to the Bidding Documents and addenda.

END OF SECTION III

IV. TERMS AND CONDITIONS

GENERAL TERMS & CONDITIONS:

- A response to a bid invitation is our only indication of your interest in college business. Failure to respond to six (6) consecutive bid invitations may cause your name to be removed from the bidders' list.
- No information will be given out as to opinions concerning the ultimate outcome while consideration of the award is in progress.
- Effective September 1, 1991, in accordance with Act 1029 of the 1991 Regular Legislative Session, Delgado Community College will not be responsible for any sales tax, either state or local.
- Delgado Community College reserves the right to reject any and all bids and to waive any informality.
- It shall be distinctly agreed and understood that the price quoted must be a firm price, and not be subject to change at time of the shipment of goods or delivery of services.
- All shipping, handling, materials, labor or any other charges necessary to compete this job must be included in amount bid. Items not listed but necessary for completion of the job shall be furnished as part of the bid. Additional costs disclosed later will be at the expense of the vendor.
- All deliveries shall be made FOB Destination to the College unless otherwise specified by the College. All freight charges are to be included in the unit price. The College will not be responsible for freight charges not clearly stated as a part of this bid.
- The College reserves the right to award the above items separately, grouped, or on an all-or-none basis, and to reject any or all bids and to waive any informalities including technicalities in specifications that preclude competition.
- The College shall have the right to reject any or all bids not accompanied by any data required by the Bidding Documents or a bid in any way incomplete or irregular.
- The Bid will be awarded on the basis of the lowest total cost as determined by the College.
- List of distributors: The Vendor signing the bid shall be designated as the Prime Vendor on any contract/agreement resulting from this bid. If additional Vendors are authorized to receive orders for items covered under this proposal, the Vendor must submit, with bid, a list of those additional authorized distributors.
- If item(s) or services bid do not fully comply with specifications, including brand and/or product number or work, bidder must state in what respect the item(s)/services or work deviate. Failure to note exceptions on the bid form will not relieve the successful bidder from supplying the actual products or services requested.

CONTRACT TERM & AGREEMENT:

The Form of Agreement between the College and Contractor for the work set forth herein will be the issuance of a purchase order.

PAYMENTS:

Contractor will be paid after work is satisfactorily completed and upon recommendation of the College Representative. Payments for services shall be made on a Net 30 basis after the receipt of an invoice after completion of the work.

Invoices will not be paid prior to 30 days from receipt of invoice or completion of services/receipt of project.

All invoices should be submitted to the College's Office of Accounts Payable and clearly indicate the Purchase Order Number assigned by the Delgado Purchasing office. Invoices must be itemized in accordance with the fees set forth in the bid schedule.

INSURANCE:

Vendor compliance with the attached insurance and indemnification requirements is mandatory. A completed copy of the **indemnification agreement** (*Attachment A*) must be submitted with the bid. Failure to do so will result in immediate disqualification of the bid. Upon award, a certificate of insurance must be submitted to Delgado Community College, delineating Delgado Community College as the certificate holder prior to the commencement of any work. If a certificate is not received within 72 hours after notification of an award, the College reserves the right to disqualify the Bid as non-responsive and will move to award to the next low Bidder.

DELIVERABLES:

Time is of the essence and the College reserves the right to award to that Vendor providing the earliest Delivery date. The College also reserves the right to reject any Vendor who cannot make delivery within the timeframe specified in this bid.

Successful Bidder must be able to provide the materials within ten (10) weeks from the receipt of the purchase order.

TERMINATION OF AGREEMENT:

Termination of this agreement for cause – DCC may terminate this agreement for cause based upon the failure of Contractor to comply with the terms and/or conditions of the Agreement, or failure to fulfill its performance obligations pursuant to this agreement, provided that DCC shall give the Contractor written notice specifying the Contractor's failure. If within thirty (30) days after receipt of such notice, the Contractor shall not have corrected such failure or, in the case of failure which cannot be corrected in thirty (30) days, have begun in good faith to correct such failure and thereafter proceeded diligently to complete such correction, then DCC may, at its option, place the Contractor in default and the Agreement shall terminate on the date specified in such notice.

The Contractor may exercise any rights available to it under Louisiana law to terminate for cause upon the failure of DCC to comply with the terms and conditions of this agreement, provided that the Contractor shall give DCC written notice specifying the DCC's failure and a reasonable opportunity for DCC to cure the defect.

Termination for non-appropriation of funds - The continuance of this contract is contingent upon the appropriation of funds to fulfill the requirements of the contract by the legislature. If the legislature fails to appropriate sufficient monies to provide for the continuation of the contract, or if such appropriation is reduced by the veto of the Governor or by any means provided in the appropriations act or Title 39 of the Louisiana

Revised Statutes of 1950 to prevent the total appropriation for the year from exceeding revenues for that year, or for any other lawful purpose, and the effect of such reduction is to provide insufficient

monies for the continuation of the contract, the contract shall terminate on the date of the beginning of the first fiscal year for which funds are not appropriated.

Termination for Convenience - The College may terminate the Contract at any time by giving thirty (30) days written notice to the Contractor. The Contractor shall be entitled to payment for work performed (monthly charges to be prorated) to the extent work has been performed satisfactorily.

If, for any reason, the Contractor desires to terminate the Contract, he may do so upon giving written notice of sixty (60) days to the College. Contractor shall perform all work satisfactorily as contracted until the determined termination date.

DISCRIMINATORY PRACTICES:

Delgado Community College of the State of Louisiana is an equal opportunity employer and looks to its contractors, subcontractors, vendors, and suppliers to take affirmative action to effect this commitment in its operations.

Both the College and the bidder shall abide by the requirements of Title VII of the Civil Rights Act of 1964, and shall not discriminate against employees or applicants due to race, color, religion, sex, handicap or national origin. Furthermore, both parties shall take affirmative action to provide for positive posture in employing and upgrading persons without regard to race, color, religion, sex, handicap, or national origin, and shall take affirmative action as provided in the Vietnam Era Veteran's Readjustment Act of 1974.

Both parties shall abide by the requirements of Title VI of the Civil Rights Act of 1964 and the Vocational Rehabilitation Act of 1974 to ensure that services are delivered without discrimination due to race, color national origin or handicap. Both parties shall comply with the requirements of the Americans with Disabilities Act of 1990 which bans discrimination in employment or in delivery of services on the basis of sexual orientation.

SUBCONTRACTORS:

All subcontractors must be identified and approved in writing in advance by the College. Contractor shall promptly pay all laborers, materialmen, subcontractors and suppliers for work performed pursuant to this contract.

It is the Contractor's responsibility to ensure that his subcontractors are properly licensed and insured and adhere to all rules and responsibilities as outlined in the bid documents.

MATERIALS:

Materials used in the performance of this work must be of the highest quality and safety and must comply with the specifications provided in the solicitation. Contractor is responsible for any and all costs necessary to perform the work listed in the specifications.

END OF SECTION IV

V. INSURANCE REQUIREMENTS FOR VENDORS

The Contractor/Vendor shall purchase and maintain for the duration of the contract/work insurance against claims for injuries to persons or damages to property which may arise from or in connection with the performance of the work hereunder by the Contractor/Vendor, its agents, representatives, employees or subcontractors.

A. MINIMUM SCOPE AND LIMITS OF INSURANCE

1. Workers Compensation

Workers Compensation insurance shall be in compliance with the Workers Compensations law of the State of Louisiana. Employers Liability is included with a minimum limit of \$500,000 per accident/per disaster/per employee. If work is to be performed over water and involves maritime exposure, applicable LHWCA, Jones Act, or other maritime law coverage shall be included and the Employers Liability increased to a minimum of \$1,000,000.

2. Commercial General Liability

Commercial General Liability insurance, including Personal and Advertising Injury Liability, shall have a minimum limit per occurrence of \$1,000,000 and a minimum general aggregate of \$2,000,000. The Insurance Services office (ISO) Commercial General Liability occurrence coverage form CG 00 01 (current form approved for use in Louisiana), or equivalent, is to be used in the policy. Claims made form is unacceptable.

3. Automobile Liability

Automobile Liability Insurance shall have a minimum combined single limit per occurrence of \$1,000,000. ISO form number CA 00 01 (current form approved for use in Louisiana), or equivalent, is to be used in the policy. This insurance shall include third-party bodily injury and property damage liability for owned, hired and non-owned automobiles.

B. DEDUCTIBLES AND SELF-INSURED RETENTIONS

Any deductibles or self-insured retentions must be declared to and accepted by the Agency. The Contractor/Vendor shall be responsible for all deductibles and self-insured retentions.

C. OTHER INSURANCE PROVISIONS

The policies are to contain, or be endorsed to contain the following provisions:

1. General Liability and Automobile Liability Coverage's

- a. The Agency, its officers, agents, employees and volunteers shall be named as an additional insured as regards to negligence by the contractor/vendor. ISO Form CG 20 10 (current form approved for use on Louisiana), or equivalent, is to be used when applicable. The coverage shall contain no special limitations on the scope of protection to the Agency.

- b. The Contractor's/Vendor's insurance shall be primary as respects to the Agency, its officers, agents, employees and volunteers. Any insurance or self-insurance maintained by the Agency shall be excess and non-contributory of the Contractor's insurance.
- c. The Contractor's/Vendor's insurance shall apply separately to each insured against whom claim is made or suit brought, except with respect to the policy limits.

2. Workers Compensation and Employers Liability Coverage

The insurer shall agree to waive all rights of subrogation against the Agency, its officers, agents, employees and volunteers for losses arising from work performed by the Contractor for the Agency.

3. All Coverages

- a. Coverage/Vendor shall not be cancelled, suspended, or violated by either party (the Contractor/Vendor or the insurer) or reduced in coverage or in limits except after 30 days written notice has been given to the Agency. Ten-day written notice of cancellation is acceptable for non-payment of premium. Notifications shall comply with the standard cancellation provisions in the Contractor's/Vendor's policy.
- b. Neither the acceptance of the completed work nor the payment thereof shall release the Contractor/Vendor from the obligations of the insurance requirements or the indemnification agreement.
- c. The insurance companies issuing the policies shall have no recourse against the Agency for payment of premiums or for assessments under any form of the policies.
- d. Any failure of the Contractor/Vendor to comply with reporting provisions of the policy shall not affect coverage provided to the Agency, its officers, agents, employees and volunteers.

D. ACCEPTABILITY OF INSURERS

All required insurance shall be provided by a company or companies lawfully authorized to do business in the jurisdiction in which the Project is located. Insurance shall be placed with insurers with an A.M. Best's rating of **A-: VI or higher**. This rating requirement may be waived for workers compensations only.

If at any time an insurer issuing any such policy does not meet the minimum A.M Best rating, the Contractor/Vendor shall obtain a policy with an insurer that meets the A.M Best rating and shall submit another Certificate of Insurance as required in the contract.

E. VERIFICATION OF COVERAGE

Contractor/Vendor shall furnish the Agency with Certificates of Insurance reflecting proof of required coverage. The Certificates for each insurance policy are to be signed by a person authorized by that insurer to bind coverage on its behalf. The Certificates are to be received and approved by the Agency before work commences and upon any contract renewal thereafter.

In addition to the Certificates, Contractor/Vendor shall submit the declarations page and cancellation provision endorsement for each insurance policy. The Agency reserves the right to request complete certified copies of all required insurance policies at any time.

Upon failure of the Contractor/Vendor to furnish, deliver and maintain such insurance as above provided, this contract, at the election of the Agency, may be suspended, discontinued or terminated. Failure of the Contractor/Vendor to purchase and/or maintain any required insurance shall not relieve the Contractor/Vendor from any liability or indemnification under the contract.

F. SUBCONTRACTORS

Contractor/Vendor shall include all subcontractors as insured under its policies OR shall be responsible for verifying and maintaining the Certificates provided by each subcontractor. Subcontractors shall be subject to all of the requirements stated herein. The Agency reserves the right to request copies of subcontractor's Certificates at any time.

G. WORKERS COMPENSATION INDEMNITY

In the event the Contractor/Vendor is not required to provide or elects not to provide workers compensation coverage, the parties hereby agree that Contractor/Vendor, its owners, agents and employees will have no cause of action against, and it will not assert a claim against the State of Louisiana, its departments, agencies, agents and employer, whether pursuant to the Louisiana Workers Compensation Act, or otherwise under any circumstance. The parties also hereby agree that the State of Louisiana, its departments, agencies, agents, and employees shall in no circumstance be, or considered as, the employer or statutory employer of the Contractor/Vendor, its owners, agents and employees. The parties further agree that the Contractor/Vendor is a wholly independent contractor and is exclusively responsible for its employees, owners, and agents. Contractor/Vendor hereby agrees to protect, defend, indemnify and hold the State of Louisiana, its departments, agencies, agents and employees harmless from any such assertion or claim that may arise from the performance of this contract.

H. INDEMNIFICATION/HOLD HARMLESS AGREEMENT

Contractor/Vendor agrees to protect, defend, indemnify, save and hold harmless, the State of Louisiana, all State Departments, Agencies, Boards and Commissions, its officers, agents servants, employees and volunteers, from and against any and all claims, damages, expenses, and liability arising out of injury or death to any person or the damage, loss or destruction of any property which may occur, or in any way grow out of, any act or omission of the Contractor/Vendor, its agents, servants, and employees, or any and all costs, expenses and/or attorney fees incurred by the Contractor/Vendor as a result of any claims, demands, suits or causes of action, except those claims, demands suits, or causes of action arising out of the negligence of the State of Louisiana, all State Departments, Agencies, Boards, Commissions, its officers, agents, servants, employees and volunteers.

Contractor/Vendor agrees to investigate, handle, respond to, provide defense for and defend any such claims, demands, suits, or causes of action at its sole expense and agrees to bear all other costs and expenses related thereto, even if the claims, demands, suits, or causes of action are groundless, false or fraudulent.

END OF SECTION V

ATTACHMENT (A) – REFERENCES

_____	_____
(Company Name)	(Facility Type)
_____	_____
(Address)	(Phone Number)

(Contract Administrator)	

_____	_____
(Company Name)	(Facility Type)
_____	_____
(Address)	(Phone Number)

(Contract Administrator)	

_____	_____
(Company Name)	(Facility Type)
_____	_____
(Address)	(Phone Number)

(Contract Administrator)	

**** This Form must be completed and submitted with your bid**

END OF BID DOCUMENTS

ATTACHMENT B: INDEMNIFICATION AGREEMENT

_____ **{Contractor/Vendor/Lessee}** agrees to protect, defend, indemnify, save and hold harmless the State of Louisiana, all State departments, Agencies, Boards and Commissions, its officers, agents, servants, employees, and volunteers, from and against any and all claims, demands, expense and liability arising out of injury or death to any person or the damage, loss or destruction of any property which may occur or in any way grow out of any act or omission of

_____ **{Contractor/Vendor/Lessee}** its agents, servants, and employees, or any and all costs, expense and/or attorney fees incurred by

_____ **{Contractor/Vendor/Lessee}** as a result of any claims, demands, suits and/or causes of action except those claims, demands, suits and/or causes of action arising out of the negligence of the State of Louisiana, all State Departments, Agencies, Boards, Commissions, its officers, agents, servants, employees and volunteers.

_____ **{Contractors/Vendor/Lessee}** agrees to investigate, handle, respond to, provide defense for and defend any such claims, demands, suits, or causes of action at its sole expense and agrees to bear all other costs and expenses related thereto, even if the claims, demands, suites, or causes of action are groundless, false or fraudulent.

Accepted By:

Company Name

Signature

Title

Date Accepted

Is certificate of insurance attached? _____ YES _____ NO

• *This form must be completed and submitted with the bid*

**Delgado Baseball Locker Room
Locker Specifications
Section 10500 - Wood Lockers**

Part 1 – General

1.01 Section Includes

Provide wooden lockers, end panels and related items as specified.

1.01 Submittals

- A. Shop drawings showing individual locker construction, materials, dimensions, room layout, overall dimensions for installation and installation details including end and filler panels, crown molding, trim and accessories provided upon request.
- B. Stain and color chip samples for both wood and laminate doors are available upon request.

1.02 Product Handling

Store lockers and related products in a dry, climate controlled area in order to protect finished from damage during handling.

Part 2 – Products

2.01 Materials

- A. Furnish wooden lockers as manufactured by:
Legacy Lockers
- B. No Substitutions Allowed
- C. **Custom Locker Model: 43-0-86 IHC** (Players lockers include custom bat holder configuration and Legacy custom forest green seat cushion (no logo). Front face of flip lid seat to have 3 Legacy vent routes (unfinished). Umpires and Coaches lockers exclude the bat holder configuration. No Substitutions Allowed.
- D. Locker Body
 - a. Legacy Red Oak Slab Veneer: 3/4" A-1 plain sliced veneer on industrial grade particleboard core. 1 mm PVC edge banding to closely match stained face of panels.
 - b. Locking systems: Zephyr in-door combination lock standard on all lockers. Order to include two (2) master keys.
 - c. Hinges: Lock box doors have two (2) heavy duty, steel European concealed hinges with up to 130 degrees of door opening. Legacy Custom Flip Lid Seat to have Legacy standard 5 Knuckle Hinges.
 - d. Hardware: One (1) 4"H top valance w/ Legacy 2x10 name plate holder, one (1) top shelf w/ lock box (half width), one (1) Legacy 110V outlet/USB inside, and lock and custom logo laser engraved into door, one (1) coat rod, two (2) coat hooks, one (1) Legacy flip lid seat w/ Legacy lid stay. Coat rod, coat hooks and name plate holder available in polished chrome finish.
 - e. Number Disk: Not Applicable.
- E. Doors
 - a. Legacy Red Oak Slab Veneer: 3/4" A-1 plain sliced veneer on industrial

grade particleboard core. 1 mm PVC edge banding to closely match lock box door.

- b. Ends and Fillers: Locker end, filler and back panels to be of the same wood species and stain matching locker door. Delgado Baseball Locker Room Specs
- F. Finish: Custom UV Stain to Match WA #11067-38 Hemlock.

2.02 Fabrication:

Fabricate locker parts square and rigid without warp with the finished faces flat and free of scratches and chips.

Part 3 – Execution

3.01 Installation

- A. Install lockers and accessories per approved plans and manufacturer's instructions for a plumb, rigid and flush installation.
- B. Lockers to be installed on a 2"x4" or 2"x6" base per design drawing, supplied either by manufacturer or by owner according to contract. Base extending from the wall 2" less than the locker depth. All hardware and installation instructions are to be provided by manufacturer.
- C. Anchor lockers to wall studs or furring strips attached to wall through locker back and to the base through the locker floor. Attach lockers together through predrilled holes with manufacturer supplied connectors.
- D. Adjust doors and hinges to accommodate uniform spacing after installation of lockers. Verify all working parts of locker including hinge and lock function. Attach number disks in specified sequence. Clean lockers and deliver keys and pertinent information to appropriate individual.

Part 4 – Warranty

4.01

All wood parts and hardware shall be structurally sound and free from defects in material and workmanship under normal use and service for a period of three (3) years from date of delivery. All locking mechanisms are warranted for one (1) year.

Manufacturer reserves the right to modify, change or alter the design and/or specifications without prior notice.



Delgado Baseball Locker Room
Project Name:(Red Oak Option)

Engineer: D. Reedy
Date: 06/05/23



BASEBALL LOCKERS WITH GREEN CUSHIONS SHOWN



COACHES LOCKERS WITH GREEN CUSHIONS SHOWN

Delgado Baseball Locker Room
Project Name: (Red Oak Option) _____
Job Number: 43086 _____
Approved By: _____
Print Name: _____
Date: _____

LEGACY™
LOCKERS
4433 Bronze Way, Dallas, TX 75236
Ph: 866-937-1088 Fax: 214-466-1789
Engineer: D. Reedy
Date: 06/05/23
09/14/23



LEGACY™ LOCKERS

4433 Bronze Way, Dallas, TX 75236
Ph: 866-937-1088 Fax: 214-466-1789

Engineer: D. Reedy
Date: 06/05/23
09/14/23

Door Style:

Red Oak Slab Veneer (Plain Sliced)

Stain / Finish: Custom UV Stain

To Match WA 11067-38 Hemlock

Locker Interior:

Red Oak Slab Veneer (Plain Sliced)

Lock Type: Zephyr

Built In Combination (Master #717)

Edgeband:

Closest Match 1mm PVC

Hardware:

Polished Chrome

Project Numbering:

N/A

Base Provided By: Legacy

Base Height: 4"

**ALL LOCKERS 24" WIDE AND WIDER TO
BE CONSTRUCTED WITH BOTH
DOWELS AND SCREWS.**

Delgado Baseball Locker Room
Project Name:(Red Oak Option)

Job Number:43086

Approved By:_____

Print Name:_____

Date:_____

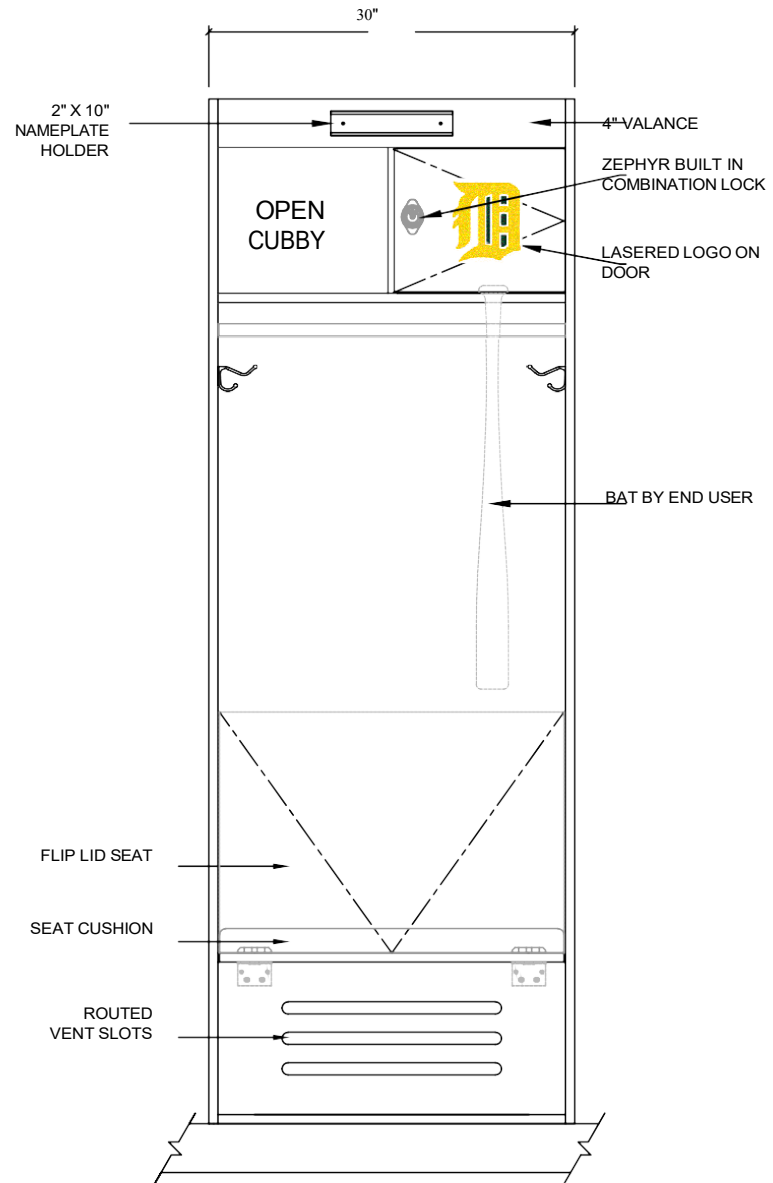

Front Elevation

MODEL: Athletic Team Locker
84" H X 30" W X 24" D
QTY: 42



LEGACY™ LOCKERS

4433 Bronze Way, Dallas, TX 75236
Ph: 866-937-1088 Fax: 214-466-1789

Engineer: D. Reedy
Date: 06/05/23
09/14/23

Door Style:
Red Oak Slab Veneer (Plain Sliced)
Stain / Finish: Custom UV Stain
To Match WA 11067-38 Hemlock

Locker Interior:
Red Oak Slab Veneer (Plain Sliced)
Lock Type: Zephyr
Built In Combination (Master #717)

Edgeband:
Closest Match 1mm PVC

Hardware:
Polished Chrome

Project Numbering:
N/A

Base Provided By: Legacy
Base Height: 4"

**ALL LOCKERS 24" WIDE AND WIDER TO
BE CONSTRUCTED WITH BOTH
DOWELS AND SCREWS.**

Delgado Baseball Locker Room
Project Name: (Red Oak Option)

Job Number: 43086

Approved By: _____

Print Name: _____

Date: _____

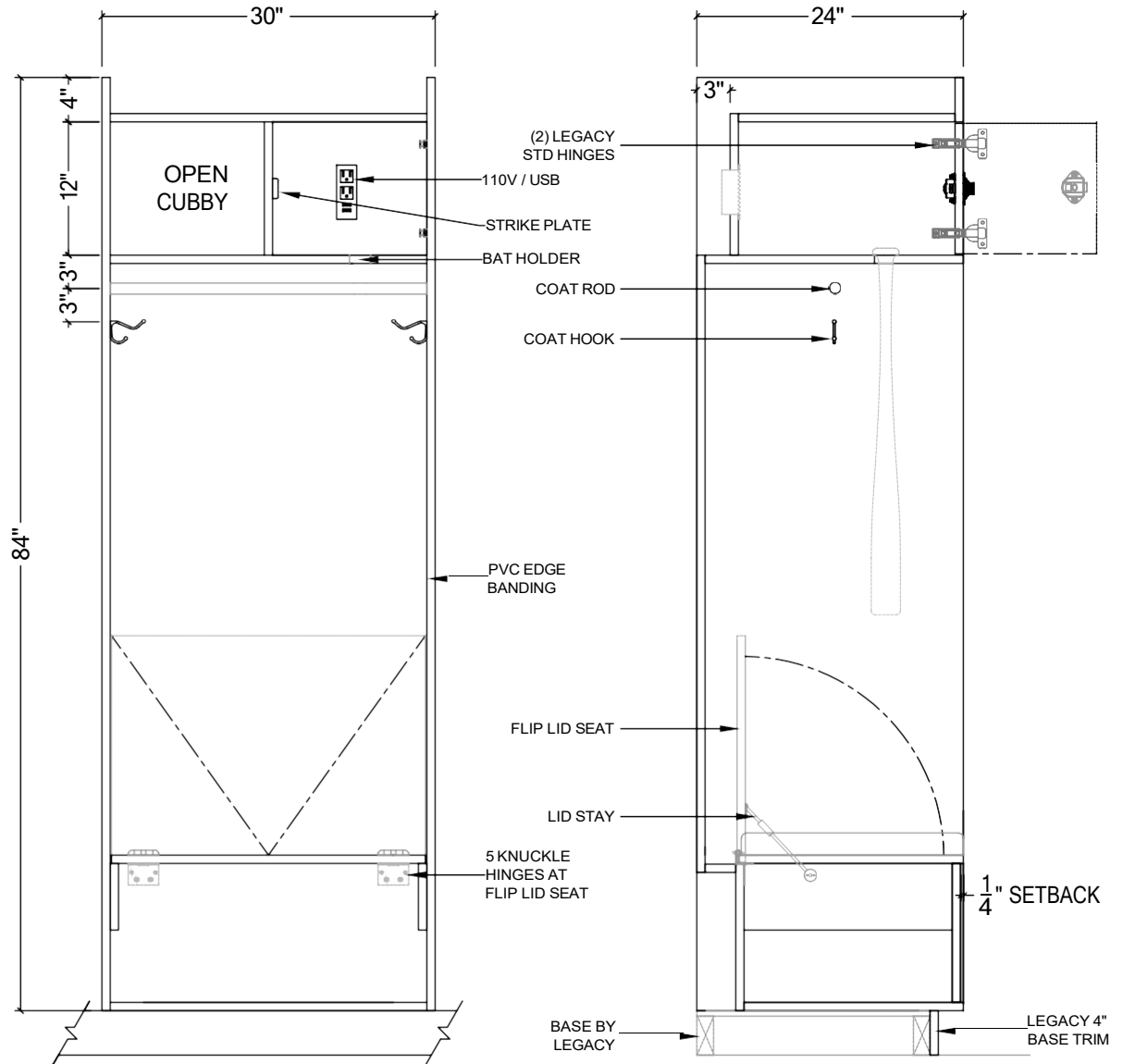

Interior Elevation

Side Elevation

MODEL: Athletic Team Locker
84" H X 30" W X 24" D
QTY: 42



LEGACY™ LOCKERS

4433 Bronze Way, Dallas, TX 75236
Ph: 866-937-1088 Fax: 214-466-1789

Engineer: D. Reedy
Date: 06/05/23
09/14/23

- Door Style:
Red Oak Slab Veneer (Plain Sliced)

- Stain / Finish: Custom UV Stain
To Match WA 11067-38 Hemlock

- Locker Interior:
Red Oak Slab Veneer (Plain Sliced)

- Lock Type: Zephyr
Built In Combination (Master #717)

- Edgeband:
Closest Match 1mm PVC

- Hardware:
Polished Chrome

- Project Numbering:
N/A

- Base Provided By: Legacy
Base Height: 4"

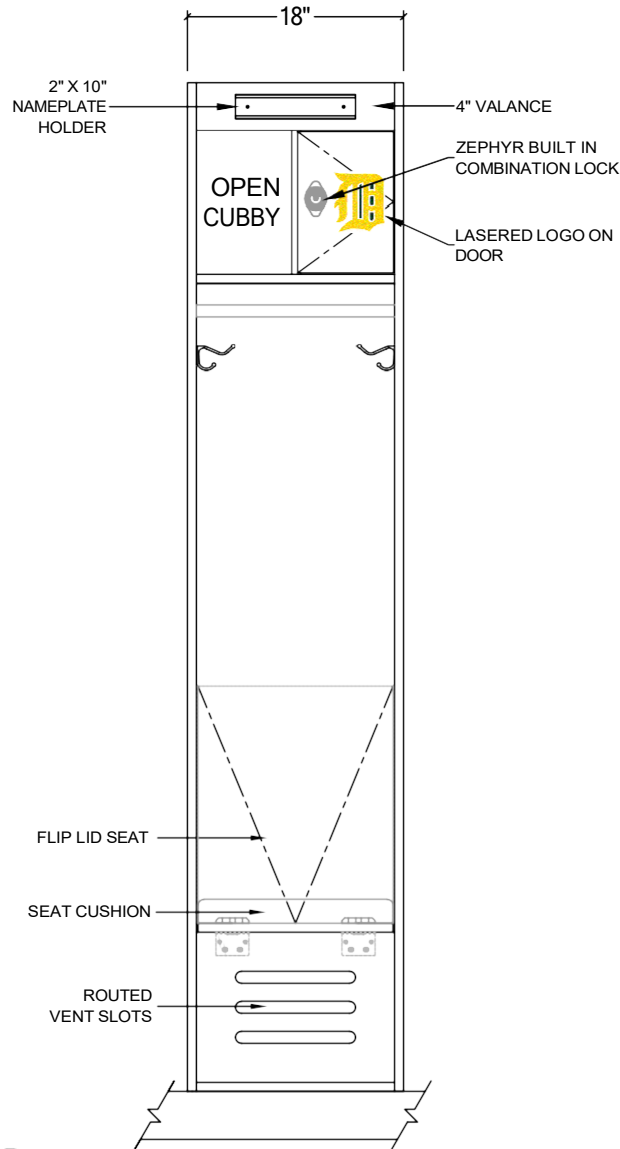

Front Elevation

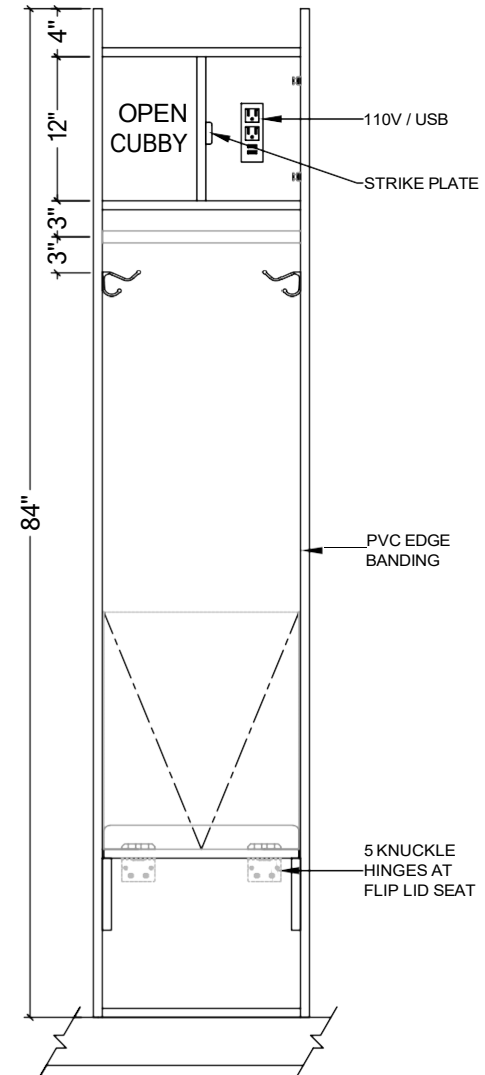

Interior Elevation

MODEL: Athletic Team Locker
84" H X 18" W X 24" D
QTY: 7

Delgado Baseball Locker Room
 Project Name: (Red Oak Option)
 Job Number: 43086
 Approved By: _____
 Print Name: _____
 Date: _____



LOCKERS

4433 Bronze Way, Dallas, TX 75236
Ph: 866-937-1088 Fax: 214-466-1789

Engineer: D. Reedy
Date: 06/05/23
09/14/23

- Door Style:
Red Oak Slab Veneer (Plain Sliced)

- Stain / Finish: Custom UV Stain
To Match WA 11067-38 Hemlock

- Locker Interior:
Red Oak Slab Veneer (Plain Sliced)

- Lock Type: Zephyr
Built In Combination (Master #717)

- Edgeband:
Closest Match 1mm PVC

- Hardware:
Polished Chrome

- Project Numbering:
N/A

- Base Provided By: Legacy
Base Height: 4"

Delgado Baseball Locker Room
 Project Name: (Red Oak Option) _____
 Job Number: 43086 _____
 Approved By: _____
 Print Name: _____

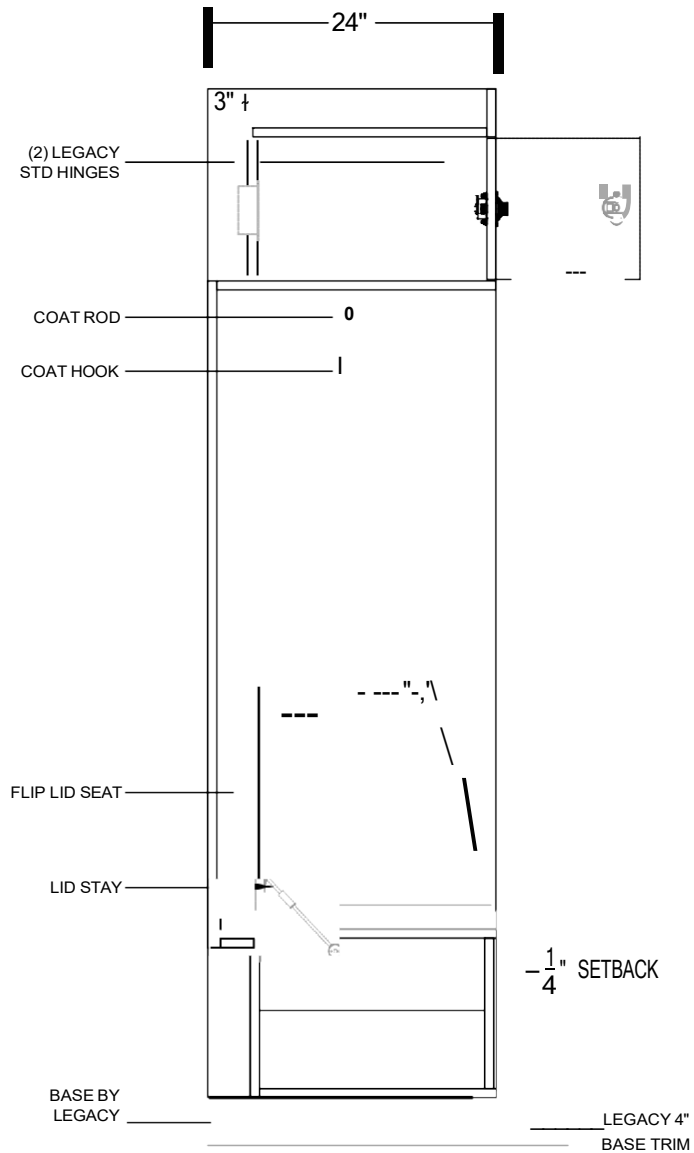

Side Elevation
 MODEL: Athletic Team Locker
 84"H X 18"W X 24"D
 QTY: 7

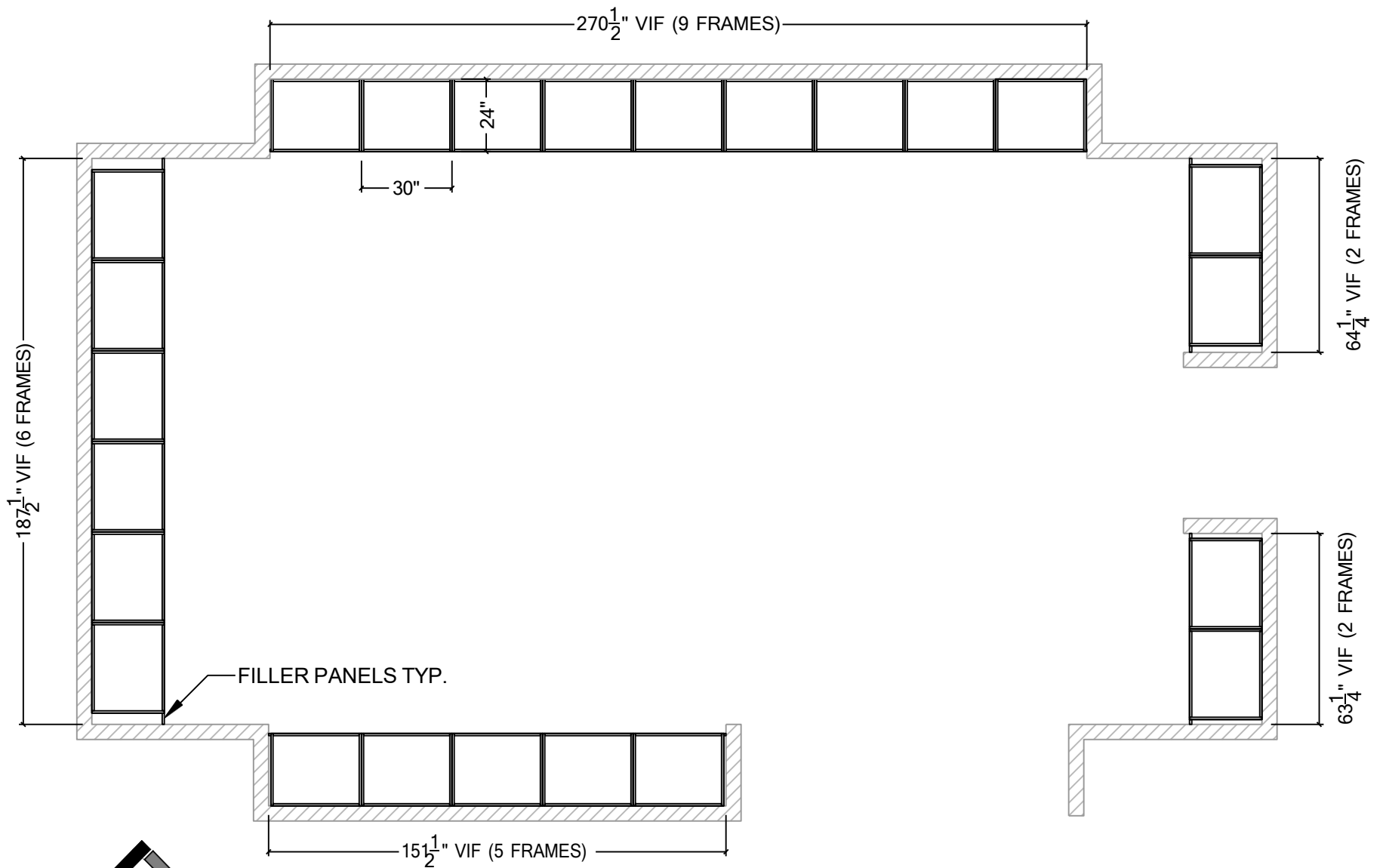

**LEGACY™
LOCKERS**

4433 Bronze Way, Dallas, TX 75236
Ph: 866-937-1088 Fax: 214-466-1789

Engineer: D. Reedy
Date: 06/05/23
09/14/23

Delgado Baseball Locker Room
Project Name: (Red Oak Option)

Job Number: 43086

Approved By: _____

Print Name: _____

Date: _____

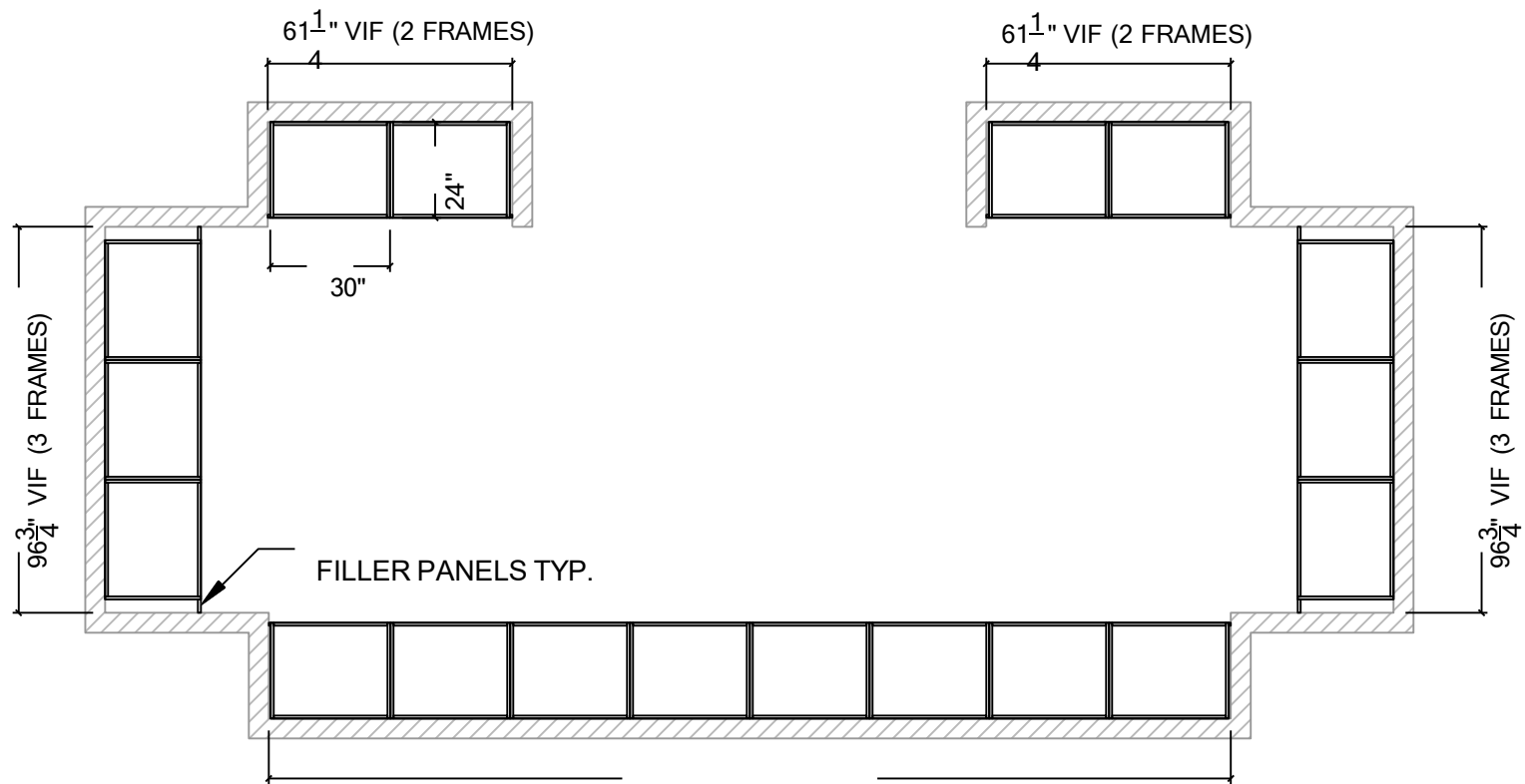

**LEGACY™
LOCKERS**

4433 Bronze Way, Dallas, TX 75236
Ph: 866-937-1088 Fax: 214-466-1789

Engineer: D. Reedy
Date: 06/05/23
09/14/23

Delgado Baseball Locker Room
Project Name: (Red Oak Option) _____

Job Number: 43086 _____

Approved By: _____

Print Name: _____

Date: _____