



24205 SOLICITATION TABLE OF CONTENTS

NIRC – BUILDING 30, 3RD FLOOR RENOVATION FOR (IT)

Table with 2 columns: Item Number and Page No.
1. BIDDER CERTIFICATION INFORMATION1
2. SCOPE OF WORK2
3. COMPLIANCE TO SCHEDULE/LIQUIDATED DAMAGES2
4. BID SECURITY REQUIREMENTS2
5. LOUISIANA CONTRACTORS LICENSE REQUIREMENTS2
6. BUSINESS HOURS3
7. SITE VISIT CONTACT INFORMATION3
8. PRE-BID MEETING INFORMATION3
9. DETAILED SPECIFICATIONS4
10. ALTERNATE(S)4
11. INSTRUCTIONS TO BIDDERS (Articles 1-9)6
12. SUPPLEMENTARY CONDITIONS (Articles 1-5, 7-15)13
13. INSURANCE REQUIREMENTS32
14. GENERAL REQUIREMENTS34
15. ELECTRONIC BID SUBMISSION GUIDELINES37
16. VENDOR CHECKLIST38
17. LOUISIANA UNIFORM PUBLIC WORK BID FORM39
18. ATTESTATIONS AFFIDAVIT FORM40
19. NON-COLLUSION AFFIDAVIT FORM42
20. SPECIFICATIONS.....ATTACHMENT A
21. DRAWINGS.....ATTACHMENT B

UNIVERSITY OF LOUISIANA AT LAFAYETTE
Lafayette, Louisiana

SOLICITATION FILE NO. 24205
TITLE: NIRC – BUILDING 30, 3RD FLOOR RENOVATION FOR (IT)
OPTIONAL PRE-BID MEETING (in person): Tuesday, October 3, 2023 9:00AM
BID SUBMISSION DEADLINE: Tuesday, October 24, 2023, 2:00PM
ZOOM BID OPENING: Tuesday, October 24, 2023, 3:00PM

PROPOSAL FOR FURNISHING ALL LABOR, MATERIALS, EQUIPMENT, TRANSPORTATION, SUPERVISION, PERMITS, ETC. NECESSARY FOR THE NIRC – BUILDING 30, 3RD FLOOR RENOVATION FOR (IT), LOCATED ON THE UL LAFAYETTE CAMPUS, IN NEW IBERIA, LOUISIANA.

BID DEADLINE

The Purchasing Office at the University of Louisiana at Lafayette will electronically receive proposals for this solicitation up to the above-mentioned date and time. Proposals will not be received after this specified hour and date. Bids will be publicly opened and read by a designated employee of the Purchasing Department.

This is a Competitive Sealed Bid. See Guidelines for Electronic Submission of Bids and Virtual Bid Openings in the following pages of this solicitation, which contains complete details for submitting bids. Further information can be found in the attached INSTRUCTIONS TO BIDDERS.

Bidders submitting bids in the amount of \$50,000.00 or more SHALL show their license number in the subject line of their electronic bid submission; bids not submitted in accordance with this requirement, SHALL be rejected and shall not be read.

Bid must be received by the due date and time in the Purchasing Office as per the instructions outlined in this solicitation. Bid must be submitted with the BID NUMBER IN THE SUBJECT LINE of the electronic submission. The public bid opening will take place on Tuesday, October 24, 2023 at 3:00PM on Zoom, which is available for viewing by registering at https://ullafayette.zoom.us/meeting/register/tJAKf-CgqTktHd34CF-yOYAX0n48NfGrpJ2

Meeting ID: 949 8987 2779 Passcode: 351007

All inquiries regarding this request shall be directed to the Director of Purchasing at (337) 482-9051 or purchasing@louisiana.edu.

Attached is the completed proposal of the firm listed below. The undersigned certifies that he/she (or they) has/have carefully examined the Instructions to Bidders, the General Conditions, and the Specifications hereto attached and made part herein, and agrees to comply with the instructions, conditions, and specifications, as covered by the attached papers. On the basis of the specifications, the undersigned proposes to furnish any or all items listed in the schedule of items hereto attached, upon which prices are requested, and at the price stated for each item.

Firm Name

Address

City, State, Zip Code

Telephone No. including area code

Louisiana Contractor's License Number

Signature [By signing this bid, bidder certifies compliance with La. R.S. 38:2212(A)(1)(c) or RS 38:2212(0)]

Name (Printed)

Title

Date

E-Mail

GENERAL SPECIFICATIONS

FURNISH ALL LABOR, MATERIALS, EQUIPMENT, TRANSPORTATION, SUPERVISION, PERMITS, ETC. NECESSARY FOR THE NIRC – BUILDING 30 3RD FLOOR RENOATION FOR (IT), LOCATED ON THE UL LAFAYETTE CAMPUS, IN NEW IBERIA, LOUISIANA, AS SHOWN ON THESE SPECIFICATIONS...

SCOPE OF WORK

1. Labor and material to install walls, doors, and ceilings.
2. Labor and material to install mechanical HVAC system including ductwork, insulation, and grilles.
3. Labor and material to install electrical lighting, and power from existing electrical panel provided and installed by owner.

COMPLIANCE TO SCHEDULE/LIQUIDATED DAMAGES

DUE TO THE IMPORTANCE OF THE SCHEDULE, LIQUIDATED DAMAGES IN THE AMOUNT OF ONE HUNDRED DOLLARS (\$100.00) PER DAY WILL BE ASSESSED FOR EVERY CALENDAR DAY THAT THIS PROJECT IS NOT COMPLETE BEYOND ONE HUNDRED EIGHTY (180) DAYS OF THE NOTICE TO PROCEED.

BID SECURITY REQUIREMENTS

Each bidder MUST accompany his/her proposal with a bid security for five percent (5%) of the total maximum amount of his/her bid. The bid security shall be drawn in favor of the University of Louisiana at Lafayette and SHALL be in the form of a Bid Bond (Insurance Company), Bank Money Order*, Certified Check* or Cashier's Check*. It shall become the property of the Owner in the event the contract and any performance bond are not executed within the time set forth. Bid bond shall be written by a surety or insurance company currently on the US Department of the Treasury Financial Management Service List of Approved Bonding Companies which is published annually in the Federal Register, or by a Louisiana domiciled insurance company with at least an "A"- Rating in the latest printing of the AM Best's Key Rating Guide to write individual bonds up to ten percent (10%) of policyholders' surplus as shown in the AM Best's Key Rating Guide.

Successful bidder WILL BE required to execute and deliver within ten (10) days of notification, a satisfactory performance bond and payment bond in the amount of one hundred percent (100%) of the contract price. Performance Bond, with Power of Attorney, shall be secured by a surety or insurance company currently on the US Department of the Treasury Financial Management Service List of Approved Bonding Companies, and in accordance with restrictions set by them or by an insurance company that is either domiciled in Louisiana or owned by Louisiana residents and is licensed to write surety bonds. In addition, any surety bond written for a public works Project shall be written by a surety or insurance company that is currently licensed to do business in the State of Louisiana. Also, to be provided at the same time is a Labor and Materials payment Bond in an amount equal to one hundred percent (100%) of the contract amount.

*Bid security in the form of a Bank Money Order, Certified Check or Cashier's Check shall be scanned and included with the bid submission (front and back) and the original must be mailed to and received no later than 3 business days after the bid opening.

University of Louisiana at Lafayette
Purchasing Office
PO Box 40197
Lafayette, LA 70504-0197

LOUISIANA CONTRACTORS LICENSE REQUIREMENTS

Contractors or contracting firms submitting bids in the amount of \$50,000.00 or more shall certify that they are licensed contractors under Chapter 24 of Title 37 of the Louisiana Revised Statutes 1950 and show their license number ~~on the front of the sealed envelope in which their bid is enclosed~~ in the subject line of the email submission. Bids shall be accepted from Contractors who are licensed under L.A. R.S. 37:2150-2163 in the following classification: **GENERAL BUILDING**

CONSTRUCTION. Bids in the amount of \$50,000.00 or more, not submitted in accordance with this requirement, shall be rejected and shall not be read. Additional information relative to licensing may be obtained from the Louisiana State Licensing Board for Contractors, Baton Rouge, Louisiana.

In accordance with La. R.S. 38:2227, LA. R.S. 38:2212.10 and LA. R.S. 23:1726(B) each bidder on this Project must submit a completed Attestations Affidavit (Past Criminal Convictions of Bidders, Verification of Employees and Certification Regarding Unpaid Workers Compensation Insurance) form found within this bid package. The Attestations Affidavit form shall be submitted to the Purchasing Department within 10 days **after** the opening of bids. **Affidavits submitted with the Bid**

Documents, prior to the opening of bids, will not be accepted in accordance with stated Revised Statute.

PROHIBITION OF DISCRIMINATORY BOYCOTTS OF ISRAEL

In accordance with LA R.S. 39:1602:1, for any contract for \$100,000 or more and for any contractor with five or more employees, Contractor, or any Subcontractor, shall certify it is not engaging in a boycott of Israel, and shall, for the duration of this contract, refrain from a boycott of Israel.

The State reserves the right to terminate this contract if the Contractor, or any Subcontractor, engages in a boycott of Israel during the term of the contract.

BUSINESS HOURS

Please send all correspondence electronically or through USPS. In-person delivery of document(s) will NOT be accepted. Business hours are Monday through Thursday, 7:30 am to 11:45 am, 12:30 pm to 5:00 pm, and Friday, 7:30 am to 12:30 pm. The Purchasing Office will be closed during Federal, State and University holidays. It is the responsibility of the prospective bidder to be aware of such closures.

Please note that courier services such as UPS, FedEx, and DHL will be **UNABLE to deliver to the Purchasing Office**. See *Guidelines for Electronic Submission of Bids and Virtual Bid Openings on page 4 of this solicitation for more detailed information*.

In providing this bid, each bidder represents that: They have read and understand the bid documents and the bid is made in accordance herewith, and the bid is based upon the specifications described in the bid documents without exception.

SITE VISIT/CONTACT INFORMATION

It is the responsibility of the prospective bidder to visit and examine jobsite, take measurements to his/her own satisfaction and determine conditions under which work is to be done. Owner will not accept responsibility for conditions which careful examination of premises would have shown existed.

To visit jobsite and for further information, prospective bidder is to contact Phillip J. Duplechin, 337-254-6868.

PRE-BID MEETING INFORMATION

A pre-bid meeting will be held at **9:00AM, Tuesday, October 3, 2023, at the Ackal Hall Auditorium, Building 34, 4401 West Admiral Doyle Dr, New Iberia, LA 70560**, at which time details of plans and specifications will be discussed.

TAX RELATED INFORMATION

It is the responsibility of the prospective bidder to pay taxes on materials purchased for this project. The University of Louisiana at Lafayette is a tax-exempt State Agency. However, that tax exempt status does not transfer to its contractors, subcontractors, suppliers, or vendors for their use.

For further information, prospective bidder should contact the Purchasing Department at purchasing@louisiana.edu, or call Mary Borel at 337-482-9051.

END OF SECTION

DETAILED SPECIFICATIONS

PROPOSAL FOR FURNISHING ALL LABOR, MATERIALS, EQUIPMENT, TRANSPORTATION, SUPERVISION, PERMITS, ETC. NECESSARY FOR THE NIRC – BUILDING 30 3RD FLOOR RENOVATION FOR (IT), LOCATED ON THE UL LAFAYETTE CAMPUS, IN NEW IBERIA, LOUISIANA, AS SHOWN ON THESE SPECIFICATIONS...

Base Bid

SCOPE OF WORK

1. Labor and material to install walls, doors, and ceilings.
2. Labor and material to install mechanical HVAC system including ductwork, insulation, and grilles.
3. Labor and material to install electrical lighting, and power from existing electrical panel provided and installed by owner.

SEE ATTACHMENT - A

END OF SECTION

BUILDING PLANS/DRAWINGS

Drawings and plans are included with this solicitation, and are provided to bidders as Attachment B.

END OF SECTION

ALTERNATES

Alternate No. 1 – N/A

Alternate No. 2 – N/A

Alternate No. 3 – N/A

END OF SECTION

Special Requirements Specific to the New Iberia Research Center

MEDICAL REQUIREMENTS

The Contractor shall have all on-site technicians/crew members provide proof of Measles immunization or positive Measles Titer to the Center representative prior to entering the Facility. The Contractor shall also supply proof of a negative TB test every 6 months for all on-site technicians/crew members for the duration of the Contract. Failure to supply appropriate medical documentation will restrict the technician(s)/crew member(s) from entry onto the Center premises until such time as the requirements are satisfactorily met. In addition, technicians/crew members shall be in overt good health with no signs of infectious disease to include fever, respiratory disease, gastrointestinal dysfunction or cold sores.

There will be no grace period for the performance of the medical requirements.

ENHANCED SECURITY CLEARANCE (CONTRACTORS):

The Contractor shall have all technicians/crew members submit to an Enhanced Security Clearance screening, prior to granting the individual access to the University of Louisiana at Lafayette's New Iberia Research Center's (NIRC) Facility. The screening of technicians/crew members will be conducted through Information Network Associates (INA), www.ina-inc.com and will be the sole responsibility of the New Iberia Research Center. The New Iberia Research Center will contact INA directly to request the "UL-NIRC Enhanced Security Clearance screening" be performed.

Eligibility for contracted employment with NIRC and access to the Facility, will be classified as a "Security Clearance", and will be granted only to those individuals whom have undergone the appropriate Enhanced Security Screening. Continued association with NIRC and access to the Facility is contingent upon maintaining a satisfactory Security Clearance.

A successful Security Clearance shall be considered a condition of the Contract. Any existing and/or new technician/crew member failing to satisfactorily pass the Enhanced Security Clearance will not be allowed to enter the Facility. The Contractor shall use its best efforts to assign technicians/crew members reasonably believed to be able to meet the Enhanced Security Clearance requirements.

There will be no grace period for the performance of the Enhanced Security Clearance screening.

GENERAL CLEAN-UP

The general Contractor shall be responsible for providing a dumpster and for the proper disposal of all work associated debris at an appropriate (for the type of debris), approved landfill.

The general Contractor shall be responsible for leaving the space, free of dust and mopped clean.

All surfaces shall be wiped down and free of dust.

END OF SECTION

INSTRUCTIONS TO BIDDERS

[https://www.doa.la.gov/.../24 Instructions to Bidders July2018.docx](https://www.doa.la.gov/.../24%20Instructions%20to%20Bidders%20July2018.docx)

ARTICLE 1

DEFINITIONS

- 1.1 The Bid Documents include the following:
- Advertisement for Bids (if applicable)
 - Instructions to Bidders
 - Bid Form
 - Bid Bond Instruction
 - General Conditions of the Contract for Construction, AIA Document A201, 2017 Edition
 - Supplementary Conditions
 - Contract Between Owner and Contractor and Performance and Payment Bond
 - Mandatory Affidavits
 - User Agency Documents (if applicable)
 - Change Order Form (if applicable)
 - Partial Occupancy Form (if applicable)
 - Recommendation of Acceptance (if applicable)
 - Asbestos Abatement (if applicable)
 - Other Documents (if applicable)
 - Specifications & Drawings
 - Addenda issued during the bid period and acknowledged on the Bid Form (if applicable)
- 1.2 All definitions set forth in the General Conditions of the Contract for Construction, AIA Document A201 and the Supplementary Conditions are applicable to the Bid Documents.
- 1.3 Addenda are written and/or graphic instruments issued by the Architect or Purchasing Office prior to the opening of bids, which modify or interpret the Bid Documents by additions, deletions, clarifications, corrections and prior approvals.
- 1.4 A bid is a complete and properly signed proposal to do the work or designated portion thereof for the sums stipulated therein supported by data called for by the Bid Documents.
- 1.5 Base bid is the sum stated in the bid for which the Bidder offers to perform the work described as the base, to which work may be added, or deleted for sums stated in alternate bids.
- 1.6 An alternate bid (or alternate) is an amount stated in the bid to be added to the amount of the base bid if the corresponding change in Project scope or materials or methods of construction described in the Bid Documents is accepted.
- 1.7 A Bidder is one who submits a bid for a prime Contract with the Owner for the work described in the Bid Documents.
- 1.8 A Sub-bidder is one who submits a bid to a Bidder for materials and/or labor for a portion of the work.
- 1.9 Where the word "Architect" is used in any of the documents, it shall refer to the Prime Designer of the Project, regardless of discipline.

ARTICLE 2

PRE-BID CONFERENCE

- 2.1 A Pre-Bid Conference shall be held at least 10 days before the date for receipt for bids. The Architect shall coordinate the setting of the date, time and place for the Pre-Bid Conference with the User Agency and shall notify in writing the

Owner and all who have received sets of the Bid Documents to attend. The purpose of the Pre-Bid Conference is to familiarize Bidders with the requirements of the Project and the intent of the Bid Documents, and to receive comments and information from interested Bidders. If the Pre-Bid Conference is stated in the Advertisement for Bids to be a Mandatory Pre-Bid Conference, bids shall be accepted only from those bidders who attend the Pre-Bid Conference. Contractors who are not in attendance for the entire Pre-Bid Conference will be considered to have not attended.

- 2.2 Any revision of the Bid Documents made as a result of the Pre-Bid Conference shall not be valid unless included in an addendum.

ARTICLE 3

BIDDER'S REPRESENTATION

- 3.1 Each Bidder by making his bid represents that:

- 3.1.1 He has read and understands the Bid Documents and his bid is made in accordance therewith.
- 3.1.2 He has visited the site and has familiarized himself with the local conditions under which the work is to be performed.
- 3.1.3 His bid is based solely upon the materials, systems and equipment described in the Bid Documents as advertised and as modified by addenda.
- 3.1.4 His bid is not based on any verbal instructions contrary to the Bid Documents and addenda.
- 3.1.5 He is familiar with Code of Governmental Ethics requirement that prohibits public servants and/or their immediate family members from bidding on or entering into contracts; he is aware that the Designer and its principal owners are considered Public Servants under the Code of Governmental Ethics for the limited purposes and scope of the Design Contract with the State on this Project (see Ethics Board Advisory Opinion, No. 2009-378 and 2010-128); and neither he nor any principal of the Bidder with a controlling interest therein has an immediate family relationship with the Designer or any principal within the Designer's firm (see La. R.S. 42:1113). Any Bidder submitting a bid in violation of this clause shall be disqualified and any contract entered into in violation of this clause shall be null and void.

- 3.2 The Bidder must be fully qualified under any State or local licensing law for Contractors in effect at the time and at the location of the work before submitting his bid. In the State of Louisiana, Revised Statutes 37:2150, et seq. will be considered, if applicable.

The Contractor shall be responsible for determining that all of his Sub-bidders or prospective Subcontractors are duly licensed in accordance with law.

ARTICLE 4

BID DOCUMENTS

- 4.1 Copies

- 4.1.1 Bid Documents may be obtained from the Architect for a deposit as stated in the Advertisement for Bids. The deposit will be refunded as stated in the Advertisement for Bids. No deposits will be refunded on Bid Documents returned later than ten days after receipt of bids.

- 4.1.1.2 As an alternative method of distribution, the Designer may provide the Bid Documents in electronic format. They may be obtained without charge and without deposit as stated in the Advertisement for Bids.

- 4.1.1.2.1 If electronic distribution is available, printed copies will not be available from the Designer, but arrangements can be made to obtain them through most reprographic firms and/or plan rooms.
- 4.1.1.2.2 If electronic distribution is available, the reproduction cost on the first paper plan set acquired by bona fide prime bidders will be fully refunded by the Designer upon

delivery of the documents to the Designer in good condition no later than ten days after receipt of bids.

- 4.1.1.2.3 If electronic distribution is available, all other plan holders are responsible for their own reproduction costs.

4.1.2 Complete sets of Bid Documents shall be used in preparing bids; neither the Owner nor the Architect assume any responsibility for errors or misinterpretations resulting from the use of incomplete sets of Bid Documents.

4.1.3 The Owner or Architect in making copies of the Bid Documents available on the above terms, do so only for the purpose of obtaining bids on the work and do not confer a license or grant for any other use.

4.2 Interpretation or Correction of Bid Documents

4.2.1 Bidders shall promptly notify the Architect of any ambiguity, inconsistency or error which they may discover upon examination of the Bid Documents or of the site and local conditions.

4.2.2 Bidders requiring clarification or interpretation of the Bid Documents shall make a written request to the Architect, to reach him at least seven days prior to the date for receipt of bids.

4.2.3 Any interpretation, correction or change of the Bid Documents will be made by addendum. Interpretations, corrections or changes of the Bid Documents made in any other manner will not be binding and Bidders shall not rely upon such interpretations, corrections and changes.

4.3 Substitutions

4.3.1 The materials, products and equipment described in the Bid Documents establish a standard of required function, dimension, appearance, and quality to be met by any proposed substitution. No substitutions shall be allowed after bids are received.

4.3.2 No substitution will be considered unless written request for approval has been submitted by the Proposer and has been received by the Architect at least seven (7) working days prior to the opening of bids. (La. R.S. 38:2295(C)) Each such request shall include the name of the material or equipment for which it is to be substituted and a complete description of the proposed substitute including model numbers, drawings, cuts, performance and test data and any other information necessary for an evaluation. A statement setting forth any changes in other materials, equipment or work that incorporation of the substitute would require shall be included. It shall be the responsibility of the proposer to include in his proposal all changes required of the Bid Documents if the proposed product is used. Prior approval, if given, is contingent upon supplier being responsible for any costs which may be necessary to modify the space or facilities needed to accommodate the materials and equipment approved.

4.3.3 If the Architect approves any proposed substitution, such approval shall be set forth in an addendum. Bidders shall not rely upon approvals made in any other manner.

4.4 Addenda

4.4.1 Addenda will be transmitted to all who are known by the Architect to have received a complete set of Bid Documents.

4.4.2 Copies of addenda will be made available for inspection wherever Bid Documents are on file for that purpose.

4.4.3 Except as described herein, addenda shall not be issued within a period of seventy-two (72) hours prior to the advertised time for the opening of bids, excluding Saturdays, Sundays, and any other legal holidays. If the necessity arises of issuing an addendum modifying plans and specifications within the seventy-two (72) hour period prior to the advertised time for the opening of bids, then the opening of bids shall be extended at least seven but no more than twenty-one (21) working days, without the requirement of re-advertising. UL Lafayette Purchasing shall be consulted prior to issuance of such an addendum and shall approve such issuance. The

revised time and date for the opening of bids shall be stated in the addendum.

- 4.4.4 Each Bidder shall ascertain from the Architect prior to submitting his bid that he has received all addenda issued, and he shall acknowledge their receipt on the Bid Form.
- 4.4.5 The Owner shall have the right to extend the bid date by up to (30) thirty days without the requirement of re-advertising. Any such extension shall be made by addendum issued.

ARTICLE 5

BID PROCEDURE

5.1 Form and Style of Bids

- 5.1.1 Bids shall be submitted on the Louisiana Uniform Public Work Bid Form provided by the Architect for this Project.
- 5.1.2 The Bidder shall ensure that all applicable blanks on the bid form are completely and accurately filled in.
- 5.1.3 Bid sums shall be expressed in both words and figures, and in case of discrepancy between the two, the written words shall govern.
- 5.1.4 Any interlineation, alteration or erasure must be initialed by the signer of the bid or his authorized representative.
- 5.1.5 Bidders are cautioned to complete all alternates should such be required on the Bid Form. Failure to submit alternate prices will render the bid non responsive and shall cause its rejection.
- 5.1.6 Bidders are cautioned to complete all unit prices should such be required in the Bid Form. Unit prices represent a price proposal to do a specified quantity and quality of work. Unit prices are incorporated into the base bid or alternates, as indicated on the Unit Price Form, but are not the sole components thereof.
- 5.1.7 Bidder shall make no additional stipulations on the Bid Form nor qualify his bid in any other manner.
- 5.1.8 Written evidence of the authority of the person signing the bid for the public work shall be submitted in accordance with La. R.S. 38:2212 (B)(5).
- 5.1.9 On any bid in excess of fifty thousand dollars (\$50,000.00), the Contractor shall certify that he is licensed under La. R.S. 37: 2150-2173 and show his license number on the bid above his signature or his duly authorized representative.

5.2 Bid Security

- 5.2.1 No bid shall be considered or accepted unless the bid is accompanied by bid security in an amount of five percent (5.0%) of the base bid and all alternates.

The bid security shall be in the form of a certified check, cashier's check drawn on a bank insured by the Federal Deposit Insurance Corporation, or a Bid Bond written by a surety company licensed to do business in Louisiana and signed by the surety's agent or attorney-in-fact. The surety for the bond must meet the qualifications stated thereon. The Bid Bond shall include the legal name of the bidder be in favor of the University of Louisiana at Lafayette, and shall be accompanied by appropriate power of attorney. The Bid Bond must be signed by both the bidder/principal. Failure by the bidder/principal or the surety to sign the bid bond shall result in the rejection of the bid.

Bid security furnished by the Contractor shall guarantee that the Contractor will, if awarded the work according to the terms of his proposal, enter into the Contract and furnish Performance and Payment Bonds as required by these Bid Documents, within fifteen (15) days after written notice that the instrument is ready for his signature.

Should the Bidder refuse to enter into such Contract or fail to furnish such bonds, the amount of the bid security

shall be forfeited to the Owner as liquidated damages, not as penalty.

- 5.2.2 The Owner will have the right to retain the bid security of Bidders until either (a) the Contract has been executed and bonds have been furnished, or (b) the specified time has elapsed so that bids may be withdrawn, or (c) all bids have been rejected.

5.3 Submission of Bids

See Guidelines for Electronic Submission of Bids and Virtual Bid Openings included in this solicitation.

- 5.3.1 ~~The Bid shall be sealed in an opaque envelope. The bid envelope shall be identified on the outside the name, address, and license number of the Bidder.~~

~~The envelope shall not contain multiple bid forms, and will be received until the time specified and at the place specified in the Advertisement for Bids. It shall be the specific responsibility of the Bidder to deliver his sealed bid to The University at the appointed place and prior to the announced time for the opening of bids. Late delivery of a bid for any reason, including late delivery by United States Mail, or express delivery, shall disqualify the bid.~~

~~If the bid is sent by mail, the sealed envelope shall be enclosed in a separate mailing envelope with the notation "Bid Enclosed" on the face thereof. Such bids shall be sent by Registered or Certified Mail, Return Receipt Requested, addressed to:~~

~~University of Louisiana at Lafayette
Purchasing Department,
P. O. Box 40197
Lafayette, LA 70504~~

~~Bids sent by express delivery shall be delivered to:~~

~~— University of Louisiana at Lafayette —
— Purchasing Department
Martin Hall, Room 123
104 University Circle
Lafayette, LA 70503~~

IMPORTANT: BIDS WILL NOT BE ACCEPTED BY U.S. MAIL OR IN-PERSON DELIVERY TO THE PURCHASING OFFICE. ANY REFERENCE TO SEALED ENVELOPES AND OR MAILED DOCUMENTS ARE TO BE DISREGARDED BY POTENTIAL BIDDERS. COURIER SERVICES SUCH AS UPS, FedEx, and DHL WIL NOT BE ABLE TO DELIVERY TO OUR PHYSICAL LOCATION AND THE BUILDING MAY BE LOCKED OR UNSTAFFED.

- 5.3.2 Bids shall be deposited at the designated location prior to the time on the date for receipt of bids indicated in the Advertisement for Bids, or any extension thereof made by addendum. Bids received after the time and date for receipt of bids will be returned unopened.

5.3.3 Bidder shall assume full responsibility for timely delivery at location designated for receipt of bids.

- 5.3.4 Oral, telephonic or telegraphic bids are invalid and shall not receive consideration. Owner shall not consider notations written on outside of bid form ~~envelope~~ which have the effect of amending the bid. Written modifications enclosed in the bid ~~envelope~~, and signed or initialed by the Contractor or his representative, shall be accepted.

5.4 Modification or Withdrawal of Bid

- 5.4.1 A bid may not be modified, withdrawn or canceled by the Bidder during the time stipulated in the Advertisement for Bids, for the period following the time and bid date designated for the receipt of bids, and Bidder so agrees in submitting his bid, except in accordance with R.S. 38:2214 which states, in part, "Bids containing patently obvious, unintentional, and substantial mechanical, clerical, or mathematical errors, or

errors of unintentional omission of a substantial quantity of work, labor, material, or services made directly in the compilation of the bid, may be withdrawn by the contractor if clear and convincing sworn, written evidence of such errors is furnished to the public entity within forty- eight hours of the bid opening excluding Saturdays, Sundays, and legal holidays".

- 5.4.2 Prior to the time and date designated for receipt of bids, bids submitted early may be modified or withdrawn only by notice to the party receiving bids at the place and prior to the time designated for receipt of bids.
- 5.4.3 Withdrawn bids may be resubmitted up to the time designated for the receipt of bids provided that they are then fully in conformance with these Instructions to Bidders.
- 5.4.4 Bid Security shall be in an amount sufficient for the bid as modified or resubmitted.

5.5 Prohibition of Discriminatory Boycotts of Israel

By submitting a bid, the bidder certifies and agrees that the following information is correct:

In preparing its bid, the bidder has considered all proposals submitted from qualified, potential subcontractors and suppliers, and has not, in the solicitation, selection, or commercial treatment of any subcontractor or supplier, refused to transact or terminated business activities, or taken other actions intended to limit commercial relations, with a person or entity that is engaging in commercial transactions in Israel or Israel-controlled territories, with the specific intent to accomplish a boycott or divestment of Israel. The bidder has also not retaliated against any person or other entity for reporting such refusal, termination, or commercially limiting actions. The state reserves the right to reject any bid if this certification is subsequently determined to be false and to terminate any contract awarded based on such a false response.

ARTICLE 6 CONSIDERATION OF BIDS

6.1 Opening of Bids

See Guidelines for Electronic Submission of Bids and Virtual Bid Openings on page 5 of this solicitation.

- 6.1.1 The properly identified Bids received on time will be opened publicly and will be read aloud, and a tabulation abstract of the amounts of the base bids and alternates, if any, will be made available to Bidders.

6.2 Rejection of Bids

- 6.2.1 The Owner shall have the right to reject any or all bids and in particular to reject a bid not accompanied by any required bid security or data required by the Bid Documents or a bid in any way incomplete or irregular.

6.3 Acceptance of Bid

- 6.3.1 It is the intent of the Owner, if he accepts any alternates, to accept them in the order in which they are listed in the Bid Form. Determination of the Low Bidder shall be on the basis of the sum of the base bid and the alternates accepted. However, the Owner shall reserve the right to accept alternates in any order which does not affect determination of the Low Bidder.

ARTICLE 7 POST-BID INFORMATION

7.1 Submissions

- 7.1.1 At the Pre-Construction Conference, the Contractor shall submit the following information to the Architect.
 - 7.1.1.1 A designation of the work to be performed by the Contractor with his own forces.
 - 7.1.1.2 A breakdown of the Contract cost attributable to each item listed in the Schedule of Values Form (attached). No payments will be made to the Contractor until this is received.
 - 7.1.1.3 The proprietary names and the suppliers of principal items or systems of material and equipment proposed for the work.
 - 7.1.1.4 A list of names and business domiciles of all Subcontractors, manufacturers, suppliers or other persons or organizations (including those who are to furnish materials or equipment fabricated to a

special design) proposed for the principal portions of the work. It is the preference of the Owner that, to the greatest extent possible or practical, the Contractor utilize Louisiana Subcontractors, manufacturers, suppliers, and labor.

- 7.1.2 The General Contractor shall be responsible for actions or inactions of Subcontractors and/or material suppliers.

The General Contractor is totally responsible for any lost time or extra expense incurred due to a Subcontractor's or Material Supplier's failure to perform. Failure to perform includes, but is not limited to, a Subcontractor's financial failure, abandonment of the Project, failure to make prompt delivery, or failure to do work up to standard. Under no circumstances shall the Owner mitigate the General Contractor's losses or reimburse the General Contractor for losses caused by these events.

- 7.1.3 The lowest responsive and responsible bidder shall submit to the Architect and the Owner within ten days after the bid opening a letter/letters from the manufacturer stating that the manufacturer will issue the roof system guarantee complying with the requirements of Facility Planning and Control based on the specified roof system and include the name of the applicator acceptable to the manufacturer at the highest level of certification for installing the specified roof system. This manufacturer shall be one that has received prior approval or is named in the specifications.

In accordance with La. R.S. 38:2227 [references La R.S. 38:2212(A)(3)(c)(ii), which has since been renumbered as La R.S. 38:2212(B)(3)], La. R.S. 38:2212.10 and La. R.S. 23:1726(B) the apparent low bidder on this Project shall submit the completed Attestations Affidavit (Past Criminal Convictions of Bidders, Verification of Employees and Certification Regarding Unpaid Workers Compensation Insurance) form found within this bid package to the University of Louisiana at Lafayette within 10 days after the opening of bids.

ARTICLE 8

PERFORMANCE AND PAYMENT BOND

8.1 Bond Required

- 8.1.1 The Contractor shall furnish and pay for a Performance and Payment Bond written by a company licensed to do business in Louisiana, which shall be signed by the surety's agent or attorney-in-fact, in an amount equal to 100% of the Contract amount. Surety must be listed currently on the U. S. Department of Treasury Financial Management Service List (Treasury List) as approved for an amount equal to or greater than the contract amount or must be an insurance company domiciled in Louisiana or owned by Louisiana residents. If surety is qualified other than by listing on the Treasury list, the contract amount may not exceed fifteen percent of policyholders' surplus as shown by surety's most recent financial statements filed with the Louisiana Department of Insurance and may not exceed the amount of \$500,000. However, a Louisiana domiciled insurance company with at least an A- rating in the latest printing of the A. M. Best's Key Rating Guide shall not be subject to the \$500,000 limitation, provided that the contract amount does not exceed ten percent of policyholders' surplus as shown in the latest A. M. Best's Key Rating Guide nor fifteen percent of policyholders' surplus as shown by surety's most recent financial statements filed with the Louisiana Department of Insurance. The Bond shall be signed by the surety's agent or attorney-in-fact. The Bond shall be in favor of the University of Louisiana at Lafayette.

8.2 Time of Delivery and Form of Bond

- 8.2.1 The Bidder shall deliver the required bond to the Owner simultaneous with the execution of the Contract.
- 8.2.2 A surety company's bid bond form/document will be sufficient for any bid submission.
- 8.2.3 The Bidder shall require the Attorney-in-Fact who executes the required bond on behalf of the surety to affix thereto a certified and current copy of his power of Attorney.

ARTICLE 9

FORM OF AGREEMENT BETWEEN OWNER AND CONTRACTOR

9.1 Form to be Used

- 9.1.1 Form of the Contract to be used shall be furnished by the University of Louisiana at Lafayette, an example of which is bound in the Bid Documents.
- 9.2 Award
- 9.2.1 After award of the Contract, the successful Bidder, if a corporation, shall furnish to the Owner the most current copy of a Disclosure of Ownership Affidavit on file with the Secretary of State.
- 9.2.2 In accordance with Louisiana Law, when the Contract is awarded, the successful Bidder shall, at the time of the signing of the Contract, execute the Non-Collusion Affidavit included in the Contract Documents
- 9.2.3 When this Project is financed either partially or entirely with State Bonds, the award of this Contract is contingent upon the sale of bonds by the State Bond Commission. The State shall incur no obligation to the Contractor until the Contract Between Owner and Contractor is duly executed.

END OF SECTION

SUPPLEMENTARY CONDITIONS

https://www.doa.la.gov/.../27_Supplementary_Conditions_April2018.docx

These Supplementary Conditions modify, change, delete from or add to the General Conditions of the Contract for Construction, AIA Document A201, 2017 Edition. Where any Article of the General Conditions is modified or any Section, Paragraph, Subparagraph or Clause thereof is modified or deleted by these supplements, the unaltered provisions of that Section, Article, Paragraph, Subparagraph or Clause shall remain in effect.

Articles, Sections, Paragraphs, Subparagraphs or Clauses modified or deleted have the same numerical designation as those occurring in the General Conditions.

ARTICLE 1

GENERAL PROVISIONS

1.1 BASIC DEFINITIONS

1.1.1 The Contract Documents

In Section 1.1.1 delete the third sentence, and add the following sentence:

The Contract Documents shall include the Bid Documents as listed in the Instructions to Bidders and any modifications made thereto by addenda.

1.1.8 Initial Decision Maker

Delete all after the words, "shall not show partiality to the Owner or Contractor".

1.5 OWNERSHIP AND USE OF DRAWINGS, SPECIFICATIONS AND OTHER INSTRUMENTS OF SERVICE [REFER TO *La R.S. 38:2317*]

1.5.1 Delete the first sentence of the paragraph.

1.5.1 In the third sentence: delete the remainder after the word "publication".

1.7 DIGITAL DATA USE AND TRANSMISSION

In the first sentence after the words, "in digital form" delete ". The parties will use AIA Document E203 2013, Building Information Modeling and Digital Data Exhibit".

1.8 BUILDING INFORMATION MODELS USE AND RELIANCE

Delete Section 1.8.

ARTICLE 2

OWNER

2.2 EVIDENCE OF THE OWNER'S FINANCIAL ARRANGEMENTS

Delete Section 2.2.

2.3 INFORMATION AND SERVICES REQUIRED OF THE OWNER

2.3.1 In the first sentence, delete: all before "the Owner shall secure..."

Delete Section 2.3.2 and substitute the following:

2.3.2 The term Architect, when used in the Contract Documents, shall mean the prime Designer (Architect, Engineer, or Landscape Architect), or his authorized representative, lawfully licensed to practice architecture, engineering, or landscape architecture in the State of Louisiana, identified as such in the Agreement and is referred to throughout the Contract Documents as if singular in number.

2.3.3 Delete the words: "to whom the Contractor has no reasonable objection and".

ARTICLE 3

CONTRACTOR

3.4 LABOR AND MATERIALS

3.4.2 Delete Section 3.4.2.

Delete Section 3.4.3 and substitute with the following:

3.4.3 Contractor and its employees, officers, agents, representatives, and Subcontractors shall conduct themselves in an appropriate and professional manner, in accordance with the Owner's requirements, at all times while working on the Project. Any such individual who behaves in an inappropriate manner or who engages in the use of inappropriate language or conduct while on Owner's property, as determined by the Owner, shall be removed from the Project at the Owner's request. Such individual shall not be permitted to return without the written permission of the Owner. The Owner shall not be responsible or liable to Contractor or any Subcontractor for any additional costs, expenses, losses, claims or damages incurred by Contractor or its Subcontractor as a result of the removal of an individual from the Owner's property pursuant to this Section. The Contractor shall not permit employment of unfit persons or persons not properly skilled in tasks assigned to them.

3.5 WARRANTY

3.5.2 Replace reference to "Section 9.8.4" with "Section 9.8.6".

3.7 PERMITS, FEES, NOTICES, AND COMPLIANCE WITH LAWS (La R.S. 40:1724[A])

3.7.1 Delete Section 3.7.1.

3.7.2 In Section 3.7.2, replace the word "public" with the word "State".

Delete Section 3.7.5 and substitute the following:

3.7.5 If, during the course of the Work, the Contractor discovers human remains, unmarked burial or archaeological sites, burial artifacts, or wetlands, which are not indicated in the Contract Documents, the Contractor shall follow all procedures mandated by State and Federal law, including but not limited to La R.S. 8:671 et seq., the Office of Coastal Protection and Restoration, and Sections 401 & 404 of the Federal Clean Water Act. Request for adjustment of the Contract Sum and Contract Time arising from the

existence of such remains or features shall be submitted in writing to the Owner pursuant to the Contract Documents.

3.8 ALLOWANCES

Delete Sections 3.8.1, 3.8.2, and 3.8.3 in their entirety and add the following new Section 3.8.1:

3.8.1 Allowances shall not be made on any of the Work.

3.9 SUPERINTENDENT

3.9.1 Add the following to the end of the paragraph:
Important communications shall be confirmed in writing. Other communications shall be similarly confirmed on written request in each case.

3.10 CONTRACTOR'S CONSTRUCTION AND SUBMITTAL SCHEDULES

3.10.1 Add the following: For Projects with a contract sum greater than \$1,000,000.00, the Contractor shall include with the schedule, for the Owner's and Architect's information, a network analysis to identify those tasks which are on the critical path, i.e., where any delay in the completion of these tasks will lengthen the Project timescale, unless action is taken. A revised schedule shall be submitted with each Application and Certificate for Payment. No payment shall be made until this schedule is received.

3.10.3 In the first sentence, delete the word "general".

After the first sentence, add the following:

If the Work is not on schedule, as determined by the Architect, and the Contractor fails to take action to bring the Work on schedule, then the Contractor shall be deemed in default under this Contract and the progress of the Work shall be deemed unsatisfactory. Such default may be considered grounds for termination by the Owner for cause in accordance with Section 14.2.

Add the following Sections:

3.10.4 Add the following: Submittal by the contractor of a schedule or other documentation showing a completion date for his Work prior to the completion date stated in the contract shall not impose any obligation or responsibility on the Owner or Architect for the earlier completion date.

3.10.5 In the event the Owner employs a commissioning consultant, the Contractor shall cooperate fully in the commissioning process and shall require all subcontractors and others under his control to cooperate. The purpose of such services shall be to ensure that all systems perform correctly and interactively according to the provisions of the Contract Documents.

3.11 DOCUMENTS AND SAMPLES AT THE SITE

Add the following: This requirement is of the essence of the contract. The Architect shall determine the value of these documents and this amount shall not be approved for payment to the Contractor until all of the listed documents are delivered to the Architect in good order, completely marked with field changes and otherwise complete in all aspects.

ARTICLE 4 ARCHITECT

4.2 ADMINISTRATION OF THE CONTRACT

4.2.1 In the first sentence, delete the phrase: "the date the Architect issues the final Certificate for Payment" and replace with the phrase "final payment is due, and with the Owner's concurrence, from time to time during the one year period for correction of Work described in Section 12.2."

- 4.2.2 In the first sentence, after the phrase: “become generally familiar with”; insert the following: “and to keep the Owner informed about”.
- In the first sentence, after the phrase “portion of the Work completed”, insert the following: “to endeavor to guard the Owner against defects and deficiencies in the Work,”
- 4.2.4 In the first sentence, delete all after “The Owner and Contractor”, and add the following “may communicate directly with each other, when deemed necessary by the Owner, and the Owner will notify the Architect of any decision.”
- 4.2.10 Add the following sentence to the end of Section 4.2.10: There shall be no restriction on the Owner having a Representative.
- 4.2.11 Add the following sentence to the end of Section 4.2.11:
If no agreement is made concerning the time within which interpretation required of the Architect shall be furnished in compliance with this Section 4.2, then delay shall not be recognized on account of failure by the Architect to furnish such interpretation until 15 days after written request is made for them.
- 4.2.14 Insert the following sentence between the second and third sentences of Section 4.2.14:
If no agreement is made concerning the time within which interpretation required of the Architect shall be furnished in compliance with this Section 4.2, then delay shall not be recognized on account of failure by the Architect to furnish such interpretation until 15 days after written request is made for them.

ARTICLE 5

SUBCONTRACTORS

5.2 AWARD OF SUBCONTRACTS AND OTHER CONTRACTS FOR PORTIONS OF THE WORK

Delete Section 5.2.1, and substitute the following:

- 5.2.1 Unless otherwise required by the Contract Documents, the Contractor shall furnish at the Pre-Construction Conference, to the Owner and the Architect, in writing, the names of the persons or entities (including those who are to furnish materials or equipment fabricated to a special design) proposed for each of the principal portions of the Work. No Contractor payments shall be made until this information is received.

5.2.2

Delete Section 5.2.2, and substitute the following:

- 5.2.2 The Contractor shall be solely responsible for selection and performance of all subcontractors. The Contractor shall not be entitled to claims for additional time and/or an increase in the contract sum due to a problem with performance or nonperformance of a subcontractor.

Delete Sections 5.2.3 and 5.2.4 and substitute the following:

- 5.2.3 The Contractor shall notify the Architect and the Owner when a subcontractor is to be changed and substituted with another subcontractor.

5.4 CONTINGENT ASSIGNMENT OF SUBCONTRACTS

Delete Sections 5.4, 5.4.1, 5.4.2 and 5.4.3

ARTICLE 7

CHANGES IN THE WORK

7.1 GENERAL

Add the following Sections:

- 7.1.4 As part of the pre-construction conference submittals, the Contractor shall submit the following prior to the Contractor's initial request for payment:
- 7.1.4.1 Fixed job site overhead cost itemized with documentation to support daily rates.
 - 7.1.4.2 Bond Premium Rate with supporting information from the General Contractor's carrier.
 - 7.1.4.3 Labor Burden by trade for both Subcontractors and General Contractor. The Labor Burden shall be supported by the Worker's Compensation and Employer's Liability Insurance Policy Information Page. Provide for all trades.
 - 7.1.4.4 Internal Rate Charges for all significant company owned equipment.
- 7.1.5 If the General Contractor fails to submit the aforementioned documentation as part of the pre-construction submittals, then pay applications shall not be processed until such time as the Owner receives this information.

7.2 CHANGE ORDERS

Delete Section 7.2.1, and substitute the following Sections:

- 7.2.1 A Change Order is a written instrument prepared by the Architect and signed by the Owner, the Architect, and the Contractor issued after execution of the Contract, authorizing a change in the Work and/or an adjustment in the Contract Sum and/or the Contract Time. The Contract Sum and the Contract Time may be changed only by Change Order. A Change Order signed by the Contractor indicates his agreement therewith, including the adjustment in the Contract Sum or the Contract Time. Any reservation of rights, stipulation, or other modification made on the change order by the contractor shall have no effect.
- 7.2.2 "Cost of the Work" for the purpose of Change Orders shall be the eligible costs required to be incurred in performance of the Work and paid by the Contractor and Subcontractors which eligible costs shall be limited to:
- 7.2.2.1 Actual wages paid directly to labor personnel, with a labor burden markup exclusively limited to applicable payroll taxes, worker's compensation insurance, unemployment compensation, and social security taxes for those labor personnel performing the Work. Wages shall be the basic hourly labor rate paid an employee exclusive of fringe benefits or other employee costs. The labor burden percentage for the "Cost of the Work" is limited to categories listed herein. Employer-provided health insurance, fringe benefits, employee training (whether a requirement of employment or not), vacation pay, etc., are examples of ineligible labor burden costs which *shall not* be included, as these costs are already compensated by the Overhead and Profit markup.

Supervision shall not be included as a line item in the "Cost of the Work", except when the change results in a documented delay in the critical path, as described in Section 7.2.7.
 - 7.2.2.2 Cost of all materials and supplies necessary and required to perform the Work, identifying each item and its individual cost, including taxes. Incidental consumables are not eligible costs and shall not be included.
 - 7.2.2.3 Cost of each necessary piece of machinery and equipment required to perform the Work, identifying each item and its individual cost, including taxes. Incidental small tools of a specific trade (i.e., shovels, saws, hammers, air compressors, etc.) and general use vehicles, such as pickup trucks even for moving items around the site, fuel for these general use vehicles, travel, lodging, and/or meals are not eligible and shall not be included.
 - 7.2.2.4 Eligible Insurance costs shall be limited to documented increases in "Builder's Risk" insurance

premium / costs only. Commercial General Liability, Automobile Liability, and all other required insurances, where referenced in the Contract shall be considered part of normal overhead. These costs are already compensated by the Overhead and Profit markup.

- 7.2.2.5 Cost for the General Contractor Performance and Payment Bond premium, where the documented cost of the premiums have been increased due to the Change Order.
- 7.2.3 Overhead and Profit - The Contractor and Subcontractor shall be due home office fixed overhead and profits on the Cost of the Work but shall not exceed a total of 16% of the direct cost of any portion of Work. The credit to the Owner resulting from a change in the Work shall be the sum of those items above, except credit will not be required for Overhead and Profit. Where a change results in both credits to the Owner and extras to the Contractor for related items, overhead and profit shall only be computed on the net extra cost to the Contractor.
- 7.2.4 The cost to the Owner resulting from a change in the Work shall be the sum of: Cost of the Work (as defined at Section 7.2.2) and Overhead and Profit (as defined at Section 7.2.3), and shall be computed as follows:
- 7.2.4.1 When all of the Work is General Contractor Work; 8% markup on the Cost of the Work.
- 7.2.4.2 When the Work is all Subcontract Work; 8% markup on the Cost of the Work for Subcontractor's Overhead and Profit, plus 8% markup on the Cost of the Work, not including the Subcontractor's Overhead and Profit markup, for General Contractor's Overhead and Profit.
- 7.2.4.3 When the Work is a combination of General Contractor Work and Subcontract Work; that portion of the direct cost that is General Contract Work shall be computed per Section 7.2.4.1 and that portion of the direct cost that is Subcontract Work shall be computed per Section 7.2.4.2.
- Premiums for the General Contractor's bond may be included, but after the markup is added to the Cost of the Work.
Premiums for the Subcontractor's Bond shall not be included.
- 7.2.4.4 Subcontract cost shall consist of the items in Section 7.2.2 above plus Overhead and Profit as defined in Section 7.2.3.
- 7.2.5 Before a Change Order is prepared, the Contractor shall prepare and deliver to the Architect the following information concerning the Cost of the Work, not subject to waiver, within a reasonable time after being notified to prepare said Change Order:
- A detailed, itemized list of labor, material and equipment costs for the General Contractor's Work including quantities and unit costs for each item of labor, material and equipment.
- An itemized list of labor, material and equipment costs for each Subcontractor's and/or Sub-Subcontractor's Work including quantities and unit costs for each item of labor, material and equipment.
- 7.2.6 After a Change Order has been approved, no future requests for extensions of time or additional cost shall be considered for that Change Order.
- 7.2.7 Extended fixed job-site costs are indirect costs that are necessary to support the work in the field. Examples of fixed job-site costs are field office rental, salaries of field office staff, field office utilities and telephone.
- Extended fixed job-site costs or equitable adjustment, may be included in a Change Order due to a delay in the critical path, with the exception of weather related delays. In the event of a delay in the critical path, the Contractor shall submit all changes or adjustments to the Contract Time within twenty-one (21) days

of the event giving rise to the delay. The Contractor shall submit documentation and justification for the adjustment by performing a critical path analysis of its most recent schedule in use prior to the change, which shows an extension in critical path activities.

The Contractor shall notify the Architect in writing that the Contractor is making a claim for extended fixed job-site overhead as required by Section 15.1.2. The Contractor shall provide proof that the Contractor is unable to mitigate financial damages through Alternate Work within this Contract or replacement work. "Replacement Work" is that work which the Contractor is obligated to perform under any construction contract separate from this Contract. Reasonable proof shall be required by the Architect that the delays affected the Completion Date.

- 7.2.8 "Cost of the Work" whether General Contractor cost or Subcontractor cost shall not apply to the following:
- 7.2.8.1 Salaries or other compensation of the Contractor's personnel at the Contractor's principal office and branch offices.
 - 7.2.8.2 Any part of the Contractor's capital expenses, including interest on the Contractor's capital employed for the Work.
 - 7.2.8.3 Overhead and general expenses of any kind or the cost of any item not specifically and expressly included above in Cost of the Work.
 - 7.2.8.4 Cost of supervision, refer to section 7.2.2.1, with exception as provided in Section 7.2.7.
- 7.2.9 When applicable as provided by the Contract, the cost to Owner for Change Orders shall be determined by quantities and unit prices. The quantity of any item shall be as submitted by the Contractor and approved by the Architect. Unit prices shall cover cost of Material, Labor, Equipment, Overhead and Profit.
- 7.3 CONSTRUCTION CHANGE DIRECTIVES
- 7.3.3 In the first sentence after "following methods" insert: ", but not to exceed a specified amount".
- 7.3.4 From .1 of the list, delete all after "Costs of labor, including" and substitute the following "social security, old age and employment insurance, applicable payroll taxes, and workers' compensation insurance;"
- Delete the following from .4 of the list: "permit fees,"
- Delete Section 7.3.9 and substitute the following:
- 7.3.9 Pending final determination of the total costs of a Construction Change Directive to the Owner, amounts not in dispute for such changes in the Work shall be included in Applications for Payment accompanied by a Change Order indicating the parties' agreement with part or all of such costs.

ARTICLE 8 TIME

8.1 DEFINITIONS

Add the following:

8.1.5 The Contract Time shall not be changed by the submission of a schedule that shows an early completion date unless specifically authorized by change order.

8.2 PROGRESS AND COMPLETION

Add to Section 8.2.1 the following:

Completion of the Work must be within the Time for Completion stated in the Agreement, subject to such

extensions as may be granted under Section 8.3. The Contractor agrees to commence Work not later than fourteen (14) days after the transmittal date of Written Notice to Proceed from the Owner and to substantially complete the Project within the time stated in the Contract. The Owner will suffer financial loss if the Project is not substantially complete in the time set forth in the Contract Documents. The Contractor and the Contractor's Surety shall be liable for and shall pay to the Owner the sum stated in the Contract Documents as fixed, agreed and liquidated damages for each consecutive calendar day (Saturdays, Sundays and holidays included) of delay until the Work is substantially complete. The Owner shall be entitled to the sum stated in the Contract Documents. Such Liquidated Damages shall be withheld by the Owner from the amounts due the Contractor for progress payments.

Delete Section 8.2.2.

8.3 DELAYS AND EXTENSIONS OF TIME

8.3.1 In the first sentence after the words "Owner pending" delete the words "mediation and binding dispute resolution" and add the word "litigation", and delete the last word "determine" and add the following: "recommend, subject to Owner's approval of Change Order. If the claim is not made within the limits of Article 15, all rights for future claims for that month are waived."

ARTICLE 9

PAYMENTS AND COMPLETION

9.1 CONTRACT SUM

Delete Section 9.1.2.

Delete Section 9.2 and substitute the following:

9.2 SCHEDULE OF VALUES

At the Pre-Construction Conference, the Contractor shall submit to the Owner and the Architect a Schedule of Values prepared as follows:

9.2.1 The attached Schedule of Values Format shall be used. If applicable, the cost of Work for each section listed under each division, shall be given. The cost for each section shall include Labor, Materials, Overhead and Profit.

9.2.2 The Total of all items shall equal the Total Contract Sum. This schedule, when approved by the Architect, shall be used as a basis for the Contractor's Applications for Payment and it may be used for determining the cost of the Work in deductive change orders, when a specific item of Work listed on the Schedule of Values is to be removed. Once the Schedule of Values is submitted at the Pre-Construction Conference, the schedule shall not be modified without approval from the Owner and Architect.

9.3 APPLICATIONS FOR PAYMENT

Delete Sections 9.3.1, 9.3.1.1, and 9.3.1.2 and substitute the following:

9.3.1 Monthly, the Contractor shall submit to the Architect an Application & Certificate for Payment on the AIA Document G702-1992, accompanied by AIA Document G703-1992, and supported by any additional data substantiating the Contractor's right to payment as the Owner or the Architect may require. Application for Payment shall be submitted on or about the first of each month for the value of labor and materials incorporated into the Work and of materials, suitably stored, at the site as of the twenty-fifth day of the preceding month, less normal retainage as follows, per La R.S. 38:2248:

9.3.1.1 Projects with Contract price up to \$500,000.00 – 10% of the Contract price.

9.3.1.2 Projects with Contract price of \$500,000.00, or more –5% of the Contract price.

9.3.1.3 No payment shall be made until the revised schedule required by Section 3.10.1 is received.

9.3.1.4 The normal retainage shall not be due the Contractor until after substantial completion and

expiration of the forty-five day lien period and submission to the Architect of a clear lien certificate, consent of surety, and invoice for retainage.

Delete Section 9.3.2 and substitute the following:

9.3.2 Unless otherwise provided in the Contract Documents, payments shall be made on account of materials and equipment delivered and suitably stored at the site for subsequent incorporation in the Work. Payments for materials or equipment stored on the site shall be conditioned upon submission by the Contractor of bills of sale or such other procedures satisfactory to the Owner to establish the Owner's title to such materials and equipment or otherwise protect the Owner's interest, including applicable insurance.

9.5 DECISIONS TO WITHHOLD CERTIFICATION

Section 9.5.1.7: Delete the word "repeated".

Delete Section 9.5.4.

9.6 PROGRESS PAYMENTS

Delete Section 9.6.1 and substitute the following:

9.6.1 After the Architect has issued a Certificate for Payment, the Owner shall make payment within twenty days except for Projects funded fully or in part by a Federal reimbursement program. For such Projects the Owner will make payment in a timely manner consistent with reimbursement.

9.6.2 Delete the phrase: "no later than seven days" from the first sentence.

After the end of the second sentence, add the following:

La R.S. 9:2784 (A) and (C) require a Contractor or Subcontractor to make payment due to each Subcontractor and supplier within fourteen (14) consecutive days of the receipt of payment from the Owner. If not paid, a penalty in the amount of ½ of 1% per day is due, up to a maximum of 15% from the expiration date until paid. The contractor or subcontractor, whichever is applicable, is solely responsible for payment of a penalty.

9.6.4 Delete the first two sentences of Section 9.6.4 and add the following to the end of the Section:

Pursuant to La. R.S. 38:2242 and La. R.S. 38:2242.2, when the Owner receives any claim of nonpayment arising out of the Contract, the Owner shall deduct 125% of such claim from the Contract Sum. The Contractor, or any interested party, may deposit security, in accordance with La. R.S. 38:2242.2, guaranteeing payment of the claim with the recorder of mortgages of the parish where the Work has been done. When the Owner receives original proof of such guarantee from the recorder of mortgages, the claim deduction will be added back to the Contract Sum.

Delete Section 9.7 FAILURE OF PAYMENT.

Delete Section 9.8 and substitute the following:

9.8 SUBSTANTIAL COMPLETION

9.8.1 Substantial Completion is the stage in the progress of the Work when the Work is sufficiently complete in accordance with the Contract Documents so that the Owner can occupy or utilize the Work for its intended use. The Architect shall determine if the Project is substantially complete in accordance with this Section.

9.8.2 When the Contractor considers that the Work is Substantially Complete, the Contractor shall prepare and submit to the Architect a comprehensive list of items to be completed or corrected prior to final

payment. Failure to include an item on such list does not alter the responsibility of the Contractor to complete all Work in accordance with the Contract Documents.

- 9.8.3 Upon receipt of the Contractor's list, the Architect shall make an inspection to determine whether the Work is substantially complete. A prerequisite to the Work being considered as substantially complete is the Owner's receipt of the executed Roofing Contractor's and Roofing Manufacturer's guarantees, where roofing Work is part of the Contract. Prior to inspection by the Architect, the Contractor shall notify the Architect that the Project is ready for inspection by the State Fire Marshal's office. If the Architect's inspection discloses any item, whether or not included on the Contractor's list, which is not sufficiently complete in accordance with the Contract Documents so that the Owner can occupy or utilize the Work for its intended use, the Contractor shall, before the Work can be considered as Substantially Complete, complete, or correct such item upon notification by the Architect. In such case, the Contractor shall then submit a request for another inspection by the Architect to determine Substantial Completion.
- 9.8.4 When the Architect determines that the Project is Substantially Complete, he shall prepare a punch list of exceptions and the dollar value related thereto. The monetary value assigned to this list will be the sum of the cost estimate for each particular item of Work the Architect develops based on the mobilization, labor, material, and equipment costs of correcting the item and shall be retained from the monies owed the contractor, above and beyond the standard lien retainage. The cost of these items shall be prepared in the same format as the schedule of values. At the end of the forty-five day lien period payment shall be approved for all punch list items completed up to that time. After that payment, none of the remaining funds shall be due the contractor until all punch list items are completed and are accepted by the Architect. If the dollar value of the punch list exceeds the amount of funds, less the retainage amount, in the remaining balance of the Contract, then the Project shall not be considered as substantially complete. If funds remaining are less than that required to complete the Work, the Contractor shall pay the difference.
- 9.8.5 When the preparation of the punch list is complete the Architect shall prepare a Recommendation of Acceptance incorporating the punch list and submit it to the Owner. Upon approval of the Recommendation of Acceptance, the Owner may issue a Notice of Acceptance of Building Contract which shall establish the Date of Substantial Completion. The Contractor shall record the Notice of Acceptance with the Clerk of Court in the Parish in which the Work has been performed. If the Notice of Acceptance has not been recorded seven (7) days after issuance, the Owner may record the Acceptance at the Contractor's expense. All additive change orders must be processed before issuance of the Recommendation of Acceptance. The Owner shall not be responsible for payment for any Work associated with change orders that is not incorporated into the contract at the time of the Recommendation of Acceptance.
- 9.8.6 Warranties required by the Contract Documents shall commence on the date of Acceptance of the Work unless otherwise agreed to in writing by the Owner and Contractor. Unless otherwise agreed to in writing by the Owner and Contractor, security, maintenance, heat, utilities, damage to the Work not covered by the punch list and insurance shall become the Owner's responsibility on the Date of Substantial Completion.
- 9.8.7 If all punch list items have not been completed by the end of the forty-five (45) day lien period, through no fault of the Architect or Owner, the Owner may hold the Contractor in default. If the Owner finds the Contractor is in default, the Surety shall be notified. If within forty-five (45) days after notification, the Surety has not completed the punch list, through no fault of the Architect or Owner, the Owner may, at his option, contract to have the balance of the Work completed and pay for such Work with the unpaid funds remaining in the Contract sum. Finding the Contractor in default shall constitute a reason for disqualification of the Contractor from bidding on future state contracts. If the surety fails to complete the punch list within the stipulated time period, the Owner may not accept bonds submitted, in the future, by the surety.

9.9 PARTIAL OCCUPANCY OR USE

Delete Section 9.9.1 and substitute the following:

9.9.1 Partial Occupancy is that stage in the progress of the Work when a designated portion of the Work is sufficiently complete in accordance with the Contract Documents so the Owner can occupy or utilize the designated portion of the Work for its intended use. The Owner may occupy or use any substantially completed portion of the Work so designated by separate agreement with the Contractor and authorized by public authorities having jurisdiction over the Work. Such occupancy or use may commence provided the Owner and Contractor have accepted in writing the responsibilities assigned to each of them for payments, if any, security, maintenance, heat, utilities, damage to the Work and insurance, and have agreed in writing concerning the period for correction of the Work and commencement of warranties required by the Contract Documents. When the Contractor considers the designated portion substantially complete the Contractor shall prepare and submit a list to the Architect as provided under Section 9.8.2. Consent of the Contractor to partial occupancy or use shall not be unreasonably withheld.

9.10 FINAL COMPLETION AND FINAL PAYMENT

9.10.1 After the second sentence, add the following:

If the Architect does not find the Work acceptable under the Contract Documents, the Architect shall make one additional inspection; if the Work is still not acceptable, the Architect, and each of the Architect's principal consultants, shall be paid \$175.00/hour for their time at the Project site, for each additional inspection, to be withheld from the unpaid funds remaining in the Contract sum. The payment shall be made by the Owner and deducted from the construction contract funds.

Delete Section 9.10.4 and replace with the following:

9.10.4 The making of final payment shall not constitute a waiver of Claims by the Owner for the following:

9.10.4.1 Claims, security interests, or encumbrances arising out of the Contract and unsettled;

9.10.4.2 failure of the Work to comply with the requirements of the Contract Documents irrespective of when such failure is discovered;

9.10.4.3 terms of special warranties required by the Contract Documents; or

9.10.4.4 audits performed by the Owner, after final payment.

ARTICLE 10

PROTECTION OF PERSONS AND PROPERTY

10.2 SAFETY OF PERSONS AND PROPERTY

10.2.2 In the first sentence, between the words: "bearing on" and "safety", add the words: "the health and,"

10.3 HAZARDOUS MATERIALS

10.3.1 In the second sentence after (PCB) add: "or lead".

10.3.2 After the first sentence, delete all remaining sentences.

Add at the end: "The Contract time shall be extended appropriately."

Delete Section 10.4 and substitute the following:

10.4 EMERGENCIES

In an emergency affecting the safety of persons or property, the Contractor shall notify the Owner and Architect immediately of the emergency, simultaneously acting at his discretion to prevent damage, injury or loss. Any additional compensation or extension of time claimed by the Contractor on account of emergency Work shall be determined as provided in Article 15 and Article 7.

ARTICLE 11

INSURANCE AND BONDS

AIA A101 – 2017 Exhibit A is not a part of these documents. Delete all of Sections 11.1, 11.2, 11.3, 11.4, and 11.5, and substitute the following:

INSURANCE REQUIREMENTS FOR NEW CONSTRUCTION, ADDITIONS AND RENOVATIONS

11.1 CONTRACTOR'S LIABILITY INSURANCE

The Contractor shall purchase and maintain without interruption for the duration of the contract insurance against claims for injuries to persons or damages to property which may arise from or in connection with the performance of the Work hereunder by the Contractor, its agents, representatives, employees or subcontractors. The duration of the contract shall be from the inception of the contract until the date of final payment.

11.2 MINIMUM SCOPE AND LIMITS OF INSURANCE

11.2.1 Worker's Compensation

Worker's Compensation insurance shall be in compliance with the Worker's Compensation law of the Contractor's headquarters. Employers Liability is included with a minimum limit of \$1,000,000 per accident/per disease/per employee. If Work is to be performed over water and involves maritime exposure, applicable LHWCA, Jones Act or other maritime law coverage shall be included. A.M. Best's insurance company rating requirement may be waived for Worker's compensation coverage only.

11.2.2 Commercial General Liability

Commercial General Liability insurance, including Personal and Advertising Injury Liability and Products and Completed Operations Liability, shall have a minimum limit per occurrence based on the Project value. The Insurance Services Office (ISO) Commercial General Liability occurrence coverage form CG 00 01 (current form approved for use in Louisiana), or equivalent, is to be used in the policy. Claims-made form is unacceptable.

The aggregate loss limit must apply to each Project. ISO form CG 25 03 (current form approved for use in Louisiana), or equivalent, shall also be submitted. The State Project number, including part number, and Project name shall be included on this endorsement.

COMBINED SINGLE LIMIT (CSL) PER OCCURRENCE

Type of Construction	Projects up to \$1,000,000	Projects over \$1,000,000 up to \$50,000,000	Projects over \$50,000,000
New Buildings:			
Each Occurrence			
Minimum Limit	\$1,000,000	\$2,000,000	\$4,000,000
Per Project Aggregate	\$2,000,000	\$4,000,000	\$8,000,000
Renovations:	The building(s) value for the Project is \$_____.		
Each Occurrence			
Minimum Limit	\$1,000,000**	\$2,000,000**	\$4,000,000**
Per Project Aggregate	2 times per	2 times per	2 times per

occur limit**

occur limit**

occur limit**

**While the minimum Combined Single Limit of \$1,000,000 is required for any renovation, the limit is calculated by taking 10% of the building value and rounding it to the nearest \$1,000,000 to get the insurance limit. Example: Renovation on a \$33,000,000 building would have a calculated \$3,300,000 combined single limit of coverage (33,000,000 times .10 = 3,300,000 and then rounding down to \$3,000,000). If the calculated limit is less than the minimum limit listed in the above chart, then the amount needed is the minimum listed in the chart. Maximum per occurrence limit required is \$50,000,000 regardless of building value. The per Project aggregate limit is then calculated as twice the per occurrence limit.

11.2.3 Automobile Liability

Automobile Liability Insurance shall have a minimum combined single limit per occurrence of \$1,000,000. ISO form number CA 00 01 (current form approved for use in Louisiana), or equivalent, is to be used in the policy. This insurance shall include third-party bodily injury and property damage liability for owned, hired and non-owned Automobiles.

11.2.4 Excess Umbrella

Excess Umbrella Insurance may be used to meet the minimum requirements for General Liability and Automobile Liability only.

11.2.5 Builder's Risk

11.2.5.1 Builder's Risk Insurance shall be in an amount equal to the amount of the construction contract including any amendments and shall be upon the entire Work included in the contract. The policy shall provide coverage equivalent to the ISO form number CP 10 20, Broad Form Causes of Loss (extended, if necessary, to include the perils of wind, earthquake, collapse, vandalism/malicious mischief, and theft, including theft of materials whether or not attached to any structure). The policy must include architects' and engineers' fees necessary to provide plans, specifications and supervision of Work for the repair and/or replacement of property damage caused by a covered peril, not to exceed 10% of the cost of the repair and/or replacement.

11.2.5.2 Flood coverage shall be provided by the Contractor on the first floor and below for all Projects, except as otherwise noted. The builder's risk insurance policy, sub-limit for flood coverage shall not be less than ten percent (10%) of the total contract cost per occurrence. If flood is purchased as a separate policy, the limit shall be ten percent (10%) of the total contract cost per occurrence (with a max of \$500,000 if NFIP). Coverage for roofing Projects shall not require flood coverage.

11.2.5.3 A Specialty Contractor may provide an installation floater in lieu of a Builder's Risk policy, with the similar coverage as the Builder's Risk policy, upon the system to be installed in an amount equal to the amount of the contract including any amendments. Flood coverage is not required.

11.2.5.4 The policy must include coverage for the Owner, Contractor and any subcontractors as their interests may appear.

11.2.6 Pollution Liability (*required when asbestos or other hazardous material abatement is included in the contract*)

Pollution Liability insurance, including gradual release as well as sudden and accidental, shall have a minimum limit of not less than \$1,000,000 per claim. A claims-made form will be acceptable. A policy period inception date of no later than the first day of anticipated Work under this contract and an expiration date of no earlier than 30 days after anticipated completion of all Work under the contract shall be provided. There shall be an extended reporting period of at least 24 months, with full reinstatement of limits, from the expiration date of the policy if the policy is not renewed. The policy shall not be cancelled for any reason, except non-payment of premium.

11.2.7 Deductibles and Self-Insured Retentions

Any deductibles or self-insured retentions must be declared to and accepted by the Owner. The Contractor shall be responsible for all deductibles and self-insured retentions.

11.3 OTHER INSURANCE PROVISIONS

11.3.1 The policies are to contain, or be endorsed to contain, the following provisions:

11.3.1.1 Worker's Compensation and Employers Liability Coverage

11.3.1.1.1 To the fullest allowed by law, the insurer shall agree to waive all rights of subrogation against the Owner, its officers, agents, employees and volunteers for losses arising from Work performed by the Contractor for the Owner.

11.3.1.2 Commercial General Liability Coverage

11.3.1.2.1 The Owner, its officers, agents, employees and volunteers are to be added as additional insureds as respects liability arising out of activities performed by or on behalf of the Contractor; products and completed operations of the Contractor, premises owned, occupied or used by the Contractor. ISO Form CG 20 10 (for ongoing work) AND CG 20 37 (for completed work) (current forms approved for use in Louisiana), or equivalent, are to be used.

11.3.1.2.2 The Contractor's insurance shall be primary as respects the Owner, its officers, agents, employees and volunteers for any and all losses that occur under the contract. The coverage shall contain no special limitations on the scope of protection afforded to the Owner, its officers, officials, employees or volunteers. Any insurance or self-insurance maintained by the Owner shall be excess and non-contributory of the Contractor's insurance.

11.3.1.3 Builder's Risk

The policy must include an endorsement providing the following:

In the event of a disagreement regarding a loss covered by this policy, which may also be covered by a State of Louisiana self-insurance or commercial property policy through the Office of Risk Management (ORM), Contractor and its insurer agree to follow the following procedure to establish coverage and/or the amount of loss:

Any party to a loss may make written demand for an appraisal of the matter in disagreement. Within 20 days of receipt of written demand, the Contractor's insurer and either ORM or its commercial insurance company shall each select a competent and impartial appraiser and notify the other of the appraiser selected. The two appraisers shall select a competent and impartial umpire. The appraisers shall then identify the policy or policies under which the loss is insured and, if necessary, state separately the value of the property and the amount of the loss that must be borne by each policy. If the two appraisers fail to agree, they shall submit their differences to the umpire. A written decision by any two shall determine the policy or policies and the amount of the loss. Each insurance company agrees that the decision of the appraisers and the umpire if involved shall be binding and final and that neither party will resort to litigation. Each of the two parties shall pay its chosen appraiser and bear the cost of the umpire equally.

11.3.1.4 All Coverages

11.3.1.4.1 All policies must be endorsed to require 30 days written notice of cancellation to the Agency. Ten-day written notice of cancellation is acceptable for non-payment of premium. Notifications shall comply with the standard cancellation provisions in the Contractor's policy. In addition, Contractor is required to notify Agency of policy cancellations or reductions in limits.

11.3.1.4.2 Neither the acceptance of the completed Work nor the payment thereof shall release the Contractor from the obligations of the insurance requirements or indemnification agreement.

11.3.1.4.3 The insurance companies issuing the policies shall have no recourse against the Owner for payment of premiums or for assessments under any form of the policies.

11.3.1.4.4 Any failure of the Contractor to comply with reporting provisions of the policy shall not affect coverage provided to the Owner, its officers, agents, employees and volunteers.

11.3.2 Acceptability of Insurers

All required insurance shall be provided by a company or companies lawfully authorized to do business in the jurisdiction in which the Project is located. Insurance shall be placed with insurers with an A.M. Best's rating of A-: VI or higher. This rating requirement may be waived for Worker's compensation coverage only.

If at any time an insurer issuing any such policy does not meet the minimum A.M. Best rating, the Contractor shall obtain a policy with an insurer that meets the A.M. Best rating and shall submit another certificate of insurance within 30 days.

11.3.3 Verification of Coverage

Contractor shall furnish the Owner with Certificates of Insurance reflecting proof of required coverage. The Certificates for each insurance policy are to be signed by a person authorized by that insurer to bind coverage on its behalf. The Certificates are to be received and approved by the Owner before Work commences and upon any contract renewal or insurance policy renewal thereafter. The Certificate Holder must be listed as follows:

State of Louisiana
University of Louisiana at Lafayette
PO Box 40197
Lafayette, LA 70504
Ref: Solicitation File No. _____

The Owner reserves the right to request complete certified copies of all required insurance policies at any time.

Upon failure of the Contractor to furnish, deliver and maintain required insurance, this contract, at the election of the Agency, may be suspended, discontinued, or terminated. Failure of the Contractor to purchase and/or maintain any required insurance shall not relieve the Contractor from any liability or indemnification under the contract.

If the Contractor does not meet the insurance requirements at policy renewal, at the option of the Owner, payment to the Contractor may be withheld until the requirements have been met, OR the Owner may pay the renewal premium and withhold such payment from any monies due the Contractor, OR the contract may be suspended or terminated for cause.

11.3.4 Subcontractors

Contractor shall include all subcontractors as insureds under its policies OR shall be responsible for verifying and maintaining the certificates provided by each subcontractor. Subcontractors shall be subject to all of the requirements stated herein. The Owner reserves the right to request copies of subcontractor's certificates at any time.

If Contractor does not verify subcontractors' insurance as described above, Owner has the right to withhold payments to the Contractor until the requirements have been met.

11.3.5 Worker's Compensation Indemnity

In the event Contractor is not required to provide or elects not to provide Worker's compensation coverage, the parties hereby agree the Contractor, its Owners, agents and employees shall have no cause of action against, and shall not assert a claim against, the state of Louisiana, its departments, agencies, agents and employees as an employer, whether pursuant to the Louisiana Worker's Compensation Act or otherwise, under any circumstance. The parties also hereby agree that the State of Louisiana, its departments, agencies, agents and employees shall in no circumstance be, or considered as, the employer or statutory employer of Contractor, its Owners, agents and employees. The parties further agree that Contractor is a wholly independent Contractor and is exclusively responsible for its employees, Owners, and agents. Contractor hereby agrees to protect, defend, indemnify and hold the State of Louisiana, its departments, agencies, agents and employees harmless from any such assertion or claim that may arise from the performance of this contract.

11.3.6 Indemnification/Hold Harmless Agreement

Contractor agrees to protect, defend, indemnify, save, and hold harmless, the State of Louisiana, all State Departments, Agencies, Boards and Commissions, its officers, agents, servants, employees and volunteers, from and against any and all claims, damages, expenses and liability arising out of injury or death to any person or the damage, loss or destruction of any property which may occur, or in any way grow out of, any act or omission of Contractor, its agents, servants and employees, or any and all costs, expenses and/or attorney fees incurred by Contractor as a result of any claims, demands, suits or causes of action, except those claims, demands, suits or causes of action arising out of the negligence of the State of Louisiana, all State Departments, Agencies, Boards, Commissions, its officers, agents, servants, employees and volunteers.

Contractor agrees to investigate, handle, respond to, provide defense for and defend any such claims, demands, suits or causes of action at its sole expense and agrees to bear all other costs and expenses related thereto, even if the claims, demands, suits, or causes of action are groundless, false or fraudulent. The State of Louisiana may, but is not required to, consult with the Contractor in the defense of claims, but this shall not affect the Contractor's responsibility for the handling and expenses of all claims.

11.4 PERFORMANCE AND PAYMENT BOND

11.4.1 The Owner shall have the right to require the Contractor to furnish bonds covering faithful performance of the Contract and payment of obligations arising thereunder as stipulated in bidding requirements or specifically required in the Contract Documents on the date of execution of the Contract.

11.4.2 Upon the request of any person or entity appearing to be a potential beneficiary of bonds covering payment of obligations arising under the Contract, the Contractor shall promptly furnish a copy of the bonds or shall authorize a copy to be furnished.

11.4.3 Recordation of Contract and Bond [La R.S. 38:2241 thru 38:2241.1]

The Owner shall require the Contractor to record within thirty (30) days the Contract Between Owner and Contractor and Performance and Payment Bond with the Clerk of Court in the Parish in which the Work is to be performed.

ARTICLE 12

UNCOVERING AND CORRECTION OF WORK

12.2 CORRECTION OF WORK

12.2.1 Before Substantial Completion

At the end of the paragraph, add the following sentences:

“If the Contractor fails to correct Work identified as defective within a thirty (30) day period, through no fault of the Designer, the Owner may hold the Contractor in default. If the Owner finds the Contractor in default, the Surety shall be notified. If within thirty (30) days after notification, the Surety has not corrected the nonconforming Work, through no fault of the Architect or Owner, the Owner may contract to have nonconforming Work corrected and hold the Surety and Contractor responsible for the cost, including architectural fees and other indirect costs. If the Surety fails to correct the Work within the stipulated time period and fails to meet its obligation to pay the costs, the Owner may elect not to accept bonds submitted in the future by the Surety. Finding the Contractor in default shall constitute a reason for disqualification of the Contractor from bidding on future state contracts.

12.2.2 After Substantial Completion

12.2.2.1 At the end of the paragraph delete the last sentence and add the following sentences:

“If the Contractor fails to correct nonconforming Work, or Work covered by warranties, within a thirty (30) day period, through no fault of the Architect or Owner, the Owner may hold the Contractor in default. If the Owner finds the Contractor is in default, the Surety shall be notified. If within thirty (30) days after notification, the Surety has not corrected the non-conforming or warranty Work, through no fault of the Architect or Owner, the Owner may contract to have the nonconforming or warranty Work corrected and hold the Surety responsible for the cost including architects fees and other indirect costs. Corrections by the Owner shall be in accordance with Section 2.4. If the Surety fails to correct the nonconforming or warranty Work within the stipulated time period and fails to meet its obligation to pay the costs, the Owner may not accept bonds submitted, in the future, by the Surety.”

ARTICLE 13

MISCELLANEOUS PROVISIONS

13.1 GOVERNING LAW

Delete all after the word “located”.

13.2 SUCCESSORS AND ASSIGNS

13.2.1 In the second sentence, delete “Except as ... 13.2.2”

Delete Section 13.2.2.

13.3 RIGHTS AND REMEDIES

Add the following Section 13.3.3:

13.3.3 The Nineteenth Judicial Court in and for the Parish of East Baton Rouge, State of Louisiana shall have sole jurisdiction and venue in any action brought under this contract.

13.4 TESTS AND INSPECTIONS

In Section 13.4.1, delete the second sentence and substitute the following:

The Contractor shall make arrangements for such tests, inspections and approvals with the Testing Laboratory provided by the Owner, and the Owner shall bear all related costs of tests, inspections and approvals.

Delete the last two sentences of Section 13.4.1.

13.5 INTEREST

Delete Section 13.5.

ARTICLE 14

TERMINATION OR SUSPENSION OF THE CONTRACT

14.1 TERMINATION BY THE CONTRACTOR

Delete Section 14.1.1.4.

In Section 14.1.3, after the word "profit," delete the words "on Work not executed" and substitute the following: "for Work completed prior to stoppage".

14.2 TERMINATION BY THE OWNER FOR CAUSE

Add the following Section:

14.2.1.5 failure to complete the punch list within the lien period as provided in 9.8.7.

14.2.3 Add the following sentence:

"Termination by the Owner shall not suspend assessment of liquidated damages against the Surety."

Add the following Section:

14.2.5 If an agreed sum of liquidated damages has been established, termination by the Owner under this Article shall not relieve the Contractor and/or Surety of his obligations under the liquidated damages provisions and the Contractor and/or Surety shall be liable to the Owner for per diem liquidated damages.

14.4 TERMINATION BY THE OWNER FOR CONVENIENCE

In Section 14.4.3, delete all after "incurred by reason of the termination," and add "along with reasonable profit on the Work not executed."

ARTICLE 15 CLAIMS AND DISPUTES

15.1 CLAIMS

Delete Section 15.1.2, Time Limit on Claims, (See La R.S. 38:2189, and 38:2189.1).

15.1.3.1 Add the following to the end of the paragraph:

"A Reservation of Rights and similar stipulations shall not be recognized under this contract as having any effect. A party must make a claim as defined herein within the time limits provided."

15.1.4.2 In the first sentence of the Section, delete "Initial Decision Maker's" and replace with "Architect's". In the second sentence of the Section, delete "the decision of the Initial Decision Maker" and replace with: "his/her decision".

Delete Section 15.1.6.2 and substitute the following:

15.1.6.2 If adverse weather conditions are the basis for a claim for additional time, the Contractor shall document that weather conditions had an adverse effect on the scheduled construction. An increase in the contract time due to weather shall not be cause for an increase in the contract sum. At the end of each month, the Contractor shall make one Claim for any adverse weather days occurring within the month. The Claim must be accompanied by sufficient documentation evidencing the adverse days and the impact on construction. Failure to make such Claim within twenty-one (21) days from the last day of the month shall prohibit any future claims for adverse days for that month. No additional adverse weather days shall be granted after the original or extended contract completion date, except those adverse weather days associated with a National Weather Service named storm or federally declared weather related disaster directly affecting the Project site.

Add the following Section:

15.1.6.3 The following are considered reasonably anticipated days of adverse weather on a monthly basis:

January	<u>11</u> days	July	<u>6</u> days
February	<u>10</u> days	August	<u>5</u> days
March	<u>8</u> days	September	<u>4</u> days
April	<u>7</u> days	October	<u>3</u> days
May	<u>5</u> days	November	<u>5</u> days
June	<u>6</u> days	December	<u>8</u> days

The Contractor shall ask for total adverse weather days. The Contractor's request shall be considered only for days over the allowable number of days stated above.

Note: Contract is on a calendar day basis.

15.2 INITIAL DECISION

15.2.1 In the second sentence, delete the word “will” and replace with: “shall always”.

In the second sentence, delete the phrase: “, unless otherwise indicated in the Agreement.”

In the third sentence, delete the word “mediation” and replace with: “litigation”.

At the end of the third sentence, add: “arising prior to the date final payment is due”.

Delete the fourth sentence.

15.2.5 In the middle of the first sentence, delete all after the phrase: “rejecting the Claim”.

In the second sentence, delete the phrase: “and the Architect, if the Architect is not serving as the Initial Decision Maker,”.

In the third sentence, delete all after: “binding on the parties” and add the following: “except that the Owner may reject the decision or suggest a compromise or both”.

Delete Section 15.2.6.

Delete Section 15.2.6.1.

15.3 MEDIATION

Delete Section 15.3.

15.4 ARBITRATION

Delete Section 15.4.

END OF SECTION

INSURANCE REQUIREMENTS

Contractor shall purchase, at its own cost and expense, and maintain for the duration of the Contract, insurance against claims for injuries to persons or damages to property which may arise from or in connection with the performance of the work hereunder by Contractor, its agents, representatives, employees, or subcontractors. The insurance shall be obtained from a company or companies lawfully authorized to do business in the State of Louisiana with a A.M. Best's rating of A-:VI or higher. Failure to comply with all terms of this section for the duration of the Contract places Contractor in breach of this Contract.

A. Minimum Scope of Insurance and Limits

1. Workers Compensation

Contractor shall be in compliance at all times with the Louisiana Workers' Compensation Law with respect to workers' compensation insurance or proper certification of self-insured status.

2. Commercial General Liability

Contractor shall maintain Commercial General Liability insurance, including Personal and Advertising Injury Liability, which coverage shall have a minimum limit per occurrence of \$1,000,000 and a minimum general aggregate of \$2,000,000. The Insurance Services Office (ISO) Commercial General Liability occurrence coverage form CG 00 01 (current form approved for use in Louisiana), or equivalent, is to be used in the policy. Claims-made form is unacceptable.

Additionally, if alcohol is served in the execution of this Contract, then Contractor shall maintain Liquor Liability coverage in the minimum amount of \$1,000,000 per occurrence.

Additionally, if valet parking is performed in the execution of this Contract, then Contractor shall maintain Garage Keepers Liability coverage in the minimum amount of \$1,000,000 per occurrence.

3. Automobile Liability

If a motor vehicle owned, hired, or rented by the Contractor is used in the performance of the Contract, Contractor shall maintain Automobile Liability Insurance, which coverage shall have a minimum combined single limit per occurrence of \$1,000,000. ISO form number CA 00 01 (current form approved for use in Louisiana), or equivalent, is to be used in the policy. This insurance shall include third-party bodily injury and property damage liability for owned, hired, and non-owned automobiles.

4. Professional Liability, Errors and Omissions, and Malpractice Insurance

If any of the following professionals provide services in the execution of the Contract, Contractor shall purchase and maintain Professional Liability Insurance, which coverage shall have minimum limits of \$1,000,000:

1. Medical Professionals, such as physicians, nurses, dentists, and pharmacists;
2. Architects and Engineers;
3. Attorneys;
4. Accountants and Professional Financial Advisors;
5. Real Estate Brokers and Appraisers;
6. Insurance Agents; and
7. Consultants.

Claims-made coverage for Professional Liability Insurance is acceptable. The date of the inception of the policy must be no later than the first date of the anticipated work under this Contract. It shall provide coverage for the duration of this Contract and shall have an expiration date no earlier than 30 days after the anticipated completion of the Contract. The policy shall provide an extended reporting period of at least 24 months, with full reinstatement of limits, from the expiration date of the policy, if policy is not renewed.

5. Cyber Liability Insurance

For Contracts in which the Contractor shall be granted access to electronic data belonging to the University or others, including but not limited to corporate confidential information (CCI), personal financial information (PII), personal health information (PHI), payment card information (PCI), and all personal student information (PSI) stored in electronic format, and for which there is a risk of electronic security breaches of this confidential data, including inadvertent release, hacking, viruses, improper destruction, etc., Cyber Liability insurance, including first-party costs, shall be required with a minimum limit per occurrence of \$1,000,000. Claims-made coverage is acceptable. The date of the inception of the policy must be no later than the first date of the anticipated work under this Contract. It shall provide coverage for the duration of this Contract and shall have an expiration date no earlier than 30 days after the anticipated completion of the Contract. The policy shall provide an extended reporting period of not less than 36 months from the expiration date of the policy, if the policy is not renewed. The policy shall not be cancelled for any reason, except non-payment of premium.

B. Other Insurance Provisions

Contractor shall either (i) require each subcontractor and vendor to procure and maintain all applicable insurance of the type and limits specified herein, or (ii) include all subcontractors as insureds under its policies.

Any deductibles or self-insured retentions must be declared to and accepted by University. Contractor shall be responsible for all deductibles and self-insured retentions. Any insurance or self-insurance maintained by University shall be excess and non-contributory of Contractor's insurance. Contractor's coverage shall contain no special limitations on the scope of protection afforded to University. Contractor's insurance shall be primary as respects

University, The Board of Supervisors for the University of Louisiana System ("Board"), and all of their respective officers, agents, employees, and volunteers.

Except for workers' compensation coverage, University and Board, and all of their respective officers, agents, employees, and volunteers, shall be named as an additional insured for the full occurrence and aggregate limits of the applicable insurance policies as regards negligence by Contractor. ISO Form CG 20 10 (current form approved for use in Louisiana), or equivalent, is to be used when applicable.

Contractor shall provide to University Certificates of Insurance ("Certificates") evidencing the foregoing coverage in advance of Contractor's delivery of goods and/or performance of work or services, and in all events, prior to any payment by University to Contractor. In addition to Certificates, Contractor shall submit to University the declarations page and the cancellation provisions for each insurance policy. University reserves the right to request complete certified copies of all required insurance policies at any time.

Certificates and all notices regarding coverage shall be addressed to: University of Louisiana at Lafayette

ATTN: Purchasing Department

P.O. Box 40197 Lafayette, LA 70504

Certificates of Insurance shall reflect that, to the fullest extent allowed by law, the insurer shall agree to waive all rights of subrogation against University, its officers, agents, employees, and volunteers for losses arising from work performed by the Contractor for University.

Coverage shall not be canceled, suspended, reduced, or voided by either Contractor or the insurer except after 30 days written notice has been given to University. Ten-day written notice of cancellation is acceptable for non-payment of premium. Notifications shall comply with the standard cancellation provisions in Contractor's policy.

Acceptance of goods or completed work by University, payment by University, failure of University to require proof of compliance, or University's acceptance of a non-compliant Certificate shall not release Contractor from its obligations under these insurance requirements. Failure of Contractor to purchase and/or maintain any required insurance shall not relieve Contractor from any liability or indemnification required by law or contract.

END OF SECTION

GENERAL REQUIREMENTS

The Contractor shall furnish and install all labor and material necessary to provide and install the complete portion of this contract, including all materials and equipment as shown on the plans. It is the intention of these specifications that all systems be furnished complete with whatever necessary items are required to produce a satisfactory installation in a working order. The Contractor shall be responsible for bringing to the attention of the Owner any shortcomings of the design, or thereby, shall be responsible in full to meet the conditions set forth, that being, the system is to be in a satisfactory working order.

All material shall be installed in accordance with the instructions of the manufacturers. The work shall be done in strict compliance with state and local ordinances governing this class of work. The prospective bidder shall visit the job site and become familiar with all existing conditions found at the site. The Contractor shall become acquainted with all existing factors and conditions which affect the work. Failure to do so shall not relieve meeting the responsibility to install the work correctly.

The Contractor shall protect the entire installation from injury on the Project until final acceptance. Failure to do so shall be sufficient cause for the Agent to reject any work.

CONSTRUCTION FORCE

The Contractor shall provide and maintain in full operation at all times during the performance of the contract a sufficient work crew to execute the work with dispatch. The Contractor shall provide a full time superintendent who shall be on the job during all working periods.

The Contractor shall be responsible for maintenance and repair of all equipment installed by him which fails due to substandard workmanship.

PARKING

Contractor shall be responsible for all fees for temporary campus parking permits. The Facility Management department shall request the permits through the UL Parking and Transit department. Contractor shall be required to display the permit on their vehicles at all times while on campus. Failure to do so may result in parking citation.

DEQ NOTIFICATION

The Contractor shall be responsible for the proper notification of the Department of Environmental Quality whenever demolition work is to be performed. Copies of the DEQ Notification Form AAC-2 and any additional correspondence with DEQ shall be copied to the University.

STANDARDS

All materials furnished under this contract shall be designed, constructed and rated in accordance with the latest applicable standards, and shall pass tests as recommended therein.

WORKMANSHIP AND MATERIALS

The workmanship shall conform to the best accepted construction practice. Should it become evident that during the course of construction that the items indicated on the plans, are for any reason undesirable, the Contractor shall immediately bring the situation to the attention of the Agent for a decision. The Contractor shall be responsible for installing the proper materials as described by the drawings and specifications.

All materials furnished for this Project shall be new, undamaged, and bear the label of the Underwriters' Laboratories, Inc. Deliver materials in manufacturer's original package and store on skids so that the materials are off the ground, and so that product labels are exposed for easy inspection.

The Bidder shall base the proposal on materials herein specified. Reference to specific manufacturers or trade names is not intended to limit or indicate preference to specific manufacturers, but to indicate a standard of quality. Written approval from the Agent is required on all substitutions prior to installations.

GUARANTEE

The Contractor shall guarantee new materials and workmanship for a minimum of one (1) full year after formal acceptance of the Project. The Contractor will replace defective material and repair all workmanship defects promptly, and absorb all costs.

This provision shall not override any other warranties that are specified herein.

CAMPUS SAFETY POLICY

Contractor shall adhere to the campus safety policy. Information regarding campus safety can be found on the UL Lafayette website at: <http://www.louisiana.edu/ehs>

LOUISIANA ONE CALL

UL Lafayette is a member in the Louisiana One Call system. At least 72 hours before digging anywhere on UL Lafayette property the contractor must call 1-800-272-3020 to verify the location of utilities.

EXISTING LANDSCAPING

Contractor is liable for any damages caused to the existing landscaping. All landscaping must be protected from root compaction and other physical damage. Contractor must provide three foot high orange construction fencing around the drip line of all trees within the construction site.

ASBESTOS

The contractor will not be required to interface with any asbestos containing material (ACM) during this Project. The State of Louisiana has conducted an asbestos survey of all buildings on the UL Lafayette campus. The results of the survey are compiled in management plans for each building. The management plans were assembled according to the requirements set forth in the Department of Environmental Quality Required Elements Index. These plans are available for review to anyone interested in the results. The plans are kept on file in the Reserve Reading Room of Edith Garland Dupre' Library.

COORDINATION OF WORK

The Contractor shall inform the Agent each day of his work location before proceeding to work, and each time the Contractor moves into a different area.

STORM WATER RUN OFF PROTECTION

Contractor shall protect the entire construction site from erosion due to storm water run-off. A retention barrier shall be constructed around the entire construction site perimeter to prevent erosion from infiltrating the storm water drainage system.

PAYMENT

The Contractor may invoice the Owner for work performed on a monthly basis. The work performed shall meet the approval of UL Lafayette. UL Lafayette shall process payment after verification of the invoice.

On Projects where a performance bond is specified, the University will withhold ten percent (10%) retainage from all payments for completed work. The retainage will be released to the contractor according to the procedures set forth in the "INSTRUCTIONS TO BIDDERS AND GENERAL CONDITIONS", section 10.

FINAL PAYMENT WILL NOT BE ISSUED UNTIL ALL UNIVERSITY KEYS HAVE BEEN RETURNED TO THE FACILITY MANAGEMENT OFFICE.

CLEAN-UP

The Contractor is responsible for the daily clean-up and disposal of all trash and construction debris relating to this Project. University dumpsters shall not be used for the disposal of debris. Should the Contractor dispose of any debris into University facilities, the cost of removal will be deducted from the University's final payment under this contract. Occupied areas (e.g.: Classrooms, Offices, Labs, etc.) shall be broom cleaned and vacuumed at the end of the work day to allow use of the room by the University. Debris and materials shall be removed from the rooms to allow use of the room by the University.

INDEMNIFICATION

The Contractor will indemnify and hold harmless the Owner and all of their agents and employees from and against all claims, damages, losses, and expenses including attorney's fees arising out of or resulting from operations under the Contract Documents by the Contractor, and subcontractor, anyone directly or indirectly employed by any of them, or anyone for whose acts any of them may be liable, which are caused in whole or in part by any error, omission, or act of any of them. If any and all claims against the Owner or any of their agents or employees by any employee of the Contractor, subcontractor, anyone directly or indirectly employed by any of them, or anyone for whose acts any of them may be liable,

the indemnification obligation of the Contractor under this article shall not be limited in any way by any limitation on the amount or type of damages, compensation or benefits payable by or for the Contractor or any subcontractor under Workmen's Compensation laws.

SPECIAL HEALTH & SAFETY RELATED CONTRACT CLAUSES:

ADDITIONAL CONTRACTOR REQUIREMENTS AND LIMITATION OF LIABILITY

It is expressly understood and agreed by the parties that:

(a) CONTRACTOR shall not visit or utilize the facilities of university if CONTRACTOR (i) experiences symptoms of COVID-19, including, without limitation, fever, cough, or shortness of breath, or (ii) has a suspected or diagnosed/confirmed case of COVID-19, and CONTRACTOR shall notify University immediately if he or she believes that any of the foregoing access/use restrictions may apply;

(b) University has taken certain steps to implement recommended guidance and protocols issued by the Centers for Disease Control ("CDC") and Louisiana Department of Health ("LDH") for slowing the transmission of COVID-19, including, without limitation, the access/use restrictions, and distancing and sanitization requirements set forth herein, and that University may revise its procedures at any time based on updated recommended guidance and protocols issued by the CDC and LDH and CONTRACTOR agrees to comply with University's current and revised procedures prior to utilizing the facilities of University;

(c) CONTRACTOR acknowledges and agrees that, due to the nature of the facilities and the services CONTRACTOR is providing to University, social distancing of six (6) feet per person may not always be possible and CONTRACTOR fully understands and appreciates both the known and potential dangers of utilizing the facilities of University and acknowledges that use thereof by CONTRACTOR may, despite University's reasonable efforts to mitigate such dangers, result in exposure to COVID-19, which could result in quarantine requirements, serious illness, disability, and/or death; and

(d) while University has instituted measures to sanitize common areas, CONTRACTOR shall be responsible for the daily sanitization of his/her personal workspace prior to and immediately preceding CONTRACTOR's use of the space. Under no circumstances shall University be liable to CONTRACTOR, or CONTRACTOR's personal representatives, assigns, heirs, and next of kin for any loss or damage, or any claim or demands on account of any property damage or any injury to, or an illness or the death of, the CONTRACTOR (or any person who may contract COVID-19, directly or indirectly, from the CONTRACTOR) whether caused by the negligence, active or passive, of University or otherwise while CONTRACTOR is in, upon, of about the premises or ay facilities or equipment therein of University.

FORCE MAJEURE

Notwithstanding anything to the contrary in this Agreement, neither party shall be liable to the other or be deemed to be in breach of this Agreement for any failure or delay in whole or partial performance under this Agreement when such failure or delay is caused in whole or in part by a "Force Majeure Event," which shall be defined as any event beyond the control of a party, including, but not limited to: labor disputes, strike, riot, vandalism, sabotage, terrorist act, war (whether declared or undeclared), inclement weather, flood (whether naturally occurring or manmade), tidal surge or tsunami, landslide, earthquake, fire (whether naturally occurring or manmade), explosion, power shortage or outage, fuel shortage, embargo, congestion or service failure, epidemic, or government regulation, proclamation, order, or action; and in each case not involving the fault or negligence of a party.

If any Force Majeure Event occurs affecting a party's performance under this Agreement, the affected party will give written notice within five (5) days of the occurrence of the Force Majeure Event to the other party and will use commercially reasonable efforts to minimize the impact of the Force Majeure Event. In the event of a Force Majeure Event resulting in a total or partial performance or service failure by either party, the University, in its sole discretion, may immediately terminate this Agreement. To the extent that services have been rendered and deemed acceptable by university, the service fee and other fees and charges payable by University hereunder shall be paid to the Contractor on a pro-rata basis. For those services which the Contractor is unable to perform under this Agreement as a result of such Force Majeure Event, University shall suspend all related payments until such services are restored.

END OF SECTION

Guidelines for Electronic Submission of Bids and Virtual Bid Openings

In keeping with the physical distancing guidelines associated with COVID-19 Public Health Emergency declared by Governor John Bel Edwards in Proclamation Numbers 41, 33, 32, 30, 27, and 25 JBE 2020, the Purchasing Department at the University of Louisiana at Lafayette is suspending in-person attendance at public bid openings. All tasks associated with sealed bids and corresponding bid openings will be completed electronically to the greatest extent possible.

BID SUBMISSIONS - USPS Mail bid submittal and In-person delivery of bids at the Purchasing Office ARE NO LONGER ACCEPTED.

This information applies to competitive sealed bids. Bidders shall submit proposals by EMAIL ONLY:

Electronic submittal: Bidders must submit bids electronically containing the mandatory information detailed in the bid specifications to be considered for the bid award. Without exception, the bid must be received at ULLafayetteBids@louisiana.edu on or before the date and time specified as its deadline. Bidders e-mailing their bids should allow sufficient time to ensure receipt of their proposal by the time specified. The timestamp recorded in the email acknowledgement shall be the official time of the submission.

The electronic submittal must contain the following information in the Subject Line:

File Number Company Name

LA Contractor's License No. (if applicable)

If the file size of the email submission exceeds server requirements, the email submission may be broken into smaller email messages with "Part 1 of __" included at the end of each original Subject Line (e.g. File No. 22200 – ABC Contractors, License No. 12345, Part 1 of 3).

The University assumes no responsibility for assuring accurate/complete e-mail transmission and receipt. The responsibility lies solely with each bidder to ensure their submission is received at the specified email address prior to the deadline.

Proposals received after the deadline, corrupted files, and incomplete submissions (e.g. Part 1 and Part 2 of 3 are received, but Part 3 is not) shall not be considered.

Bids advertised on LAPAC will show a solicitation file number formatted like 50011-ULLAF#####. It is only necessary to include the last five (5) digits of that number in the Subject Line.

Bids shall be submitted in .pdf format. Faxed submittals will not be accepted.

Bid Submissions for Public Works/Construction

In addition to the above, the following applies to Title 38 Public Works electronic bid submittals.

The bidder must sign electronically or submit a scanned signature on the Louisiana Uniform Public Works Bid Form.

As stated on the Louisiana Uniform Public Works Bid Form, a corporate resolution or written evidence of the authority of the person signing the bid for the public work as prescribed by LA R.S. 38:2212(B)(5) shall be enclosed, if your business is a corporation.

Bid submittal shall include security equal to 5% of bid. bid security shall be drawn in favor of the University of Louisiana at Lafayette and SHALL be in the form of a Bid Bond (Insurance Company), Bank Money Order*, Certified Check* or Cashier's Check*.

Bid security in the form of a Bank Money Order, Certified Check* or Cashier's Check* shall be accepted as bid security when submitting bids electronically if both the front and back of the bid security is scanned and included with the bid submission. The hard copy of that document must be received no later than three (3) business days after the bid opening at:

University of Louisiana at Lafayette Purchasing Office
PO Box 40197
Lafayette, LA 70504-0197

Louisiana Contractor's License Number shall be in the subject line of the bid for ALL bids greater than or equal to \$50,000.00. Bids for Plumbing/Electrical/Mechanical Work greater than or equal to \$10,000.00 shall disclose the Louisiana Contractor's License Number in the Subject Line.

Asbestos Abatement bids exceeding \$1.00 shall disclose the Louisiana Contractor's License Number in the Subject Line.

BID OPENINGS

Bid openings will continue to be open to the public, conducted virtually using Zoom. To ensure an accurate list of attendees, parties interested in viewing the opening must register for the meeting.

The link to register for each bid opening shall be provided with the Invitation to Bid. The link will be live at that time and will provide live audio access to the bid opening.

The Bid Opening Zoom meeting shall begin at the top of the hour listed in the specifications as the Bid Opening time. The actual opening of bids shall begin at five (5) past the hour to allow all attendees to log in and sign in properly. The public bid opening for this solicitation will take place on Tuesday, October 24, 2023 at 3:00PM on Zoom, which is available for viewing by registering at <https://ullafayette.zoom.us/meeting/register/tJkF-CgqTktHd34CF-yOYAX0n48NfGrpjD2>

Meeting ID: 949 8987 2779 Passcode: 351007

Requests for bid tabulations and solicitation inquiries should be directed to purchasing@louisiana.edu as listed in the solicitation/ITB.

END OF SECTION

VENDOR CHECK LIST**REQUIRED FORMS/ITEMS UPON BID SUBMISSION**

_____ Louisiana Uniform Public Works Bid Form

_____ Bid Security Equal to 5% of Bid

_____ Louisiana Contractor's License Number (If Applicable) in Subject Line of email

_____ If company bidding is a corporation, Corporate Resolution or written evidence of authority of person signing the bid for the public work (*See **annotation on Louisiana Public Work Bid Form.*)

REQUIRED FORMS AFTER BID OPENING/UPON BID AWARD

_____ Attestation Affidavit (ALL BIDDERS, WITHIN 10 DAYS OF BID OPENING)

_____ Non-Collusion Affidavit (LOW BIDDER, WITHIN 10 DAYS OF REQUEST)

_____ Disclosure of Ownership Affidavit (LOW BIDDER, WITHIN 10 DAYS OF REQUEST)

_____ Performance and Payment Bond (LOW BIDDER, WITHIN 10 DAYS OF REQUEST)

_____ Certificate of Insurance

_____ Certificate of Recordation of Contract and Bonds

_____ Clear Lien Certificate

CONTACT INFORMATION

ELECTRONIC BID SUBMISSIONS (ONLY) *Do not email questions about the bid to this email address.*

ULLafayetteBids@louisiana.edu

Be sure to include the solicitation number in the subject line.

Do not send your submission to any other University email address.

QUESTIONS/CONCERNS ABOUT SPECIFICATIONS

purchasing@louisiana.edu mary.borel@louisiana.edu

Do not email bid submissions to either of these addresses.

To contact Purchasing by phone: 337.482.9051.

CAMPUS DELIVERIES

The campus is not fully open for receiving deliveries by courier at this time. Please send samples or other associated documents via US Mail only when a hard copy is requested or deemed necessary. The UL- Lafayette Post Office (located inside the Student Union) will accept packages with proper postage to place in the Purchasing Department's mailbox. The phone number is 337.482.6113.

LOUISIANA UNIFORM PUBLIC WORK BID FORM

TO: University of Louisiana at Lafayette
Purchasing Office, Martin Hall Room 123
104 University Circle
PO Box 40197
Lafayette, LA 70504

BID FOR: NIRC – BUILDING 30, 3RD FLOOR RENOVATION FOR (IT)
BLD: BUILDING 30, 3RD FL
File No. 24205

The undersigned bidder hereby declares and represents that she/he: a) has carefully examined and understands the Bidding Documents, b) has not received, relied on, or based his bid on any verbal instructions contrary to the Bidding Documents or any addenda, c) has personally inspected and is familiar with the Project site, and hereby proposes to provide all labor, materials, tools, appliances and facilities as required to perform, in a workmanlike manner, all work and services for the construction and completion of the referenced Project, all in strict accordance with the Bidding Documents prepared by:

University of Louisiana at Lafayette and dated: September 2023
(Owner to provide name of entity preparing bidding documents.)

Bidder must acknowledge all addenda. The Bidder acknowledges receipt of the following ADDENDA: (Enter the number the Designer has assigned to each of the addenda that the Bidder is acknowledging) _____

TOTAL BASE BID: For all work required by the Bidding Documents (including any and all unit prices designated "Base Bid"* but not alternates) the sum of:

_____ Dollars (\$ _____)

ALTERNATES: For any and all work required by the Bidding Documents for Alternates including any and all unit prices designated as alternates in the unit price description.

Alternate No. 1: (Owner to provide description of alternate and state whether add or deduct) for the lump sum of:

_____ N/A _____ Dollars (\$ _____ N/A _____)

Alternate No. 2: (Owner to provide description of alternate and state whether add or deduct) for the lump sum of:

_____ N/A _____ Dollars (\$ _____ N/A _____)

Alternate No. 3: (Owner to provide description of alternate and state whether add or deduct) for the lump sum of:

_____ N/A _____ Dollars (\$ _____ N/A _____)

NAME OF BIDDER: _____

ADDRESS OF BIDDER: _____

LOUISIANA CONTRACTOR'S LICENSE NUMBER: _____

NAME OF AUTHORIZED SIGNATORY OF BIDDER: _____

TITLE OF AUTHORIZED SIGNATORY OF BIDDER: _____

SIGNATURE OF AUTHORIZED SIGNATORY OF BIDDER**: _____

DATE: _____

* The Unit Price Form shall be used if the contract includes unit prices. Otherwise, it is not required and need not be included with the form. The number of unit prices that may be included is not limited and additional sheets may be included if needed.

** A CORPORATE RESOLUTION OR WRITTEN EVIDENCE of the authority of the person signing the bid for the public work as prescribed by LA R.S. 38:2212(B)(5). BID SECURITY in the form of a bid bond, certified check or cashier's check as prescribed by LA RS 38:2218(A) attached to and made a part of this bid.

ATTESTATIONS AFFIDAVIT – PAGE 1 OF 2

NIRC – BUILDING 30, 3RD FLOOR RENOVATION FOR (IT)**24205**

Name of Project

Project No.

STATE OF LOUISIANAPARISH OF IBERIAATTESTATIONS AFFIDAVIT

Before me, the undersigned notary public, duly commissioned and qualified in and for the parish and state aforesaid, personally came and appeared Affiant, who after being duly sworn, attested as follows:

LA. R.S. 38:2227 PAST CRIMINAL CONVICTIONS OF BIDDERS

- A. No sole proprietor or individual partner, incorporator, director, manager, officer, organizer, or member who has a minimum of a ten percent (10%) ownership in the bidding entity named below has been convicted of, or has entered a plea of guilty or nolo contendere to any of the following state crimes or equivalent federal crimes:

- | | |
|---------------------------------------|-----------------------------------|
| (a) Public bribery (R.S. 14:118) | (c) Extortion (R.S. 14:66) |
| (b) Corrupt influencing (R.S. 14:120) | (d) Money laundering (R.S. 14:23) |

- B. Within the past five years from the Project bid date, no sole proprietor or individual partner, incorporator, director, manager, officer, organizer, or member who has a minimum of a ten percent (10%) ownership in the bidding entity named below has been convicted of, or has entered a plea of guilty or nolo contendere to any of the following state crimes or equivalent federal crimes, during the solicitation or execution of a contract or bid awarded pursuant to the provisions of Chapter 10 of Title 38 of the Louisiana Revised Statutes:

- | | |
|--|--|
| (a) Theft (R.S. 14:67) | (f) Bank fraud (R.S. 14:71.1) |
| (b) Identity Theft (R.S. 14:67.16) | (g) Forgery (R.S. 14:72) |
| (c) Theft of a business record
(R.S.14:67.20) | (h) Contractors; misapplication of
payments (R.S. 14:202) |
| (d) False accounting (R.S. 14:70) | (i) Malfeasance in office (R.S. 14:134) |
| (e) Issuing worthless checks
(R.S. 14:71) | |

LA.R.S.38:2212.10 Verification of Employees

A. At the time of bidding, Appearer is registered and participates in a status verification system to verify that all new hires in the state of Louisiana are legal citizens of the United States or are legal aliens.

B. If awarded the contract, Appearer shall continue, during the term of the contract, to utilize a status verification system to verify the legal status of all new employees in the state of Louisiana.

C. If awarded the contract, Appearer shall require all subcontractors to submit to it a sworn affidavit verifying compliance with Paragraphs (A) and (B) of this Subsection.

ATTESTATIONS AFFIDAVIT – PAGE 2 OF 2

NIRC – BUILDING 30, 3RD FLOOR RENOVATION FOR (IT) 24205
Name of Project Project No.

LA. R.S. 23:1726(B) Certification Regarding Unpaid Workers Compensation Insurance

A.R.S. 23:1726 prohibits any entity against whom an assessment under Part X of Chapter 11 of Title 23 of the Louisiana Revised Statutes of 1950 (Alternative Collection Procedures & Assessments) is in effect, and whose right to appeal that assessment is exhausted, from submitting a bid or proposal for or obtaining any contract pursuant to Chapter 10 of Title 38 of the Louisiana Revised Statutes of 1950 and Chapters 16 and 17 of Title 39 of the Louisiana Revised Statutes of 1950.

B. By signing this bid /proposal, Affiant certifies that no such assessment is in effect against the bidding / proposing entity.

NAME OF BIDDER

NAME OF AUTHORIZED SIGNATORY OF BIDDER

DATE

TITLE OF AUTHORIZED SIGNATORY OF BIDDER

SIGNATURE OF AUTHORIZED
SIGNATORY OF BIDDER/AFFIANT

Sworn to and subscribed before me by Affiant on the ____ day of _____, 20__.

Notary Public

NON-COLLUSION AFFIDAVIT

STATE OF LOUISIANA

[X] PARISH OF IBERIA

[] COUNTY OF _____

AFFIDAVIT ATTESTING THAT
PUBLIC CONTRACT WAS NOT NOR
WILL BE SECURED
THROUGH EMPLOYMENT OR PAYMENT OF SOLICITOR

KNOW ALL MEN BY THESE PRESENCE, that a public contract is contemplated between

University of Louisiana at Lafayette and

represented by (print or type) _____ attests that s/he is empowered and authorized to execute said documents.

FURTHER, (signature) _____, who being duly sworn, does depose and attest that:

- 1) Affiant employed no person, corporation, firm, association, or other organization, either directly or indirectly, to secure the public contract under which he received payment, other than persons regularly employed by the affiant whose services in connection with the construction, alteration or demolition of the public building or Project or in securing the public contract wherein the regular course of their duties for affiant; and
- 2) That no part of the contract price received by affiant was paid or will be paid to any person, Corporation, firm, association, or other organization for soliciting the contract, other than the payment of their normal compensation to persons regularly employed by the affiant whose services in connection with the construction, alteration or demolition of the public building or Project were in the regular course of their duties for affiant.

BEFORE ME, the representing authority, personally appeared, who being duly sworn, deposes and states that the above is true and correct in all respects recited.

SWORN TO AND SUBSCRIBED before me, this _____ day of _____, 20_____.

Notary Public

**ATTACHMENT A
TO FOLLOW
IMMEDIATELY**

INDEX

DIVISION 01 - GENERAL REQUIREMENTS

N/A

DIVISION 02 – EXISTING CONDITIONS

N/A

DIVISION 03 – CONCRETE

N/A

DIVISION 04 – MASONRY

N/A

DIVISION 05 – METALS

N/A

DIVISION 06 – WOOD AND PLASTICS, AND COMPOSITES

N/A

DIVISION 07 - THERMAL AND MOISTURE PROTECTION

07 92 00 Joint Sealants

DIVISION 08 – OPENINGS

08 11 13 Hollow Metal Doors and Frames

08 71 00 Door Hardware

DIVISION 9 – FINISHES

09 22 16 Non-Structural Metal Framing

09 29 00 Gypsum Board

09 51 13 Acoustical Panel Ceilings

09 65 13 Resilient Base and Accessories

09 91 23 Interior Painting

DIVISION 10 – SPECIALTIES

10 44 16 Fire Extinguishers

DIVISION 11 – EQUIPMENT

N/A

DIVISION 12 – FURNISHINGS

N/A

DIVISION 13 – SPECIAL CONSTRUCTION

N/A

DIVISION 21 - FIRE PROTECTION

N/A

DIVISION 22 - PLUMBING

N/A

DIVISION 23 - HEATING, VENTILATING, AND AIR CONDITIONING

- 23 05 00 General Provisions for HVAC
- 23 05 03 Basic Material and Methods for HVAC
- 23 05 93 Testing, Adjusting and Balancing for HVAC
- 23 07 00 Mechanical Insulation
- 23 09 00 Temperature Controls for HVAC
- 23 30 00 Air Distribution for HVAC
- 23 70 00 Air Conditioning for HVAC

DIVISION 26 – ELECTRICAL

- 26 01 00 Electrical General Conditions
- 26 05 00 Basic Electrical Materials and Methods
- 26 05 19 Conductors and Cables
- 26 05 26 Grounding and Bonding
- 26 05 33 Raceways and Boxes
- 26 05 53 Electrical Identification
- 26 09 23 Lighting Control Devices
- 26 24 16 Panelboards
- 26 27 26 Wiring Devices
- 26 28 16 Enclosed Switches and Circuit Breakers
- 26 43 13 Transient Voltage Suppression
- 26 51 19 Led Interior Lighting

DIVISION 27 – COMMUNICATIONS

N/A

DIVISION 28 – ELECTRONIC SAFETY AND SECURITY

N/A

Preface

This introduction shall augment the contract documents for this project. All Contractors shall become familiar with all documents which comprise the Contract Documents, prior to bidding. It is important to read and become thoroughly familiar with all documents and understand their individual and collective importance. It is vital that a Contractor visit the Project site, thoroughly study the existing conditions, compare visual observations with field measurements, reference the Contract Documents, and use all as a basis for bidding.

After the contractor's bid is received neither the Owner nor Architect shall entertain extra compensation to the Contractor for claims of insufficient information in the Contract Documents. It is the sole responsibility of the bidding Contractor to visit the project site, thoroughly review all Contract Documents, including Drawings, Specifications, referenced information and standards, and Addenda prior to bidding. He shall obtain written clarifications and /or additional information needed to completely understand the Project scope prior to bidding. This does not imply that the Contractor or Architect is responsible for unexpected, concealed conditions, which cannot be verified without excavation or demolition.

The Contractor for this Project shall abide by the requirements of the Contract Documents, including Shop Drawings, Submittals, and other documents which become part of this Contract once submitted to the Architect.

Non-compliance with any of the Contract Documents could cause termination of the Contract by the Owner, in the manner set forth in the General Conditions.

No document in the Contract Documents shall be considered lightly, extraneous, non-applicable, standard, or unimportant. If conflicts occur between different areas in the drawings, different sections in the specifications or between drawings and specifications the most stringent requirements shall supersede all others.

SECTION 07 92 00 – JOINT SEALANTS

PART 1 - GENERAL

1.1 RELATED DOCUMENTS

- A. Drawings and general provisions of the Contract, including General and Supplementary Conditions and Division 01 Specification Sections, apply to this Section.

1.2 SUMMARY

A. Section Includes:

1. Silicone joint sealants.
2. Urethane joint sealants.
3. Latex joint sealants.
4. Acoustical joint sealants.

B. Related Sections:

1. Section 088000 "Glazing" for glazing sealants.
2. Section 092900 "Gypsum Board" for sealing perimeter joints.
3. Section 095113 "Acoustical Panel Ceilings" for sealing edge moldings at perimeters with acoustical sealant.

1.3 PRECONSTRUCTION TESTING

- A. Preconstruction Compatibility and Adhesion Testing: Submit to joint-sealant manufacturers, for testing indicated below, samples of materials that will contact or affect joint sealants.
 1. Use ASTM C 1087 or manufacturer's standard test method to determine whether priming and other specific joint preparation techniques are required to obtain rapid, optimum adhesion of joint sealants to joint substrates.
 2. Schedule sufficient time for testing and analyzing results to prevent delaying the Work.
 3. Testing will not be required if joint-sealant manufacturers submit joint preparation data that are based on previous testing, not older than 24 months, of sealant products for adhesion to, and compatibility with, joint substrates and other materials matching those submitted.

1.4 ACTION SUBMITTALS

- A. Product Data: For each joint-sealant product indicated.
- B. Samples for Initial Selection: Manufacturer's color charts consisting of strips of cured sealants showing the full range of colors available for each product exposed to view.
- C. Joint-Sealant Schedule: Include the following information:
 1. Joint-sealant application, joint location, and designation.
 2. Joint-sealant manufacturer and product name.

3. Joint-sealant formulation.
4. Joint-sealant color.

1.5 INFORMATIONAL SUBMITTALS

- A. Product Certificates: For each kind of joint sealant and accessory, from manufacturer.
- B. Product Test Reports: Based on evaluation of comprehensive tests performed by a qualified testing agency, indicating that sealants comply with requirements.
- C. Preconstruction Compatibility and Adhesion Test Reports: From sealant manufacturer, indicating the following:
 1. Materials forming joint substrates and joint-sealant backings have been tested for compatibility and adhesion with joint sealants.
 2. Interpretation of test results and written recommendations for primers and substrate preparation needed for adhesion.
- D. Warranties: Sample of special warranties.

1.6 QUALITY ASSURANCE

- A. Source Limitations: Obtain each kind of joint sealant from single source from single manufacturer.

1.7 PROJECT CONDITIONS

- A. Do not proceed with installation of joint sealants under the following conditions:
 1. When ambient and substrate temperature conditions are outside limits permitted by joint-sealant manufacturer or are below 40 deg F (5 deg C).
 2. When joint substrates are wet.
 3. Where joint widths are less than those allowed by joint-sealant manufacturer for applications indicated.
 4. Where contaminants capable of interfering with adhesion have not yet been removed from joint substrates.

1.8 WARRANTY

- A. Special Installer's Warranty: Manufacturer's standard form in which Installer agrees to repair or replace joint sealants that do not comply with performance and other requirements specified in this Section within specified warranty period.
 1. Warranty Period: Two years from date of Substantial Completion.
- B. Special Manufacturer's Warranty: Manufacturer's standard form in which joint-sealant manufacturer agrees to furnish joint sealants to repair or replace those that do not comply with performance and other requirements specified in this Section within specified warranty period.
 1. Warranty Period: One year from date of Substantial Completion.

- C. Special warranties specified in this article exclude deterioration or failure of joint sealants from the following:
 - 1. Movement of the structure caused by structural settlement or errors attributable to design or construction resulting in stresses on the sealant exceeding sealant manufacturer's written specifications for sealant elongation and compression.
 - 2. Disintegration of joint substrates from natural causes exceeding design specifications.
 - 3. Mechanical damage caused by individuals, tools, or other outside agents.
 - 4. Changes in sealant appearance caused by accumulation of dirt or other atmospheric contaminants.

PART 2 - PRODUCTS

2.1 MATERIALS, GENERAL

- A. Compatibility: Provide joint sealants, backings, and other related materials that are compatible with one another and with joint substrates under conditions of service and application, as demonstrated by joint-sealant manufacturer, based on testing and field experience.
- B. Liquid-Applied Joint Sealants: Comply with ASTM C 920 and other requirements indicated for each liquid-applied joint sealant specified, including those referencing ASTM C 920 classifications for type, grade, class, and uses related to exposure and joint substrates.
 - 1. Suitability for Immersion in Liquids. Where sealants are indicated for Use I for joints that will be continuously immersed in liquids, provide products that have undergone testing according to ASTM C 1247. Liquid used for testing sealants is deionized water, unless otherwise indicated.
- C. Colors of Exposed Joint Sealants: As selected by Architect from manufacturer's full range.

2.2 SILICONE JOINT SEALANTS

- A. Single-Component, Nonsag, Neutral-Curing Silicone Joint Sealant: ASTM C 920, Type S, Grade NS, Class 100/50, for Use NT.(Use on vertical joints in wet areas.)
 - 1. Products: Subject to compliance with requirements, available products that may be incorporated into the Work include, but are not limited to, the following]:
 - a. Dow Corning Corporation; 790.
 - b. GE Advanced Materials - Silicones; SilPruf LM SCS2700.
 - c. Sika Corporation, Construction Products Division; SikaSil-C990.
- B. Single-Component, Nonsag, Neutral-Curing Silicone Joint Sealant: ASTM C 920, Type S, Grade NS, Class 25, for Use NT.
 - 1. Products: Subject to compliance with requirements, available products that may be incorporated into the Work include, but are not limited to, the following:
 - a. Dow Corning Corporation; 799.
 - b. GE Advanced Materials - Silicones; UltraGlaze SSG4000.

2.3 URETHANE JOINT SEALANTS

- A. Single-Component, Nonsag, Urethane Joint Sealant: ASTM C 920, Type S, Grade NS, Class 25, for Use NT or T.
 - 1. Products: Subject to compliance with requirements, available products that may be incorporated into the Work include, but are not limited to, the following]:
 - a. BASF Building Systems; Sonolastic NP1.
 - b. Sika Corporation, Construction Products Division; Sikaflex - 1a.
- B. Immersible, Single-Component, Nonsag, Traffic-Grade, Urethane Joint Sealant: ASTM C 920, Type S, Grade NS, Class 25, for Uses T and I.
 - 1. Products: Subject to compliance with requirements, available products that may be incorporated into the Work include, but are not limited to, the following]:
 - a. BASF Building Systems; Sonolastic NP1.
 - b. Sika Corporation, Construction Products Division; Sikaflex - 1a.

2.4 LATEX JOINT SEALANTS

- A. Latex Joint Sealant: Acrylic latex or siliconized acrylic latex, ASTM C 834, Type OP, Grade NF.
 - 1. Products: Subject to compliance with requirements, available products that may be incorporated into the Work include, but are not limited to, the following]:
 - a. BASF Building Systems; Sonolac.
 - b. Pecora Corporation; AC-20+.
 - c. Tremco Incorporated; Tremflex 834.

2.5 ACOUSTICAL JOINT SEALANTS

- A. Acoustical Joint Sealant: Manufacturer's standard non-sag, paintable, non-staining latex sealant complying with ASTM C 834. Product effectively reduces airborne sound transmission through perimeter joints and openings in building construction as demonstrated by testing representative assemblies according to ASTM E 90.
 - 1. Products: Subject to compliance with requirements, available products that may be incorporated into the Work include, but are not limited to, the following]:
 - a. Pecora Corporation; AC-20 FTR
 - b. USG Corporation; SHEETROCK Acoustical Sealant.

2.6 JOINT SEALANT BACKING

- A. General: Provide sealant backings of material that are non-staining; are compatible with joint substrates, sealants, primers, and other joint fillers; and are approved for applications

indicated by sealant manufacturer based on field experience and laboratory testing.

- B. Cylindrical Sealant Backings: ASTM C 1330, Type C (closed-cell material with a surface skin) Type B (bicellular material with a surface skin) or any of the preceding types, as approved in writing by joint-sealant manufacturer for joint application indicated, and of size and density to control sealant depth and otherwise contribute to producing optimum sealant performance.
- C. Bond-Breaker Tape: Polyethylene tape or other plastic tape recommended by sealant manufacturer for preventing sealant from adhering to rigid, inflexible joint-filler materials or joint surfaces at back of joint. Provide self-adhesive tape where applicable.

2.7 MISCELLANEOUS MATERIALS

- A. Primer: Material recommended by joint-sealant manufacturer where required for adhesion of sealant to joint substrates indicated, as determined from preconstruction joint-sealant-substrate tests and field tests.
- B. Cleaners for Nonporous Surfaces: Chemical cleaners acceptable to manufacturers of sealants and sealant backing materials, free of oily residues or other substances capable of staining or harming joint substrates and adjacent nonporous surfaces in any way and formulated to promote optimum adhesion of sealants to joint substrates.
- C. Masking Tape: Non-staining, nonabsorbent material compatible with joint sealants and surfaces adjacent to joints.

PART 3 - EXECUTION

3.1 EXAMINATION

- A. Examine joints indicated to receive joint sealants, with Installer present, for compliance with requirements for joint configuration, installation tolerances, and other conditions affecting joint- sealant performance.
- B. Proceed with installation only after unsatisfactory conditions have been corrected.

3.2 PREPARATION

- A. Surface Cleaning of Joints: Clean out joints immediately before installing joint sealants to comply with joint-sealant manufacturer's written instructions and the following requirements:
 - 1. Remove all foreign material from joint substrates that could interfere with adhesion of joint sealant, including dust, paints (except for permanent, protective coatings tested and approved for sealant adhesion and compatibility by sealant manufacturer), old joint sealants, oil, grease, waterproofing, water repellents, water, surface dirt, and frost.
 - 2. Clean, porous joint substrate surfaces by brushing, grinding, mechanical abrading, or a combination of these methods to produce a clean, sound substrate capable of developing optimum bond with joint sealants. Remove loose particles remaining after cleaning operations above by vacuuming or blowing out joints with oil-free

compressed air. Porous joint substrates include the following:

- a. Concrete.
 - b. Masonry.
 - c. Unglazed surfaces of ceramic tile.
3. Remove laitance and form-release agents from concrete.
 4. Clean nonporous joint substrate surfaces with chemical cleaners or other means that do not stain, harm substrates, or leave residues capable of interfering with adhesion of joint sealants. Nonporous joint substrates include the following:
 - a. Metal.
 - b. Glass.
 - c. Glazed surfaces of ceramic tile.
- B. Joint Priming: Prime joint substrates where recommended by joint-sealant manufacturer or as indicated by preconstruction joint-sealant-substrate tests or prior experience. Apply primer to comply with joint-sealant manufacturer's written instructions. Confine primers to areas of joint- sealant bond; do not allow spillage or migration onto adjoining surfaces.
- C. Masking Tape: Use masking tape where required to prevent contact of sealant or primer with adjoining surfaces that otherwise would be permanently stained or damaged by such contact or by cleaning methods required to remove sealant smears. Remove tape immediately after tooling without disturbing joint seal.

3.3 INSTALLATION OF JOINT SEALANTS

- A. General: Comply with joint-sealant manufacturer's written installation instructions for products and applications indicated, unless more stringent requirements apply.
- B. Sealant Installation Standard: Comply with recommendations in ASTM C 1193 for use of joint sealants as applicable to materials, applications, and conditions indicated.
- C. Install sealant backings of kind indicated to support sealants during application and at position required to produce cross-sectional shapes and depths of installed sealants relative to joint widths that allow optimum sealant movement capability.
1. Do not leave gaps between ends of sealant backings.
 2. Do not stretch, twist, puncture, or tear sealant backings.
 3. Remove absorbent sealant backings that have become wet before sealant application and replace them with dry materials.
- D. Install bond-breaker tape behind sealants where sealant backings are not used between sealants and backs of joints.
- E. Install sealants using proven techniques that comply with the following and at the same time backings are installed:
1. Place sealants so they directly contact and fully wet joint substrates.
 2. Completely fill recesses in each joint configuration.
 3. Produce uniform, cross-sectional shapes and depths relative to joint widths that

allow optimum sealant movement capability.

- F. Tooling of Nonsag Sealants: Immediately after sealant application and before skinning or curing begins, tool sealants according to requirements specified in subparagraphs below to form smooth, uniform beads of configuration indicated; to eliminate air pockets; and to ensure contact and adhesion of sealant with sides of joint.
 - 1. Remove excess sealant from surfaces adjacent to joints.
 - 2. Use tooling agents that are approved in writing by sealant manufacturer and that do not discolor sealants or adjacent surfaces.
 - 3. Provide concave joint profile per Figure 8A in ASTM C 1193, unless otherwise indicated.
 - a. Use masking tape to protect surfaces adjacent to recessed tooled joints.
- G. Acoustical Sealant Installation: At sound-rated assemblies and elsewhere as indicated, seal construction at perimeters, behind control joints, and at openings and penetrations with a continuous bead of acoustical sealant. Install acoustical sealant at both faces of partitions at perimeters and through penetrations. Comply with ASTM C 919 and with manufacturer's written recommendations.

3.4 CLEANING

- A. Clean off excess sealant or sealant smears adjacent to joints as the Work progresses by methods and with cleaning materials approved in writing by manufacturers of joint sealants and of products in which joints occur.

3.5 PROTECTION

- A. Protect joint sealants during and after curing period from contact with contaminating substances and from damage resulting from construction operations or other causes so sealants are without deterioration or damage at time of Substantial Completion. If, despite such protection, damage or deterioration occurs, cut out and remove damaged or deteriorated joint sealants immediately so installations with repaired areas are indistinguishable from original work.

END OF SECTION 07 92 00

SECTION 08 11 13 – HOLLOW METAL DOOR FRAMES

PART 1 - GENERAL

1.1 RELATED DOCUMENTS

- A. Drawings and general provisions of the Contract, including General and Supplementary Conditions, apply to this Section.

1.2 SUMMARY

- A. Section includes:
 - 1. Interior standard door and hollow-metal frames.
 - 2. Exterior
- B. Related Requirements:
 - 1. Section 087100 "Door Hardware" for door hardware for hollow metal door frames.

1.3 DEFINITIONS

- A. Minimum Thickness: Minimum thickness of base metal without coatings according to NAAMM-HMMA 803 or SDI A250.8.

1.4 COORDINATION

- A. Coordinate anchorage installation for hollow-metal frames. Furnish setting drawings, templates, and directions for installing anchorages, including sleeves, concrete inserts, anchor bolts, and items with integral anchors. Deliver such items to Project site in time for installation.

1.5 ACTION SUBMITTALS

- A. Product Data: For each type of product.
 - 1. Include construction details, material descriptions, core descriptions, fire-resistance ratings, and finishes.
- B. Shop Drawings: Include the following:
 - 1. Frame details for each frame type, including dimensioned profiles and metal thicknesses.
 - 2. Locations of reinforcement and preparations for hardware.
 - 3. Details of each different wall opening condition.
 - 4. Details of anchorages, joints, field splices, and connections.
 - 5. Details of accessories.

6. Details of conduit and preparations for power, signal, and control systems.

C. Schedule: Provide a schedule of hollow-metal work prepared by or under the supervision of supplier, using same reference numbers for details and openings as those on Drawings. Coordinate with final Door Hardware Schedule.

1.6 DELIVERY, STORAGE, AND HANDLING

A. Deliver hollow-metal work palletized, packaged, or crated to provide protection during transit and Project-site storage. Do not use non-vented plastic.

1. Provide additional protection to prevent damage to factory-finished units.

B. Store hollow-metal work vertically under cover at Project site with head up. Place on minimum 4-inch- (102-mm-) high wood blocking. Provide minimum 1/4-inch (6-mm) space between each stacked door to permit air circulation.

PART 2 - PRODUCTS

2.1 MANUFACTURERS

A. Manufacturers: Subject to compliance with requirements, available manufacturers offering products that may be incorporated into the Work include, but are not limited to, the following:

1. CDF
2. Amweld International, LLC.
3. Ceco Door Products; an Assa Abloy Group company.
4. Curries Company; an Assa Abloy Group company.
5. MPI Group, LLC (The).
6. Republic Doors and Frames.
7. Steelcraft; an Ingersoll-Rand company.

B. Source Limitations: Obtain hollow-metal work from single source from single manufacturer.

2.2 REGULATORY REQUIREMENTS

A. Fire-Rated Assemblies: Complying with NFPA 80 and listed and labeled by a qualified testing agency acceptable to authorities having jurisdiction for fire-protection ratings indicated, based on testing at positive pressure according to NFPA 252 or UL 10C.

1. Smoke- and Draft-Control Assemblies: Provide an assembly with gaskets listed and labeled for smoke and draft control by a qualified testing agency acceptable to authorities having jurisdiction, based on testing according to UL 1784 and installed in compliance with NFPA 105.

2.3 INTERIOR STANDARD HOLLOW METAL FRAMES

A. Construct interior door frames to comply with the standards indicated for materials, fabrication, hardware locations, hardware reinforcement, tolerances, and clearances, and

as specified.

B. Standard-Duty Doors and Frames:

1. Doors:
 - a. Physical Performance: Level A according to SDI A250.4.
 - b. Type: As indicated in the Door and Frame Schedule on Drawings.
 - c. Thickness: 1-3/4 inches.
 - d. Edge Construction: Manufacturer's standard beveled or square edges.
 - e. Core: Manufacturer's standard insulated core.
2. Standard Door Frames:
 - a. Materials: Uncoated, steel sheet, minimum thickness of 0.053 inch (1.3 mm).
 - b. Construction: Knock-down frames.
3. Exposed Finish: Factory Primed.
4. General: Comply with ANSI/SDI A250.8 and with details indicated for type and profile.

C. Hardware Reinforcement: Fabricate according to ANSI/SDI A250.6 with reinforcement plates from same material as frames.

2.4 EXTERIOR STANDARD STEEL DOORS AND FRAMES

A. Extra-Heavy-Duty Doors and Frames: ANSI/SDI A250.8, Level 3; ANSI/SDI A250.4, Level A. At Exterior Door Locations.

1. Doors:
 - a. Type: As indicated in the Door and Frame Schedule.
 - b. Thickness: 1-3/4 inches (44.5 mm).
 - c. Face: Metallic-coated steel sheet, minimum thickness of 0.053 inch (1.3 mm), with minimum A60 (ZF180) coating.
 - d. Edge Bevel: Provide manufacturer's standard beveled or square edges.
 - e. Top Edge Closures: Close top edges of doors with flush closures of same material as face sheets. Seal joints against water penetration.
 - f. Bottom Edges: Close bottom edges of doors where required for attachment of weather stripping with end closures or channels of same material as face sheets. Provide weep-hole openings in bottoms of exterior doors to permit moisture to escape.
 - g. Core: Manufacturer's standard insulated core
2. Frames:
 - a. Materials: Metallic-coated steel sheet, minimum thickness of 0.053 inch (1.3 mm), with minimum A60 (ZF180) coating.
 - b. Construction: Full profile welded.

B. Exposed Finish: Factory Primed.

2.5 FRAME ANCHORS

- A. Jamb Anchors:
 - 1. Stud-Wall Type: Designed to engage stud, welded to back of frames; not less than 0.042 inch (1.0 mm) thick.
 - 2. CMU: Adjustable anchors.
- B. Floor Anchors: Formed from same material as frames, minimum thickness of 0.042 inch (1.0 mm), and as follows:
 - 1. Monolithic Concrete Slabs: Clip-type anchors, with two holes to receive fasteners.

2.6 MATERIALS

- A. Cold-Rolled Steel Sheet: ASTM A 1008/A 1008M, Commercial Steel (CS), Type B; suitable for exposed applications.
- B. Metallic-Coated Steel Sheet: ASTM A 653/A 653M, Commercial Steel (CS), Type B.
- C. Frame Anchors: ASTM A 879/A 879M, Commercial Steel (CS), 04Z (12G) coating designation; mill phosphatized.
 - 1. For anchors built into exterior walls, steel sheet complying with ASTM A 1008/A 1008M or ASTM A 1011/A 1011M, hot-dip galvanized according to ASTM A 153/A 153M, Class B.
- D. Inserts, Bolts, and Fasteners: Hot-dip galvanized according to ASTM A 153/A 153M.
- E. Power-Actuated Fasteners in Concrete: Fastener system of type suitable for application indicated, fabricated from corrosion-resistant materials, with clips or other accessory devices for attaching hollow-metal frames of type indicated.
- F. Bituminous Coating: Cold-applied asphalt mastic, compounded for 15-mil (0.4-mm) dry film thickness per coat. Provide inert-type noncorrosive compound free of asbestos fibers, sulfur components, and other deleterious impurities.

2.7 FABRICATION

- A. Fabricate hollow-metal work to be rigid and free of defects, warp, or buckle. Accurately form metal to required sizes and profiles, with minimum radius for metal thickness. Where practical, fit and assemble units in manufacturer's plant. To ensure proper assembly at Project site, clearly identify work that cannot be permanently factory assembled before shipment.
- B. Hollow-Metal Frames: Where frames are fabricated in sections due to shipping or handling limitations, provide alignment plates or angles at each joint, fabricated of same thickness metal as frames.
 - 1. Provide countersunk, flat- or oval-head exposed screws and bolts for exposed fasteners unless otherwise indicated.

2. Floor Anchors: Weld anchors to bottoms of jambs with at least four spot welds per anchor; however, for slip-on drywall frames, provide anchor clips or countersunk holes at bottoms of jambs.
 3. Jamb Anchors: Provide number and spacing of anchors as follows:
 - a. Stud-Wall Type: Locate anchors not more than 18 inches (457 mm) from top and bottom of frame. Space anchors not more than 32 inches (813 mm) o.c. and as follows:
 - 1) Three anchors per jamb up to 60 inches (1524 mm) high.
 - 2) Four anchors per jamb from 60 to 90 inches (1524 to 2286 mm) high.
 - 3) Five anchors per jamb from 90 to 96 inches (2286 to 2438 mm) high.
 - 4) Five anchors per jamb plus one additional anchor per jamb for each 24 inches (610 mm) or fraction thereof above 96 inches (2438 mm) high.
 - b. Post-installed Expansion Type: Locate anchors not more than 6 inches (152 mm) from top and bottom of frame. Space anchors not more than 26 inches (660 mm) o.c.
 4. Head Anchors: Two anchors per head for frames more than 42 inches (1067 mm) wide and mounted in metal-stud partitions.
 5. Door Silencers: Except on weather-stripped frames, drill stops to receive door silencers as follows. Keep holes clear during construction.
 - a. Single-Door Frames: Drill stop in strike jamb to receive three door silencers.
 - b. Double-Door Frames: Drill stop in head jamb to receive two door silencers.
- C. Fabricate concealed stiffeners and edge channels from either cold- or hot-rolled steel sheet.
- D. Hardware Preparation: Factory prepare hollow-metal work to receive templated mortised hardware; include cutouts, reinforcement, mortising, drilling, and tapping according to SDI A250.6, the Door Hardware Schedule, and templates.
1. Reinforce doors and frames to receive non-templated, mortised, and surface-mounted door hardware.
 2. Comply with applicable requirements in SDI A250.6 and BHMA A156.115 for preparation of hollow-metal work for hardware.

2.8 STEEL FINISHES

- A. Prime Finish: Clean, pretreat, and apply manufacturer's standard primer.
1. Shop Primer: Manufacturer's standard, fast-curing, lead- and chromate-free primer complying with SDI A250.10; recommended by primer manufacturer for substrate; compatible with substrate and field-applied coatings despite prolonged exposure.

PART 3 - EXECUTION

3.1 EXAMINATION

- A. Examine substrates, areas, and conditions, with Installer present, for compliance with requirements for installation tolerances and other conditions affecting performance of the Work.
- B. Examine roughing-in for embedded and built-in anchors to verify actual locations before frame installation.
- C. Prepare written report, endorsed by Installer, listing conditions detrimental to performance of the Work.
- D. Proceed with installation only after unsatisfactory conditions have been corrected.

3.2 PREPARATION

- A. Drill and tap doors and frames to receive non-templated, mortised, and surface-mounted door hardware.

3.3 INSTALLATION

- A. General: Install hollow-metal work plumb, rigid, properly aligned, and securely fastened in place. Comply with Drawings and manufacturer's written instructions.
- B. Hollow-Metal Frames: Install hollow-metal frames of size and profile indicated. Comply with SDI A250.11 or NAAMM-HMMA 840 as required by standards specified.
 - 1. Set frames accurately in position; plumbed, aligned, and braced securely until permanent anchors are set. After wall construction is complete, remove temporary braces, leaving surfaces smooth and undamaged.
 - a. At fire-rated openings, install frames according to NFPA 80.
 - b. Where frames are fabricated in sections because of shipping or handling limitations, field splice at approved locations by welding face joint continuously; grind, fill, dress, and make splice smooth, flush, and invisible on exposed faces.
 - c. Install frames with removable stops located on secure side of opening.
 - d. Install door silencers in frames before grouting.
 - e. Remove temporary braces necessary for installation only after frames have been properly set and secured.
 - f. Check plumb, square, and twist of frames as walls are constructed. Shim as necessary to comply with installation tolerances.
 - g. Field apply bituminous coating to backs of frames that will be filled with grout containing antifreezing agents.
 - 2. Floor Anchors: Provide floor anchors for each jamb and mullion that extends to floor, and secure with post-installed expansion anchors.
 - a. Floor anchors may be set with power-actuated fasteners instead of post-installed expansion anchors if so indicated and approved on Shop Drawings.
 - 3. In-Place Concrete or Masonry Construction: Secure frames in place with post installed expansion anchors. Countersink anchors, and fill and make smooth, flush,

- and invisible on exposed faces.
4. In-Place Metal or Wood-Stud Partitions: Secure slip-on drywall frames in place according to manufacturer's written instructions.
 5. Installation Tolerances: Adjust hollow-metal door frames for squareness, alignment, twist, and plumb to the following tolerances:
 - a. Squareness: Plus or minus 1/16 inch (1.6 mm), measured at door rabbet on a line 90 degrees from jamb perpendicular to frame head.
 - b. Alignment: Plus or minus 1/16 inch (1.6 mm), measured at jambs on a horizontal line parallel to plane of wall.
 - c. Twist: Plus or minus 1/16 inch (1.6 mm), measured at opposite face corners of jambs on parallel lines, and perpendicular to plane of wall.
 - d. Plumbness: Plus or minus 1/16 inch (1.6 mm), measured at jambs at floor.
 6. Smoke-Control Doors: Install doors and gaskets according to NFPA 105.
- C. Glazing: Comply with installation requirements in Section 088000 "Glazing" and with hollow-metal manufacturer's written instructions.
1. Secure stops with countersunk flat- or oval-head machine screws spaced uniformly not more than 9 inches (230 mm) o.c. and not more than 2 inches (51 mm) o.c. from each corner.

3.4 ADJUSTING AND CLEANING

- A. Final Adjustments: Check and readjust operating hardware items immediately before final inspection. Leave work in complete and proper operating condition. Remove and replace defective work, including hollow-metal work that is warped, bowed, or otherwise unacceptable.
- B. Remove grout and other bonding material from hollow-metal work immediately after installation.
- C. Prime-Coat Touchup: Immediately after erection, sand smooth rusted or damaged areas of prime coat and apply touchup of compatible air-drying, rust-inhibitive primer.
- D. Metallic-Coated Surface Touchup: Clean abraded areas and repair with galvanizing repair paint according to manufacturer's written instructions.

END OF SECTION 08 11 13

SECTION 08 71 00 – DOOR HARDWARE

PART 1 - GENERAL

1.1 RELATED DOCUMENTS

- A. Drawings and general provisions of the Contract, including General and Supplementary Conditions and Division 01 Specification Sections, apply to this Section.

1.2 SUMMARY

- A. Section includes: ,
 - 1. Mechanical door hardware for the following:
 - a. Swinging doors.
 - 2. Cylinders for doors specified in other Sections.

1.3 ACTION SUBMITTALS

- A. Product Data: For each type of product indicated. Include construction and installation details, material descriptions, dimensions of individual components and profiles, and finishes.
- B. Samples for Initial Selection: For plastic protective trim units in each finish, color, and texture required for each type of trim unit indicated.
- C. Shop Drawings: Details of electrified and access control hardware, indicating the following:
 - 1. System Block Wiring Diagrams: Detail wiring for power, signal, and control systems and differentiate between manufacturer-installed and field-installed wiring. Include the following for each unique electrified opening:
 - a. Point-to-point system wiring and riser diagrams.
 - b. Elevation diagram of each door.
 - c. Operational description.
- D. Door Hardware Schedule: Prepared by or under the supervision of supplier, detailing fabrication and assembly of door hardware, as well as procedures and diagrams. Coordinate the final Door Hardware Schedule with doors, frames, and related work to ensure proper size, thickness, hand, function, and finish of door hardware.
 - 1. Format: Comply with scheduling sequence and vertical format in DHI's "Sequence and Format for the Hardware Schedule."
 - 2. Organization: Organize the Door Hardware Schedule into door hardware sets indicating complete designations of every item required for each door or opening.

- a. Organize door hardware sets in same order as in the Door Hardware Sets at the end of Part 3. Submittals that do not follow the same format and order as the Door Hardware Sets will be rejected and subject to resubmission.
3. Content: Include the following information:
 - a. Type, style, function, size, label, hand, and finish of each door hardware item.
 - b. Manufacturer of each item.
 - c. Fastenings and other pertinent information.
 - d. Location of door hardware set, cross-referenced to Drawings, both on floor plans and in door and frame schedule.
 - e. Explanation of abbreviations, symbols, and codes contained in schedule.
 - f. Mounting locations for door hardware.
 - g. Door and frame sizes and materials.
 - h. Description of each electrified door hardware function, including location, sequence of operation, and interface with other building control systems.
 - 1) Sequence of Operation: Include description of component functions including, but not limited to, the following situations: normal secured/unsecured state of door; authorized access; authorized egress; unauthorized access; unauthorized egress; fire alarm and loss of power conditions.
 4. Submittal Sequence: Submit the final Door Hardware Schedule at earliest possible date, particularly where approval of the Door Hardware Schedule must precede fabrication of other work that is critical in the Project construction schedule. Include Product Data, Samples, Shop Drawings of other work affected by door hardware, and other information essential to the coordinated review of the Door Hardware Schedule.
- E. Keying Schedule: Prepared under the supervision of the Owner, separate schedule detailing final keying instructions for locksets and cylinders in writing. Include keying system explanation, door numbers, key set symbols, hardware set numbers and special instructions. Owner to approve submitted keying schedule prior to the ordering of permanent cylinders.
- F. Maintenance Data: For each type of door hardware to include in maintenance manuals specified in Division 1. Upon completion of construction and building turnover, furnish two (2) complete maintenance manuals to the owner. Manuals to include the following items:
1. Approved hardware schedule, catalog cuts and keying schedule.
 2. Furnish keying bitting list in paper and electronic format by registered mail directly to facility manager owner.
 3. Hardware installation and adjustment instructions.
 4. Manufacturer's written warranty information.
 5. Wiring diagrams, elevation drawings and operational descriptions for all electronic openings.

1.4 CLOSEOUT SUBMITTALS

- A. Maintenance Data: For each type of door hardware to include in maintenance manuals. Include final hardware and keying schedule.

1.5 QUALITY ASSURANCE

- A. Installer Qualifications: Supplier of products and an employer of workers trained and approved by product manufacturers and an Architectural Hardware Consultant who is available during the course of the Work to consult with Contractor, Architect, and Owner about door hardware and keying.
 - 1. Warehousing Facilities: In Project's vicinity.
 - 2. Scheduling Responsibility: Preparation of door hardware and keying schedules.
 - 3. Engineering Responsibility: Preparation of data for electrified door hardware, including Shop Drawings, based on testing and engineering analysis of manufacturer's standard units in assemblies similar to those indicated for this Project.
- B. Architectural Hardware Consultant Qualifications: A person who is experienced in providing consulting services for door hardware installations that are comparable in material, design, and extent to that indicated for this Project.
- C. Source Limitations: Obtain each type of door hardware from a single manufacturer.
 - 1. Provide electrified door hardware from same manufacturer as mechanical door hardware, unless otherwise indicated. Manufacturers that perform electrical modifications and that are listed by a testing and inspecting agency acceptable to authorities having jurisdiction are acceptable.
- D. Fire-Rated Door Assemblies: Where fire-rated door assemblies are indicated, provide door hardware rated for use in assemblies complying with NFPA 80 that are listed and labeled by a qualified testing agency, for fire-protection ratings indicated, based on testing at positive pressure according to NFPA 252 or UL 10C, unless otherwise indicated.
- E. Smoke- and Draft-Control Door Assemblies: Where smoke- and draft-control door assemblies are required, provide door hardware that meet requirements of assemblies tested according to UL 1784 and installed in compliance with NFPA 105.
 - 1. Air Leakage Rate: Maximum air leakage of **0.3 cfm/sq. ft. (3 cu. m per minute/sq. m)** at the tested pressure differential of **0.3-inch wg (75 Pa)** of water.
- F. Electrified Door Hardware: Listed and labeled as defined in NFPA 70, Article 100, by a testing agency acceptable to authorities having jurisdiction.
- G. Means of Egress Doors: Latches do not require more than **15 lbf (67 N)** to release the latch. Locks do not require use of a key, tool, or special knowledge for operation.
- H. Accessibility Requirements: For door hardware on doors in an accessible route, comply with the

U.S. Architectural & Transportation Barriers Compliance Board's ADA-ABA Accessibility Guidelines ICC/ANSI A117.1.

1. Provide operating devices that do not require tight grasping, pinching, or twisting of the wrist and that operate with a force of not more than 5 lbf (22.2 N).
2. Comply with the following maximum opening-force requirements:
 - a. Interior, Non-Fire-Rated Hinged Doors: 5 lbf (22.2 N) applied perpendicular to door.
 - b. Sliding or Folding Doors: 5 lbf (22.2 N) applied parallel to door at latch.
 - c. Fire Doors: Minimum opening force allowable by authorities having jurisdiction.
3. Bevel raised thresholds with a slope of not more than 1:2. Provide thresholds not more than 1/2 inch (13 mm) high.
4. Adjust door closer sweep periods so that, from an open position of 70 degrees, the door will take at least 3 seconds to move to a point 3 inches (75 mm) from the latch, measured to the leading edge of the door.

1.6 DELIVERY, STORAGE, AND HANDLING

- A. Inventory door hardware on receipt and provide secure lock-up for door hardware delivered to Project site.
- B. Tag each item or package separately with identification coordinated with the final door hardware schedule, and include installation instructions, templates, and necessary fasteners with each item or package.

1.7 COORDINATION

- A. Coordinate layout and installation of floor-recessed door hardware with floor construction. Cast anchoring inserts into concrete.
- B. Installation Templates: Distribute for doors, frames, and other work specified to be factory prepared. Check Shop Drawings of other work to confirm that adequate provisions are made for locating and installing door hardware to comply with indicated requirements.
- C. Security: Coordinate installation of door hardware, keying, and access control with Owner's security consultant.
- D. Electrical System Roughing-In: Coordinate layout and installation of electrified door hardware with connections to power supplies and building safety and security systems.
- E. Existing Openings: Where hardware components are scheduled for application to existing construction or where modifications to existing door hardware are required, field verify existing conditions and coordinate installation of door hardware to suit opening conditions and to provide proper door operation.

1.8 WARRANTY

- A. Special Warranty: Manufacturer's standard form in which manufacturer agrees to repair or

replace components of door hardware that fail in materials or workmanship within specified warranty period.

1. Failures include, but are not limited to, the following:
 - a. Structural failures including excessive deflection, cracking, or breakage.
 - b. Faulty operation of doors and door hardware.
 - c. Deterioration of metals, metal finishes, and other materials beyond normal weathering and use.
2. Warranty Period: Three years from date of Substantial Completion, unless otherwise indicated.
 - a. Electromagnetic Locks: Five years from date of Substantial Completion.
 - b. Locksets: Seven year from date of Substantial Completion.
 - c. Manual Closers: 10 years from date of Substantial Completion.
1. Warranty periods will begin at date of substantial completion.
 - a. Door closers; minimum ten (10) year warranty.
 - b. Lock sets; minimum five (5) year warranty.
 - c. Exit devices; minimum five (5) year warranty.
 - d. Electrical hardware; minimum one (1) year warranty.
 - e. All other hardware items; minimum one (1) year warranty.

1.9 MAINTENANCE SERVICE

- A. Maintenance Tools and Instructions: Furnish a complete set of specialized tools and maintenance instructions for Owner's continued adjustment, maintenance, and removal and replacement of door hardware.
- B. Maintenance Service: Beginning at Substantial Completion, provide six months' full maintenance by skilled employees of door hardware Installer. Include quarterly preventive maintenance, repair or replacement of worn or defective components, lubrication, cleaning, and adjusting as required for proper door and door hardware operation. Provide parts and supplies that are the same as those used in the manufacture and installation of original products.

PART 2 - PRODUCTS

2.1 SCHEDULED DOOR HARDWARE

- A. Provide door hardware for each door as scheduled on Drawings to comply with requirements in this Section.
 1. Door Hardware Sets: Provide quantity, item, size, finish, or color indicated, and named manufacturers' products
 2. Sequence of Operation: Provide electrified door hardware function, sequence of operation, and interface with other building control systems indicated.
- B. Designations: Requirements for design, grade, function, finish, size, and other distinctive

qualities of each type of door hardware are indicated in Part 3 "Door Hardware Schedule" Article. Products are identified by using door hardware designations, as follows:

1. Named Manufacturers' Products: Manufacturer and product designation are listed for each door hardware type required for the purpose of establishing minimum requirements. Manufacturers' names are abbreviated in Part 3 "Door Hardware Schedule" Article.
2. References to BHMA Designations: Provide products complying with these designations and requirements for description, quality, and function.

2.2 HINGES

A. Hinges: BHMA A156.1. Provide template-produced hinges for hinges installed on hollow-metal doors and hollow-metal frames.

1. Manufacturers: Subject to compliance with requirements, available manufacturers offering products that may be incorporated into the Work include, but are not limited to, the following:
2. Basis-of-Design Product: Subject to compliance with requirements, provide product indicated on Drawings or comparable product by one of the following:
 - a. Hager Companies.
 - b. Standard Hinges (Interior):
Provide new 1279 4-1/2 X 4-1/2 X 625 hinges except where existing are called to be reused in door schedule.
 - c. Ball Bearing Hinges (Interior):
Provide new BB1279 4-1/2 X 4-1/2 X 625 hinges except where existing are called to be reused in door schedule.
 - d. Spacing of Hinges:
Provide one additional hinge at 48" wide doors and extra hinges tall doors as required so distance between hinges (vertically) does not to exceed 30".

2.3 MECHANICAL LOCKS AND LATCHES

A. Owner furnish and owner install.

2.4 LOCK CYLINDERS

A. Owner furnish and owner install.

2.5 KEYING

A. Owner furnish and owner install.

2.6 SURFACE CLOSERS (WERE APPLICABLE)

A. Surface Closers: BHMA A156.4; rack-and-pinion hydraulic type with adjustable sweep and

latch speeds controlled by key-operated valves and forged-steel main arm. Comply with manufacturer's written recommendations for size of door closers depending on size of door, exposure to weather, and anticipated frequency of use. Provide factory-sized closers, adjustable to meet field conditions and requirements for opening force.

1. Manufacturers: Subject to compliance with requirements, available manufacturers offering products that may be incorporated into the Work include, but are not limited to, the following:
 - a. Available Manufacturers: Hagar (HAG)
 - b. Series: 5100
 - c. Grade: Heavy duty grade 1
 - d. Type: Tri-packed for mounting regular arm, parallel arm and top jamb mounting.
 - e. Body Material: Cast Iron
 - f. Cover: Full Plastic Cover
 - g. Finish: Painted
 - h. Color: Aluminum

2.7 MECHANICAL STOPS AND HOLDERS

A. Wall- and Floor-Mounted Stops: BHMA A156.16

1. Manufacturers: Subject to compliance with requirements, available manufacturers offering products that may be incorporated into the Work include, but are not limited to, the following:
 - a. Wall Stop: 230W
 - i. Finish: 625 Polished Chrome
 - b. Floor Stop: 242F
 - i. Finish: 625 Polished Chrome
 - c. Provide wall stops (where stops are scheduled) for most door situations; provide floor stops when wall stops will not work. Do not mount floor stops where they will impede traffic. Where floor or wall stops are not appropriate, provide overhead holders.

2.8 STRIKES

A. Electric Strikes:

1. N/A

2.9 DOOR GASKETING

A. Door Gasketing: BHMA A156.22; air leakage not to exceed **0.50 cfm per foot (0.000774 cu. m/s per m)** of crack length for gasketing other than for smoke control, as tested according to ASTM E 283; with resilient or flexible seal strips that are easily replaceable and readily available from stocks maintained by manufacturer.

1. Manufacturers: Subject to compliance with requirements, available manufacturers offering products that may be incorporated into the Work include, but are not

limited to, the following:

- a. Fire Gasketing (PEM). – Single Door
- b. Pemko Manufacturing Co, Inc. (PEM)
 - 1) Model Number: PK33D
 - 2) Finish: Dark Bronze
 - 3) Mounting: Adhesive backing inside corner
 - 4) Gasket Material: Neoprene

2.10 AUXILIARY DOOR HARDWARE

A. Auxiliary Hardware: BHMA A156.16.

- 1. Manufacturers: Subject to compliance with requirements, available manufacturers offering products that may be incorporated into the Work include, but are not limited to, the following:

- a. Hager Companies.

2.11 EXIT DEVICES

A. Exit Devices.

- 1. Requirements and applications:

- a. Heavy duty, Grade 1 types.
- b. Heavy duty trim meeting ANSI – A117.1 accessibility codes.
- c. Thru bolt mounting for all exit devices.
- d. Provide removable core cylinders for locking functions.
- e. Rim types for single doors.
- f. Surface vertical rod types for double doors.
- g. UL listed as panic hardware at non-rated doors.
- h. UL listed as fire exit hardware at fire rated doors.

- 2. Finish:

- a. Satin stainless steel (US32D).

- 3. Acceptable manufacturers and products:

- a. NOTE:
 - 1) Provide UL labeled devices for rated doors as required.
- b. Rim exit device x exit only x no outside trim:
 - 1) Corbin Russwin – ED5200
 - 2) Sargent – 8810
 - 3) Von Duprin –
 - 98EO 4) Yale
 - 7100
- c. Rim exit device x lever trim x storeroom function, provide fire rated types as required for fire rated doors.
 - 1) Corbin Russwin – ED5200 x PR959

- d. Mortise x Vertical rod exit devices x less bottom rods x lever trim x classroom function
 - 1) Corbin Russwin – ED5470 x LBR x PR955
- e. Mortise exit device x lever trim x classroom function
 - 1) Corbin Russwin – ED5600L x PR9M55

2.12 MANUAL FLUSH BOLTS

- A. Manual Flush Bolts: BHMA A156.16; minimum **3/4-inch (19-mm)** throw; designed for mortising into door edge.

2.13 FABRICATION

- A. Manufacturer's Nameplate: Do not provide products that have manufacturer's name or trade name displayed in a visible location except in conjunction with required fire-rated labels and as otherwise approved by Architect.
 - 1. Manufacturer's identification is permitted on rim of lock cylinders only.
- B. Base Metals: Produce door hardware units of base metal indicated, fabricated by forming method indicated, using manufacturer's standard metal alloy, composition, temper, and hardness. Furnish metals of a quality equal to or greater than that of specified door hardware units and BHMA A156.18.
- C. Fasteners: Provide door hardware manufactured to comply with published templates prepared for machine, wood, and sheet metal screws. Provide screws that comply with commercially recognized industry standards for application intended, except aluminum fasteners are not permitted. Provide Phillips flat-head screws with finished heads to match surface of door hardware, unless otherwise indicated.
 - 1. Concealed Fasteners: For door hardware units that are exposed when door is closed, except for units already specified with concealed fasteners. Do not use through bolts for installation where bolt head or nut on opposite face is exposed unless it is the only means of securely attaching the door hardware. Where through bolts are used on hollow door and frame construction, provide sleeves for each through bolt.
 - 2. Fire-Rated Applications:
 - a. Wood or Machine Screws: For the following:
 - 1) Hinges mortised to doors or frames; use threaded-to-the-head wood screws for wood doors and frames.
 - 2) Strike plates to frames.
 - 3) Closers to doors and frames.
 - b. Steel Through Bolts: For the following unless door blocking is provided:
 - 1) Surface hinges to doors.
 - 2) Closers to doors and frames.
 - 3) Surface-mounted exit devices.

3. Spacers or Sex Bolts: For through bolting of hollow-metal doors.
4. Fasteners for Wood Doors: Comply with requirements in DHI WDHS.2, "Recommended Fasteners for Wood Doors."
5. Gasketing Fasteners: Provide noncorrosive fasteners for exterior applications and elsewhere as indicated.

2.14 FINISHES

- A. Provide finishes complying with BHMA A156.18 as indicated in door hardware schedule.
- B. Protect mechanical finishes on exposed surfaces from damage by applying a strippable, temporary protective covering before shipping.
- C. Appearance of Finished Work: Variations in appearance of abutting or adjacent pieces are acceptable if they are within one-half of the range of approved Samples. Noticeable variations in the same piece are not acceptable. Variations in appearance of other components are acceptable if they are within the range of approved Samples and are assembled or installed to minimize contrast.

PART 3 - EXECUTION

3.1 EXAMINATION

- A. Examine doors and frames, with Installer present, for compliance with requirements for installation tolerances, labeled fire-rated door assembly construction, wall and floor construction, and other conditions affecting performance.
- B. Examine roughing-in for electrical power systems to verify actual locations of wiring connections before electrified door hardware installation.
- C. Proceed with installation only after unsatisfactory conditions have been corrected.

3.2 PREPARATION

- A. Steel Doors and Frames: For surface applied door hardware, drill and tap doors and frames according to ANSI/SDI A250.6.
- B. Wood Doors: Comply with DHI WDHS.5 "Recommended Hardware Reinforcement Locations for Mineral Core Wood Flush Doors."

3.3 INSTALLATION

- A. Mounting Heights: Mount door hardware units at heights to comply with the following unless otherwise indicated or required to comply with governing regulations.
 1. Standard Steel Doors and Frames: ANSI/SDI A250.8.
 2. Wood Doors: DHI WDHS.3, "Recommended Locations for Architectural Hardware for Wood Flush Doors."

- B. Install each door hardware item to comply with manufacturer's written instructions. Where cutting and fitting are required to install door hardware onto or into surfaces that are later to be painted or finished in another way, coordinate removal, storage, and reinstallation of surface protective trim units with finishing. Do not install surface-mounted items until finishes have been completed on substrates involved.
 - 1. Set units level, plumb, and true to line and location. Adjust and reinforce attachment substrates as necessary for proper installation and operation.
 - 2. Drill and countersink units that are not factory prepared for anchorage fasteners. Space fasteners and anchors according to industry standards.
- C. Hinges: Install types and in quantities indicated in door hardware schedule but not fewer than the number recommended by manufacturer for application indicated or one hinge for every 30 inches (750 mm) of door height, whichever is more stringent, unless other equivalent means of support for door, such as spring hinges or pivots, are provided.
- D. Lock Cylinders: Install construction cores to secure building and areas during construction period.
 - 1. Contractor shall purchase and furnish best cores to the owner. The Owner will key and install all cores.
- E. Boxed Power Supplies: Locate power supplies as indicated or, if not indicated, above accessible ceilings. Verify location with Architect.
 - 1. Configuration: Provide least number of power supplies required to adequately serve doors with electrified door hardware.
- F. Stops: Provide wall stops for doors unless floor or other type stops are indicated in door hardware schedule. Do not mount floor stops where they will impede traffic.
- G. Perimeter Gasketing: Apply to head and jamb, forming seal between door and frame.

3.4 FIELD QUALITY CONTROL

3.5 ADJUSTING

- A. Initial Adjustment: Adjust and check each operating item of door hardware and each door to ensure proper operation or function of every unit. Replace units that cannot be adjusted to operate as intended. Adjust door control devices to compensate for final operation of heating and ventilating equipment and to comply with referenced accessibility requirements.
 - 1. Spring Hinges: Adjust to achieve positive latching when door is allowed to close freely from an open position of 30 degrees.
 - 2. Door Closers: Adjust sweep period to comply with accessibility requirements and requirements of authorities having jurisdiction.
- B. Occupancy Adjustment: Approximately three months after date of Substantial Completion,

Installer's Architectural Hardware Consultant shall examine and readjust each item of door hardware, including adjusting operating forces, as necessary to ensure function of doors, door hardware, and electrified door hardware.

3.6 CLEANING AND PROTECTION

- A. Clean adjacent surfaces soiled by door hardware installation.
- B. Clean operating items as necessary to restore proper function and finish.
- C. Provide final protection and maintain conditions that ensure that door hardware is without damage or deterioration at time of Substantial Completion.

3.7 DOOR HARDWARE SCHEDULE

- A. Locksets, exit devices, and other hardware items are referenced in the following hardware sets for series, type and function. Refer to the above-specifications for special features, options, cylinders/keying, and other requirements.
- B. Hardware Sets:

General Notes:

Provide cylinders as required for each door
Provide cores for each lock set to owner. Owner will key and install. Provide new mutes at all hollow metal door frames.

END OF SECTION 08 71 00

SECTION 09 22 16 – NON STRUCTURAL METAL FRAMING

PART 1 - GENERAL

1.1 RELATED DOCUMENTS

- A. Drawings and general provisions of the Contract, including General and Supplementary Conditions and Division 01 Specification Sections, apply to this Section.

1.2 SUMMARY

- A. Section Includes:
 - 1. Non-load-bearing steel framing systems for interior gypsum board assemblies.
 - 2. Suspension systems for interior gypsum ceilings, soffits, and grid systems.

1.3 ACTION SUBMITTALS

- A. Product Data: For each type of product.

1.4 INFORMATIONAL SUBMITTALS

- A. Evaluation Reports: For dimpled steel studs and runners, from ICC-ES.

PART 2 - PRODUCTS

2.1 FRAMING SYSTEMS

- A. Framing Members, General: Comply with ASTM C 754 for conditions indicated.
 - 1. Steel Sheet Components: Comply with ASTM C 645 requirements for metal unless otherwise indicated.
 - 2. Protective Coating: ASTM A 653/A 653M, G40 (Z120), hot-dip galvanized unless otherwise indicated.
- B. Studs and Runners: ASTM C 645. Use either steel studs and runners or dimpled steel studs and runners.
 - 1. Steel Studs and Runners:
 - a. Minimum Base-Metal Thickness flat steel:
 - 1) Design thickness .0312 or minimum thickness .0296 inch (0.99 mm). [20ga.] up to 14'-0" in length.

- 2) Design thickness 0.051 or .0428 inch (1.29mm) minimum thickness [18ga.] over 14'-0" in length.
 - b. Depth: As indicated on Drawings.
- 2. Dimpled Steel Studs and Runners:
 - Manufactures published 20 ga equivalent or 18 ga equivalent
 - a. Depth: As indicated on Drawings.
 - b. Products: Subject to compliance with requirements, available products that may be incorporated into the Work include, but are not limited to, the following:
 - 1) Dietrich Metal Framing; SLP-TRK Slotted Deflection Track.

2.2 AUXILIARY MATERIALS

- A. General: Provide auxiliary materials that comply with referenced installation standards.
 - 1. Fasteners for Metal Framing: Of type, material, size, corrosion resistance, holding power, and other properties required to fasten steel members to substrates.
- B. Isolation Strip at Exterior Walls: Provide one of the following:
 - 1. Asphalt-Saturated Organic Felt: ASTM D 226, Type I (No. 15 asphalt felt), non-perforated.
 - 2. Foam Gasket: Adhesive-backed, closed-cell vinyl foam strips that allow fastener penetration without foam displacement, 1/8 inch (3.2 mm) thick, in width to suit steel stud size.

PART 3 - EXECUTION

3.1 EXAMINATION

- A. Examine areas and substrates, with Installer present, and including welded hollow-metal frames, cast-in anchors, and structural framing, for compliance with requirements and other conditions affecting performance of the Work.
- B. Proceed with installation only after unsatisfactory conditions have been corrected.

3.2 INSTALLATION, GENERAL

- A. Installation Standard: ASTM C 754.
 - 1. Gypsum Board Assemblies: Also comply with requirements in ASTM C 840 that apply to framing installation.
- B. Install supplementary framing, and blocking to support fixtures, equipment services, heavy trim, grab bars, toilet accessories, furnishings, or similar construction.
- C. Install bracing at terminations in assemblies.
- D. Do not bridge building control and expansion joints with non-load-bearing steel framing members. Frame both sides of joints independently.

3.3 INSTALLING FRAMED ASSEMBLIES

- A. Install framing system components according to spacings indicated, but not greater than spacings required by referenced installation standards for assembly types.
 - 1. Single-Layer Application: 16 inches (406 mm)
 - 2. Multilayer Application: 16 inches (406 mm)
- B. Where studs are installed directly against exterior masonry walls or dissimilar metals at exterior walls, install isolation strip between studs and exterior wall.
- C. Install studs so flanges within framing system point in same direction.
- D. Install tracks (runners) at floors and overhead supports. Extend framing full height to structural supports or substrates above suspended ceilings except where partitions are indicated to terminate at suspended ceilings. Continue framing around ducts penetrating partitions above ceiling.
 - 1. Door Openings:
 - a. Install two studs at each jamb unless otherwise indicated provide:
 - 1) .0493 (18ga) studs at door jambs where doors are wider than 3'-0" but less than 3'-6"
 - 2) .0508 (16ga) studs at door jambs when doors are wider than 3'-6"
 - 2. Other Framed Openings: Frame openings other than door openings the same as required for door openings unless otherwise indicated. Install framing below sills of openings to match framing required above door heads.
 - 3. Fire-Resistance-Rated Partitions: Install framing to comply with fire-resistance-rated assembly indicated and support closures and to make partitions continuous from floor to underside of solid structure.

END OF SECTION 09 22 16

SECTION 09 29 00 – GYPSUM BOARD

PART 1 - GENERAL

1.1 RELATED DOCUMENTS

- A. Drawings and general provisions of the Contract, including General and Supplementary Conditions and Division 01 Specification Sections, apply to this Section.

1.2 SUMMARY

A. Section Includes:

1. Interior gypsum board
2. Sound Attenuation Blankets

B. Related Requirements:

1. Section 092216 "Non-Structural Metal Framing" for non-structural framing and suspension systems that support gypsum board panels.

1.3 ACTION SUBMITTALS

- A. Product Data: For each type of product.

1.4 DELIVERY, STORAGE AND HANDLING

- A. Store materials inside under cover and keep them dry and protected against weather, condensation, direct sunlight, construction traffic, and other potential causes of damage. Stack panels flat and supported on risers on a flat platform to prevent sagging.

1.5 FIELD CONDITIONS

- A. Environmental Limitations: Comply with ASTM C 840 requirements or gypsum board manufacturer's written recommendations, whichever are more stringent.
- B. Do not install paper-faced gypsum panels until installation areas are enclosed and conditioned.
- C. Do not install panels that are wet, those that are moisture damaged, and those that are mold damaged.
 1. Indications that panels are wet or moisture damaged include, but are not limited to, discoloration, sagging, or irregular shape.
 2. Indications that panels are mold damaged include, but are not limited to, fuzzy or splotchy surface contamination and discoloration.

PART 2 - PRODUCTS

2.1 PERFORMANCE REQUIREMENTS

- A. Fire-Resistance-Rated Assemblies: For fire-resistance-rated assemblies, provide materials and construction identical to those tested in assembly indicated according to ASTM E 119 by an independent testing agency.

2.2 GYPSUM BOARD, GENERAL

- A. Size: Provide maximum lengths and widths available that will minimize joints in each area and that correspond with support system indicated.

2.3 INTERIOR GYPSUM BOARD

- A. Manufacturers: Subject to compliance with requirements, available manufacturers offering products that may be incorporated into the Work include, but are not limited to, the following:

1. National Gypsum Company.
2. USG Corporation.

- B. **ALL WALLS:** Moisture- and Mold-Resistant Gypsum Board: ASTM C 1396/C 1396M. With moisture- and mold-resistant core and paper surfaces.

1. Core: 5/8 inch (15.9 mm), Type X.
2. Long Edges: Tapered.
3. Mold Resistance: ASTM D 3273, score of 10 as rated according to ASTM D 3274.
4. **Location:** All walls.

- C. Moisture- and Mold-Resistant Gypsum Board: ASTM C 1396/C 1396M. With moisture- and mold-resistant core and paper surfaces.

1. Core: 1/2 inch (12.7 mm), Type X.
2. Long Edges: Tapered.
3. Mold Resistance: ASTM D 3273, score of 10 as rated according to ASTM D 3274.
4. **Location:** Ceilings

2.4 TRIM ACCESSORIES

- A. Interior Trim: ASTM C 1047.

1. Material: **Galvanized or aluminum-coated steel sheet or rolled zinc.**
2. Shapes:
 - a. Cornerbead.
 - b. LC-Bead: J-shaped; exposed long flange receives joint compound.
 - c. L-Bead: L-shaped; exposed long flange receives joint compound.

2.5 JOINT TREATMENT MATERIALS

- A. General: Comply with ASTM C 475/C 475M.
- B. Joint Tape:
 - 1. Interior Gypsum Board: Paper.
- C. Joint Compound for Interior Gypsum Board: National Gypsum ProForm XP Joint compound with Dust-Tech.
 - 1. Prefilling: At open joints, rounded or beveled panel edges, and damaged surface areas, use setting-type taping compound.
 - 2. Embedding and First Coat: For embedding tape and first coat on joints, fasteners, and trim flanges, use setting-type taping compound.
 - a. Use setting-type compound for installing paper-faced metal trim accessories.
 - 3. Fill Coat: For second coat, use setting-type, sandable topping or drying-type, all-purpose compound.
 - 4. Finish Coat: For third coat, use setting-type, sandable topping or drying-type, all-purpose compound.
 - 5. Skim Coat: For final coat of Level 4 finish, use setting-type, sandable topping compound or drying-type, all-purpose compound.

2.6 AUXILIARY MATERIALS

- A. General: Provide auxiliary materials that comply with referenced installation standards and manufacturer's written recommendations.
- B. Steel Drill Screws: ASTM C 1002, unless otherwise indicated.
 - 1. Use screws complying with ASTM C 954 for fastening panels to steel members from 0.033 to 0.112 inch (0.84 to 2.84 mm) thick.
 - 2. For fastening cementitious backer units, use screws of type and size recommended by panel manufacturer.
- C. Sound Attenuation Blankets: ASTM C 665, Type I (blankets without membrane facing) produced by combining thermosetting resins with mineral fibers manufactured from glass, slag wool, or rock wool.
 - 1. Thickness: 3-1/2"
 - 2. Sound Transmission Coefficient: Provide 45 STC minimum rating at walls identified as sound walls on drawings.
 - 3. Fire-Resistance-Rated Assemblies: Comply with mineral-fiber requirements of assembly.

- D. Acoustical Joint Sealant: Manufacturer's standard nonsag, paintable, nonstaining latex sealant complying with ASTM C 834. Product effectively reduces airborne sound transmission through perimeter joints and openings in building construction as demonstrated by testing representative assemblies according to ASTM E 90.
 - 1. Products: Subject to compliance with requirements, available products that may be incorporated into the Work include, but are not limited to, the following:
 - a. Pecora Corporation; AC-20 FTR.
 - b. Metacaulk 1200 Acoustical Fire rated sealant

PART 3 - EXECUTION

3.1 EXAMINATION

- A. Examine areas and substrates including welded hollow-metal frames and framing, with Installer present, for compliance with requirements and other conditions affecting performance.
- B. Examine panels before installation. Reject panels that are wet, moisture damaged, and mold damaged.
- C. Proceed with installation only after unsatisfactory conditions have been corrected.

3.2 APPLYING AND FINISHING PANELS, GENERAL

- A. Comply with ASTM C 840.
- B. Install ceiling panels across framing to minimize the number of abutting end joints and to avoid abutting end joints in central area of each ceiling. Stagger abutting end joints of adjacent panels not less than one framing member.
- C. Install panels with face side out. Butt panels together for a light contact at edges and ends with not more than 1/16 inch (1.5 mm) of open space between panels. Do not force into place.
- D. Locate edge and end joints over supports, except in ceiling applications where intermediate supports or gypsum board back-blocking is provided behind end joints. Do not place tapered edges against cut edges or ends. Stagger vertical joints on opposite sides of partitions. Do not make joints other than control joints at corners of framed openings.
- E. Cover both faces of support framing with gypsum panels in concealed spaces (above ceilings, etc.), except in chases braced internally.
 - 1. Fit gypsum panels around ducts, pipes, and conduits.
 - 2. Where partitions intersect structural members projecting below underside of floor/roof slabs and decks, cut gypsum panels to fit profile formed by structural members; allow 1/4- to 3/8-inch- (6.4- to 9.5-mm-) wide joints to install sealant.

- F. Isolate perimeter of gypsum board applied to non-load-bearing partitions at structural abutments, except floors. Provide 1/4- to 1/2-inch- (6.4- to 12.7-mm-) wide spaces at these locations and trim edges with edge trim where edges of panels are exposed. Seal joints between edges and abutting structural surfaces with acoustical sealant.
- G. Attachment to Steel Framing: Attach panels so leading edge or end of each panel is attached to open (unsupported) edges of stud flanges first.
- H. Install sound attenuation blankets before installing gypsum panels unless blankets are readily installed after panels have been installed on one side.

3.3 APPLYING INTERIOR GYPSUM BOARD

- A. Install interior gypsum board in the following locations:
 - 1. Type X: Vertical surfaces unless otherwise indicated.
 - 2. Ceiling Type: Ceiling surfaces and furrings.
 - 3. Moisture- and Mold-Resistant Type: In all bathroom, and shower areas.
- B. Single-Layer Application:
 - 1. On ceilings, apply gypsum panels before wall/partition board application to greatest extent possible and at right angles to framing unless otherwise indicated.
 - 2. On partitions/walls, apply gypsum panels **vertically (parallel to framing)** unless otherwise indicated or required by fire-resistance-rated assembly, and minimize end joints.
 - a. Stagger abutting end joints not less than one framing member in alternate courses of panels.
 - b. At stairwells and other high walls, install panels horizontally unless otherwise indicated or required by fire-resistance-rated assembly.
 - 3. On Z-furring members, apply gypsum panels vertically (parallel to framing) with no end joints. Locate edge joints over furring members.
 - 4. Fastening Methods: Apply gypsum panels to supports with steel drill screws.
- C. Multilayer Application:
 - 1. On ceilings, apply gypsum board indicated for base layers before applying face layers on walls/partitions; apply face layers in same sequence. Apply base layers at right angles to framing members and offset face-layer joints one framing member, 16 inches (400 mm) minimum, from parallel base-layer joints, unless otherwise indicated or required by fire-resistance-rated assembly.
 - 2. On partitions/walls, apply gypsum board indicated for base layers and face layers vertically (parallel to framing) with joints of base layers located over stud or furring member and face-layer joints offset at least one stud or furring member with base-layer joints, unless otherwise indicated or required by fire-resistance-rated assembly. Stagger joints on opposite sides of partitions.
 - 3. On Z-furring members, apply base layer vertically (parallel to framing) and face layer either vertically (parallel to framing) or horizontally (perpendicular to framing) with

vertical joints offset at least one furring member. Locate edge joints of base layer over furring members.

4. Fastening Methods: Fasten base layers with screws; fasten face layers with adhesive and supplementary fasteners.

- D. Laminating to Substrate: Where gypsum panels are indicated as directly adhered to a substrate (other than studs, joists, furring members, or base layer of gypsum board), comply with gypsum board manufacturer's written recommendations and temporarily brace or fasten gypsum panels until fastening adhesive has set.

3.4 INSTALLING TRIM ACCESSORIES

- A. General: For trim with back flanges intended for fasteners, attach to framing with same fasteners used for panels. Otherwise, attach trim according to manufacturer's written instructions.
- B. Interior Trim: Install in the following locations:
 1. Cornerbead: Use at outside corners unless otherwise indicated.
 2. L-Bead: Use where indicated.
 3. U-Bead: Use where indicated.

3.5 FINISHING GYPSUM BOARD

- A. General: Treat gypsum board joints, interior angles, edge trim, control joints, penetrations, fastener heads, surface defects, and elsewhere as required to prepare gypsum board surfaces for decoration. Promptly remove residual joint compound from adjacent surfaces.
- B. Prefill open joints, rounded or beveled edges, and damaged surface areas.
- C. Apply joint tape over gypsum board joints, except for trim products specifically indicated as not intended to receive tape.
- D. Gypsum Board Finish Levels: Finish panels to levels indicated below and according to ASTM C 840:
 1. Level 1: Ceiling plenum areas, concealed areas, and where indicated.
 2. Level 2: Panels that are substrate for acoustical sound board.
 3. Level 4: At panel surfaces that will be exposed to view unless otherwise indicated.
 - a. Primer and its application to surfaces are specified in Section 099123 "Interior Painting."

- E. **SANDING: ALL MAJOR SANDING IS TO BE PERFORMED WITH A HEPA VAC DRYWALL SANDER.**

3.6 PROTECTION

- A. Protect adjacent surfaces from drywall compound and promptly remove from floors and other non-drywall surfaces. Repair surfaces stained, marred, or otherwise damaged during drywall application.
- B. Protect installed products from damage from weather, condensation, direct sunlight,

construction, and other causes during remainder of the construction period.

C. Remove and replace panels that are wet, moisture damaged, and mold damaged.

1. Indications that panels are wet and/or moisture damaged include, but are not limited to, discoloration, sagging, or irregular shape.
2. Indications that panels are mold damaged include, but are not limited to, fuzzy or splotchy surface contamination and discoloration.

END OF SECTION 09 29 00

SECTION 09 51 13 – ACOUSTICAL PANEL CEILINGS

PART 1 - GENERAL

1.1 RELATED DOCUMENTS

- A. Drawings and general provisions of the Contract, including General and Supplementary Conditions and Division 01 Specification Sections, apply to this Section.

1.2 SUMMARY

- A. Section includes acoustical panels and exposed suspension systems for ceilings.

1.3 ACTION SUBMITTALS

- A. Product Data: For each type of product.
- B. Samples: For each exposed product and for each color and texture specified, 6 inches (150 mm) in size.
- C. Samples for Verification: For each component indicated and for each exposed finish required, prepared on Samples of size indicated below.
 - 1. Acoustical Panel: Set of 6-inch- (150-mm-) square Samples of each type, color, pattern, and texture.
 - 2. Exposed Suspension-System Members, Moldings, and Trim: Set of 6-inch- (150-mm-) long Samples of each type, finish, and color.

1.4 CLOSEOUT SUBMITTALS

- A. Maintenance Data: For finishes to include in maintenance manuals.

1.5 DELIVERY, STORAGE, AND HANDLING

- A. Deliver acoustical panels, suspension-system components, and accessories to Project site in original, unopened packages and store them in a fully enclosed, conditioned space where they will be protected against damage from moisture, humidity, temperature extremes, direct sunlight, surface contamination, and other causes.
- B. Before installing acoustical panels, permit them to reach room temperature and a stabilized moisture content.
- C. Handle acoustical panels carefully to avoid chipping edges or damaging units in any way.

1.6 FIELD CONDITIONS

- A. Environmental Limitations: Do not install acoustical panel ceilings until spaces are enclosed and weatherproof, wet work in spaces is complete and dry, work above ceilings is complete, and ambient temperature and humidity conditions are maintained at the levels indicated for Project when occupied for its intended use.

1. Pressurized Plenums: Operate ventilation system for not less than 48 hours before beginning acoustical panel ceiling installation.

PART 2 - PRODUCTS

2.1 PERFORMANCE REQUIREMENTS

- A. Surface-Burning Characteristics: Comply with ASTM E 84; testing by a qualified testing agency. Identify products with appropriate markings of applicable testing agency.

2.2 ACOUSTICAL PANELS, GENERAL

- A. Source Limitations:

1. Acoustical Ceiling Panel: Obtain each type from single source from single manufacturer.
2. Suspension System: Obtain each type from single source from single manufacturer.

- B. Acoustical Panel Standard: Provide manufacturer's standard panels of configuration indicated that comply with ASTM E 1264 classifications as designated by types, patterns, acoustical ratings, and light reflectances unless otherwise indicated.

1. Mounting Method for Measuring NRC: Type E-400; plenum mounting in which face of test specimen is 15-3/4 inches (400 mm) away from test surface according to ASTM E 795.

- C. Acoustical Panel Colors and Patterns: Match appearance characteristics indicated for each product type.

1. Where appearance characteristics of acoustical panels are indicated by referencing pattern designations in ASTM E 1264 and not manufacturers' proprietary product designations, provide products selected by Architect from each manufacturer's full range that comply with requirements indicated for type, pattern, color, light reflectance, acoustical performance, edge detail, and size.

2.3 ACOUSTICAL PANELS (C-1) Standard

- A. Basis-of-Design Product: Subject to compliance with requirements, available products that may be incorporated into the Work include, but are not limited to, the following:

1. USG
 - a. Item Number: See schedule on drawings.

- B. Classification: Provide fire-resistance-rated panels complying with ASTM E 1264 for type, form, and pattern as follows:

1. Type and Form: Type III, mineral base with painted finish.
2. Form 2, water felted.
3. Pattern: CE - C (perforated, small holes), and E (lightly textured).

- C. Color: White.
- D. LR: Not less than 0.84.
- E. NRC: Not less than 0.55.
- F. CAC: Not less than 33.
- G. Fire Rating: Class A
- H. Edge/Joint Detail: Square.
- I. Thickness: 5/8" inch (15.8 mm).
- J. Modular Size: 24 by 24 inches (610 by 610 mm).
- K. Weight: 1.05 lbs/SF (64 SF/ctn).
- L. Hold Down Clips: Not Required.
- M. Broad Spectrum Antimicrobial Fungicide and Bactericide Treatment: Provide acoustical panels treated with manufacturer's standard antimicrobial formulation that inhibits fungus, mold, mildew, and gram-positive and gram-negative bacteria and showing no mold, mildew, or bacterial growth when tested according to ASTM D 3273 and evaluated according to ASTM D 3274 or ASTM G 21.
 - 1. Anti-Microbial: BioBlock+
- N. Sag Resistance: ClimaPlus
- O. Grid: USG DONN DX / DXL (Type A)

2.4 ACOUSTICAL PANELS (C-2) Shower Rooms & Restrooms

- A. Basis-of-Design Product: Subject to compliance with requirements, available products that may be incorporated into the Work include, but are not limited to, the following:
 - 1. USG
 - a. Item Number: See schedule on drawings
- B. Classification: Provide fire-resistance-rated panels complying with ASTM E84 Class A for type, form, and pattern as follows:
 - 1. Type and Form: Type XX, high-density, ceramic- and mineral-base panels with scrubbable finish, resistant to heat, moisture, and corrosive fumes
 - 2. Pattern: CEG perforated, small holes and lightly textured
- C. Color: White.
- D. LR: Not less than 0.82.

- E. NRC: Not less than 0.50.
- F. CAC: Not less than 40.
- G. Fire Rating:
 - 1. Class A
 - 2. Flame Spread: 0
 - 3. Smoke Development: 0
- H. Edge/Joint Detail: Square.
- I. Thickness: 5/8" inch (15.8 mm).
- J. Modular Size: 24 by 24 inches (610 by 610 mm).
- K. Weight: 1.6-1.7 lbs/SF.
- L. Hold Down Clips: Not Required.
- M. Totally inorganic product; resistant to the growth of mold and mildew, Includes sag-resistant performance.
- N. Sag Resistance: ClimaPlus 30-year lifetime system warranty against visible sag, mold and mildew
- O. Grid: USG DONN AX/AXCE (**Type B**)

2.5 METAL SUSPENSION SYSTEMS, GENERAL

- A. Metal Suspension-System Standard: Provide manufacturer's standard direct-hung metal suspension systems of types, structural classifications, and finishes indicated that comply with applicable requirements in ASTM C 635/C 635M.
 - 1. High-Humidity Finish: Comply with ASTM C 635/C 635M requirements for "Coating Classification for Severe Environment Performance" where high-humidity finishes are indicated.
- B. Attachment Devices: Size for five times the design load indicated in ASTM C 635/C 635M, Table 1, "Direct Hung," unless otherwise indicated. Comply with seismic design requirements.
- C. Wire Hangers, Braces, and Ties: Provide wires complying with the following requirements:
 - 1. Zinc-Coated, Carbon-Steel Wire: ASTM A 641/A 641M, Class 1 zinc coating, soft temper.
 - 2. Size: Select wire diameter so its stress at three times hanger design load (ASTM C 635/C 635M, Table 1, "Direct Hung") will be less than yield stress of wire, but provide not less than 0.106-inch- (2.69-mm-) diameter wire.
- D. Flat Hangers: Mild steel, zinc coated or protected with rust-inhibitive paint.

- E. Angle Hangers: Angles with legs not less than 7/8 inch (22 mm) wide; formed with 0.04-inch- (1-mm-) thick, galvanized-steel sheet complying with ASTM A 653/A 653M, G90 (Z275) coating designation; with bolted connections and 5/16-inch- (8-mm-) diameter bolts.

2.6 METAL SUSPENSION SYSTEM (TYPE A).

- A. Basis-of-Design Product: Subject to compliance with requirements, products that may be incorporated into the Work include, but are not limited to, the following:
 - 1. USG Interiors, Inc.; Subsidiary of USG Corporation Donn DX/DXL.
- B. Wide-Face, Galvanized Steel Capped, Double-Web, Hot-Dip Galvanized, G30, Steel Suspension System: Main and cross runners roll formed from cold-rolled steel sheet; hot-dip galvanized according to ASTM A 653/A 653M, G30 coating designation; prefinished, 15/16- inch flanges.
 - 1. Structural Classification: Intermediate-duty system.
 - 2. Face Design: Flat, flush.
 - 3. Face Finish: Painted white.

2.7 METAL EDGE MOLDINGS AND TRIM

- A. Manufacturers: Subject to compliance with requirements, available manufacturers offering products that may be incorporated into the Work include, but are not limited to, the following:
 - 1. USG Interiors, Inc.; Subsidiary of USG Corporation.
- B. Roll-Formed, Sheet-Metal Edge Moldings and Trim: Type and profile indicated or, if not indicated, manufacturer's standard moldings for edges and penetrations that comply with seismic design requirements; formed from sheet metal of same material, finish, and color as that used for exposed flanges of suspension-system runners.
 - 1. Provide manufacturer's standard edge moldings that fit acoustical panel edge details and suspension systems indicated and that match width and configuration of exposed runners unless otherwise indicated.

2.8 METAL SUSPENSION SYSTEM (TYPE B).

- A. Basis-of-Design Product: Subject to compliance with requirements, products that may be incorporated into the Work include, but are not limited to, the following:
 - 1. USG Interiors, Inc.; Subsidiary of USG Corporation Donn AX/AXCE.
- B. Wide-Face, Aluminum-Capped, Double-Web tee aluminum, stainless steel quick release clip, Steel Suspension System, 15/16-inch flanges. 2. Stainless-Steel Wire: ASTM A 580/A 580M, Type 304, nonmagnetic Suspension System

1. Structural Classification: Intermediate-duty system.
2. Face Design: Flat, flush.
3. Face Finish: Painted white.

2.9 METAL EDGE MOLDINGS AND TRIM

- A. Manufacturers: Subject to compliance with requirements, available manufacturers offering products that may be incorporated into the Work include, but are not limited to, the following:
 1. USG Interiors, Inc.; Subsidiary of USG Corporation.
- B. Extruded-Aluminum Edge Moldings and Trim: Where indicated, provide manufacturer's extruded-aluminum edge moldings and trim of profile indicated or referenced by manufacturer's designations, including splice plates, corner pieces, and attachment and other clips, complying with seismic design requirements.
 1. Baked-Enamel or Powder-Coat Finish: Minimum dry film thickness of **1.5 mils (0.04 mm)**. Comply with ASTM C 635/C 635M and coating manufacturer's written instructions for cleaning, conversion coating, and applying and baking finish.
 2. Provide manufacturer's standard edge moldings that fit acoustical panel edge details and suspension systems indicated and that match width and configuration of exposed runners unless otherwise indicated.

2.10 ACOUSTICAL SEALANT

- A. Products: Subject to compliance with requirements, available products that may be incorporated into the Work include, but are not limited to, the following:
 1. Acoustical Sealant for Exposed and Concealed Joints:
 - a. Pecora Corporation; AC-20 FTR Acoustical and Insulation Sealant.
 - b. USG Corporation; SHEETROCK Acoustical Sealant.
- B. Acoustical Sealant: Manufacturer's standard sealant complying with ASTM C 834 and effective in reducing airborne sound transmission through perimeter joints and openings in building construction as demonstrated by testing representative assemblies according to ASTM E 90.
 1. Exposed and Concealed Joints: Non-sag, paintable, non-staining latex sealant.
 2. Concealed Joints: Nondrying, non-hardening, non-skinning, non-staining, gunnable, synthetic-rubber sealant.

PART 3 - EXECUTION

3.1 EXAMINATION

- A. Examine substrates, areas, and conditions, including structural framing to which acoustical panel ceilings attach or abut, with Installer present, for compliance with

requirements specified in this and other Sections that affect ceiling installation and anchorage and with requirements for installation tolerances and other conditions affecting performance of acoustical panel ceilings.

- B. Examine acoustical panels before installation. Reject acoustical panels that are wet, moisture damaged, or mold damaged.
- C. Proceed with installation only after unsatisfactory conditions have been corrected.

3.2 PREPARATION

- A. Measure each ceiling area and establish layout of acoustical panels to balance border widths at opposite edges of each ceiling. Avoid using less-than-half-width panels at borders, and comply with layout shown on reflected ceiling plans.

3.3 INSTALLATION

- A. General: Install acoustical panel ceilings to comply with ASTM C 636/C 636M, according to manufacturer's written instructions and CISCA's "Ceiling Systems Handbook."
- B. Suspend ceiling hangers from building's structural members and as follows:
 - 1. Install hangers plumb and free from contact with insulation or other objects within ceiling plenum that are not part of supporting structure or of ceiling suspension system.
 - 2. Splay hangers only where required, to miss obstructions; offset resulting horizontal forces by bracing, countersplaying, or other equally effective means.
 - 3. Where width of ducts and other construction within ceiling plenum produces hanger spacings that interfere with location of hangers at spacings required to support standard suspension-system members, install supplemental suspension members and hangers in form of trapezes or equivalent devices.
 - 4. Secure wire hangers to ceiling-suspension members and to supports above with a minimum of three tight turns. Connect hangers directly either to structures or to inserts, eye screws, or other devices that are secure and appropriate for substrate and that will not deteriorate or otherwise fail due to age, corrosion, or elevated temperatures.
 - 5. Secure flat, angle, channel, and rod hangers to structure, including intermediate framing members, by attaching to inserts, eye screws, or other devices that are secure and appropriate for both the structure to which hangers are attached and the type of hanger involved. Install hangers in a manner that will not cause them to deteriorate or fail due to age, corrosion, or elevated temperatures.
 - 6. Do not support ceilings directly from permanent metal forms or floor deck. Fasten hangers to cast-in-place hanger inserts, post-installed mechanical or adhesive anchors, or power-actuated fasteners that extend through forms into concrete.
 - 7. When steel framing does not permit installation of hanger wires at spacing required, install carrying channels or other supplemental support for attachment of hanger wires.
 - 8. Do not attach hangers to steel deck tabs.
 - 9. Do not attach hangers to steel roof deck. Attach hangers to structural members.
 - 10. Space hangers not more than 48 inches (1200 mm) o.c. along each member supported directly from hangers unless otherwise indicated; provide hangers not

- more than 8 inches (200 mm) from ends of each member.
11. Size supplemental suspension members and hangers to support ceiling loads within performance limits established by referenced standards and publications.
- C. Secure bracing wires to ceiling suspension members and to supports with a minimum of four tight turns. Suspend bracing from building's structural members as required for hangers, without attaching to permanent metal forms, steel deck, or steel deck tabs. Fasten bracing wires into concrete with cast-in-place or post-installed anchors.
 - D. Install edge moldings and trim of type indicated at perimeter of acoustical ceiling area and where necessary to conceal edges of acoustical panels.
 1. Screw attach moldings to substrate at intervals not more than 16 inches (400 mm) o.c. and not more than 3 inches (75 mm) from ends, leveling with ceiling suspension system to a tolerance of 1/8 inch in 12 feet (3.2 mm in 3.6 m). Miter corners accurately and connect securely.
 2. Do not use exposed fasteners, including pop rivets, on moldings and trim.
 - E. Install suspension-system runners so they are square and securely interlocked with one another. Remove and replace dented, bent, or kinked members.
 - F. Install acoustical panels with undamaged edges and fit accurately into suspension-system runners and edge moldings. Scribe and cut panels at borders and penetrations to provide a neat, precise fit.
 1. Arrange directionally patterned acoustical panels as follows:
 - a. Product is non directional
 2. For square-edged panels, install panels with edges fully hidden from view by flanges of suspension-system runners and moldings.
 - G. **Install Sealant at all wall Edge Moldings and Trim**

3.4 CLEANING

- A. Clean exposed surfaces of acoustical panel ceilings, including trim, edge moldings, and suspension-system members. Comply with manufacturer's written instructions for cleaning and touchup of minor finish damage. Remove and replace ceiling components that cannot be successfully cleaned and repaired to permanently eliminate evidence of damage.

END OF SECTION 09 51 13

SECTION 09 65 13 – RESILIENT BASE AND ACCESSORIES

PART 1 - GENERAL

1.1 RELATED DOCUMENTS

- A. Drawings and general provisions of the Contract, including General and Supplementary Conditions and Division 01 Specification Sections, apply to this Section.

1.2 SUMMARY

- A. Section Includes:

- 1. Resilient base.

- B. Related Sections:

- 1. Section 096519 "Resilient Tile Flooring" for resilient floor tile.

1.3 ACTION SUBMITTALS

- A. Product Data: For each type of product indicated.

- B. Samples for Initial Selection (If not selected and shown on drawings): For each type of product indicated.

1.4 QUALITY ASSURANCE

- A. Fire-Test-Response Characteristics: As determined by testing identical products according to ASTM E 648 or NFPA 253 by a qualified testing agency.

- 1. Critical Radiant Flux Classification: Class I, not less than 0.45 W/sq. cm.

- B. Mockups: Provide resilient products with mockups.

1.5 DELIVERY, STORAGE, AND HANDLING

- A. Store resilient products and installation materials in dry spaces protected from the weather, with ambient temperatures maintained within range recommended by manufacturer, but not less than 50 deg F (10 deg C) or more than 90 deg F (32 deg C).

1.6 PROJECT CONDITIONS

- A. Maintain ambient temperatures within range recommended by manufacturer, but not less than 70 deg F (21 deg C) or more than 95 deg F (35 deg C), in spaces to receive resilient products during the following time periods:
 - 1. 48 hours before installation.
 - 2. During installation.
 - 3. 48 hours after installation.
- B. Until Substantial Completion, maintain ambient temperatures within range recommended by manufacturer, but not less than 55 deg F (13 deg C) or more than 95 deg F (35 deg C).
- C. Install resilient products after other finishing operations, including painting, have been completed.

PART 2 - PRODUCTS

2.1 RESILIENT BASE

- A. Standard Resilient Base:
 - 1. Manufacturers: Subject to compliance with requirements, available manufacturers offering products that may be incorporated into the Work include, but are not limited to, the following:
 - a. Johnsonite
- B. Resilient Base Standard: ASTM F 1861.
 - 1. Material Requirement: Type TP (rubber, thermoplastic).
 - 2. Manufacturing Method: Group I (solid, homogeneous).
 - 3. Style: Cove (base with toe).
 - 4. Minimum Thickness: 1/8" (3.175 mm).
 - 5. Height: 4 inches (102 mm).
 - 6. Lengths: Coils in manufacturer's standard length.
 - 7. Outside Corners: Job formed or preformed.
 - 8. Inside Corners: Job formed.
 - 9. Finish: Matte.
 - 10. Color: To be selected from Manufacturer's full range of available colors.

2.2 INSTALLATION MATERIALS

- A. Trowelable Leveling and Patching Compounds: Latex-modified, portland cement based or blended hydraulic-cement-based formulation provided or approved by manufacturer for applications indicated.
- B. Adhesives: Water-resistant type recommended by manufacturer to suit resilient products and substrate conditions indicated.

PART 3 - EXECUTION

3.1 EXAMINATION

- A. Examine substrates, with Installer present, for compliance with requirements for maximum moisture content and other conditions affecting performance of the Work.
- B. Verify that finishes of substrates comply with tolerances and other requirements specified in other Sections and that substrates are free of cracks, ridges, depressions, scale, and foreign deposits that might interfere with adhesion of resilient products.
- C. Proceed with installation only after unsatisfactory conditions have been corrected.

3.2 PREPARATION

- A. Prepare substrates according to manufacturer's written instructions to ensure adhesion of resilient products.
- B. Fill cracks, holes, and depressions in substrates with trowelable leveling and patching compound and remove bumps and ridges to produce a uniform and smooth substrate.
- C. Do not install resilient products until they are same temperature as the space where they are to be installed.
 - 1. Move resilient products and installation materials into spaces where they will be installed at least 48 hours in advance of installation.
- D. Sweep and vacuum clean substrates to be covered by resilient products immediately before installation.

3.3 RESILIENT BASE INSTALLATION

- A. Comply with manufacturer's written instructions for installing resilient base.
- B. Apply resilient base to walls, columns, pilasters, casework and cabinets in toe spaces, and other permanent fixtures in rooms and areas where base is required.
- C. Install resilient base in lengths as long as practicable without gaps at seams and with tops of adjacent pieces aligned.
- D. Tightly adhere resilient base to substrate throughout length of each piece, with base in continuous contact with horizontal and vertical substrates.
- E. Do not stretch resilient base during installation. On masonry surfaces or other similar irregular substrates, fill voids along top edge of resilient base with manufacturer's recommended adhesive filler material.
- F. Job-Formed Corners:
 - 1. Outside Corners: Use straight pieces of maximum lengths possible. Form without producing discoloration (whitening) at bends.
 - 2. Inside Corners: Use straight pieces of maximum lengths possible.

3.4 RESILIENT ACCESSORY INSTALLATION

- A. Comply with manufacturer's written instructions for installing resilient accessories.
- B. Resilient Molding Accessories: Butt to adjacent materials and tightly adhere to substrates throughout length of each piece. Install reducer strips at edges of carpet and resilient floor covering that would otherwise be exposed.

3.5 CLEANING AND PROTECTION

- A. Comply with manufacturer's written instructions for cleaning and protection of resilient products.
- B. Perform the following operations immediately after completing resilient product installation:
 - 1. Remove adhesive and other blemishes from exposed surfaces.
 - 2. Sweep and vacuum surfaces thoroughly.
 - 3. Damp-mop surfaces to remove marks and soil.
- C. Protect resilient products from mars, marks, indentations, and other damage from construction operations and placement of equipment and fixtures during remainder of construction period.
- D. Cover resilient products until Substantial Completion.

END OF SECTION 09 65 13

SECTION 09 91 23 – INTERIOR PAINTING

PART 1 - GENERAL

1.1 RELATED DOCUMENTS

- A. Drawings and general provisions of the Contract, including General and Supplementary Conditions and Division 01 Specification Sections, apply to this Section.

1.2 SUMMARY

- A. Section includes surface preparation and the application of paint systems on the following interior substrates:
 - 1. Steel.
 - 2. Gypsum board.
 - 3. CMU
 - 4. Plaster
 - 5. Structural or CMU Glazed Tile
- B. Related Requirements:
 - 1. Section 099113 "Exterior Painting" for surface preparation and the application of paint systems on exterior substrates.

1.3 DEFINITIONS

- A. Gloss Level 1: Not more than 5 units at 60 degrees and 10 units at 85 degrees, according to ASTM D 523. (Traditional Matte finish)
- B. Gloss Level 2: Not more than 10 units at 60 degrees and 10 to 35 units at 85 degrees, according to ASTM D 523. (High side sheen flat – velvet-like finish)
- C. Gloss Level 3: 10 to 25 units at 60 degrees and 10 to 35 units at 85 degrees, according to ASTM D 523. (Traditional “egg-shell-like finish”)
- D. Gloss Level 4: 20 to 35 units at 60 degrees and not less than 35 units at 85 degrees, according to ASTM D 523. (a “satin-like” finish)
- E. Gloss Level 5: 35 to 70 units at 60 degrees, according to ASTM D 523. (traditional semi-gloss)
- F. Gloss Level 6: 70 to 85 units at 60 degrees, according to ASTM D 523. (Traditional gloss)
- G. Gloss Level 7: More than 85 units at 60 degrees, according to ASTM D 523. (High gloss)

1.4 ACTION SUBMITTALS

- A. Product Data: For each type of product. Include preparation requirements and application

instructions.

- B. Samples for Initial Selection: For each type of topcoat product.
- C. Product List: For each product indicated, include the following:
 - 1. Cross-reference to paint system and locations of application areas. Use same designations indicated on Drawings and in schedules.

1.5 MAINTENANCE MATERIAL SUBMITTALS

- A. Furnish extra materials, from the same product run, that match products installed and that are packaged with protective covering for storage and identified with labels describing contents.
 - 1. Paint: Provide 1 gal. (3.8 L) of each material and color applied.

1.6 DELIVERY, STORAGE, AND HANDLING

- A. Store materials not in use in tightly covered containers in well-ventilated areas with ambient temperatures continuously maintained at not less than 45 deg F (7 deg C).
 - 1. Maintain containers in clean condition, free of foreign materials and residue.
 - 2. Remove rags and waste from storage areas daily.

1.7 FIELD CONDITIONS

- A. Apply paints only when temperature of surfaces to be painted and ambient air temperatures are between 50 and 95 deg F (10 and 35 deg C).
- B. Do not apply paints when relative humidity exceeds 85 percent; at temperatures less than 5 deg F (3 deg C) above the dew point; or to damp or wet surfaces.

PART 2 - PRODUCTS

2.1 MANUFACTURERS

- A. All paint and primers provided by owner.

2.2 PAINT, GENERAL

A. Material Compatibility:

1. Provide materials for use within each paint system that are compatible with one another and substrates indicated, under conditions of service and application as demonstrated by manufacturer, based on testing and field experience.
2. For each coat in a paint system, provide products recommended in writing by manufacturers of topcoat for use in paint system and on substrate indicated.

B. Colors: As indicated on drawings or as selected by Architect from manufacturer's full range.

2.3 PRIMERS/SEALERS

A. Provided by owner.

2.4 METAL PRIMERS

A. Provided by owner.

2.5 WATER-BASED PAINTS

A. Provided by owner.

2.6 SOLVENT-BASED PAINTS

A. Provided by owner.

2.7 INTUMESCENT FIRE RETARDANT

A. Provided by owner.

PART 3 - EXECUTION

3.1 EXAMINATION

A. Examine substrates and conditions, with Applicator present, for compliance with requirements for maximum moisture content and other conditions affecting performance of the Work.

B. Maximum Moisture Content of Substrates: When measured with an electronic moisture meter as follows:

1. Concrete: 12 percent.
2. Masonry (Clay and CMU): 12 percent.
3. Wood: 15 percent.
4. Gypsum Board: 12 percent.
5. Plaster: 12 percent.

- C. Gypsum Board Substrates: Verify that finishing compound is sanded smooth.
- D. Plaster Substrates: Verify that plaster is fully cured.
- E. Verify suitability of substrates, including surface conditions and compatibility with existing finishes and primers.
- F. Proceed with coating application only after unsatisfactory conditions have been corrected.
 - 1. Application of coating indicates acceptance of surfaces and conditions.

3.2 PREPARATION

- A. Comply with manufacturer's written instructions and recommendations in "MPI Manual" applicable to substrates indicated.
- B. Remove hardware, covers, plates, and similar items already in place that are removable and are not to be painted. If removal is impractical or impossible because of size or weight of item, provide surface-applied protection before surface preparation and painting.
 - 1. After completing painting operations, use workers skilled in the trades involved to reinstall items that were removed. Remove surface-applied protection if any.
- C. Clean substrates of substances that could impair bond of paints, including dust, dirt, oil, grease, and incompatible paints and encapsulants.
 - 1. Remove incompatible primers and reprime substrate with compatible primers or apply tie coat as required to produce paint systems indicated.
- D. Steel Substrates: Remove rust, loose mill scale, and shop primer, if any. Clean using methods recommended in writing by paint manufacturer. but not less than the following:
 - 1. SSPC-SP 2, "Hand Tool Cleaning."
 - 2. SSPC-SP 3, "Power Tool Cleaning."
 - 3. SSPC-SP 7/NACE No. 4, "Brush-off Blast Cleaning."
 - 4. SSPC-SP 11, "Power Tool Cleaning to Bare Metal."
- E. Shop-Primed Steel Substrates: Clean field welds, bolted connections, and abraded areas of shop paint, and paint exposed areas with the same material as used for shop priming to comply with SSPC-PA 1 for touching up shop-primed surfaces.
- F. Galvanized-Metal Substrates: Remove grease and oil residue from galvanized sheet metal fabricated from coil stock by mechanical methods to produce clean, lightly etched surfaces that promote adhesion of subsequently applied paints.
- G. Wood Substrates:
 - 1. Scrape and clean knots and apply coat of knot sealer before applying primer.
 - 2. Sand surfaces that will be exposed to view and dust off.
 - 3. Prime edges, ends, faces, undersides, and backsides of wood.

4. After priming, fill holes and imperfections in the finish surfaces with putty or plastic wood filler. Sand smooth when dried.

3.3 APPLICATION

- A. Apply paints according to manufacturer's written instructions and to recommendations in "MPI Manual."
 1. Use applicators and techniques suited for paint and substrate indicated.
 2. Paint surfaces behind movable equipment and furniture same as similar exposed surfaces. Before final installation, paint surfaces behind permanently fixed equipment or furniture with prime coat only.
 3. Paint front and backsides of access panels, removable or hinged covers, and similar hinged items to match exposed surfaces.
 4. Do not paint over labels of independent testing agencies or equipment name, identification, performance rating, or nomenclature plates.
 5. Primers specified in painting schedules may be omitted on items that are factory primed or factory finished if acceptable to topcoat manufacturers.
- B. Tint each undercoat a lighter shade to facilitate identification of each coat if multiple coats of same material are to be applied. Tint undercoats to match color of topcoat, but provide sufficient difference in shade of undercoats to distinguish each separate coat.
- C. If undercoats or other conditions show through topcoat, apply additional coats until cured film has a uniform paint finish, color, and appearance.
- D. Apply paints to produce surface films without cloudiness, spotting, holidays, laps, brush marks, roller tracking, runs, sags, ropiness, or other surface imperfections. Cut in sharp lines and color breaks.
- E. Painting Fire Suppression, Plumbing, HVAC, Electrical, Communication, and Electronic Safety and Security Work:
 1. Paint the following work where exposed in equipment rooms:
 - a. Equipment, including panelboards and switch gear.
 - b. Uninsulated metal piping.
 - c. Uninsulated plastic piping.
 - d. Pipe hangers and supports.
 - e. Metal conduit.
 - f. Plastic conduit.
 - g. Tanks that do not have factory-applied final finishes.
 - h. Duct, equipment, and pipe insulation having cotton or canvas insulation covering or other paintable jacket material.
 2. Paint the following work where exposed in occupied spaces:
 - a. Equipment, including panelboards.
 - b. Uninsulated metal piping.
 - c. Uninsulated plastic piping.
 - d. Pipe hangers and supports.

- e. Metal conduit.
- f. Plastic conduit.
- g. Duct, equipment, and pipe insulation having cotton or canvas insulation covering or other paintable jacket material.
- h. Other items as directed by Architect.

- 3. Paint portions of internal surfaces of metal ducts, without liner, behind air inlets and outlets that are visible from occupied spaces.

3.4 CLEANING AND PROTECTION

- A. At end of each workday, remove rubbish, empty cans, rags, and other discarded materials from Project site.
- B. After completing paint application, clean spattered surfaces. Remove spattered paints by washing, scraping, or other methods. Do not scratch or damage adjacent finished surfaces.
- C. Protect work of other trades against damage from paint application. Correct damage to work of other trades by cleaning, repairing, replacing, and refinishing, as approved by Architect, and leave in an undamaged condition.
- D. At completion of construction activities of other trades, touch up and restore damaged or defaced painted surfaces.

3.5 INTERIOR PAINTING SCHEDULE

- A. N/A

3.6 COLOR SCHEDULE

- A. Colors will be selected by Architect from full range of available colors of paints.

3.7 TOUCH UP PAINTING

- A. **Provide an allowance for touching up 500 square feet for damaged walls, after substantial completion, as a result of owner move-in.**

END OF SECTION 09 91 23

SECTION 10 44 16 – FIRE EXTINGUISHERS

PART 1 - GENERAL

1.1 RELATED DOCUMENTS

- A. Drawings and general provisions of the Contract, including General and Supplementary Conditions and Division 01 Specification Sections, apply to this Section.

1.2 SUMMARY

- A. Section includes portable, fire extinguishers **and mounting brackets for fire extinguishers.**

1.3 ACTION SUBMITTALS

- A. Product Data: For each type of product indicated. Include rating and classification, material descriptions, dimensions of individual components and profiles, and finishes for fire extinguisher and mounting brackets.
- B. Product Schedule: For fire extinguishers. Coordinate final fire extinguisher schedule with fire protection cabinet schedule to ensure proper fit and function. Use same designations indicated on Drawings.

1.4 INFORMATIONAL SUBMITTALS

- A. Warranty: Sample of special warranty.

1.5 CLOSEOUT SUBMITTALS

- A. Operation and Maintenance Data: For fire extinguishers to include in maintenance manuals.

1.6 QUALITY ASSURANCE

- A. NFPA Compliance: Fabricate and label fire extinguishers to comply with NFPA 10, "Portable Fire Extinguishers."
- B. Fire Extinguishers: Listed and labeled for type, rating, and classification by an independent testing agency acceptable to authorities having jurisdiction.
 - 1. Provide fire extinguishers approved, listed, and labeled by FMG.

1.7 COORDINATION

- A. Coordinate type and capacity of fire extinguishers with fire protection cabinets to ensure fit and function.

1.8 WARRANTY

- A. Special Warranty: Manufacturer's standard form in which manufacturer agrees to repair or replace fire extinguishers that fail in materials or workmanship within specified warranty period.
 - 1. Failures include, but are not limited to, the following:
 - a. Failure of hydrostatic test according to NFPA 10.
 - b. Faulty operation of valves or release levers.
 - 2. Warranty Period: Six years from date of Substantial Completion.

PART 2 - PRODUCTS

2.1 PORTABLE, HAND-CARRIED FIRE EXTINGUISHERS

- A. Fire Extinguishers: Type, size, and capacity for each fire protection cabinet and mounting bracket indicated.
 - 1. Manufacturers: Subject to compliance with requirements, available manufacturers offering products that may be incorporated into the Work include, but are not limited to, the following:
 - 2. Basis-of-Design Product: Subject to compliance with requirements, provide product name or designation or comparable product by one of the following:
 - a. J. L. Industries, Inc.; a division of Activar Construction Products Group.
 - b. Larsen's Manufacturing Company.
 - 3. Valves: Manufacturer's standard.
 - 4. Handles and Levers: Manufacturer's standard.
 - 5. Instruction Labels: Include pictorial marking system complying with NFPA 10, Appendix B and bar coding for documenting fire extinguisher location, inspections, maintenance, and recharging.
- B. Multipurpose Dry-Chemical Type in Steel Container: UL-rated 2-A:10-B:C, 5-lb (2.3-kg) nominal capacity, with monoammonium phosphate-based dry chemical in enameled-steel container.
 - 1. Inside all fire extinguisher cabinets and as noted in locations except where noted otherwise below:

2.2 MOUNTING BRACKETS (FEB)

- A. Mounting Brackets: Manufacturer's standard **galvanized** steel, designed to secure fire extinguisher to wall or structure, of sizes required for types and capacities of fire extinguishers indicated, with plated or **black** baked-enamel finish.
 - 1. Manufacturers: Subject to compliance with requirements, available manufacturers offering products that may be incorporated into the Work include, but are not limited to, the following:
 - a. J. L. Industries, Inc.: a division of Activar Construction Products Group.
 - b. Larsen's Manufacturing Company.
- B. Identification: Lettering complying with authorities having jurisdiction for letter style, size, spacing, and location. Locate as indicated by Architect.
 - 1. Identify bracket-mounted fire extinguishers with the words "FIRE EXTINGUISHER" in red letter decals applied to mounting surface.
 - a. Orientation: Vertical.

PART 3 - EXECUTION

3.1 EXAMINATION

- A. Examine fire extinguishers for proper charging and tagging.
 - 1. Remove and replace damaged, defective, or undercharged fire extinguishers.
- B. Proceed with installation only after unsatisfactory conditions have been corrected.

3.2 INSTALLATION

- A. General: Install fire extinguishers and mounting brackets in locations indicated and in compliance with requirements of authorities having jurisdiction.
 - 1. Mounting Brackets: 54 inches (1372 mm) above finished floor to top of fire extinguisher.
- B. Mounting Brackets: Fasten mounting brackets to surfaces, square and plumb, at locations indicated.

END OF SECTION 10 44 16

CERTIFICATION OF RESPONSIBILITY FOR
DOCUMENT PREPARATION

NIRC Building 30 3rd Floor IT Renovation
RCE Project No.: 230015

MECHANICAL SPECIFICATIONS

THE FOLLOWING SPECIFICATION SECTIONS INCLUDED IN THIS PROJECT MANUAL WERE PREPARED BY OR UNDER THE RESPONSIBLE SUPERVISION OF THE COMPANY LISTED BELOW:

23 05 00	GENERAL PROVISIONS FOR HVAC
23 05 03	BASIC MATERIALS AND METHODS FOR HVAC
23 05 93	TESTING, ADJUSTING, AND BALANCING FOR HVAC
23 07 00	MECHANICAL INSULATION
23 09 00	TEMPERATURE CONTROLS FOR HVAC
23 30 00	AIR DISTRIBUTION FOR HVAC
23 70 00	AIR CONDITIONING FOR HVAC

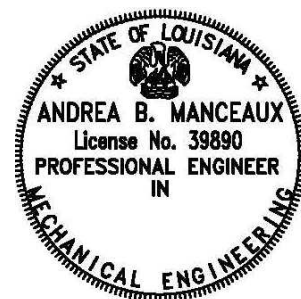

5/25/2023

Andrea B. Manceaux, P.E.
Ritter Consulting Engineers Ltd

SECTION 23 05 00 - GENERAL PROVISIONS FOR HVAC

I. GENERAL

A. DIVISION OF SPECIFICATIONS

1. For Bidder's convenience only, this Division of the Specifications is divided into the following parts:

23 05 00	GENERAL PROVISIONS FOR HVAC
23 05 03	BASIC MATERIALS AND METHODS FOR HVAC
23 05 93	TESTING, ADJUSTING, AND BALANCING FOR HVAC
23 07 00	MECHANICAL INSULATION
23 09 00	TEMPERATURE CONTROLS FOR HVAC
23 30 00	AIR DISTRIBUTION FOR HVAC
23 70 00	AIR CONDITIONING FOR HVAC

B. GENERAL CONDITIONS

1. The General Conditions of the Architectural Specifications along with supplementary conditions, special conditions, information to bidders, and any other pertinent information and documents shall apply the same as if repeated herein. The contractor shall review Architectural General Conditions. Where the requirements of Architectural General Conditions and these specs conflict for the contractor, the most stringent shall be applied.
2. Mechanical subcontractor shall be the sole source responsible party to furnish and install the mechanical system. Mechanical contractor shall be properly licensed to perform this work.
3. Wherever the word contractor is mentioned in Division 23 of these specifications, it is intended to mean the Mechanical Contractor as appropriate. These are sub contractors to the General Contractor who has the contract with the owner. It is the General Contractor who bears the responsibility to fulfill this part of the project (Division 23 – Mechanical) under the contract with the owner. The General Contractor shall be responsible for all costs associated with any and all bidding errors and omissions of the sub-contractor.

C. SCOPE OF WORK

1. Furnish labor, materials and equipment necessary to provide and install the complete mechanical portion of this contract, including air conditioning, heating, and ventilating systems as called for herein and on accompanying drawings. Parts of the mechanical division may be bid separately or in combination at the contractor's option; however, it shall be the responsibility of the General Contractor to assure himself that all items

covered in the Mechanical Division have been included if he chooses to accept separate bids.

2. Contractor shall refer to the Architectural, Structural, Plumbing and Electrical drawings and install all equipment, piping, etc., to meet building and space requirements. **No equipment shall be bid on or submitted for approval if it will not fit in space provided or coordinated with other trades involved on the project.**
3. It is the intention of these Specifications that all mechanical systems shall be furnished complete with all necessary valves, controls, insulation, piping, devices, equipment, etc., necessary to provide a satisfactory installation in working order and in accordance with all Federal, State and Local codes and ordinances.
4. Contractor shall visit the site and acquaint himself thoroughly with all existing facilities and conditions which would affect his portion of the work. Failure to do so shall not relieve the contractor from the responsibility of installing his work to meet conditions.
5. Lack of coordination shall not be acceptable and shall not be a reason for poorly installed work or additional cost to this trade or others on the project. All associated extra cost shall be borne by the contractor. The General Contractor shall be responsible for all costs, time and liquidated damages associated with lack of coordination or poor coordination.

D. LOCAL CONDITIONS

1. Location and elevation of all services is based on information obtained from the Owner. However, this shall serve as a general guide only and the contractor shall visit the site and verify the location and elevation of this service to his own satisfaction in order to determine the amount of work required for the execution of the contract.
2. Contractor shall contact the various utility companies, determine the extent of their requirements and cooperate with the utility company in reaching a finished product. Contractor shall pay charges by Utility Company for extensions, connections meter fees, street patching, etc.
3. In case major changes are required, this fact, together with the reasons therefore, shall be submitted to the Architect, in writing, not less than seven days before the date of bidding. Failure to comply with this requirement will make the contractor liable for any changes, additions and expenses necessary for the successful completion of the project.

E. CUTTING AND PATCHING

1. Initial cutting and patching shall be the responsibility of the General Contractor with the Mechanical Contractor responsible for laying out and

marking any and all holes required for the reception of his work. No structural beams or joists shall be cut or thimble without first receiving the approval of the Architect/Engineer. After initial surfacing has been done, any further cutting, patching and painting shall be done at this contractor's expense.

2. Cutting and patching shall be done in such a manner that the surrounding work will be restored to its original condition.
3. The HVAC piping shall be run in such a manner as to avoid conflicts with other trades. It may be necessary to penetrate beams, grade beams, footings, and foundations. Install thimbles as required and as approved by the Structural Engineer and Architect.

F. CODES AND STANDARDS

1. The entire mechanical work shall comply with the rules and regulations of the City, Parish and State in which this project is being constructed including the State Fire Marshal and State Board of Health. All modifications required by these authorities shall be made without additional charge to the Owners. The Mechanical Contractor shall report these changes to the Architect and secure his approval before work is started.
2. In addition to the codes mentioned, all mechanical work and equipment shall conform to the applicable portions of the following Specifications, codes and regulations:
 - a. American Society of Heating, Refrigeration and Air Conditioning Engineers
 - b. National Electric Code
 - c. National Fire Protection Association
 - d. American Society of Mechanical Engineers
 - e. Underwriters's Laboratories
 - f. American Gas Association
 - g. Energy Code for Commercial and High Rise Residential Buildings
 - h. International Energy Conservation Code
 - i. International Building Code
 - j. International Mechanical Code
 - k. SMACNA Guidelines
3. Materials, equipment and accessories installed under this contract shall conform to all rules, codes, etc., as recommended by National Associations governing the manufacturer, rating and testing of such materials, equipment and accessories. Materials shall be new and of the best quality and first class in every respect. Whenever directed by the Architect, contractor shall submit a sample for approval before proceeding.

4. Where laws or local regulations provide that certain accessories such as gauges, thermometers, relief valves and parts be installed on equipment, it shall be understood that such equipment be furnished complete with the necessary accessories whether or not called for in these Specifications.
5. Material and equipment furnished or installed as part of these construction documents shall be installed and operated in strict accordance with the respective manufacturer's guidelines for installation and operating instructions. The manufacturer's guidelines shall become part of the construction documents.

G. MINOR DEVIATIONS

1. Plans and detail sketches are submitted to limit, explain and define conditions, specified requirements, pipe sizes and manner of erecting work. Structural or other conditions may require certain modifications from the manner of installation shown and such deviations are permissible and shall be made as required, but, specified sizes and requirements necessary for satisfactory operation shall remain unchanged. It may be necessary to shift ducts or pipes or to change the shape of ducts and these changes shall be made as required. All such changes shall be referred to the Architect/Engineer for approval before proceeding. Extra charges shall not be allowed for these changes.
2. No structural beams or joists (concrete or steel) shall be cut or thimble without first receiving the approval of the Architect/Structural Engineer. After initial surfacing has been done, any further cutting, patching and painting shall be done at the Mechanical Contractor's own expense.
3. Contractor shall realize that the drawings could delve into every step, sequence or operation necessary for the completion of the project without drawing on the contractor's experience or ingenuity. However, only typical details are shown on the plans. In cases where the contractor is not certain about the method of installation of his work, he shall ask for details. Lack of details shall not be an excuse for improper installation. Submit installation shop drawings with manufacturer's details for review prior to installation.
4. In general, the drawings are diagrammatic and the contractor shall install his work in a manner so that interferences between the various trades are avoided. In cases where interferences do occur, the Architect is to state which equipment, piping, etc., is to be relocated regardless of which item was first installed.
5. Materials and equipment furnished or installed as part of these construction documents shall be installed and operated in strict accordance with the respective manufacturer's guidelines for installation and operating instructions. The manufacturer's guidelines shall become part of the construction documents.

H. WORKMANSHIP

1. Workmanship shall be of highest grade, highest quality and all construction shall be done according to the best practice of the trade. Work shall be completed to satisfaction of the Architect/Engineer.

I. COORDINATION

1. Coordinate work of the different trades to avoid interferences between mechanical and all other work. All piping, ductwork, etc., shall be installed in lines as required to accomplish this end whether or not shown on the plans.
2. There will be a certain amount of work which must be coordinated with the Owner. This contractor shall coordinate required work with the Owner through the General Contractor using procedures acceptable to the Architect and Owner. The contractor shall maintain documentation of coordinated work.
3. This contractor shall coordinate and confirm that all equipment requiring electric service will be adequately and properly serviced by Electrical Contractor. Any conflicts shall be brought to the attention of the Architect/Engineer prior to ordering the equipment. **VERIFY ALL VOLTAGES WITH THE ELECTRICAL PLANS AND ELECTRICAL CONTRACTOR.**
4. This contractor shall coordinate the space clearances required for the HVAC ductwork with the structure, ceilings, lights, etc. In some cases, due to space limitations, it may be necessary to re-size ductwork to meet the conditions of the project. **Any resizing required shall be part of this project and done without any additional cost to the Owner. DO NOT MAKE DUCTWORK WITHOUT COORDINATION. Avoid conflicts with other trades.**
5. This contractor shall coordinate the installation of HVAC piping with all parts of the structural foundation system and structural building systems. Provide sleeves through grade beams or concrete beams at all conflicts. All points of penetration of foundation shall be reviewed by the Architect/Engineer prior to rough-in. All sleeves shall be installed per instructions and details of the structural engineer.
6. All piping shall be run as high as possible with sleeves through concrete beams to avoid conflicts. This means the piping shall run in or through the structure unless approved otherwise by the Architect/Engineer.

J. REVIEW OF MATERIALS

1. Whenever manufacturers or trade names are mentioned in these plans or Specifications, the words "or approved equivalent" shall be assumed to follow whether or not so stated. Manufacturers or trade names are used to establish a standard of quality only and should not be construed to infer a preference. Equivalent products which meet the Architect's approval will be accepted; however, these requests for acceptance of products must be received by the Architect a minimum of ten days prior to bid date. Submission shall include manufacturer's name, model number, rating table and construction features. Upon receipt and checking of this submittal, the Architect will issue an addendum listing items which are approved as equivalent to those specified. The contractor shall base his bid solely on those items specified or included in the "Prior Approval Addendum" as no other item will be acceptable. Prior approval of a particular piece of equipment does not mean automatic final acceptance and will not relieve the contractor of the responsibility of assuring himself that this equipment is in complete accord with plans and Specifications and will fit into the space provided. Submit shop drawings on all items of equipment for approval as hereinafter specified.
2. Should a substitution or variation occur, the better quality or greater quantity of material or work shall be furnished. This also does not preclude other manufacturers if they meet the following criteria:
 - a. Product proposed for substitution shall be equal or superior to that specified in construction, efficiency, utility and function.
 - b. Physical size of substitute brand shall not be greater than space provided for it.
 - c. Profile of substitution shall be same concerning size, shape, indentations, recesses, etc.
 - d. Complete illustrations, specifications and description of substitution shall be submitted for approval.
 - e. Availability and proximity of manufacturer's service representative shall be factors considered in substitution approval.
 - f. Substitution and/or variations shall be reviewed and allowed when there is no change in cost to the project and shall be made at the discretion of the Engineer.

K. SHOP DRAWINGS

1. The General Contractor shall submit mechanical submittal in a timely manner as required to accommodate the construction schedule. The General Contractor and his sub-contractors shall bear all responsibility for any extra costs or delays to late submittals of shop drawings.
2. Drawings shall be presented in a clear and thorough manner.
3. Details shall be identified by reference to sheet detail, schedule or room numbers shown on contract and drawings.

4. Drawings shall contain the following information:
 - a. Date.
 - b. Number of the drawing or revision.
 - c. Name of project or facility.
 - d. Name of contractor and subcontractor.
 - e. Clear identification of contents and location of work.

5. Preparation:
 - a. Clearly mark each copy to identify pertinent products or models.
 - b. Show performance characteristics and capacities.
 - c. Show dimensions and clearances required.
 - d. Show wiring or piping diagrams and controls.
 - e. Show weights and mounting data.
 - f. Provide letter documentation confirming that all coordination with other trades effected have been done. This is especially necessary with the electrical requirements and rough-in requirements.

6. Manufacturer's standard schematic drawings and diagrams:
 - a. Modify drawings and diagrams to delete information which is not applicable to the work.
 - b. Supplement standard information to provide information specifically applicable to the work.

7. Office samples shall be of sufficient size and quantity to clearly illustrate:
 - a. Functional characteristics of the product, with integral related parts and attachment devices.
 - b. Full range of color, texture and pattern.

8. Equipment shop drawing shall be prepared by the contractor/supplier. These shop drawing shall include the manufacturer's performance data and installation manuals. In addition, the shop drawings shall show the installation specific to this project.

9. Assemble certificates, executed by each of the respective manufacturers, suppliers, and subcontractors.

10. All submittals shall be submitted prepaid and in ample time for review before installation.

11. Six (6) copies of each submittal shall be submitted to the Architect.

12. These shop drawings shall be supplied as part of this contractor's contract. Any drawings not approved shall be resubmitted until approved. **Submit all shop drawings at the same time. No separate items will be accepted.**

13. All materials installed in the work shall match the reviewed submittals. After a submission has been reviewed, no substitutions will be permitted without written approval by the Architect.
14. The Architect's/Engineer's review of shop drawings shall not relieve the contractor from the responsibility of incorrectly figured dimensions or any other errors that may be contained in these drawings. The omission from the shop drawings or specifications, even though approved by the Architect, shall not relieve the contractor from furnishing and erecting same.
15. Any delays caused by contractor not submitting shop drawings within a timely manner shall be the problem of the responsible subcontractor and the General Contractor.

L. MATERIALS

1. Work materials shall be new and the best of their respective kinds, and shall bear the label of NFPA, ASME Code, AGA, and UL where such standard has been established for the particular item of equipment used.

M. MATERIAL STORAGE

1. General: Provide space for storage of material and equipment at ground level. Roof surfaces shall not be used for storage of materials or equipment. Any storage within the building shall be approved by the Architect/Engineer prior to use of the space.
2. Exterior: Pipe, fitting, or other materials stored outside of building shall be set on wood or steel racks or platforms inside storage container units. All necessary provisions shall be made to keep water and debris away from such stored material. Ends of pipes and valves shall be kept sealed until used.
3. Warehousing: Equipment subject to rusting shall be kept warehoused until just prior to setting. If necessary the warehouse shall have climate controlled conditions.

N. GROUND AND CHASES

1. Contractor shall see that all required chases, sleeves, grounds, holes and accessories necessary for the installation of his work are properly built in as the work progresses; otherwise he shall bear the cost of providing them.

O. MACHINERY GUARDS

1. Contractor shall provide v-belt guards for each v-belt drive or other hazardous drive. Guard shall enclose the drive entirely and shall have a hole for taking tachometer reading.

P. SPECIAL TOOLS

1. Special tools required for proper operation or maintenance of any mechanical equipment provided under this contract shall be delivered to the Owner at the completion of the project.

Q. FILL AND CHARGES FOR EQUIPMENT

1. Fill and charge with materials or chemicals all devices or equipment as required to comply with the manufacturer's guarantee or as required for proper operation of the equipment.
2. This contractor shall flush systems as required per local and state jurisdictions and equipment/material manufacturer's guidelines (chlorination, chemical treatment, etc.).

R. EQUIPMENT IDENTIFICATION

1. Stenciling: All items of major mechanical equipment (pumps, AHUs, starters, valves, etc.) shall be neatly and clearly stenciled in letters not less than 1 inch high, with the same designation as appears on drawing. Location and color of such stenciling shall be appropriate for ready identification and/or as directed by the Architect. One set of compatible metal interlocking stencil letters and numbers shall be turned over to the Owner at the completion of the job. At contractor's option engraved plastic adhesive tags may be used. Tags used outdoors shall be listed for such use.
2. Pipe Coding: All piping, etc., both insulated and bare, shall be color coded with a general purpose pipe marker for interior locations and a 6 inch enamel painted band for exterior locations, and stenciled as to service and characteristics on the 10 foot centers and/or as directed. Directional arrows not less than 1/2 inch wide and not less than 6 inches long shall be permanently stenciled on each line at each stencil location. Stenciling shall be located such that it is clearly visible from floor or adjacent service platform. Coding shall be as per schedule approved by Owner through submittal to Architect. At contractor's option, pre-manufactured vinyl pipe labels and directional arrows may be used but shall be banded on either end to secure to pipe.
3. Valve tags shall be installed on all valves controlling building zones, areas, or equipment. Valve tags shall be 2 inch diameter brass stenciled with valve number. A framed list of valves with associated numbers, sizes and locations shall be mounted in the building as directed by Architect.

S. TEMPORARY USE OF EQUIPMENT

1. The permanent equipment installation shall not be used for temporary purposes by the contractor for temporary conditioning of the building during construction. **Contractor shall provide temporary dehumidification and drying equipment as required to maintain clean, dry air during construction.**
2. Acceptable Use Without Specific Authorization: Temporary use shall not be construed to mean "bumping" of electric motors on equipment to verify rotation direction nor short time operation of systems for test purposes, operation of refrigeration and heating system for short periods to adjust controls and temperature regulation, or the operation of fans for air balance.

T. CLEANING AND ADJUSTING

1. Upon completion of his work, the contractor shall clean and adjust all equipment, controls, valves, etc. Clean all piping, ductwork, etc., and leave entire installation in good working order.

U. SERVICE

1. Inspect, clean and service air filters immediately prior to final acceptance of project.
2. Provide lubrication for operation of equipment until final acceptance of the equipment by the Owner. Protect bearings during installation and thoroughly grease steel shafts to prevent corrosion. Provide extended lubrication lines for parts requiring lubrication which are concealed or inaccessible.
3. Provide complete and working charge of proper refrigerant, free of contaminants, into each refrigerant system. After each system has been in operation long enough to ensure completely balanced condition, check the charge and modify it for proper operation as required.
4. Place mechanical systems in complete working order and clean and polish fixtures, equipment and materials thoroughly returning to "as new" condition prior to request for final review.
5. Remove excess material and debris. Clean out lines and fittings and adjust valves. Broom clean areas. Thoroughly clean ductwork inside and outside before grilles are installed.

V. PAINTING

1. This contractor shall obtain the services of a painting sub-contractor as part of contract with the General Contractor for all painting.

2. General: Except for standard factory finishes, all pipe, pipe covering, ducts, equipment, supports, hangers, etc., exposed inside and outside building or in equipment room shall be painted. This contractor shall prepare surface of material to receive first coat of paint. All subsequent coatings shall be prepared by Painting Subcontractor. Requirements covering paints, workmanship and preparation of surfaces as stated in Architectural Specifications shall govern. Color coding shall be approved by Architect (submit color sample). All submittals for review shall be through Architect.
3. Damage: Where standard equipment factory finishes have been damaged or scratched, the damaged area shall be repaired or replaced by the contractor to match the original finish.
4. Preparation: Thoroughly clean surfaces of all rust, scale, cement, and dirt from all equipment, piping or other work installed and leave ready for finish painting.
5. All exposed piping shall be painted. Paint with two (2) coats of paint. The color shall be industry standard color coding. Submit color code chart with sample color chips to Architect for review prior to starting work

W. FIRESTOPPING

1. Penetrations through rated construction shall be sealed with a material capable of preventing the passage of flames and hot gases when tested in accordance with ASTM-E14.
2. Notify Architect for inspection of all completed fire and/or smoke barrier walls before any construction is installed that may conceal the firestopping material installation.
3. Access to random selected areas may be required by the architect at the time of final inspection should notification not be given.
4. Provide detailed instructive cutsheets of fire penetration sealing system (firestopping) used to the architect at the time of inspection. Random selective sampling by the contractor will be observed by the architect and State Fire Marshal.

X. NOISE VIBRATION

1. General: Take the utmost precautions in the installation of the equipment, piping, and duct systems to prevent noise and vibration transmission.
2. Isolation of equipment: Equipment that would tend to cause noise or vibration shall be isolated to prevent noise transmission to the building or to other equipment.

3. Equipment Connections: Piping, conduit, or other connections to equipment shall be isolated. The contractor shall be responsible for the prevention of noise and vibration transmission through these connections to equipment.

Y. PERMITS, INSPECTIONS AND TESTS

1. Contractor shall obtain and pay for permits, fees, etc., for the installation, inspection, service connections, verifying location or construction of the work which are required by any authority and/or agencies having jurisdiction.

Z. TRAINING OF MAINTENANCE PERSONNEL

1. Contractor shall provide on the job training for Owner's personnel upon completion of the work including testing and adjustment. Minimum 12 hours of onsite training shall include maintenance checks, lubrication of components, adjustment of control set points, and troubleshooting techniques of the air conditioning unit.

AA. OPERATION AND MAINTENANCE INSTRUCTIONS

1. Provide Owner with four (4) copies of printed instructions indicating various pieces of equipment by name and model number complete with parts lists and maintenance and repair instructions. This information shall be bound in plastic covered notebooks. Submit the manuals to the Architect for approval.
2. Include all warranty certificates or statements in a separate section of the manuals. Provide all materials and test certificates for the final inspection.
3. Provide three (3) sets of DVDs of the operation and maintenance manuals.

BB. GUARANTEE

1. Contractor shall guarantee all materials, equipment and workmanship for a period of one year from the date of final acceptance of the project. This guarantee shall include furnishing of all labor and material necessary to make any repairs, adjustments or replacement of any equipment, parts, etc., necessary to restore the project to first class condition. This guarantee shall exclude only the changing or cleaning of filters.
2. If the contractor's office is in excess of a 50 mile radius of the project, he shall appoint a local qualified contractor to perform any emergency repairs or adjustments required during the guarantee period. The contractor appointed to provide emergency services shall be submitted to the Architect for his approval.

CC. WARRANTIES

1. Assemble warranties executed by each of the respective manufacturers, suppliers, and subcontractors into a warranty book and prepare a table of contents.
2. Two (2) original signed copies of each warranty are required.
3. Provide complete information for each item including:
 - a. Product and work item.
 - b. Local supplying firm or manufacturer's dealer, with name of principal, address and telephone number.
 - c. Scope of warranty.
 - d. Date of beginning of warranty.
 - e. Duration of warranty.
 - f. Provide information for Owner:
 - 1) Proper procedure to evoke the warranty in case of failure.
 - 2) Instances which might affect the validity of the warranty.
 - g. Contractor, name of responsible principal, address and telephone number.
 - h. All contractors and manufacturers equipment warranties shall start at the acceptance of the project by the Owner.
 - i. Provide owner with contact information for warranties which extend beyond one year.

DD. RECORD DRAWINGS

1. The Contractor shall obtain at his cost, two sets of black-line prints of the original bid documents by the Owner. One set shall be kept on the site with all information as referenced below and shall update same as the work progresses. The other set will be utilized to record all field changes to a permanent record copy for the Owner.
2. If the Contractor elects to vary from the Contract Documents and secures prior approval from the Owner for any phase of the work, he shall record in a neat and readable manner, ALL such variances on the black-line print in red. The original blue lines shall be returned to the Owner for documentation.
3. All deviations from sizes, locations, and from all other features of the installations shown in the Contract Documents shall be recorded.
4. In addition, it shall be possible using these drawings to correctly and easily locate, identify, establish sizes of all piping, directions, and the like, as well as other features of the work which will be concealed underground and/or in the finished building.

5. Locations of underground work shall be established by dimensions to columns, lines, or walls, locating all turns, etc., and by properly referenced centerline or invert elevations and rates of fall.
6. For work concealed in the building, sufficient information shall be given so it can be located with reasonable accuracy and ease. In some cases, this may be by dimension. In others, it may be sufficient to illustrate the work on the drawings in relation to the spaces in the building near which it was actually installed. The Owner's decision in this matter will be final.
 1. The following requirements apply to all "As-Built" drawings:
 2. They shall be maintained at the Contractor's expense.
 3. All such drawings shall be done carefully and neatly, and in a form approved by the Owner.
 4. Additional drawings shall be provided as necessary for clarifications.
 5. These drawings shall be kept up-to-date during the entire course of the work and shall be available upon request for examination by the Owner; and when necessary, to establish clearances for other parts of the work.
 6. "As-built" drawings shall be returned to the Owner upon completion of the work and are subject to approval of the Owner.

EE. MANUFACTURER'S DIRECTION

1. The mechanical contractor shall install and operate all equipment and materials in strict accordance with the manufacturer's installation and operating instructions. The manufacturer's instructions shall become part of the Contract Documents and shall supplement the Drawings and Specifications.
2. Store equipment in a clean, dry place protected from other construction. While stored, maintain factory wrapping or tightly cover and protect equipment against dirt, water, construction debris, chemical, physical, or weather damage, traffic, and theft.

FF. DEMOLITION

1. This contractor shall do all demolition as shown on the plans. The contractor shall make the areas ready for the new construction work. All demolition debris, piping, equipment, etc., shall be removed from the site by this contractor. All demolition work shall be scheduled through the General Contractor to prevent interruption of any existing services. Do not start any demolition which would interrupt the building operation without scheduling with the Owner (schedule through the General Contractor).
2. The Owner shall retain first salvage rights to anything within the demolition area. If the Owner selected an item to be retained, then this contractor shall remove it with care and deliver the item to the Owner

designated location on site. Anything not retained by the Owner shall become the property of the contractor and be removed from the site.

GG. MATERIALS CONTAINING HAZARDOUS SUBSTANCES OR COMPONENTS

1. This contractor shall not provide any material or component of equipment which contains asbestos, lead based paint or PCBs. The contractor shall provide certificates or manufacturer's statements/letters to show that the products and/or building materials do not contain asbestos, lead based paint or PCBs.
2. If any product or building material is found to contain asbestos, lead based paint or PCBs, the contractor shall bear all cost for removal, abatement, and disposal of materials in accordance with all state and federal regulations. The contractor shall install replacement materials to the satisfaction of the Architect at no additional cost to the project.
3. During the construction, if the contractor suspects that any material in the building contains or is a hazard material (asbestos, lead, PCB, mercury, etc.) work shall be stopped to prevent disturbance and the Owner shall be notified immediately.

END OF SECTION 23 05 00

SECTION 23 05 03 - BASIC MATERIALS AND METHODS FOR HVAC

I. GENERAL

A. DESCRIPTION

1. Type of piping for various systems shall be as specified herein.
2. All pipe shall be true and straight without sags or traps.

II. MATERIALS

A. REFRIGERANT PIPING/EQUIPMENT DRAIN PIPING

1. All refrigerant and equipment drain piping shall be government type "L" hard copper tube standard weight and thickness as made by Mueller, Chase, Anaconda or equivalent, unless indicated otherwise. Use Silfos 1000 degrees Fahrenheit solder on all joints.
2. Tubing shall be brought to the site with ends sealed.

B. A/C CONDENSATE DRAIN PIPING

1. All A/C condensate drain piping shall be government type "L" hard copper water tube of standard weight and thickness. Fittings shall be compatible with pipe. Use Silfos 1000 degrees Fahrenheit solder on all joints.

C. PIPE FITTINGS

1. All pipe fittings shall be same as piping specified unless indicated otherwise.
2. Fittings for refrigerant piping and other copper lines shall be solder type wrought copper, Nibco or equivalent.

D. PIPE SPECIALTIES

1. Dielectric unions shall be used between copper and iron pipe.

E. PIPE HANGERS AND SUPPORTS

1. This contractor shall furnish and install all foundations and supports required for his equipment unless indicated otherwise on the drawings.
2. This contractor shall furnish and install all escutcheons, inserts, thimbles, hangers, etc., required for the proper support and installation of his equipment and piping. Cooperate with other trades in locating and placing these items.

3. Provide sleeves for all pipes passing through walls, floors, beams, etc. Sleeves passing through structural members shall be of cast iron or Schedule 40 steel pipe unless other material is approved by the Structural Engineer. Sleeves passing through nonstructural walls or floors shall be of Schedule 10 galvanized iron. Joints between sleeves and pipes passing through floors shall be made watertight with plastic materials. Where pipes pass through floors shall be made watertight with plastic materials. Where pipes pass through waterproofing membrane, flashing sleeves shall be installed.
4. Provide malleable iron split ring hangers with rod supports throughout. Strap hangers or wire will not be accepted. Maximum spacing of hangers for cast iron pipes shall be 5 feet; for other than soil, use 10 feet.
5. Provide galvanized iron shields between hangers and pipe covering.
6. Provide chrome plated brass escutcheons wherever pipes pass through floors, walls or ceilings in exposed or finished areas.
7. All piping projecting from chases shall be rigidly supported in the wall or chase. Loosely supported piping or accessories will not be accepted.

F. MOTORS STARTERS AND ELECTRICAL WORK

1. The Mechanical Contractor shall furnish to Electrical Contractor for installation, all motor starters, start-stop push buttons and pilot lights for each piece of motor driven equipment unless shown otherwise.
2. The Electrical Contractor shall install all motor starters, start-stop push buttons and pilot lights as furnished by the Mechanical Contractor. The Electrical Contractor shall do all power wiring required for the installation of all mechanical equipment including equipment interlocking power wiring, etc. Temperature control wiring shall be furnished and installed by the Mechanical Contractor. All work shall be done in accordance with the National Electrical Code requirements and with wiring workmanship, etc., as called for in the Electrical Specifications. The Mechanical Contractor shall provide approved wiring diagrams of all equipment, controls, etc., to the Electrical Contractor for his installation. Coordinate all work to provide a complete system in working order. All wiring shall be plenum rated.
3. All electrical equipment shall have UL label or ETL label and shall meet the standards of the National Electrical Code and NEMA.
4. Mechanical contractor shall provide and install all duct detectors. The electrical contractor shall provide and install all wiring/interlocks with fire alarm.

G. ACCESS PANELS

1. Furnish and install access panels where valves, dampers, etc., are concealed in walls, ceilings, floors or otherwise inaccessible. Panels shall be Milcor, Babcock, Larsen, MIFAB, Acudor, Nystrom or equivalent. All access panels shall be minimum 18 inches X 18 inches hinged with flush latch and lock. The panels shall be primed and painted color as selected by Architect. Frame flange shall be minimum 1-1/2 inches wide. Rated panels shall have U.L. rating for type wall or ceiling where located.
2. Access panels located in rated walls, floors, or ceilings shall be so rated and installed per manufacturer's recommendations to maintain rated integrity.

III. EXECUTION

A. PIPING

1. Perforated strap hangers shall not be allowed for any part of the hangers.
2. Piping shall be installed as indicated on the drawings. Pipe shall be cut accurately to measurements established at the building and shall be worked into place without springing or forcing. Care shall be taken not to weaken structural portions of the building. Above ground piping shall be run parallel with the lines of the building unless otherwise shown or noted on the drawings. Service pipes, valves, and fittings shall be kept a sufficient distance from other work and other services to permit not less than 1/2 inch between finished covering and other work and not 1/2 inch between finished covering on the different services.
3. Expansion and contraction of piping: Allowance for expansion and contraction shall be made throughout. Sufficient flexibility shall be provided for expansion and contraction of piping. Flexibility shall be provided by installing one or more turns in the line so that the piping will spring enough to allow for expansion without straining.
4. Joints: Tubing shall be cut square, and butts shall be removed. Both inside of fittings and outside of tubing shall be well cleaned with steel wool before sweating. Care shall be taken to prevent annealing of fittings and hard drawn tubing when making connections. Installation shall be made by competent workmen in accordance with manufacturer's recommendation. Mitering of joints for elbows and notching of straight runs of pipe for tees will not be permitted. Joints for soldered fittings shall be made with a noncorrosive paste flux and solid string of wire solder. Cored solder will not be permitted.
5. Pipe sleeve, hangers, and fixture supports: These items shall be furnished and set and the contractor shall be responsible for their proper and permanent location.

- a. Pipe sleeves - Install sleeves for all pipes passing through footings, floors, and walls. Clearance between sleeves and pipe covering and/or pipes shall be approximately 1/4 inch. Construction shall not be cut except where approved by the Architect. Where cutting of construction is permitted, the construction shall be repaired to match its original condition. Sleeves shall not be installed in structural members except where indicated. Sleeves are not required for wall hydrants.
 - 1) Install sleeves for pipes that pass through walls. Sleeves that pass through walls shall be cut flush with surfaces. The space between sleeves and pipe or covering shall be sealed with graphite packing and synthetic rubber caulking compound.
 - 2) Install sleeves where pipes pass through waterproofing membrane. The sleeves shall be provided with an integral flashing flange or a clamping device to which a 4 pound lead flashing shield shall be clamped or soldered. The shield shall extend 12 inches from the pipe and shall be thoroughly mopped into the membrane. The space between the sleeve and pipe shall be made watertight by inserting an oakum gasket, filling the remaining space with lead, and thoroughly caulking.
 - b. Threaded pipe - Support pipes at 7 foot intervals.
 - c. Copper tubing - Support tubing at not more than 5 foot intervals. Hangers for copper tubing except where protective shields are installed shall have proper size rings to suit outside diameter of tubing and the hangers or supports shall be copper or copper plated at contact surfaces.
 - d. Underground piping - Lay pipe on a firm bed for its entire length, except where support is otherwise provided.
 - e. Vertical piping - Supports shall be at each floor. Horizontal piping - Hangers and supports shall be installed at locations not more than 3 feet from the end of each run out. A hanger shall be installed not over 1 foot from each change in direction of piping.
6. Unions: Make connections to equipment and branch mains with unions. Provide nonconducting type connections wherever jointing dissimilar metals in open systems. Brass adapters and valves are acceptable.

END OF SECTION 23 05 03

SECTION 23 05 93 - TESTING, ADJUSTING, AND BALANCING FOR HVAC

I. GENERAL

A. RELATED DOCUMENTS

1. All Division 23 Specification Sections, drawings, and general provisions of the contract apply to work of this section, as do other documents referred to in this section.

B. SCOPE OF WORK

1. The Mechanical Contractor shall obtain the services of an independent test and balance company which specializes in the testing and balancing of heating, ventilating and air conditioning (HVAC) systems to test, adjust and balance all HVAC systems in the building(s). These services shall not be provided by the installing mechanical contractor on the project but shall be a direct subcontractor of the mechanical contractor.
 - a. Agency shall provide proof of having successfully completed at least five projects of similar size and scope. Work by this Agency shall be done under direct supervision of a qualified Heating and Ventilating Technician employed by Agency.
 - b. Instruments used by Agency shall be accurately calibrated and maintained in good working order.
 - c. If requested, conduct tests in presence of Engineer.
 - d. Agency shall be approved in writing by Engineer. Mechanical Contractor shall not be permitted to do this work. Submit qualifications for review.
2. The work included in this section consists of furnishing labor, instruments, and tools required in testing, adjusting and balancing the HVAC systems, as described in these Specifications or shown on accompanying drawings. Services shall include checking equipment performance, taking the specified measurements, and recording and reporting the results. Refer to Plumbing Division 22 for additional work required of Air System Test and Balance agency.
3. Representatives of the test and balance company shall visit the job site to review the installation. After each site visit, the test and balance company shall report to the Architect any items that are not installed properly, are missing from the Contract Documents or items that are required to enable him to perform the testing and balancing of the HVAC systems as per normal standard practice. After review, the Architect shall instruct the contractor to implement the recommendations at no additional cost to the Owner if these items were specified in the original scope of the project.
4. Upon completion of the HVAC system installation, the test and balance company shall perform all testing and balancing with the full cooperation

of the contractor and his subcontractors. The contractor shall make changes and/or adjustments to the HVAC system components that are required by the test and balance company to accomplish proper balancing. The TAB agency shall not supply or install any materials or balancing devices such as pulleys, drives, belts, etc. All of this work by the contractor shall be performed at no additional cost to the Owner.

5. **Balancing agency shall be represented at final inspection meeting by qualified testing personnel with balancing equipment and two (2) copies of air balancing test report.**
6. The test and balance report shall be submitted to the Architect for review by his Mechanical Engineer. If the Mechanical Engineer agrees with the report, he shall sign it and return it to the Architect. If he does not concur with the report, he shall meet with the Test and Balance Company to determine what needs to be done to obtain a properly balanced system.
7. After the Mechanical Engineer signs the testing and balancing report, the Test and Balance Company shall supply four (4) copies of the final and complete report to the Architect for inclusion in the Operation and Maintenance Manuals.

C. The items requiring testing, adjusting, and balancing include (but are not restricted to) the following:

1. AIR SYSTEMS:
Air Handling Units/Split Systems
Zone Branch and Main Ducts
Diffusers, Registers, Grilles and Dampers
Coils (Air Temperatures)
Valves
Vibration Isolators
Duct Smoke/Pressure Leak Testing

D. SCHEDULING

1. Contractor shall award test and balance contract to approved agency upon receipt of his contract to proceed to allow Agency to schedule this work in cooperation with other Sections involved and comply with completion date.

E. DEFINITIONS, REFERENCES, STANDARDS

1. All work shall be in accordance with the latest edition of the Associated Air Balance Council (AABC) National Standards or the latest standards of the National Environmental Balancing Bureau (NEBB). If these contract documents set forth more stringent requirements than the AABC National Standards or the NEBB Standards, these contract documents shall prevail.

F. QUALIFICATIONS

1. Agency Qualifications: The TAB agency shall be a current member of the AABC, NEBB or TABB.
2. Prior to working on this project, the technicians shall attend training provided by the manufacturer of the various equipment on this project on the specific aspects of balancing the equipment. Include letters or certificates from the manufacturer on attendance and satisfactory completion of the factory training. These certifications may be used for continuing education. At a minimum, the technicians shall receive training from the air distribution equipment manufacturer, air terminal unit manufacturer, air unit manufacturer, pump manufacturer, air cooled chiller manufacturer and temperature controls manufacturer. This should be done prior to any equipment start-ups.
3. Although acceptable to be bidding the project the TAB agency shall provide qualifications and certifications to provide the required services.

G. SUBMITTALS

1. Qualifications: The TAB agency shall submit a company resume listing personnel and project experience in air and hydronic system balancing and a copy of the agency's test and balance engineer or technician certificate.
2. Procedures and Agenda: The TAB agency shall submit the TAB procedures and agenda proposed to be used.
3. Sample Forms: The TAB agency shall submit sample forms, which shall include the minimum data required by the AABC National Standards or the NEBB Standards.
4. Submit continuing education training on each lead technician working on the project.

H. TAB PREPARATION AND COORDINATION

1. Shop drawings, submittal data, up-to-date revisions, change orders, and other data required for planning, preparation, and execution of the TAB work shall be provided when available and no later than 30 days prior to the start of TAB work.
2. System installation and equipment startup shall be witnessed by the TAB agency. The TAB Agency's final Test and Balance shall begin when all factory start-ups are complete.
3. The building control system (BCS) contractor shall provide and install the control system, including all temperature, pressure and humidity sensors. These shall be calibrated for accurate control. If applicable, the BCS

contractor shall install all necessary computers and computer programs, and make these operational. Assistance shall be provided as required for reprogramming, coordination, and problem resolution. The BCS contractor shall provide all necessary software to the TAB Agency at no additional cost.

4. All test points, balancing devices, identification tags, etc., shall be accessible and clear of insulation and other obstructions that would impede TAB procedures.
5. Qualified installation or startup personnel shall be readily available for the operation and adjustment of the systems. Assistance shall be provided as required for coordination and problem resolution.
6. If, upon commencing the work, the TAB contractor finds that the systems are not ready, or if a dispute occurs as to the readiness of the systems, the TAB contractor may request an inspection to be made by the Designer's Mechanical Engineer. This inspection shall establish to the satisfaction of the represented parties whether or not the systems meet the basic requirements for testing and balancing. Items that are determined to be not ready for testing and balancing shall be completed by the Mechanical Contractor and placed in operational readiness before TAB services are again requested.

I. TAB REPORTS

1. Final TAB Report: The TAB agency shall submit the final TAB report for review by the Engineer. On plans provided, all outlets, devices, HVAC equipment, etc., shall be identified, along with a numbering system corresponding to report unit identification. The TAB agency shall submit an AABC or NEBB "National Project Performance Guaranty" assuring that the project systems were tested, adjusted and balanced in accordance with the project Specifications and AABC or NEBB National Standards.
2. Submit four (4) copies of the final TAB report to the Architect for inclusion in the Operation and Maintenance Manuals.

II. INSTRUMENTATION

- A. All instruments used for measurements shall be accurate and calibrated. Calibration and maintenance of all instruments shall be in accordance with the requirements of AABC or NEBB National Standards.

III. EXECUTION

A. GENERAL

1. Mechanical Contractor shall put heating, ventilating, and cooling systems and equipment into full operation and continue their operation during each working day of testing and balancing.
2. Air Balance and Testing Agency shall perform tests specified, compile test data, and submit four (4) copies of complete test data to contractor for forwarding to Engineer for evaluation and approval.
 - a. Approved copies of report shall be bound in Operations and Maintenance manuals.
3. System shall be completely balanced and all reports submitted to Engineer prior to prefinal inspection.
4. The specified systems shall be reviewed and inspected for conformance to design documents. Testing, adjusting and balancing on each identified system shall be performed. The accuracy of measurements shall be in accordance with AABC or NEBB National Standards. Adjustment tolerances shall be + or -10 percent unless otherwise stated.
5. Equipment settings, including manual damper quadrant positions, valve indicators, fan speed control levers, and similar controls and devices shall be marked to show final settings.
6. All information necessary to complete a proper TAB project and report shall be per AABC or NEBB standards unless otherwise noted. The descriptions of work required, as listed in this section, are a guide to the minimum information needed.
7. TAB contractor shall cut insulation, ductwork and piping for installation of test probes to the minimum extent necessary to allow adequate performance of procedures. Upon completion, patch insulation, ductwork and housings using materials identical to those removed. Seal insulation to reestablish integrity of the vapor barrier.
8. TAB work shall include additional inspection and adjustment of components during the season following the initial balance to include re-balance of any items influenced by seasonal changes or as directed by the Owner.

B. AIR SYSTEMS

1. TESTING PROCEDURE
Air Balance and Testing Agency shall perform following tests and balance system in accordance with following requirements. Perform the following tests at high and low speeds of multi-speed systems and single speed system.

- a. **Make periodic inspections of the installation of the systems. Provide reports of each inspection. Inspections should be monthly when ductwork installation begins. Coordinate and verify the installation of all balancing dampers, fire dampers, etc.**
- b. Smoke test or pressure test each low pressure steel duct system to test for air tightness. Use zinc chloride smoke candles or titanium tetrachloride ampules (sticks) to generate smoke.
- 1) If ducted systems leak, do not continue with air balance. Report findings to Engineer in writing and begin testing again after Mechanical Contractor has repaired ducts or applied duct sealers.
 - 2) If ducted systems appear air tight, proceed with air balance procedure as outlined below.
 - 3) Include in air balance report a letter indicating smoke testing has been accomplished and a report of findings regarding airtightness of each ducted system.
 - 4) Maximum leakage loss shall not exceed 2 percent. If losses are greater, the Mechanical Contractor shall correct the leakage, then the test and balance agency shall retest the ductwork.
- c. Test and adjust blower rpm to design requirements.
- d. Test and record motor full load amperes.
- e. Make Pitot Tube traverse of main supply and return and obtain design cfm.
- f. Test and record system static pressures, suction, and discharge.
- g. Test and adjust system for design cfm air.
- h. Test and adjust system for design cfm outside air.
- i. Test and record entering air temperatures (db heating and cooling).
- j. Test and record entering air temperatures (wb cooling).
- k. Test and record leaving air temperatures (db heating and cooling).
- l. Test and record leaving air temperatures (wb cooling).
- m. Adjust main supply and return air ducts to proper design cfm.
- n. Adjust zones to proper design cfm, supply and return.
- o. Test and adjust each diffuser, grille, and register to within 10 percent of design requirements.
- p. Identify each diffuser, grille, and register to location and area.
- q. Identify and list size, type, and Manufacturer of diffusers, grilles, registers, and testing equipment. Use Manufacturer's rating on equipment to make required calculations.
- r. In readings and tests of diffusers, grilles, and registers, include required fpm velocity and test fpm velocity and required cfm and test cfm after adjustments.
- s. In cooperation with Mechanical Contractor, set adjustments of automatically operated dampers to operate as specified, indicated, or noted.
- t. Adjust diffusers, grilles, and registers to minimize drafts.
- u. Verify the calibration of temperature control devices, thermostats, etc.

- v. Verify all control sequences with specifications.
 - w. Include manufacturer's performance data with reports.
 - x. Schedule three (3) inspections to verify original test and balance of systems within 90 days of acceptance by Owner. Make opposite season adjustment and inspection of systems at one year after acceptance by Owner. Submit reports after each inspection. Submit schedule as part of initial report. Submit schedules as part of initial report.
2. Where systems supplied to job site provides over 5 percent more air than schedule requirements, rooms supplied by that system shall have their supply air quantities increased by the ratio of the actual total air quantity supplied to the minimum air quantity required by the schedule.
 3. The TAB agency shall verify that all ductwork, splitters, extractors, dampers, grilles, registers, and diffusers have been installed per design, are functional and set full open. Any leakage in the ductwork shall be repaired prior to the test. The TAB agency shall perform the following TAB procedures in accordance with the AABC National Standards or NEBB Standards:
 - a. Fans
 - 1) Fan Speeds--Test and adjust fan RPM to achieve design cfm requirements.
 - 2) Current and Voltage--Test and record motor voltage and amperage, and compare data with the nameplate limits to ensure fan motor is not in or above the service factor.
 - 3) Pitot-Tube Traverse--Perform pitot-tube traverse of the main ducts to obtain total CFM. If a pitot-tube traverse is not practical, an explanation of why a traverse was not made must appear on the appropriate data sheet.
 - 4) Static Pressure--Test and record system static pressure, including the static pressure profile of each fan.
 - b. Zone, Branch, and Main Ducts
 - 1) Adjust ducts to within design cfm requirements. As applicable, at least one zone balancing damper shall be completely open. Multi-diffuser branch ducts shall have at least one outlet or inlet volume damper completely open.
 - c. Diffusers, Registers, and Grilles
 - 1) Tolerances--Test, adjust, and balance each diffuser, grille, and register to within 10 percent of design requirements. Minimize drafts.
 - 2) Identification--Identify the type, location, and size of each grille, diffuser and register. This information shall be recorded on air outlet data sheets.
 - d. Coils
 - 1) Air Temperature--Once air flow is set to acceptable limits, take wet bulb and dry bulb air temperatures on the entering and leaving side of each cooling coil. Dry bulb

temperature shall be taken on the entering and leaving side of each heating coil.

- e. Heat Pump Units--Indoor Section:
 - 1) Location, manufacturer, model number, serial number, and manufacturer. Required and test data with unit operating at full air flow conditions (all space thermostats calling for cooling) for each of following: total CFM, return and outside air CFM, total static pressure, suction and discharge static pressures across unit fan, HP, amperage, voltage, fan RPM. Verify performance controls.
- f. Heat Pump--Outdoor Section:
 - 1) Both specified and test data for each unit. Verify voltage specified and actual. Full load amps at outdoor conditions. Refrigerant charge.
- g. Control Systems:
 - 1) Verify all control sequences and calibration of all thermostats and sensors.

C. ADDITIONAL TAB SERVICES

- 1. Job Site Inspections:

During construction, the TAB agency shall inspect the installation of pipe systems, sheet metal work, temperature controls, and other component parts of the HVAC systems. The TAB agency shall submit a written report of each inspection to the Architect.
- 2. Duct Leakage Testing:

The Installing Contractor shall isolate and seal sections of ductwork for testing. The pressurization fan and test apparatus shall be connected to the test section and the test performed. The test pressure required and the amount of duct to be tested shall be described by the engineer in the appropriate duct classification section. All testing shall be based on one test per section.
- 3. Verification of HVAC Controls:
 - a. The TAB agency shall be assisted by the building control Systems Contractor in verifying the operation and calibration of all HVAC and temperature control systems. The following tests shall be conducted:
 - b. Verify that all control components are installed in accordance with project requirements and are functional, including all electrical interlocks, damper sequences, air and water resets, fire and freeze stats, and other safety devices.
 - c. Verify that all controlling instruments are calibrated and set for design operating conditions.
- 4. Temperature Testing:

To verify system control and operation, a series of three (3) temperature tests shall be taken at approximately 2 hour intervals in each separately controlled zone. The resulting temperatures shall not vary more than 2 degrees Fahrenheit from the thermostat or control set point during the tests. Outside temperature and humidity shall also be recorded during the testing periods.

5. TAB Report Verification:
At the time of final inspection, the TAB agency may be required to recheck, in the presence of the Owner's representative, specific and random selections of data, air quantities, and air motion recorded in the certified report. Points and areas for recheck shall be selected by the Owner's representative. Measurements and test procedures shall be the same as approved for the initial work for the certified report. Selections for recheck, specific plus random, will not exceed 10 percent of the total number tabulated in the report.

END OF SECTION 23 05 93

SECTION 23 07 00 - MECHANICAL INSULATION

I. GENERAL

A. DESCRIPTION

1. Pipe insulation installation shall not begin until all work has been tested and found to be tight. All insulation shall be UL listed and have a flame spread of less than 25 and a developed smoke rating less than 50. All insulation shall be banded with aluminum bands, three per section. All insulation shall be continuous through walls, floors, ceilings, etc.

II. MATERIALS

A. CONDENSATE DRAIN PIPING

1. All condensate drain lines shall be insulated with ½" thick flexible closed cell elastomeric thermal tube pipe insulation as manufactured by Armaflex AP, Rubatex or prior approved equal. All joints are to be firmly butted together. All lap and butt joint strips are to be sealed in place with vapor barrier adhesive. Fittings are to be mitered segments of insulation held in place with vapor barrier sealant. Engineered Polymer Foam Insulation (EPFI) will not be accepted. Insulation shall be applied in accordance with manufacturer's recommendations and instructions. Insulation shall be rated for use in return air plenum applications.
2. All condensate drain lines run in an area exposed to the weather shall be covered with 1" Armaflex tube insulation. All joints and seams shall be glued per manufacturer's recommendations. Cover insulation with Venture Clad 1577CW multi-layered laminate coated, acrylic pressure sensitive adhesive jacket system.

B. REFRIGERANT LINES

1. Insulate with close cell elastomeric thermal tube insulation as manufactured by Armaflex AP, Rubatex or prior approved equivalent. All joints are to be firmly butted together. All lap and butt joint strips are to be sealed in place with vapor barrier adhesive. Fittings are to be mitered segments of insulation held in place with vapor barrier sealant. Engineered Polymer Foam Insulation (EPFI) will not be accepted. Insulation shall be applied in accordance with manufacturer's recommendations and instructions. Thickness shall be as follows: exterior 1-1/2" thick, interior up to 1" thick.
2. Apply two coats of weatherproof mastic on all piping below grade or exposed to weather.

3. All refrigerant lines on the outside of the building exposed to the weather shall be covered with Venture Clad 1577CW multi-layered laminate coated, acrylic pressure sensitive adhesive jacket system.

C. EQUIPMENT ROOM WALLS

1. Provide sound absorbing 1 inch thick 3 pound density semi-rigid fiberglass board. The board shall be faced with 8 mil triple-ply laminate composed of a white polypropylene face, with a fiberglass scrim, and an aluminum foil back, all laminated with a flame retardant adhesive. The fiberglass board and the facing shall meet flame spread of not greater than 25, and a smoke developed rating of not greater than 50.
 - a. Insulation shall be installed by impaling on stick-pins with a suitable adhesive (no self stick pins may be used). After material is impaled on pins, the tip of the pin shall be covered with a white dome-cap washer. All joints, corners, and exposed edges shall be covered with the facing material. Remove and replace any damaged insulation with new material.

D. AIR CONDITIONING DUCTWORK

1. Insulate all ducts above ceiling with one layer of 2.2 inch thick, 3/4 pound density flexible Fiberglass duct insulation with aluminum foil facing. Duct insulation to be applied with 2 inches lap of facing sealed with tape and outward clinch staples. Seal all joints with 2 inch wide vapor barrier tape. An additional band of tape shall be applied between the circumferential joints for a maximum 2 foot spacing of taped bands.
2. The ductwrap shall have a minimum installed R-value of 6.0 and shall comply with Energy Code requirements.

E. INSULATION BANDS

1. All pipe insulation shall be banded with nylon tie-wrap bands, three (3) to a section, and with one band on each side of each fitting, valve, etc.

F. FLANGES, VALVES AND FITTINGS

1. All flanges, valves and fittings shall be insulated with fabricated fiberglass molded fitting insulation, using factory fabricated fittings up to 3 inches and fabricated mitered segments of pipe insulation equal in thickness to the insulation to the adjoining pipe. All fabricated mitered segments shall be covered with matching embossed vapor barrier laminate.

III. INSTALLATION

- A. Provide clearance for installation of insulation and for access to valves, air vents, drains and unions.

1. Insulation Installation:
 - a. Do not install covering before piping has been tested and approved.
 - b. Ensure piping surface is clean and dry prior to installation.
 - c. Ensure insulation is dry before and during application.
 - d. Insulation shall be continuous through walls, floors and ceiling. Pack around pipes with fire proof self-supporting insulation material, fully sealed.
 - e. Insulate fittings and valves. The end of the insulation shall be fitted with a metal escutcheon plate with set screw or taped neatly with pressure sensitive fiberglass reinforcing cloth.
 - f. All joints shall be sealed with 3 inch wide fiberglass reinforcing cloth with pressure sensitive adhesive.
 - g. Pipe insulation at Hangers and Supports: Pipe insulation at hanger and support shall be protected with a half circular shield of the size of the insulation and 12 inches long constructed from 20 gauge galvanized steel. The shield shall be held in place with the fiberglass reinforcing cloth and pressure sensitive adhesive. Where pipes pass through walls, ceiling and floor in finished areas, escutcheon plates shall be installed to encompass pipe and insulation. Escutcheon plates shall be chromed brass or stainless steel and shall be either solid or the clamp on split type.
 - h. Painting of fiberglass pipe jacket is not required. Piping shall be painted colors as standard in this facility.

END OF SECTION 23 07 00

SECTION 23 09 00 - TEMPERATURE CONTROLS

I. GENERAL

A. GENERAL REQUIREMENTS

1. Refer to Section 23 05 00, Section 23 05 03, Section 23 30 00 and Section 23 70 00, provisions of which apply to work under this Section.
2. All control systems shall be furnished complete and functioning.
3. Coordinate all control work with the mechanical and electrical contractors. Contact the Test and Balance Contractor and notify them as to when controls work shall be installed. Test and Balance controller shall verify controls systems installation and proper operations.

B. DESCRIPTION OF WORK

1. Provide a complete system of "hard-wired" automatic controls (wireless unacceptable) as indicated herein. Control system shall consist of all thermostats, sensors, actuators, operators, wiring, switches, relays and control panels necessary to accomplish the control sequence specified herein.

C. RELATED WORK IN OTHER SECTIONS

1. For extent of power wiring and connection to mechanical equipment under Electrical Work, refer to Electrical Specifications.
2. For control devices furnished with equipment, refer to equipment specifications and schedules. Any controls equipment not specifically called for elsewhere shall be provided by controls contractor. All control wiring shall be done by controls contractor.
3. All power for control devices such as actuators, operators, fire/smoke dampers, control dampers, etc. shall be furnished, installed and wired by the Controls Contractor. Controls Contractor may use 24 VAC or 120 VAC for the control system. The controls contractor shall be responsible for obtaining the necessary power and pay all costs associated with obtaining power to controls and controls equipment.
4. All interior control wiring shall be installed in galvanized EMT conduit. The last 6 inches at connection to equipment shall be flexible metal conduit. All control wiring on exterior of building shall be in Seal-Tite conduit and/ or Liquid Tight flexible conduit.
5. All control wiring shall be furnished and installed by this contractor.

D. SERVICE

1. Installing Contractor (Mechanical Contractor or subcontractor under the Mechanical Contractors) shall maintain adequate automatic control personnel on his payroll to provide back-up project control service on the automatic control system provided under this contract.

E. WARRANTY

1. Contractor shall warranty all work performed under this contract to be free of any defects in workmanship or material for a period of 1 year after final acceptance by the Owner's representative. The warranty and extended warranty shall include quarterly calibration and set-up checks of all controls. THIS WARRANTY DOES NOT START ON DATE THAT THE MECHANICAL EQUIPMENT IS STARTED.

F. SUBMITTAL

1. Submit shop drawings and product data sheets indicating configuration, general assembly, and materials used in fabrication.
2. Submit manufacturer's installation instructions. Instructions shall include complete wiring diagrams drawn specifically for this project.

G. OPERATION AND MAINTENANCE

1. Include manufacturer's descriptive literature, operating instructions, and maintenance data.

H. QUALITY ASSURANCE

1. Manufacturer shall be a company specializing in products of the type specified in this section. All components shall be Class A quality commercial or industrial grade for installation in locations or environments shown on plans.

I. SYSTEM RESPONSIBILITY

1. The entire control system, shall be furnished by a single source manufacturer who shall be responsible for the entire system. The installation shall be by technicians employed by the controls system manufacturer.

II. PRODUCTS

A. FIRESTATS AND SMOKE DETECTORS

1. Duct smoke detectors shall be furnished and installed by mechanical contractor. Install a smoke detector in the supply air section/duct and return air section/ duct of each unit delivering over 2000 cfm to stop the

fan and close the outside air dampers in the event of excessive temperature or smoke. Firestats to be provided in the return air units of all units over 600 cfm.

2. Smoke detectors shall be addressable and compatible with the fire alarm system.
3. Where and when the building does not have a fire alarm system, provide a remote annunciator with remote reset for each detector.
4. All smoke detectors shall have remote reset.

B. WIRING

1. Factory mount and wire HVAC equipment controls. Mount electrical components in unit control box with removable cover. Provide clearance for access to controls (36 inch clearance).
2. Provide terminal strip(s) for field wiring of thermostat, communications and power source. DO NOT USE WIRE NUTS IN JUNCTION BOX.
3. All wiring shall comply with local and national electric codes and the manufacturer's published installation manual.
4. Provide terminal strip(s) for field wiring of air conditioning unit input connections, duct temperature sensor, velocity sensor, static pressure sensor, communications, start/stop devices, VFD controls, time clock, bypass damper motor and power wiring, etc. Do not use wire nuts on loose wire. All wire shall be in conduit, flexible conduit or wiring harness.

C. THERMOSTAT

1. Provide fully automatic room-type electronic programmable thermostat as indicated on plans to cycle outdoor unit on cooling cycle and heating cycles as required to maintain space conditions. Thermostat shall have the following features:
 - a. Designed for use with the type of system used.
 - b. "Auto-On" fan selector switch for constant or automatic fan operation.
 - c. "Auto-Off" selector switch to energize unit to fully automatic change-over from heating to cooling mode.
 - d. Temperature selector switch with concealed screw-type maximum set points for heating and cooling mode.
 - e. Thermostat shall be programmable for automatic temperature set-up or setback for occupied and unoccupied times minimum two per day.
 - f. Shall have an LED or LCD read out display.
 - g. Battery back-up should loss of building power occur.

- h. Button type or touch sensitive keypad for data entry in to the thermostat.
- i. Thermostat range of operation shall be 55 degrees Fahrenheit – 85 degrees Fahrenheit in heating or cooling mode.
- j. Thermostat shall maintain humidity setpoint. Humidity setpoint shall be adjustable by the user.

III. EXECUTION

A. INSTALLATION

- 1. Division 26, ELECTRICAL, shall be responsible for point to point wiring of all starters and starting switches not factory installed in the HVAC equipment.
- 2. Install all components of control systems under this Section using experienced control mechanics, all in the regular employ of the Installing Contractor, or the apparatus manufacturer.

B. WIRING

- 1. Install all control, pilot circuit and interlock wiring, including wiring through interposed safety or other auxiliary control devices within the confines of the mechanical equipment only. Wiring of thermostats shall be by the Mechanical Contractor.
- 2. All wiring shall conform to the Local and National Electrical Codes.
- 3. All control and interlock wiring shall be fused at conductor capacity as shown in the National Electrical Code.
- 4. No splices will be allowed except at junction boxes and control centers.
- 5. All wires to each control device must be different colors. All wires to each device must be laced or tied at point of entry into control panel and tagged as to its point of origin.
- 6. All wires shall be run directly from controller or controlled device to control center. There shall be no looping of wires from one device to another external to the control centers.
- 7. Control voltage shall be a maximum of 120-volt, unless otherwise indicated herein.
- 8. Control or interlock wiring shall not be run in conduit with any power wiring other than that serving the equipment controlled.
- 9. Refer to Division 26, ELECTRICAL, for extent of work under that Division. Provide other wiring systems required to accomplish the work

of this Section, following requirements of Division 26 for products and execution.

10. Wiring connection to terminal posts shall be made by means of compression type lugs. Wire splices shall be made with sketch locks.
11. Safety devices in motor control circuits shall be wired to interrupt the holding coil circuit regardless of the position of any selector switches in the circuit.
12. Control circuit conductors shall be sized for a maximum voltage drop of 10 percent of the circuit voltage.
13. All electrical power wiring shall conform in all respects with the provisions of the National Electrical Code and Division 26, ELECTRICAL, of the Specifications.
14. Provide all necessary contactors, switches, transformers to accomplish operating sequences.

C. SYSTEM CHECK-OUT

1. Check-out each system for control function through entire sequence, check calibration of instruments, reset instruments control points.
2. Owner maintenance personnel shall be made thoroughly familiar, by the contractor, with the operation and service of the project automatic temperature control circuits.

IV. SEQUENCE OF OPERATION

A. HEAT PUMP SYSTEMS

1. When thermostat switch is set in the "on" position, the indoor unit fan shall run continuously. When thermostat fan switch is set in the "auto" position, the indoor unit fan shall cycle with compressor operation.
2. The thermostat shall cycle the compressor(s) as required to maintain thermostat set points in heating or cooling thermostat shall switch modes automatically. Thermostat shall energize auxiliary strip heater as required during low outdoor ambient periods and defrost cycles.
3. Thermostat shall be programmable for occupied and unoccupied time periods and temperatures.
4. Indoor units shall be electrically interlocked such that neither outdoor unit nor auxiliary strip heaters may not be energized unless indoor unit fan is running.

5. Smoke detector shall de-energize indoor unit fan on sensing smoke in the supply duct leaving the indoor unit.
6. Firestats shall de-energize indoor unit fan on high return air temperature (125 degrees Fahrenheit).

END OF SECTION 23 09 00

SECTION 23 30 00 - AIR DISTRIBUTION FOR HVAC

I. GENERAL

A. GENERAL

1. Furnish and install all ducts for Air Conditioning, Heating, and Ventilating Systems as shown on the plans and as may be required to provide complete system. Ductwork shall be complete with grilles, vanes, flashings, hangers, flexible connections, splitters, manual dampers, fresh air inlets, louvers, reinforcing angles, etc. All ductwork shall be concealed and insulated as hereinafter specified.

B. COORDINATION

1. The General Contractor and Mechanical Contractor shall coordinate the space clearances required for ductwork with the structure, ceilings, lights, sprinklers, etc. In some cases, due to space limitations, it may be necessary to re-size ductwork to meet the conditions of the project. Any re-sizing required shall be part of this project and done without any additional cost to the project. DO NOT MAKE DUCTWORK WITHOUT COORDINATION.

- C. 1. Sealing or flashing the building envelope due to penetrations in the building shall be the responsibility of the general contractor.

II. MATERIALS

A. DUCT HANGERS AND SUPPORTS

1. All ductwork shall be properly braced to prevent rattling, breathing, or other unnecessary noise. No sharp edges or obstructions shall project into air stream.

B. LOW PRESSURE DUCTWORK

1. All ductwork shall be galvanized steel and shall be of gauges and construction as recommended by ASHRAE Guide and Data Book and SMACNA guidelines. Gauges are as follows with longest side governing.

Dimension of longest side	Low Pressure Ductwork Sheet Metal Gauge
0"-12"	26 gauge
13"-30"	24 gauge
31"-54"	22 gauge
55"-84"	20 gauge

2. Low pressure ductwork shall be all exhaust ducts, return air ducts, fresh air ducts and supply ducts.
3. Joints and reinforcing shall be as per ASHRAE Guide and Data Book and all slips shall be installed without edge of internal part of slip facing downstream.
4. Construction standard of Article 110, of the National Board of Fire Underwriters Bulletin 90, latest edition, shall apply throughout.
5. Flashings shall be of sheet copper and shall be furnished and installed around all outside openings used for ducts of fans and wherever required. Roof flashings shall extend at least 8 inches above roof.
6. All ducts shall be straight and true and installed in a neat and workmanlike manner.
7. All edges shall be straight and true and all bends shall be made with veined turns. Where long radius turns cannot be used, the contractor shall use square turns and use air splitters spaced not more than 3 inches center to center, and of a length so air will be properly distributed over ducts.
8. All ducts shown are metal to metal dimensions.
9. Mastic shall be applied to both male and female connections (all seams and joints) to make all duct joints air tight (applies to all ductwork; round or rectangular). Surplus mastic shall be removed. Tape and re-mastic joints if necessary. Mastic (hard-cast or equivalent duct sealer: tape not acceptable) shall be applied to the joints during assembly so that sealant is on all mating surfaces of the joint.

C. DUCT LINERS

1. Ductwork shall be lined with 1 inch thickness black neoprene coated glass fiber duct lining, where specified on plans. Lining material to be as made by Knauf, Johns Manville, Owens Corning or approved equivalent. Sheet Metal Contractor shall exercise care in cutting and fitting lining material to interior of duct. Cuts should be sharp and clean with joints and fits tight. Lining material is to be applied by buttering on back and edges of sheets with 1/8 inch FC-104 or equivalent, waterproof duct lining cement, cement applied with serrated trowel or similar tool so a grooved application of cement results. Lining material shall be treated with an anti-microbial growth agent compliant with ASTM C1338, G21, G22.
2. Lining material is to be further secured in place with sheet metal screws or grip nail fasteners automatic machine installed (no magnetic hammer) on 12 inch to 18 inch centers. These screws shall run from outside of duct through lining material and into rectangular sheet metal caps held in place against inside face of lining material.

D. FILTERS--PRIMARY

1. Units shall be equipped with low velocity filter section with 30 percent efficient 2 inches thick pleated type (Continental air filters "cono pleat" FARR 3030, American Air Filter or equal) throwaway filters.
2. Provide and install one set of filters as called for in these Specifications for initial testing and start-up and another complete set upon completion of the project.

E. DUCT ACCESSORIES

1. Dampers of the fusible link operated type shall be provided in all ductwork passing through floor or fire walls.
2. Provide quadrant or adjustable splitters and mark shaft to give position of splitter damper in duct.
3. Provide vanes behind every supply grille or diffuser. Splitters shall be provided where shown on plans and where located in concealed non-accessible space provided Young Regulators to operate splitter. Vanes shall be Tuttle and Bailey "Ducturns", Barber-Coleman, Uniflo, or equivalent. Shop fabricated vanes will be acceptable. All dampers shall be constructed of 14 gauge steel.

F. GRILLES AND DIFFUSERS

1. Ceiling supply outlets, unless otherwise indicated on plans shall be Anemostat/Waterloo, Metalaire, Krueger, Titus, Price, Nailor or approved equal. Outlets shall be mounted tight to the construction, and shall have frame suitable for type of ceiling used unless otherwise noted.
2. Return air grilles shall be as manufactured by Anemostat/Waterloo, Krueger, Metalaire, Titus, Price, Nailor or approved equivalent and shall be of style called for on plans.
3. All supply outlets shall have sponge rubber gaskets.
4. All grilles, diffusers, and registers shall be of sizes indicated on plans or scheduled on drawings.
5. Unless otherwise shown on drawings, all grilles installed in the ceiling shall be furnished with white baked-on enamel finish.

G. STATIONARY LOUVERS

1. Louver shall be manufactured by Ruskin HZ700, Greenheck EHV-901 or approved equal, AMCA 550 listed with horizontal blades on exterior face.

Louver shall meet AMCA 540 and AMCA 550 listing with the Air Movement and Control Association Certified Ratings Program.

2. Louver Construction

- a. Fabrication: Extruded aluminum stationary louver style.
 - 1) Frame: Double frame design.
 - a) Frame Depth: Exterior frame depth is 2 inches (51 mm) and interior frame depth is 6 inches (153 mm). Overall combined frame depth is 8 inches (203) nominal.
 - b) Wall Thickness: 0.060 inch (1.5 mm) and 0.095 inch (2.4 mm) nominal.
 - c) Material: Extruded aluminum, Alloy 6063-T6.
- b. Blades:
 - 1) Style: Sight proof.
 - 2) Material: Extruded aluminum, Alloy 6063-T6.
 - 3) Wall Thickness: 0.080 inch (2.1 mm) and 0.062 inch (1.6 mm) nominal.
 - 4) Blade Depth: Exterior blades are 2 inches (51 mm) deep, interior blades are 6 inches (153 mm) deep.
- c. Sill: Sill Flashing: Formed aluminum, 0.081 inch (2.0 mm), upturned sides to prevent water leakage.

3. Performance Data:

- a. Performance Ratings: AMCA licensed.
 - 1) Based on testing 48 inches by 48 inches (1219 mm by 1219 mm) size unit in accordance with AMCA 500.
- b. Free Area: 31 percent, nominal.
- c. Maximum Recommended Air Flow through Free Area: 2261 feet per minute (11.5 m/sec).
- d. Air Flow: 11,375 cubic feet per minute (322 cu. m/min).
- e. Maximum Pressure Drop (Intake): 0.45 inches w.g. (0.11 KPa).
- f. Louver shall be certified to Miami-Dade standards TAS 201 (Large Missile Impact), TAS 202 (Uniform Static Air Pressure) and TAS 203 (Cyclic Wind Loading).
- g. Wind load Test Performance: Maximum wind load of ± 130 PSF (6.22 kPa) design wind loads tested per Miami-Dade County Uniform Wind Pressure Test TAS 202.
- h. Wind-driven Rain Performance:
 - 1) Effectiveness Ratio: 99.9 percent effective at preventing water penetration through louver when tested at 50 miles per hour (81 km/h) wind with 8 inches per hour (203 mm/h) rainfall and 2261 feet per minute (11.5 m/sec) airflow through the free area. Penetration Class 'A' in accordance with AMCA 500-L Wind Driven Rain Test.
 - 2) Effectiveness Ratio: 99.9 percent effective at preventing water penetration through louver when tested at 29 miles

per hour (46.4 km/h) wind with 3 inches per hour (76 mm/h) rainfall and 2247 feet per minute (11.4 m/sec) airflow through the free area. Penetration Class 'A' in accordance with AMCA 500-L Wind Driven Rain Test.

4. Louvers shall be provided with rear mounted blade supports as required to comply with wind load criteria.
5. Insect Screens:
 - a. Aluminum: 18-16 mesh, mill finish, .011 inch (0.3 mm) wire.
 - b. Frame: Aluminum.
6. Finish: 70 percent PVDF: Finish shall be applied at 1.2 mil total dry film thickness. Color as selected by Architect from manufacturer's standard and custom color charts.

H. PRE-INSULATED FLEXIBLE DUCT

1. Flexible duct shall be rated for a maximum pressure of 16 inches (4-10 inches I.D.) or 10 inches (12-16 inches I.D.) water column positive pressure and 2 inches water column maximum negative pressure and 6000 FPM maximum velocity and listed by Underwriters Laboratories, Inc. under UL Standard 181 as a Class 1 air duct complying with NFPA Standards 90A and 90B. Flexible air duct shall be factory-made and composed of an inner duct of woven and coated fiber glass fabric providing an air seal and permanently bonded to coated steel wire helix, a fiber glass insulating blanket with minimum R-6.0 value (minimum 2 inch thickness) and low permeability outer vapor barrier of fiberglass reinforced metalized film laminate. Flexible air ducts shall be Thermaflex MK-C or Flexmaster type 4M. Maximum installed length shall not exceed 3 feet-0 inches without approval.

III. INSTALLATION

A. DUCTS

1. Ductwork shall be constructed and installed as follows:
 - a. Straight and smooth on inside with joints neatly finished unless otherwise directed.
 - b. Duct panels through 48 inch dimension having acoustic duct liner need not be crossbroken or beaded.
 - c. Crossbreak unlined ducts and duct panels larger than 48 inches or bead 12 inches on center.
 - d. Securely anchor ducts to building structure with specified duct hangers attached with screws.
 - e. Brace and install ducts so they shall be free of vibration under all conditions of operation.

- f. Ducts shall not bear on the top of structural member.
 - g. Make duct take-offs to branches, registers, grilles, and diffusers as detailed on Drawings.
 - h. Properly flash where ducts protrude above roof.
 - i. Install internal ends of slip joints in direction of flow. Make joints air tight using specified duct sealer.
- 2. Install flexible duct connections to each air handling unit.
 - 3. Provide each take-off with an adjustable volume damper to balance that branch.
 - a. Anchor dampers securely to duct.
 - b. Install dampers in main ducts within insulation.
 - c. Dampers in branch ducts shall fit against sheet metal walls, bottom and top of duct, and be securely fastened.
 - d. Where concealed ceiling damper regulators are installed, provide a cover plate.
 - 4. Install grilles, registers, and diffusers.

B. AIR TURNS

- 1. Permanently installed, consisting of curved metal blades or vanes arranged to permit air to make abrupt turn without appreciable turbulence, in elbows of supply and above ground return ductwork.
- 2. Air turns shall be quiet and free from vibration when system is in operation.

END OF SECTION 23 30 00

SECTION 23 70 00 - AIR CONDITIONING FOR HVAC

I. GENERAL

A. DESCRIPTION

1. The Air Conditioning System, in general, shall be for the entire building providing cooling and dehumidification in summer and heating in winter. A constant amount of fresh air shall be taken into the system and all air shall be filtered.
2. The General Contractor (Prime Contractor) who has the contracts with the Owner shall be responsible for installing the mechanical systems using qualified subcontractors and/or employees. Any incorrect or improper work shall be corrected by the General Contractor.

B. STANDARDS

1. All air conditioning equipment shall comply with the requirements of applicable ARI standards and shall be tested, rated, labeled, and listed accordingly.

C. SPACE REQUIREMENTS

1. General Contractor and Mechanical Contractor shall refer to architectural, structural and electrical drawings and install all equipment, piping, etc. to meet building and space requirements. No equipment shall be bid on or submitted for approval if it will not fit into the space provided or coordinate with other trades involved on the project.

D. COMPRESSOR WARRANTIES

1. On all system DX equipment 6 tons and larger, the manufacturer shall provide a full 5 year labor and material warranty for any and all compressor failures during the warranty period.
2. This warranty shall not include any equipment maintenance; all equipment maintenance is the responsibility of the Owner. The manufacturer shall have full access to the units during the construction period.
3. If a longer warranty period is required elsewhere in these specs, the longer warranty period shall apply.

II. MATERIALS

A. PIPING

1. All piping shall be of materials as hereinbefore specified.

B. HEAT PUMP - OUTDOOR SECTION

1. Furnish and install heat pump - outdoor section where shown and with capacities scheduled on plans. Unit shall be completely factory assembled and tested by the equipment manufacturer.
2. Condenser coil shall be of nonferrous construction with aluminum plated fins mechanically bonded to seamless copper tubes.
3. Condenser fan shall be propeller type, direct driven. Motor shall have inherent protection and be of the permanently lubricated type, resiliently mounted. Fans shall have safety guards.
4. Units shall be designed for operation down to 0 degrees Fahrenheit outdoor temperature.
5. Compressor shall be of sealed hermetic design with external spring isolators. Compressors shall have five year replacement warranty by the unit manufacturer (not the compressor manufacturer). Warranty period shall start when project is accepted by the Owner.
6. All controls shall be factory wired and shall consist of high and low pressurestats, compressor and condenser fan overload devices, etc., as required by manufacturer for complete unit protection.
7. Casing shall be fully weatherproof for outdoor installation and shall be bonderized steel with baked enamel finish. Panels shall be removable to provide access for servicing.
8. Unit shall be Trane, Lennox, JCI or Carrier.

C. HEAT PUMP - INDOOR SECTION

1. Furnish and install heat pump - indoor section of size and type as scheduled on the drawings. Units shall be York, Lennox or Carrier.
2. Units shall be complete with fan, motor, drive, direct expansion cooling coil, grease fittings, drain pan, etc., and shall have capacities scheduled on plans. All units shall be factory insulated on the interior with not less than 3/4 pound density neoprene coated fiberglass cemented in place with waterproof adhesive.
3. Each unit shall be mounted on a suitable base to allow return air and designed for continuous operation at the maximum rated static pressure. Fan capacities shall be rated with the fans in the units, and horsepowers specified shall include all losses.
4. Casings shall be suitable for operation at the pressures specified and constructed of bonderized steel.

5. Cooling coils shall be of the nonferrous tube and nonferrous fin type and shall be tested at 400 psi air pressure. Cooling coil face velocity shall not exceed that guaranteed by manufacturer for no moisture carry-over.
6. Electric strip heaters shall be as hereinafter specified and shall be mounted inside unit housing. Coordinate electric service to heaters and blower with Electrical Contractor.
7. Filter shall be 1 inch thick throw-away mounted in factory filter rack in unit.

D. AUXILIARY ELECTRIC STRIP HEATERS

1. Provide UL and CSA approved electric heat modules for installation directly on fan discharge. Electric heaters shall be furnished in capacities as scheduled with one or two stage control, single-point electric power connection and terminal strip connections.
2. Electric heater elements shall be constructed of heavy duty nickel chromium elements internally wye connected on 480/600 volt, three-phase and delta connected on 208/240 volt, three-phase.
3. All terminal studs, nuts and washers shall be stainless steel, insulated with phenolic terminal bushings. Terminals shall be machine crimped to coils and heater shall be tested at 2000 volts before shipment. All voltages and phases shall be as scheduled.
4. Heaters shall be provided with built-in contactors with one internally fused terminal block with separate contactors for each stage of heating. Heater shall be internally wired at factory to receive one electrical source of power for air unit-heater combination.
5. Each 208/240 volt heater shall have pilot duty with secondary backup fuse links for automatic reset of high limit controls. Each 480/600 volt heater shall have automatic line break high limit controls.
6. Control circuit transformer shall be built into heater terminal box and sized to carry full contactor holding coil load. Heaters shall be listed by UL.
7. Heater shall be equipped with built-in pressure type air flow switch.
8. Heater shall be installed inside unit housing as recommended by equipment manufacturer.

III. EXECUTION

A. INSTALLATION

1. Install air conditioning systems in accordance with Section 23 05 00.

2. Mount equipment on pads, complete with piping system, install air unit complete with air distribution system, and provide for power connection.
3. Complete structural, mechanical, and electrical connections in accordance with manufacturer's installation instructions.

B. TESTING

1. Refrigerant lines shall be tested under 200 psi carbon dioxide pressure for five hours using soap suds at joints to test for leaks. Evacuate system and charge with refrigerant.
2. All line testing shall be witnessed by the Test and Balance Agency (TAB). TAB Agency shall record results and include in final TAB report.

END OF SECTION 23 70 00

SECTION 26 01 00 – ELECTRICAL GENERAL CONDITIONS

PART 1 - GENERAL

1.1 DESCRIPTION

- A. The General Conditions and all pertinent sections are part of this specification, and the Contractor shall consult them in detail in instruction pertaining to this work. He shall consult all other sections of the specifications to determine if he is required to perform any work related to that particular section.

1.2 SCOPE OF WORK

- A. The work contemplated under this specification comprises the furnishing of all labor and material required and necessary for the complete installation of electrical wiring in conduit for lighting control and power from existing panelboards to each ultimate outlet hereinafter specified and/or shown on the accompanying drawings. Said work shall be done in accordance with the latest edition of the National Electrical Code, NFPA codes and all local codes and ordinances. The specifications are intended to describe a complete workable system and bidders shall report any discrepancies or omissions preventing such workability prior to the time of the bids are submitted.
- B. The work covered by this specification shall be shown on plans and called for herein, and shall be comprised generally of the following:
 - 1. Furnish and install all conduit and wiring raceways, conductors, disconnects, panels, etc.
 - 2. Furnish and install feeders and branch circuits.
 - 3. Furnish and install service to all mechanical devices.
 - 4. Furnish and install light fixtures, power outlets, and all other electrical devices shown on plans.
- C. All equipment installed by this contractor shall be installed in strict accordance with instructions of the manufacturer.
- D. He shall install his work to meet existing conditions as found at the building site.
- E. The Electrical Contractor shall refer to the Architectural and Structural details for information in regard to the Architectural details. His work shall be done in strict accordance with local and state ordinances governing this class of work.

1.3 REJECTED WORK AND MATERIALS

- A. Should contractor introduce any materials different from those called for and described in specifications are shown on plans, it must on notification from the engineers, be immediately removed from building or premises.

1.4 SHOP DRAWINGS

- A. Before proceeding with work and/or within thirty (30) days award of the General Contract for this work, the Electrical Contractor shall furnish to the Architect/Engineer, complete shop and working drawings of such apparatus, equipment, controls insulation, etc. to be provide in this

project. These drawings shall give dimensions, weights, mounting data, performance curves, and other pertinent information. Shop drawings to be submitted as listed below.

1. Panels/Panelboards/Switchboards.
2. Disconnects.
3. Lighting Fixtures.
4. Conduit Fittings.
5. Electrical Devices.

- B. The contractor may be required to submit shop drawings on any other material he supplies in construction of this project. These drawings shall be submitted at time requested by Architect/Engineer.

1.5 ADDITIONS AND CHANGES

- A. The accompanying drawings show approximate location of feeders, branch circuits, light and power circuits, etc. Complete and accurate details in regard to locations of outlets, apparatus, etc. from location shown shall be made before roughing-in and without additional cost to the owner.

1.6 STANDARDS AND WORKMANSHIP

- A. All material shall be new and listed by UL as conforming to its standards. Work shall be executed in a workmanship manner and present a neat, finished appearance when completed.

1.7 PRIOR APPROVAL AND DRAWINGS

- A. Whenever manufacturers or trade names are mentioned in these plans or specifications, the words "or approved equivalent" shall be assumed to follow whether or not so stated. Manufacturers or trade names are used to establish a standard of quality only and should not in any way be construed to infer a preference. Equivalent products which meet the Engineer's approval will be accepted, however these products must be submitted to the Engineer a minimum of ten (10) days prior to bid date. Submission shall be included manufacturer's name, model number, rating table and construction features. Upon receipt and checking of this submittal, the Architect will issue an addendum listing items which are approved as equivalent to those specified. The Contractor shall base his bid solely on the items specified or included in the "Prior Approval Addendum" as no other items will be acceptable. Prior approval of a particular piece of equipment does not mean automatic final acceptance and will not relieve the Contractor of the responsibility of assuring himself that this equipment is in complete accord with plans and specifications and will fit into the space provided. Submit shop drawings on all items of equipment for approval as hereinafter specified. The Engineer's approval of shop drawings shall not relieve the Contractor from the responsibility of incorrectly figured dimensions or any other error that may be contained in these drawings. The omissions from the shop drawings, or

specifications, even though approved by the Engineer, shall not relieve this Contractor from furnishing and erecting same. **Prior Approvals submitted electronically will not be accepted.**

1.8 GAURANTEE

- A. The Contractor for this work shall be required to keep the work installed by him in repair and perfect working order for one (1) year from date of completion and final acceptance; said guarantee shall be based on defective materials and substandard workmanship. Contractor shall furnish, free of cost to owner, all materials and labor necessary to comply with this guarantee.

1.9 LAWS, PERMITS AND INSPECTIONS

- A. This contractor shall at his own cost obtain all necessary permits, pay all legal feed and charges and comply with all building and safety laws, ordinances and regulations relating to the building and the public health and safety, including NEC, NFPA, IBC, AND OSHA.
- B. Pay any and all fees required by local electric utility company to obtain electrical services outlined.

1.10 TESTS

- A. After installation is complete and at such time as the Engineers may direct, Contractor shall conduct an operating test for approval. Equipment shall be demonstrated to operate in accordance with requirements of this specification. The test shall be performed in the presence of Engineers. Contractor shall furnish all instruments and personnel required for the test.

1.11 CUTTING AND PATHNG

- A. Contractor shall do all cutting and patching where necessary at his own expense with approval of the Engineers as to cutting of any structural beams or joists, but all patching shall be done by crafts whose work is involved. After initial surfacing has been done, all further cutting, patching, and painting shall be done at this contractor's expense.

1.12 SAFETY PRECUATIONS

- A. Contractor shall furnish and place proper guards for prevention of accidents. He shall provide and maintain any other necessary construction required to secure safety of life or property, including maintenance of sufficient lights during all night hours to secure such protection.
- B. Temporary electrical services shall be provided by electrical contractor during construction and shall be maintained in perfect condition. Frayed, loose or opened connections shall not be used for temporary services. The Electrical Contractor shall use only equipment in first class working conditions for construction services. Contractor shall not use electrical services at existing area for construction unless otherwise authorized by owner.

1.13 SUPERVISION

- A. Contractor shall personally, or through an authorized and competent representative, constantly supervise the work done from beginning to completion and final acceptance. To the best of his

ability, he shall keep the same foreman and workmen throughout the project duration. During the progress of work, it shall be subject to inspection by the representatives of the Engineers, and at these times, the contractor shall furnish the required information.

1.14 INSERTS AND OPENINGS.

- A. Contractor shall furnish and install all inserts and hangers required to support conduit, cables, wireways, disconnect switches, etc.

1.15 OPENINGS THROUGH WALLS AND FLOORS

- A. Provide all slots, sleeved holes, and other openings necessary through walls and floors, and through any other parts of the structure. Where conduits pass through walls which are intended as rated fire walls, leave-outs, penetrations, or sleeves shall be sealed so as not to interfere with the rating of the wall.

1.16 BACKFILLING

- A. Contractor shall be responsible to backfill any trenches for electrical runs under the building, paving, or any area of the site by backfilling the bottom of the trench-up to the top of the conduit with sand, then placing compact fill in 6" layers using power tamping equipment.

1.17 RECORD DRAWINGS

- A. The Contractor shall be provided with a set of prints of the original bidding documents by the Architect. The Contractor Shall then have a set of sepia (reproducible plans) made.
- B. If the Contractor elects to vary from the contract documents and secures approval from the Architect for any phase of work, he shall record in a neat and readable manner, ALL such variances on the print in red. These changes shall be then transferred to the permanent set (sepia) at the completion of the job. Both the sepia and the original print shall be returned to the Engineer for documentation.
- C. All deviations from sizes, locations and from all other features of the installations shown in the Contract Documents shall be recorded.
- D. In addition, it shall be possible using these drawings to correctly and easily locate, identify and establish sizes of all piping, directions, and the like, as well as other features of work which will be concealed underground and/or in the finished building. Locations of underground work shall be established by dimensions to columns, lines, or walls, locating all turns, etc., and by properly referenced centerline.
- E. For work concealed in the building, sufficient information shall be given so it can be located with reasonable accuracy and ease. In some cases, this may be dimensions. In others, it may be sufficient to illustrate the work on the drawings in relation to the spaces in the building near which it was actually installed. Architect's/Engineer's decision in this matter will be final.
- F. The following requirement apply to all "record" drawings:
 - 1. The shall be maintained at the contractor's expense.
 - 2. All such drawing shall be done carefully and neatly and, in a form, approved by the Engineer.

3. Additional drawings shall be provided as necessary for clarification.
4. They shall be kept up-to-date during the entire course of the work and shall be available upon request for examination by Engineer and when necessary, to establish clearances for other parts of the work.
5. "Record" drawings shall be returned to the Architect/Engineer upon completion of the work and are subject to approval of the Engineer.
6. The Contractor shall refer to the Architectural section under "RECORD DRAWINGS" for further requirement and procedures.

END OF SECTION 26 01 00

SECTION 26 05 19 - CONDUCTORS AND CABLES

PART 1 - GENERAL

1.1 SUMMARY

- A. This Section includes building wires and cables and associated connectors, splices, and terminations for wiring systems rated 600 V and less.

1.2 SUBMITTALS

- A. Product Data: For each type of product indicated.

1.3 QUALITY ASSURANCE

- A. Electrical Components, Devices, and Accessories: Listed and labeled as defined in NFPA 70, Article 100, by a testing agency acceptable to authorities having jurisdiction, and marked for intended use.
- B. Comply with NFPA 70.

PART 2 - PRODUCTS

2.1 MANUFACTURERS

- A. In other Part 2 articles where paragraph titles below introduce lists, the following requirements apply for product selection.
 - 1. Manufacturers: Subject to compliance with requirements, provided products by the manufacturer specified.

2.2 CONDUCTORS AND CABLES

- A. Manufacturers:
 - 1. American Insulated wire Corp.: a Leviton company.
 - 2. General Cable Corporation.
 - 3. Southwire Company.
 - 4. AFC Cables
 - 5. Kaf Tech Cables
 - 6. Burndy Corp.
- B. Refer to Part 3 "Conductor and Insulation Applications" Article for insulation type, cable construction, and ratings.

- C. Conductor Material: Copper, solid conductor for No. 10 AWG and smaller, stranded for no. 8 AWG and larger.
- D. Conductor Insulation Types: Type THHN-THWN complying with NEMA WC 5.

2.3 CONNECTORS AND SPLICES

- A. Description: Factory-fabricated connectors and splices of size, ampacity rating, material, type, and class for application and service indicated.

PART 3 - EXECUTION

3.1 CONDUCTOR AND INSULATION APPLICATIONS

- A. Service Entrance: Type XHHW, single conductors in raceway.
- B. Exposed Feeders: Type THHN-THWN, single conductors in raceway.
- C. Feeders Concealed in Ceilings, Walls, and Partitions: Type THHN-THWN, single conductors in raceway.
- D. Feeders below Slabs-on-Grade, and in Crawlspace: Type THHN-THWN, single conductors in raceway.
- E. Exposed Branch Circuits, including in Crawlspace: Type THHN-THWN, single conductors in raceway.
- F. Branch Circuits Concealed in Ceilings, Walls, and Partitions: Type THHN-THWN, single conductors in raceway.
- G. Branch Circuits below Slabs-on-Grade: Type THHN-THWN, single conductors in raceway.
- H. Cord Drops and Portable Appliance Connections: Type SO, hard service cord.
- I. Fire Alarm Circuits: Power-limited, fire-protective, signaling circuit cable in raceway.
- J. Class 1 Control Circuits: Type THHN-THWN, in raceway.
- K. Class 2 Control Circuits: Type THHN-THWN, in raceway.

3.2 INSTALLATION

- A. Conceal cables in finished walls, ceilings, and floors, unless otherwise indicated.
- B. Use manufacturer-approved pulling compound or lubricant where necessary; compound used must not deteriorate conductor or insulation. Do not exceed manufacturer's recommended maximum pulling tensions and sidewall pressure values.

- C. Use pulling means, including fish tape, cable, rope, and basket-weave wire/cable grips, that will not damage cables or raceway.
- D. Install exposed cables parallel and perpendicular to surfaces of exposed structural members, and follow surface contours where possible.
- E. Support cables according to Division 16 Section "Basic Electrical Materials and Methods."
- F. Seal around cables penetrating fire-rated elements according to Specification Section "Through-Penetration Firestop Systems."
- G. Identify and color-code conductors and cables according to Division 16 Section "Electrical Identification."
- H. Make splices and taps that are compatible with conductor material and that possess equivalent or better mechanical strength and insulation ratings than unspliced conductors.
- I. Wiring at Outlets: Install conductor at each outlet, with at least 8 inches of slack.

3.3 CONNECTIONS

- A. Tighten electrical connectors and terminals according to manufacturer's published torque-tightening values.
- B. Make splices and taps that are compatible with conductor material and that possess equivalent or better mechanical strength and insulation ratings than unspliced conductors.
- C. Wiring at Outlets: Install conductor at each outlet, with at least 12 inches of slack.

3.4 FIELD QUALITY CONTROL

- A. Testing: Perform the following field quality-control testing:
 - 1. After installing conductors and cables and before electrical circuitry has been energized, test for compliance with requirements.

END OF SECTION 26 05 19

SECTION 26 05 26 - GROUNDING AND BONDING

PART 1 - GENERAL

1.1 RELATED DOCUMENTS

- A. Drawings and general provisions of the Contract, including General and Supplementary Conditions and Division 1 Specification Sections, apply to this Section.

1.2 SUMMARY

- A. This Section includes grounding of electrical systems and equipment. Grounding requirements specified in this Section may be supplemented by special requirements of systems described in other Sections.

1.3 SUBMITTALS

- A. Product Data: For each type of product indicated.
- B. Product Data: For the following:
 - 1. Ground rods.
- C. Qualification Data: For firms and persons specified in "Quality Assurance" Article.
- D. Field Test Reports: Submit written test reports to include the following.
 - 1. Test procedures used.
 - 2. Test results that comply with requirements.
 - 3. Results of failed test and corrective action taken to achieve test results that comply with requirements.

1.4 QUALITY ASSURANCE

- A. Testing Agency Qualifications: Testing agency as defined by OSHA in 29 CFR 1910.7 or a member company of the International Electrical Testing Association and that is acceptable to authorities having jurisdiction.
 - 1. Testing Agency's Field Supervisor: Person currently certified by the International Electrical Testing Association to supervise on-site specified in Part 3.
- B. Electrical Components, Devices, and Accessories: Listed and labeled as defined in NFPA 70, Article 100, by a testing agency acceptable to authorities having jurisdiction, and marked for intended use.
 - 1. Comply with UL 467.
- C. Comply with NFPA 70: for overhead-line construction and medium-voltage underground construction, comply with IEEE C2.

- D. Comply with NFPA 780 and UL 96 when interconnection with lighting protection systems.

PART 2 - PRODUCTS

2.1 MANUFACTURES

- A. Manufactures: Subject to compliance with requirements, provide products by on of the following:
 - 1. Grounding Conductors, Cables, Connectors, and Rods.
 - a. Apache Grounding/Erico Inc.
 - b. Boggs, Inc.
 - c. Chance/Hubell
 - d. Copperweld Corp.
 - e. Dossert Corp.
 - f. Erico Inc.: Electrical Group.
 - g. Framatome Connectors/Burndy Electrical.
 - h. Galvan Industries, Inc.
 - i. Ideal Industries, Inc.
 - j. ILSCO.
 - k. Kearney/Cooper Power Systems.
 - l. Korn's: C.C. Korn's Co.: Division of Robroy Industries.
 - m. Lyncole XIT Grounding.
 - n. O-Z/Gedney Co.: a business of the EGS Electrical Group.
 - o. Raco, Inc.; division of Hubell.
 - p. Salisbury; W.H. Salisbury & Co.
 - q. Superior Grounding Systems, Inc.
 - r. Thomas & Betts, Electrical.

2.2 GROUNDING CONDUCTORS

- A. For insulated conductors, comply with Division 16 Section "Conductors and Cables."
- B. Material: Copper.
- C. Equipment Grounding Conductors: Insulated with green-colored insulation.
- D. Isolated Ground Conductors: Insulated with green-colored insulation with yellow stripe. On feeders with isolated ground, use colored tape, alternating bands of green and yellow tape to provide a minimum of three bands of green and two bands of yellow.
- E. Grounding Electrode Conductors: Stranded cable.
- F. Underground Conductors: Bare, tinned, stranded, unless otherwise indicated.
- G. Bare Copper conductors: Comply with the following:
 - 1. Solid Conductors: ASTM B3.
 - 2. Assembly of Stranded Conductors: ASTM B8.
 - 3. Tinned Conductors: ASTM B33.

H. Copper Bonding Conductors: As follows:

1. Bonding Cable: 28 kcmil, 14 strands of No. 17 AWG copper conductor, 1/4 inch in diameter.
2. Bonding Conductor: No. 4 or No. 6 AWG, stranded copper conductor.
3. Bonding Jumper: Bare (uninsulated) copper tape, braided bare (uninsulated) copper conductors, terminated with copper ferrules; 1-5/8 inches wide and 1/16 inch thick.
4. Tinned Bonding Jumper: Tinned-copper tape, braided copper conductors, terminated with copper ferrules; 1-5/8 inches wide and 1/16 inch thick.

I. Grounding Bus: Bare (uninsulated), annealed copper bars of rectangular cross section, with insulators.

2.3 CONNECTOR PRODUCTS

- A. Listed for use for specific types, sizes, and combinations of conductors and connected items.
- B. Bolted Connectors: Bolted-pressure-type connectors, or compression type.
- C. Welded Connectors: Exothermic-welded type, in kit form, and selected per manufacturer's written instructions.

2.4 GROUNDING ELECTRODES

- A. Ground Rods: Sectional type; copper-clad steel.
 1. Size: 3/4 by 120 inches in diameter.

PART 3 - EXECUTION

3.1 APPLICATION

- A. Use only copper conductors for both insulated and bare (uninsulated) grounding conductors in direct contact with earth, crushed stone, and similar materials.
- B. In raceways, use insulated equipment grounding conductors.
- C. Exothermic-Welded Connections: Use for connections to structural steel and for underground connections, except those at test wells.
- D. Equipment Grounding Conductor Terminations: Use bolted pressure clamps.
- E. Ground Rod Clamps at Test Wells: Use bolted pressure clamps with at least two bolts.
- F. Grounding Bus: Install in electrical and telephone equipment rooms, in rooms housing service equipment, and elsewhere as indicated.

1. Use insulated spacer; space 1 inch from wall and support from wall 6 inches above finished floor, unless otherwise indicated.
- G. Underground Grounding Conductors: Use copper conductor, No. 2/0 AWG minimum. Bury at least 24 inches below grade.

3.2 EQUIPMENT GROUNDING CONDUCTORS

- A. Comply with NFPA 70, Article 250, for types, sizes, and quantities of equipment grounding conductors, unless specific types, larger sizes, or more conductors than required by NFPA 70 are indicated.
- B. Install equipment grounding conductors in all feeders and circuits.
- C. Install insulated equipment grounding conductor with circuit conductors for the following items, in addition to those required by NEC:
1. Feeders and branch circuits.
 2. Lighting circuits.
 3. Receptacle circuits.
 4. Single-phase motor and appliance branch circuits.
 5. Three-phase motor and appliance branch circuits.
 6. Flexible raceway runs.
- D. Computer Outlet Circuits: Install insulated equipment grounding conductor in branch-circuit runs from computer-area power panels or power-distribution units.
- E. Isolated Grounding Receptacle Circuits: Install an insulated equipment grounding conductor connect to the receptacle grounding terminal. Isolate grounding conductor from raceway and from panel board grounding terminal. Terminate at equipment grounding conductor terminal of the applicable derived system or service, unless otherwise indicated.
- F. Isolated Equipment Enclosure Circuits: For designated equipment supplied by a branch circuit or feeder, isolate equipment enclosure from supply raceway with a nonmetallic raceway fitting listed for the purpose. Install fitting where raceway enters enclosure and install a separate equipment grounding conductor. Isolate equipment grounding conductor from raceway and from panelboard grounding terminals. Terminate at equipment grounding conductor terminal of the applicable derived system or service, unless otherwise indicated.
- G. Nonmetallic Raceways: Install an equipment grounding conductor in nonmetallic raceways unless they are designated for telephone or data cables.
- H. Signal and Communication Systems: for telephone, alarm, voice and data, and other communication systems, provide No. 6 AWG minimum uninsulated grounding conductor in raceway from grounding electrode system to each service location, terminal cabinet, wiring closet, and central equipment location.
1. Service and Central Equipment Locations and Wiring Closets: Terminate grounding conductor on a 12 slot copper grounding bus.
 2. Terminal Cabinets: Terminate grounding conductor on cabinet grounding terminal.

- I. Metal Poles Supporting Outdoor Lighting Fixtures: Provide a grounding electrode in addition to installing a separate equipment grounding conductor with supply branch-circuit conductors.

3.3 INSTALLATION

A. Ground Rods:

1. Drive ground rods until tops are 2 inches below finished floor or final grade, unless otherwise indicated.
2. Interconnect ground rods with grounding electrode conductors. Use exothermic welds, except at test wells and as otherwise indicated. Make connections without exposing steel or damaging copper coating.

- #### B. Grounding Conductors: Route along shortest and straightest paths possible, unless otherwise indicated. Avoid obstructing access or placing conductors where they may be subjected to strain, impact, or damage.

- #### C. Bonding Straps and Jumpers: Install so vibration by equipment mounted on vibration isolation hangers and supports is not transmitted to rigidly mounted equipment. Use exothermic-welded connectors for outdoor locations, unless a disconnect-type connection is required; then, use a bolted clamp. Bond straps directly to the basic structure taking care not to penetrate any adjacent parts. Install straps only in locations accessible for maintenance.

- #### D. Metal Water Service Pipe: Provide insulated copper grounding conductors, in conduit, from building's main service equipment, or grounding bus, to main metal water service entrances to building. Connect grounding conductors to main metal water service pipes by grounding clamp connectors. Where a dielectric main water fitting is installed, connect grounding conductor to street side of fitting. Bond metal grounding conductor conduit or sleeve to conductor at each end.

- #### E. Water Meter Piping: Use braided-type bonding jumpers to electrically bypass water meters. Connect to pipe with grounding clamp connectors.

- #### F. Bond interior metal piping systems and metal air ducts to equipment grounding conductors of associated pumps, fans, blowers, electric heaters, and air cleaners. Use braided-type bonding straps.

- #### G. Install one test well for each service at the ground rod electrically closest to the service entrance. Set top of well flush with finished grade or floor.

- #### H. Proposed location by contractor for Engineer review in counterpoise shop drawings.

3.4 CONNECTIONS

- #### A. General: Make connections so galvanic action or electrolysis possibility is minimized. Select connectors, connection hardware, conductors, and connection methods so metals in direct contact will be galvanically compatible.

1. Use electroplated or hot-tin-coated materials to ensure high conductivity and to make contact points closer to order of galvanic series.
 2. Make connections with clean, bare (clean) metal at points of contact.
 3. Make aluminum-to-steel connections with stainless-steel separators and mechanical clamps.
 4. Make aluminum-to-galvanized steel connections with tin-plated copper jumpers and mechanical clamps.
 5. Coat and seal connections having dissimilar metals with inert material to prevent future penetration of moisture to contact surfaces.
- B. Exothermic-Welded Connections: Comply with manufacturer's written instructions. Welds that are puffed up or that show convex surfaces indicating improper cleaning are not acceptable.
- C. Equipment Grounding Conductor Terminations: For No. 8 AWG and larger, use pressure-type grounding lugs. No. 10 AWG and smaller grounding conductors may be terminated with winged pressure-type connectors.
- D. Noncontact Metal Raceway Terminations: If metallic raceways terminate at metal housings without mechanical and electrical connection to housing, terminate each conduit with a grounding bushing. Connect grounding bushings with a bare (uninsulated) grounding conductor to grounding bus or terminal in housing. Bond electrically noncontinuous conduits at entrances and exits with grounding bushings and bare (uninsulated) grounding conductors, unless otherwise indicated.
- E. Connections at Test Wells: Use compression-type connectors on conductors and make bolted-and clamped-type connections between conductors and ground rods.
- F. Tighten screws and bolts for grounding and bonding connectors and terminals according to manufacturer's published torque-tightening values.
- G. Compression-Type Connections: Use hydraulic compression tools to provide correct circumferential pressure for compression connectors. Use tools and dies recommended by connector manufacturer. Provide embossing die code or other standard method to make a visible indication that a connector has been adequately compressed on grounding conductor.
- H. Moisture Protection: If insulated grounding conductors are connected to ground rods or grounding buses, insulate entire area of connection and seal against moisture penetration of insulation and cable.

3.5 FIELD QUALITY CONTROL

- A. Testing: Perform the following field quality-control testing:
1. After installing grounding system but before permanent electrical circuitry has been energized, test for compliance with requirements.
 2. Test completed grounding system at each location where a maximum ground-resistance level is specified, at service disconnect enclosure grounding terminal, and at ground test wells. Measure ground resistance not less than two full days after the last trace of precipitation, and without the soil being moistened by any means other than natural drainage or seepage and without chemical treatment or other artificial means of reducing

- natural ground resistance. Perform tests, by the fall-of-potential method according to IEEE 81.
3. Provide drawings locating each ground rod and ground rod assembly and other grounding electrodes, identify each by letter in alphabetical order, and key to the record of tests and observations. Include the number of rods driven and their depth at each location and include observations of weather and other phenomena that may affect test results. Describe measures taken to improve test results.
 - a. Equipment Rated 500 kVA and Less: 10 ohms.
 - b. Equipment Rated 500 to 1000 kVA: 5 ohms.
 - c. Equipment Rated More Than 1000 kVA: 3 ohms.
 - d. Substations and Pad-Mounted Switching Equipment: 5 ohms.
 - e. Manhole Grounds: 10 ohms.
 4. Excessive Ground Resistance: If resistance to ground exceeds specified values, notify Architect promptly and include recommendations to reduce ground resistance.

3.6 GRADING AND PLANTING

- A. Restore surface features, including vegetation, at areas disturbed by Work of this Section. Reestablish original grades, unless otherwise indicated. If sod has been removed, replace it as soon as possible after backfilling is completed. Restore areas disturbed by trenching, storing of dirt, cable laying, and other activities to their original condition. Include application of topsoil, fertilizer, lime, seed, sod, sprig, and mulch. Comply with Division 2 Section "Landscaping." Maintain restored surfaces. Restore disturbed paving as indicated.

END OF SECTION 26 05 26

SECTION 16 05 33 - RACEWAYS AND BOXES

PART 1 - GENERAL

1.1 RELATED DOCUMENTS

- A. Drawings and general provisions of the Contract, including General and Supplementary Conditions and Division 1 Specification Sections, apply to this Section.

1.2 SUMMARY

- A. This Section includes raceways, fittings, boxes, enclosures, and cabinets for electrical wiring.
- B. Related Sections include the following:
 - 1. Specification Section "Through-Penetration Firestop Systems" for firestopping materials and installation at penetrations through walls, ceilings, and other fire-rated elements.
 - 2. Division 16 Section "Basic Electrical Materials and Methods" for supports, anchors, and identification products.
 - 3. Division 16 Section "Wiring Devices" for devices installed in boxes and for floor-box service fittings.

1.3 DEFINITIONS

- A. EMT: Electrical metallic tubing.
- B. ENT: Electrical nonmetallic tubing.
- C. FMC: Flexible metal conduit.
- D. IMC: Intermediate metal conduit.
- E. LFMC: Liquidtight flexible metal conduit.
- F. LFNC: Liquidtight flexible nonmetallic conduit.
- G. RNC: Rigid nonmetallic conduit.

1.4 SUBMITTALS

- A. Product Data: For surface raceways, wireways and fittings, floor boxes, hinged-cover enclosures, and cabinets.
- B. Shop Drawings: Show fabrication and installation details of components for raceways, fittings, boxes, enclosures, and cabinets.

- C. Coordination Drawings: Reflected ceiling plans drawn to scale and coordinating penetrations and ceiling-mounted items. Show the following:
 - 1. Ceiling suspension assembly members.
 - 2. Method of attaching hangers to building structure.
 - 3. Size and location if initial access modules for acoustical tile.
 - 4. Ceiling-mounted items including lighting fixtures, diffusers, grilles, speakers, sprinklers, access panels, and special moldings.

1.5 QUALITY ASSURANCE

- A. Electrical Components, Devices, and Accessories: Listed and labeled as defined in NFPA 70, Article 100, by a testing agency acceptable to authorities having jurisdiction, and marked for intended use.
- B. Comply with NFPA 70.

1.6 COORDINATION

- A. Coordinate layout and installation of raceways, boxes, enclosures, cabinets, and suspension system with other construction that penetrates ceilings or is supported by them, including light fixtures, HVAC equipment, fire-suppression system, and partition assemblies.

PART 2 - PRODUCTS

2.1 MANUFACTURERS

- A. In other Part 2 articles where subparagraph titles below introduce lists, the following requirements apply for product selection:
 - 1. Manufacturers: Subject to compliance with requirements, provide products by the manufacturers specified.

2.2 METAL CONDUIT AND TUBING

- A. Manufacturers:
 - 1. Grinnell Co./Tyco International; Allied Tube and Conduit Division.
 - 2. LTV Steel Tubular Products Company.
 - 3. O-Z Gedney; Unit of General Signal.
 - 4. Wheatland Tube Co.
- B. Rigid Steel Conduit: ANSI C80.1
- C. Aluminum Rigid Conduit: ANSI C80.5
- D. IMC: ANSI C80.6
- E. Plastic-Coated Steel Conduit and Fittings: NEMA RN 1.

- F. Plastic-Coated IMC and Fittings: NEMA RN1
- G. EMT and Fittings: ANSI C80.3
 - 1. Fittings: compression type.
- H. FMC: Zinc-coated steel.
- I. LFMC: Flexible steel conduit with PVC jacket.
- J. Fittings: NEMA FB 1; compatible with conduit and tubing materials.

2.3 NONMETALLIC CONDUIT AND TUBING

- A. Manufacturers:
 - 1. American International.
 - 2. Anamet Electrical, Inc.; Anaconda Metal Hose.
 - 3. Aruco Corp.
 - 4. Cantex Inc.
 - 5. Certaineed Corp.; Pipe & Plastics Group.
 - 6. Condux International.
 - 7. ElecSYS, Inc.
 - 8. Lamson & Sessions; Carlon Electrical Products.
 - 9. Manhattan/CDT/Cole-Flex.
 - 10. RACO; Division of Hubell, Inc.
 - 11. Thomas & Betts Corporation.
- B. ENT: NEMA TC 13.
- C. RNC: NEMA TC2, Schedule 40 and Schedule 80 PVC.
- D. ENT and RNC Fittings: NEMA TC3; match to conduit or tubing type and material.
- E. LFNC: UL 1660.

2.4 METAL WIREWAYS

- A. Manufacturers:
 - 1. Hoffman.
 - 2. Square D.
 - 3. Wiegman.
- B. Material and Construction: Sheet metal sized and shaped as indicated, NEMA 1 or 3R as required.
- C. Fittings and Accessories: Include couplings, offsets, elbows, expansion joints, adapters, hold-down straps, end caps, and other fittings to match and mate with wireways as required for complete system.

- D. Select features, unless otherwise indicated, as required to complete wiring system and to comply with NFPA 70.
- E. Wireway Covers: Hinged type.
- F. Finish: Manufacturer's standard enamel finish.

2.5 SURFACE RACEWAYS

- A. Manufacturers:
 - 1. Airey-Thompson Sentinel Lighting: Wiremold Company (The).
 - 2. Thomas & Betts Corporation.
 - 3. Walker Systems, Inc.; Wiremold Company (The).
 - 4. Wiremold Company (The); Electrical Sales Division.
- B. Surface Metal Raceways: Galvanized steel with snap-on covers. Finish with manufacturer's standard prime coating.
- C. Types, sizes, and channels as indicated and required for each application, with fittings that match and mate with raceways.

2.6 BOXES, ENCLOSURES, AND CABINETS

- A. Manufacturers:
 - 1. Cooper Crouse-Hinds; Div. of Cooper Industries, Inc
 - 2. Emerson/General Signal; Appleton Electric Company.
 - 3. Erickson Electrical Equipment Co.
 - 4. Hoffman.
 - 5. Hubbell Inc.; Killark Electric Manufacturing Co.
 - 6. O-Z/Gedney; Unit of General Signal.
 - 7. RACO; Division of Hubell, Inc.
 - 8. Robroy Industries, Inc; Enclosure Division.
 - 9. Scott Fetzer Co.; Adalete-PLM Division.
 - 10. Spring City Electrical Manufacturing Co.
 - 11. Thomas Betts Corporation.
 - 12. Walker Systems, Inc.; Wiremold Company (The).
 - 13. Woodhead, Daniel Company; Woodhead Industries, Inc. Subsidiary.
- B. Sheet Metal Outlet and Device Boxes: NEMA OS1.
- C. Cast-Metal Outlet and Device Boxes: NEMA FB1, type FD, with gasketed cover.
- D. Floor Boxes: Cast metal, fully adjustable, rectangular.
- E. Small Sheet Metal Pull and Junction Boxes:
- F. Cast-Metal Pull and Junction Boxes: cast aluminum with gasketed cover.
- G. Hinged-Cover Enclosures: Type 1, with continuous hinge cover and flush latch.

1. Metal Enclosures: Steel, finished inside and out with manufacturer's standard enamel.
- H. Cabinets: Type 1, galvanized steel box with removable interior panel and removable front, finished inside and out with manufacturer's standard enamel. Hinged door in front cover with flush latch and concealed hinge. Key latch to match panelboards. Include metal barriers to separate wiring of different systems and voltage and include accessory feet where required for freestanding equipment.

2.7 FACTORY FINISHES

- A. Finish: For raceway, enclosure, or cabinet components, provide manufacturer's standard prime-coat finish ready for field painting.

PART 3 - EXECUTION

3.1 RACEWAY APPLICATION

A. Outdoors:

1. Exposed: Rigid steel or IMC.
2. Concealed: Rigid steel or IMC.
3. Underground, Single Run: RNC.
4. Underground, Grouped: RNC.
5. Connection to Vibrating Equipment (Including Transformers and Hydraulic, Pneumatic, Electric Solenoid, or Motor-Driven Equipment): LFMC.
6. Boxes and Enclosures: NEMA 250Type 3R.

B. Indoors:

1. Exposed: EMT.
2. Concealed: EMT.
3. Connection to Vibrating Equipment (Including Transformers and Hydraulic, Pneumatic, Electric Solenoid, or Motor-Driven Equipment): FMC; except use LFMC in damp or wet locations.
4. Damp or Wet Locations: Rigid steel conduit.
5. Boxes and Enclosures: NEMA Type 1, except as follows:
 - a. Damp or Wet Locations: NEMA Type 4.

C. Minimum Raceway Size: 1/2-inch trade size above grade, 3/4" min. below grade.

D. Raceway Fittings: Compatible with raceways and suitable for use and location.

1. Intermediate Steel Conduit: Use threaded rigid steel conduit fittings, unless otherwise indicated.

E. Do not install aluminum conduits embedded in or in contact with concrete unless properly protected where routed through or in concrete.

3.2 INSTALLATION

- A. Keep raceways at least 6 inches away from parallel runs of flues and steam or hot-water pipes. Install horizontal raceway runs above water and steam piping.
- B. Complete raceway installation before starting conductor installation.
- C. Support raceways as specified in Division 16 Section "Basic Electrical Materials and Methods."
- D. Install temporary closures to prevent foreign matter from entering raceways.
- E. Protect stub-ups from damage where conduits rise through floor slabs. Arrange so curved portions of bends are not visible above the finished slab.
- F. Make bends and offsets so ID is not reduced. Keep legs of bends in the same plane and keep straight legs of offsets parallel, unless otherwise indicated.
- G. Conceal conduit and EMT within finished walls, ceilings, and floors, unless otherwise indicated.
 - 1. Install concealed raceways with a minimum of bends in the shortest practical distance, considering type of building construction and obstructions, unless otherwise indicated.
- H. Raceways shall not be embedded in concrete slabs.
- I. Install exposed raceways parallel or at right angles to nearby surfaces or structural members and follow surface contours as much as possible.
 - 1. Run parallel or banked raceways together on common supports.
 - 2. Make parallel bends in parallel or banked runs. Use factory elbows only where elbows can be installed parallel; otherwise, provide field bends for parallel raceways.
- J. Join raceways with fittings designed and approved for that purpose and make joints tight.
 - 1. Use insulating bushings to protect conductors.
- K. Terminations:
 - 1. Where raceways are terminated with locknuts and bushings, align raceways to enter squarely and install locknuts with dished part against box. Use two locknuts, one inside and one outside box.
 - 2. Where raceways are terminated with threaded hubs, screw raceways or fittings tightly into hub so end bears against wire protection shoulder. Where chase nipples are used, align raceways so coupling is square to box; tighten chase nipple so no threads are exposed.
- L. Install pull wires in empty raceways. Use polypropylene or monofilament plastic line with not less than 200-lb tensile strength. Leave at least 12 inches of slack at each end of pull wire.
- M. Telephone and Signal System Raceways, 2-Inch Trade Size and Smaller: In addition to above requirements, install raceways in maximum lengths of 150 feet and with a maximum of two 90-

degree bends or equivalent. Separate lengths with pull or junction boxes where necessary to comply with these requirements.

- N. Install raceway sealing fittings at suitable, approved, and accessible locations and fill them with UL-listed sealing compound. For concealed raceways, install each fitting in a flush steel box with a blank cover plate having a finish similar to that of adjacent plates or surfaces. Install raceway sealing fittings at the following points:
 - 1. Where conduits pass from warm to cold locations, such as boundaries of refrigerated spaces.
 - 2. Where otherwise required by NFPA 70.
- O. Stub-up Connections: Extend conduits through concrete floor for connection to freestanding equipment. Install with an adjustable top or coupling threaded inside for plugs set flush with finished floor. Extend conductors to equipment with rigid steel conduit; FMC may be used 6 inches above the floor. Install screwdriver-operated, threaded plugs flush with floor for future equipment connections.
- P. Flexible Connections: Use maximum of 72 inches of flexible conduit for recessed and semi-recessed lighting fixtures; for equipment subject to vibration, noise transmission, or movement; and for all motors. Use LFMC in damp or wet locations. Install separate ground conductor across flexible connections.
- Q. Surface Raceways: Install a separate, green, ground conductor in raceways from junction box supplying raceways to receptacle or fixture ground terminals.
- R. Set floor boxes level and flush with finished floor surface.
- S. Set floor boxes level. Trim after installation to fit flush with finished floor surface.

3.3 PROTECTION

- A. Provide final protection and maintain conditions that ensure coatings, finishes, and cabinets are without damage or deterioration at time of Substantial Completion.
 - 1. Repair damage to galvanized finishes with zinc-rich paint recommended by manufacturer.
 - 2. Repair damage to PVC or paint finishes with matching touchup coating recommended by manufacturer.

3.4 CLEANING

- A. After completing installation of exposed, factory-finished raceways and boxes, inspect exposed finishes and repair damaged finishes.

END OF SECTION 26 05 33

SECTION 26 05 53 - ELECTRICAL IDENTIFICATION

PART 1 - GENERAL

1.1 RELATED DOCUMENTS

- A. Drawings and general provisions of the Contract, including General and Supplementary Conditions and Division 1 Specification Sections, apply to this Section.

1.2 SUMMARY

- A. This Section includes electrical identification materials and devices required to comply with, ANSI C2, NFPA 70, OSHA, and authorities having jurisdiction.

1.3 SUBMITTALS

- A. Product Data: For each electrical identification product indicated.
- B. Schedule of Nomenclature: An index of electrical equipment and system components used in identification signs and labels.

1.4 QUALITY ASSURANCE

- A. Comply with ANSI C2.
- B. Comply with NFPA 70.
- C. Comply with ANSI A13.1, and NFPA 70 for color-coding.

PART 2 - PRODUCTS

2.1 RACEWAY AND CABLE LABELS

- A. Comply with NFPA 70, for minimum size of letters for legend and for minimum length of color field for each raceway and cable size.
 - 1. Color: Black letters on orange field.
 - 2. Legend: Indicates voltage and service.
- B. Adhesive Labels: Preprinted, flexible, self-adhesive vinyl with legend overlaminated with a clear, weather- and chemical-resistant coating.
- C. Underground-Line Warning Tape: Permanent, bright-colored, continuous-printed, vinyl tape.

1. Not less than 6 inches wide by 4 mils thick.
 2. Compounded for permanent direct-burial service.
 3. Embedded continuous metallic strip or core.
 4. Printed legend indicating type of underground line.
- D. Tape Markers: Vinyl or vinyl-cloth, self-adhesive, wraparound type with preprinted numbers and letters.
- E. Aluminum, Wraparound Marker Bands: Bands cut from 0.014-inch thick aluminum sheet, with stamped or embossed legend and fitted with slots or ears for permanently securing around wire or cable jacket or around groups of conductors.
- F. Plasticized Card-stock Tags: Vinyl cloth with preprinted and field-printed legends. Orange background, unless otherwise indicated, with eyelet for fastener.

2.2 NAMEPLATES AND SIGNS

- A. Engraved Plastic Nameplates and Signs: Engraving stock, melamine plastic laminate, minimum 1/16 inch thick for signs up to 20 sq. in. and 1/8 inch thick for larger sizes.
1. Engraved legend with black letters on white face.
 2. Punched or drilled for mechanical fasteners.
- B. Fasteners for Nameplates and Signs: Self-tapping, stainless-steel screws or No. 10/32, stainless-steel machine screws with nuts and flat and lock washers.

2.3 MISCELLANEOUS IDENTIFICATION PRODUCTS

- A. Cable Ties: Fungus-inert, self-extinguishing, one-piece, self-locking, Type 6/6 nylon cable ties.
1. Minimum Width: 3/16 inch.
 2. Tensile Strength: 50 lb minimum.
 3. Temperature Range: Minus 40 to plus 185 deg F.
 4. Color: According to color-coding.
- B. Paint: Formulated for the type of surface and intended use.
1. Primer for Galvanized Metal: Single-component acrylic vehicle formulated for galvanized surfaces.
 2. Primer for Concrete Masonry Units: Heavy-duty-resin block filler.
 3. Primer for Concrete: Clear, alkali-resistant, binder-type sealer.
 4. Enamel: Silicone-alkyd or alkyd urethane as recommended by primer manufacturer.

PART 3 - EXECUTION

3.1 INSTALLATION

- A. Identification Materials and Devices: Install at locations for most convenient viewing without interference with operation and maintenance of equipment.
- B. Lettering, Colors, and Graphics: Coordinate names, abbreviations, colors, and other designations with corresponding designations in the Contract Documents or with those required by codes and standards. Use consistent designations throughout Project.
- C. Sequence of Work: If identification is applied to surfaces that require finish, install identification after completing finish work.
- D. Install painted identification according to manufacturer's written instructions and as follows:
 - 1. Clean surfaces of dust, loose material, and oily films before painting.
 - 2. Prime surfaces using type of primer specified for surface.
 - 3. Apply one intermediate and one finish coat of enamel.
- E. Color Banding Raceways and Exposed Cables: Band exposed and accessible raceways of the systems listed below:
 - 1. Bands: Pretensioned, wraparound plastic sleeves; colored adhesive tape; or a combination of both. Make each color band 2 inches wide, completely encircling conduit, and place adjacent bands of two-color markings in contact, side by side.
 - 2. Band Locations: At changes in direction, at penetrations of walls and floors, at 50-foot maximum intervals in straight runs, and at 25-foot maximum intervals in congested areas.
 - 3. Apply the following colors to the systems listed below:
 - a. Fire Alarm System: Red.
 - b. Fire-Suppression Supervisory and Control System: Red and yellow.
 - c. Combined Fire Alarm and Security System: Red and blue.
 - d. Security System: Blue and yellow.
 - e. Mechanical and Electrical Supervisory System: Green and blue.
 - f. Telecommunication System: Green and yellow.
- F. Caution Labels for Indoor Boxes and Enclosures for Power and Lighting: Install pressure-sensitive, self-adhesive labels identifying system voltage with black letters on orange background. Install on exterior of door or cover.
- G. Circuit Identification Labels on Boxes: Install labels externally.
 - 1. Exposed Boxes: Pressure-sensitive, self-adhesive plastic label on cover.
 - 2. Concealed Boxes: Plasticized card-stock tags.
 - 3. Labeling Legend: Permanent, waterproof listing of panel and circuit number or equivalent including voltage.
 - 4. Paint fire alarm junction box covers red.
- H. Paths of Underground Electrical Lines: During trench backfilling, for exterior underground power, control, signal, and communication lines, install continuous underground plastic line marker located directly above line at 6 to 8 inches below finished grade. Where width of multiple lines installed in a common trench or concrete envelope does not exceed 16 inches overall, use a single line marker. Install line marker for underground wiring, both direct-buried cables and cables in raceway.

- I. Color-Coding of Secondary Phase Conductors: Use the following colors for service, feeder, and branch-circuit phase conductors:
 - 1. 208/120-V Conductors:
 - a. Phase A: Black.
 - b. Phase B: Red.
 - c. Phase C: Blue.
 - d. Neutral White
 - 2. 480/277-V Conductors:
 - a. Phase A: Yellow.
 - b. Phase B: Brown.
 - c. Phase C: Orange.
 - d. Neutral Gray
 - 3. Factory apply color the entire length of conductors, except the following field-applied, color-coding methods may be used instead of factory-coded wire for sizes larger than No. 10 AWG:
 - a. Colored, pressure-sensitive plastic tape in half-lapped turns for a distance of 6 inches from terminal points and in boxes where splices or taps are made. Apply last two turns of tape with no tension to prevent possible unwinding. Use 1-inch-wide tape in colors specified. Adjust tape bands to avoid obscuring cable identification markings.
- J. Power-Circuit Identification: Metal tags or aluminum, wraparound marker bands for cables, feeders, and power circuits in vaults, pull and junction boxes, manholes, and switchboard rooms.
 - 1. Legend: 1/4-inch- steel letter and number stamping or embossing with legend corresponding to indicated circuit designations.
 - 2. Tag Fasteners: Nylon cable ties.
 - 3. Band Fasteners: Integral ears.
- K. Apply identification to conductors as follows:
 - 1. Conductors to Be Extended in the Future: Indicate source and circuit numbers.
 - 2. Multiple Power or Lighting Circuits in the Same Enclosure: Identify each conductor with source, voltage, circuit number, and phase. Use color-coding to identify circuits' voltage and phase.
 - 3. Multiple Control and Communication Circuits in the Same Enclosure: Identify each conductor by its system and circuit designation. Use a consistent system of tags, color-coding, or cable marking tape.
- L. Apply warning, caution, and instruction signs as follows:
 - 1. Warnings, Cautions, and Instructions: Install to ensure safe operation and maintenance of electrical systems and of items to which they connect. Install engraved plastic-laminated

- instruction signs with approved legend where instructions are needed for system or equipment operation. Install metal-backed butyrate signs for outdoor items.
2. Emergency Operation: Install engraved laminated signs with white legend on red background with minimum 3/8-inch- high lettering for emergency instructions on power transfer, load shedding, and other emergency operations.
- M. Equipment Identification Labels: Engraved plastic laminate. Install on each unit of equipment, including central or master unit of each system. This includes power, lighting, communication, signal, and alarm systems, unless units are specified with their own self-explanatory identification. Unless otherwise indicated, provide a single line of text with 1/2-inch- high lettering on 1-1/2-inch- high label; where two lines of text are required, use labels 2 inches high. Use white lettering on black field. Apply labels for each unit of the following categories of equipment using mechanical fasteners:
1. Panelboards, electrical cabinets, and enclosures.
 2. Access doors and panels for concealed electrical items.
 3. Electrical switchgear and switchboards.
 4. Disconnect switches.
 5. Enclosed circuit breakers.
 6. Power transfer equipment.
 7. Contactors.
 8. Remote-controlled switches.
 9. Dimmers.
 10. Control devices.
 11. Transformers.
 12. Battery racks.

END OF SECTION 26 05 53

SECTION 26 09 23 - LIGHTING CONTROL DEVICES

PART 1 - GENERAL

1.1 RELATED DOCUMENTS

- A. Drawings and general provisions of the Contract, including General and Supplementary Conditions and Division 1 Specification Sections, apply to this Section.

1.2 SUMMARY

- A. This Section includes the following lighting control devices:
 - 1. Time switches.
 - 2. Outdoor photoelectric switches.
 - 3. Switch-box occupancy sensors.
 - 4. Indoor occupancy sensors.
 - 5. Multipole contactors.
- B. Related Sections include the following:
 - 1. Division 16 Section "Wiring Devices" for wall-box dimmers and manual light switches.

1.3 DEFINITIONS

- A. LED: Light-emitting diode.
- B. PIR: Passive infrared.

1.4 SUBMITTALS

- A. Product Data: For each type of product indicated.
- B. Operation and Maintenance Data: For each type of product to include in emergency, operation, and maintenance manuals.

1.5 QUALITY ASSURANCE

- A. Electrical Components, Devices, and Accessories: Listed and labeled as defined in NFPA 70, Article 100, by a testing agency acceptable to authorities having jurisdiction, and marked for intended use.

1.6 COORDINATION

- A. Coordinate layout and installation of ceiling-mounted devices with other construction that penetrates ceilings or is supported by them, including light fixtures, HVAC equipment, fire-suppression system, and partition assemblies.

PART 2 - PRODUCTS

2.1 MANUFACTURERS

- A. In other Part 2 articles where titles below introduce lists, the following requirements apply to product selections:
 - 1. Manufacturers: Subject to compliance with requirements, provide products by on of the manufacturers specified.

2.2 GENERAL LIGHTING CONTROL DEVICE REQUIREMENTS

- A. Line-Voltage Surge Protection: An integral part of the devices for 120- and 277-V solid-state equipment. For devices without integral line-voltage surge protection, field-mounting surge protection shall comply with EIII C62.41 and with UL 1449.

2.3 TIME SWITCHES Paragon EC Series or Intermatic ET Series

- A. Manufacturers:
 - 1. Area Lighting Research, Inc.
 - 2. Fisher Pierce.
 - 3. Grasslin Controls Corporation.
 - 4. Intermatic, Inc.
 - 5. Leviton Mfg. Company Inc.
 - 6. Lightolier Controls: a Genlyte Company.
 - 7. Lithonia Lighting.
 - 8. Paragon Electric Co.
 - 9. Square D.
 - 10. TORK.
 - 11. Touchplate Technologies, Inc.
 - 12. Watt Stopper (The)
- B. Digital Time Switches: Electronic, solid-state programmable units with alphanumeric display complying with UL 917.
 - 1. Contact Configuration: As indicated.
 - 2. Contact Rating: 30-A inductive or resistive, 240-V ac .
 - 3. Program: Single channel, 2 on-off set points on a 24-hour schedule with skip-a-day weekly schedule.
 - 4. Circuitry: Allow connection of a photoelectric relay as substitute for on and off function of a program on selected channels.
 - 5. Astronomical Time: All channels.
 - 6. Battery Backup: For schedules and time clock.

2.4 OUTDOOR PHOTOELECTRIC SWITCHES

- A. Manufacturers:
1. Area Lighting Research, Inc.
 2. Fisher Pierce.
 3. Grasslin Controls Corporation.
 4. Intermatic, Inc.
 5. Lightolier Controls: a Genlyte Company.
 6. Lithonia Lighting.
 7. Paragon Electric Co.
 8. Square D.
 9. TORK.
 10. Touchplate Technologies, Inc.
 11. Watt Stopper (The)
- B. Description: Solid state, with SPST or DPST dry contacts rated for 1800-VA tungsten or 1000-VA inductive, to operate connected relay, contactor coils, and microprocessor input.
1. Light-Level Monitoring Range: 1.5 to 10 fc, with an adjustment for turn-on and turn-off levels within that range.
 2. Time Delay: 15-second minimum, to prevent false operation.
 3. Surge Protection: Metal-oxide varistor type, complying with IEEE C62.41 for Category A1 locations.
 4. Mounting: Twist lock complying with IEEE C136.10 with base-and-stem mounting or stem-and-swivel mounting accessories as required to direct sensor to the North sky exposure.

2.5 INDOOR PHOTOELECTRIC SWITCHES – where specified.

- A. Manufacturers:
1. Allen Bradley/Rockwell Automation.
 2. Area Lighting Research, Inc.
 3. Cutler-Hammer; Eaton Corporation.
 4. Fisher Pierce.
 5. Grasslin Controls Corporation.
 6. Intermatic, Inc.
 7. Lithonia Lighting.
 8. MicroLite Corporation.
 9. Novitas, Inc.
 10. Paragon Electric Co.
 11. Square D.
 12. TORK.
 13. Touchplate Technologies, Inc.
 14. Watt Stopper (The)
- B. Ceiling-Mounting Photoelectric Switch: Solid-state, light-level sensor unit, with separate relay unit mounted on luminaire, to detect changes in lighting levels that are perceived by the eye. Cadmium sulfide photoresistors are not acceptable.
1. Sensor Output: contacts rated to operate the associated relay, complying with UL 773A. Sensor shall be powered from the relay unit.

2. Relay Unit: Dry contacts rated for 20-A ballast load at 120 and 277 Volts AC, for 13-A tungsten at 120-V ac, and for 1 hp at 120-V ac. Power supply to sensor shall be 24-V dc, 150 mA, Class 2 power source as defined by NFPA 70.
3. Light-Level Monitoring Range: 10 to 200 fc, with an adjustment for turn-on and turn-off levels within that range.
4. Time Delay: Adjustable from 5 to 300 seconds to prevent cycling, with dead band adjustment.
5. Indicator: Two LEDs to indicate the beginning of on and off cycles.

2.6 SWITCH-BOX OCCUPANCY SENSORS

- A. Manufacturers:
1. Bryant Electric; a Hubbell Company.
 2. Hubbell Lighting Inc.
 3. Leviton Mfg. Company
 4. Lightolier Controls: a Genlyte Company.
 5. Lithonia Lighting.
 6. MYTECH Corporation.
 7. Novitas, Inc.
 8. RAB Electric Manufacturing Inc.
 9. Sensor Switch, Inc.
 10. TORK.
 11. Unico Electronics; A Hubbell Company.
 12. Watt Stopper (The)
- B. Description: PIR type with integral power-switching contacts rated for 800 W at 120-V ac, suitable for LED drivers, or 1/6-hp motors; and rated for 1000 W at 277-V ac, suitable for LED drivers, or 1/3-hp motors, minimum.

2.7 INDOOR OCCUPANCY SENSORS

- A. Manufacturers:
1. Hubbell Lighting Inc.
 2. Leviton Mfg. Company
 3. Lithonia Lighting.
 4. MYTECH Corporation.
 5. Novitas, Inc.
 6. RAB Electric Manufacturing Inc.
 7. Sensor Switch, Inc.
 8. TORK.
 9. Uneco Electronics; A Hubbell Company.
 10. Watt Stopper (The)
- B. General Description: Wall- or ceiling-mounting, solid-state units with a separate relay unit.
1. Operation: Unless otherwise indicated, turn lights on when covered area is occupied and off when unoccupied; with a time delay for turning lights off, adjustable over a minimum range of 1 to 30 minutes.

2. Sensor Output: Contacts rated to operate the connected relay, complying with UL 773A. Sensor shall be powered from the relay unit.
 3. Relay Unit: Dry contacts rated for 20-A ballast load at 120- and 277-V ac, for 13-A tungsten at 120-V ac, and for 1 hp at 120-V ac. Power supply to sensor shall be 24-V dc, 150-mA, Class 2 power source as defined by NFPA 70.
 4. Mounting:
 - a. Sensor: Suitable for mounting in any position on a standard outlet box.
 - b. Relay: Externally mounted through a 1/2-inch knockout in a standard electrical enclosure.
 - c. Time-Delay and Sensitivity Adjustments: Recessed and concealed behind hinged door.
 5. Indicator: LED, to show when motion is being detected during testing and normal operation of the sensor.
 6. Bypass Switch: Override the on function in case of sensor failure.
 7. Automatic Light-Level Sensor: Adjustable from 2 to 200 fc; keeps lighting off when selected lighting level is present.
 8. Fail Safe; In case of sensor failure, lighting fixtures shall remain on.
- C. Dual-Technology Type: Ceiling mounting; detect occupancy by using a combination of PIR and ultrasonic detection methods in area of coverage. Particular technology or combination of technologies that controls on and off functions shall be selectable in the field by operating controls on unit.
1. Sensitivity Adjustment: Separate for each sensing technology.
 2. Detector Sensitivity: Detect occurrences of 6-inch minimum movement of any portion of a human body that presents a target of at least 36 sq. in., and detect a person of average size and weight moving at least 12 inches in either a horizontal or a vertical manner at an approximate speed of 12 inches/s.
 3. Detection Coverage (Standard Room): Detect occupancy anywhere within a circular area of 1000 sq. ft. when mounted on a 96-inch- high ceiling.

2.8 MULTIPOLE CONTACTORS

- A. Manufacturers:
1. Allen Bradley/Rockwell Automation.
 2. ASCO Power Technologies, LP; a division of Emerson Electric Co.
 3. Cutler-Hammer; Eaton Corporation.
 4. Fisher Pierce.
 5. GE Industrial Systems; Total Lighting Control.
 6. Grasslin Controls Corporation.
 7. Hubbell Lighting Inc.
 8. Lithonia Lighting.
 9. MicroLite Corporation.
 10. TORK.
 11. Touchplate Technologies, Inc.
 12. Watt Stopper (The)
- B. Description: Electrically operated and electrically held.

1. Current Rating for Switching: Listing or rating consistent with type of load served, including tungsten filament, inductive, and high-inrush ballast (ballast with 15 percent or less total harmonic distortion of normal load current).
2. Control-Coil Voltage: Match control power source.

2.9 CONDUCTORS AND CABLES

- A. Power Wiring to Supply Side of Remote-Control Power Sources: Not smaller than No. 12 AWG, complying with Division 16 Section "Conductors and Cables."

PART 3 - EXECUTION

3.1 SENSOR INSTALLATION

- A. Install and aim sensors in locations to achieve at least 90 percent coverage of areas indicated. Do not exceed coverage limits specified in manufacturer's written instructions.

3.2 WIRING INSTALLATION

- A. Wiring Method: Comply with Division 16 Section "Conductors and Cables." Minimum conduit size shall be 1/2 inch.
- B. Wiring within Enclosures: Bundle, lace, and train conductors to terminal points. Separate power-limited and nonpower-limited conductors according to conductor manufacturer's written instructions.
- C. Size conductors according to lighting control device manufacturer's written instructions, unless otherwise indicated.
- D. Splices, Taps, and Terminations: Make connections only on numbered terminal strips in junction, pull, and outlet boxes; terminal cabinets; and equipment enclosures.
- E. Tighten electrical connectors and terminals according to manufacturer's published torque-tightening values.
- F. Tighten electrical connectors and terminals according to manufacturer's published torque-tightening values. If manufacturer's torque values are not indicated, use those specified in UL 486A and UL 486B.

3.3 IDENTIFICATION

- A. Identify components and power and control wiring according to Division 16 Section "Electrical Identification."
- B. Label time switches and contactors with a unique designation.

3.4 FIELD QUALITY CONTROL

- A. Perform the following field tests and inspections and prepare test reports:
 - 1. After installing time switches and sensors, and after electrical circuitry has been energized, adjust and test for compliance with requirements.
 - 2. Operational Test: Verify actuation of each sensor and adjust time delays.
- B. Remove and replace lighting control devices where test results indicate that they do not comply with specified requirements.
- C. Additional testing and inspecting, at Contractor's expense, will be performed to determine compliance of replaced or additional work with specified requirements.

3.5 ADJUSTING

- A. Occupancy Adjustments: When requested within 12 months of date of Substantial Completion, provide on-site assistance in adjusting sensors to suit actual occupied conditions. Provide up to two visits to site outside normal occupancy hours for this purpose.

END OF SECTION 26 09 23

SECTION 26 24 16 - ENCLOSED SWITCHES

PART 1 - GENERAL

1.1 RELATED DOCUMENTS

- A. Drawings and general provisions of the Contract, including General and Supplementary Conditions and Division 1 Specification Sections, apply to this Section.

1.2 SUMMARY

- A. This Section includes the following:
 - 1. Distribution panelboards.
 - 2. Lighting and appliance branch-circuit panelboards.

1.3 DEFINITIONS

- A. EMI: Electromagnetic interference.
- B. GFCI: Ground-fault circuit interrupter.
- C. RFI: Radio-frequency interference.
- D. RMS: Root mean square.
- E. SPDT: Single pole, double throw.

1.4 SUBMITTALS

- A. Product Data: For each type of switch, circuit breaker, accessory, and component indicated. Include dimensions and manufacturers' technical data on features, performance, electrical characteristics, ratings, and finishes.
- B. Shop Drawings: For each switch and circuit breaker.
 - 1. Dimensioned plans, elevations, sections, and details, including required clearances and service space around equipment. Show tabulations of installed devices, equipment features, and ratings. Include the following:
 - a. Enclosure types and details for types other than NEMA 250, Type 1.
 - b. Bus configuration, current and voltage ratings.
 - c. Short-circuit current rating of panelboards and overcurrent protective devices.
 - d. Features, characteristics, ratings, and factory settings of individual overcurrent protective devices and auxiliary components.
 - 2. Wiring Diagrams: Power, signal, and control wiring.

- C. Field quality-control test reports including the following:
 - 1. Test procedures used.
 - 2. Test results that comply with requirements.
 - 3. Results of failed tests and corrective action taken to achieve test results that comply with requirements.
- D. Panelboard Schedules: For installation in panelboards. Submit final versions after load balancing.
- E. Operation and Maintenance Data: For panelboards and components to include in emergency, operation, and maintenance manuals.

1.5 QUALITY ASSURANCE

- A. Source Limitations: Obtained panelboards, overcurrent protective devices, component, and accessories through one source from a single manufacturer.
- B. Product Options: Drawings indicated size, profiles, and dimensional requirements of panelboards and are based on the specified system indicate.
- C. Electrical Components, Devices, and Accessories: Listed and labeled as defined in NFPA 70, Article 100, by a testing agency acceptable to authorities having jurisdiction, and marked for intended use.
- D. Comply with NEMA PB1.
- E. Comply with NFPA 70.

1.6 PROJECT CONDITIONS

- A. Environmental Limitations: Rate equipment for continuous operation under the following conditions, unless otherwise indicated:
 - 1. Ambient Temperature: Not less than minus 22 deg F and not exceeding 104 deg F.
 - 2. Altitude: Not exceeding 6600 feet.

1.7 COORDINATION

- A. Coordinate layout and installation of switches, circuit breakers, and components with other construction, including conduit, piping, equipment, and adjacent surfaces. Maintain required workspace clearances and required clearances for equipment access doors and panels.

1.8 EXTRA MATERIAL

- A. Furnish extra material described below that match products installed and that are packaged with protective covering for storage and identified with labels describing contents.
 - 1. Keys: Six spares for each type of panelboard cabinet lock.

PART 2 - PRODUCTS

2.1 MANUFACTURERS

- A. Manufacturers: Subject to compliance with requirements, provided products by one of the following:
 - 1. Panelboards, Overcurrent Protective Devices, Controllers Contactors and Accessories:
 - a. General Electric Co.; Electrical Distribution & Protection Div.
 - b. Square D.
 - c. Eaton.

2.2 MANUFACTURED UNITS

- A. Enclosures: Flush and surface mounted cabinets. NEMA PB 1, Type 1.
 - 1. Rated for environmental conditions at installed location.
 - a. Outdoor Locations: NEMA 250, Type 3R.
 - b. Other Wet or Damp Indoor Locations: NEMA 250, Type 4.
 - 2. Front: Secured to box with concealed trim clamps. For surface-mounted fronts, match box dimensions; for flush-mounted fronts, overlap box.
 - 3. Finish: Manufacturer's standard enamel finish over corrosion-resistant treatment or primer coat.
 - 4. Directional Card: With transparent protective cover mounted in metal frame, inside of panelboard door.
- B. Phase and Ground Buses:
 - 1. Material: Hard drawn copper, 98 percent conductivity.
 - 2. Equipment Ground Bus: Adequate for feeder and branch-circuit equipment ground conductors; bond to box.
 - 3. Isolated Equipment Ground Bus: Adequate for branch-circuit equipment ground conductors; insulated from box.
- C. Conductor Connectors: Suitable for use with conductor material.
 - 1. Main and Neutral Lugs: Compression type.
 - 2. Ground Lugs and Bus Configured Terminators: Compression type.
- D. Future Devices: Mounting brackets, bus connections, and necessary appurtenances required for future installation of devices.

2.3 PANELBOARD SHORT-CIRCUIT RATING

- A. Fully rated to interrupt symmetrical short-circuit current available at terminals.

2.4 DISTRIBUTION PANELBOARDS

- A. Doors: Secured with vault-type latch with tumbler lock; keyed alike. Omit for fused-switch panelboards.
- B. Main Overcurrent Protective Devices: Circuit breaker.

- C. Branch Overcurrent Protective Devices:
 - 1. For Circuit-Breaker Frame Sizes 125A and Smaller: Bolt-on circuit breakers.
 - 2. For Circuit-Breaker Frame Sizes Larger than 125A: Bolt-on circuit breakers; plug-in circuit breakers where individual positive-locking device requires mechanical release for removal.

2.5 LIGHTING AND APPLIANCE BRANCH-CIRCUIT PANELBOARDS

- A. Branch Overcurrent Protective Devices: Bolt-on circuit breakers, replaceable without disturbing adjacent units.
- B. Doors” concealed hinges; secured with flush latch with tumbler lock; keyed alike.

2.6 OVERCURRENT PROTECTIVE DEVICES

- A. Molded-Case Circuit Breaker: UL 489, with interrupting capacity to meet available fault currents.
 - 1. Thermal-Magnetic Circuit Breakers: Inverse time-current element for low-level overloads, and instantaneous magnetic trip element for short circuits. Adjustable magnetic trip setting for circuit-breaker frame sizes 250 A and larger.
 - 2. Adjustable Instantaneous-Trip Circuit Breakers: Magnetic trip element with front-mounted, field-adjustable trip setting.
 - 3. Electronic trip-unit circuit breakers shall have RMS sensing; field-replaceable rating plug; and with the following field-adjustable settings:
 - a. Instantaneous trip.
 - b. Long and short time pick up levels.
 - c. Long and short-time time adjustments.
 - d. Ground-fault pickup level, time delay, and I²t response.
 - 4. Current-Limiting Circuit Breakers: Frame sizes 400A and smaller; let-through ratings less than NEMA FU 1, RK-5.
 - 5. GFCI Circuit Breakers: Single and two-pole configurations with 5-mA trip sensitivity.
- B. Molded Case Circuit Breaker Features and Accessories: Stand frame sizes, trip ratings, and number of poles.
 - 1. Lugs: Mechanical style, suitable for number, size, trip ratings, and conductor materials.
 - 2. Application Listing: Appropriate for application: Type SWD for switching fluorescent lighting loads; Type HACR for heating, air-conditioning, and refrigerating equipment.
 - 3. Ground-Fault Protection: Integrally mounted relay and trip unit with adjustable pickup and time-delay settings, push-to-test feature, and ground-fault indicator.
 - 4. Shunt Trip: 120-V trip coil energized from separate circuit, set to trip at 75 percent of rated voltage.
 - 5. Multipole units enclosed in a single housing or factory-assembled to operate as a single unit.

2.7 ACCESSORY COMPONENTS AND FEATURES

- A. Furnish accessory set including tools and miscellaneous items required for overcurrent protective device test, inspection, maintenance and operation.

PART 3 - EXECUTION

3.1 INSTALLATION

- A. Install panelboards and accessories according to NEMA PB 1.1.
- B. Mount top of trim 74 inches above finished floor, unless otherwise indicated.
- C. Mount plumb and rigid without distortion of box. Mount recessed panelboards with fronts uniformly flushed with wall finish.
- D. Install overcurrent protective devices and controllers.
 - 1. Set field-adjustable switches and circuit-breaker trip ranges.
- E. Install filler plates in unused spaces.
- F. Stub four 1-inch empty conduits from panelboard into accessible ceiling space or space designated to be ceiling space in the future.
- G. Arrange conductors in gutters and within panelboard into associated circuit groups and bundle and wrap with wire ties after completing load balancing.
- H. All panel cans and covers with-in the same space shall be the same height.

3.2 IDENTIFICATION

- A. Identify field-installed conductors, interconnecting wiring, and components; provide warning signs as specified in Division 26 Section "Electrical Identification."
- B. Create a directory to indicate installed circuit loads after balancing panelboard loads. Obtain approval before installing. Use a computer or typewriter to create directory; handwritten directories are **NOT ACCEPTABLE**. Provide room being served identification for each circuit.
- C. Panel board Nameplates: Label each panelboard with engraved metal or laminated-plastic nameplate mounted with corrosion -resistant screws.

3.3 CONNECTIONS

- A. Ground equipment according to Division 26 Section "Grounding and Bonding."
- B. Connect wiring according to Division 26 Section "Conductors and Cables."

3.4 FIELD QUALITY CONTROL

- A. Prepare for acceptance tests as follows:

1. Test insulation resistance for each enclosed switch, circuit breaker, component, and control circuit.
 2. Test continuity of each line- and load-side circuit.
- B. Testing Agency: Engage a qualified testing and inspecting agency to perform the following field test and prepare test reports:
- C. Perform the following field test and inspections and prepare test reports:
1. Perform each electrical test and visual and mechanical inspection stated in NETA ATS, Section 7.5 for switches and Section 7.6 for molded-case circuit breakers. Certify compliance with test parameters.
 2. Correct malfunctioning units on -site, where possible, and retest to demonstrate compliance; otherwise replace with new units and retest.
- D. Load Balancing: After Substantial Completion, but not more than 69 days after Final Acceptance, measure load balancing and make circuit changes.
1. Measure as directed during period of normal system loading.
 2. Perform load-balancing circuit changes outside normal occupancy/working schedule of the facility and at time directed. Avoid disrupting critical 24-hour services such as fax machines and on-line data processing, computing, transmitting, and receiving equipment.
 3. After circuit changes, recheck loads during normal load period. Record all load readings before and after changes and submit test reports.
 4. Tolerance: Difference exceeding 29 percent between phase loads, within a panelboard, is not acceptable. Rebalance and recheck as necessary to meet this minimum requirement.
- E. Infrared Scanning: After Substantial Completion, but not more than 60 days after Final Acceptance, perform an infrared scanning of each panelboard. Remove panel fronts so joints and connections are accessible to portable scanner.
1. Follow-Infrared Scanning: Perform an additional follow-up infrared scan of each panelboard 11 months after date of Substantial Completion.
 2. Instrument: Use an infrared scanning device designed to measure temperature or to detect significant deviations from normal values. Provide calibration record for device.
 3. Record of Infrared Scanning: Prepare a certified report that identifies panelboards checked and describes scanning results. Include notation of deficiencies detected, remedial action taken, and observations after remedial action.

3.5 ADJUSTING

- A. Set field-adjustable switches and circuit-breaker trip ranges.

3.6 CLEANING

- A. On completion of installation, inspect interior and exterior of enclosures. Remove paint splatters and other spots. Vacuum dirt and debris; do not use compressed air to assist in cleaning. Repair exposed surfaces to match original finish.

END OF SECTION 262416

SECTION 26 27 26 - WIRING DEVICES

PART 1 - GENERAL

1.1 RELATED DOCUMENTS

- A. Drawings and general provisions of the Contract, including General and Supplementary Conditions and Division 1 Specification Sections, apply to this Section.

1.2 SUMMARY

- A. This Section includes the following:
 - 1. Single and duplex receptacles, ground-fault circuit interrupters, integral surge suppression units, and isolated-ground receptacles.
 - 2. Single- and double-pole snap switches and dimmer switches.
 - 3. Device wall plates.
 - 4. Pin and sleeve connectors and receptacles.
 - 5. Floor service outlets, poke-through assemblies, service poles, and multioutlet assemblies.

1.3 DEFINITIONS

- A. EMI: Electromagnetic interference.
- B. GFCI: Ground-fault circuit interrupter.
- C. PVC: Polyvinyl chloride.
- D. RFI: Radio-frequency interference.
- E. TVSS: Transient voltage surge suppressor.
- F. UTP: Unshielded twisted pair.

1.4 SUBMITTALS

- A. Product Data: For each type of product indicated.
- B. Shop Drawings: List of legends and description of materials and process used for pre-marking wall plates.
- C. Samples: One of each type of device and wall plate specified, in each color specified.
- D. Field quality-control test reports.

1.5 QUALITY ASSURANCE

- A. Source Limitations: Obtain each type of wiring device through one source from a single manufacturer.
- B. Electrical Components, Devices, and Accessories: Listed and labeled as defined in NFPA 70, Article 100, by a testing agency acceptable to authorities having jurisdiction, and marked for intended use.
- C. Comply with NFPA 70.

1.6 COORDINATION

- A. Receptacles for Owner-Furnished Equipment: Match plug configurations.
 - 1. Cord and Plug Sets: Match equipment requirements.

PART 2 - PRODUCTS

2.1 MANUFACTURERS

- A. Manufacturers: Subject to compliance with requirements, provided products by one of the following:
 - 1. Wiring Devices:
 - a. Hubbell Incorporated; Wiring Device-Kellems.
 - b. Leviton Mfg. Company Inc.
 - c. Pass Seymour/Legrand; Wiring Devices Div.
 - 2. Multioutlet Assemblies:
 - a. Hubbell Incorporated; Wiring Device-Kellems,
 - b. Wiremold Company (The).

2.2 RECEPTACLES

- A. Straight-Blade-Type Receptacles: (Leviton 5362 or approved equal). Comply with NEMA WD 1, NEMA WD 6, DSCC W-C-596G, and UL 498.
- B. Straight-Blade: Heavy -Duty grade.
- C. GFCI Receptacles: Straight blade, non-feed-through type, Heavy-Duty grade, with integral NEMA WD6, Configuration 5-20R duplex receptacle; complying with UL 498 and UL 943. Design units for installation in a 2-3/4-inch- deep outlet box without an adapter. (Leviton Model # GFNT2 or approved equal.)
- D. Isolated Ground Receptacle: Straight blade, Heavy Duty grade, duplex receptacle, with equipment grounding contacts connected only to the green grounding screw terminal of device and with inherent electrical isolation from mounting strap. (Leviton Model #5362-IG or approved equal.)
 - 1. Devices: Listed and labeled as isolated-ground receptacles.

2. Isolation Method: Integral to receptacle construction and not dependent on removable parts.
- E. TVSS Receptacles: Straight blade, NEMA WD6, Configuration 5-20R, with integral TVSS in line to ground, line to neutral, and neutral to ground.
1. TVSS Components: Multiple metal-oxide varistors; with a nominal clamp level rating of 500 volts and minimum single transient pulse energy dissipation of 140 J line to neutral, and 70 J line to ground and neutral to ground.
 2. Active TVSS Indication: Visual only with light visible in face of device to indicate device is “active” or “no longer in service.”
 3. Identification: Distinctive marking on face of device to denote TVSS-type unit.
- F. USB Receptacles: See site plan symbol schedule.
- G. Tamper Resistant: Leviton TBR 20.

2.3 CORD AND PLUG SETS

- A. Description: Match voltage and current ratings and number of conductors to requirements of equipment being connected.
1. Cord: Rubber-insulated, stranded-copper conductors, with Type SOW-A jacket; with green-insulated grounding conductor and equipment-rating ampacity plus a minimum of 30 percent.
 2. Plug: Nylon body and integral cable-clamping jaws. Match cord and receptacle type for connection.

2.4 SWITCHES (Leviton Models 1221-2, 1222-2, 1223-2 and 1224-2 or approved equal.)

- A. Single- and Double-Pole Switches: Comply with DSCC W-C-896F and UL 20.
- B. Snap Switches: Heavy -Duty grade, quiet type.
- C. Combination Switch and Receptacle: Both devices in a single gang unit with plaster ears and removable tab connector that permit separate or common feed connection.
1. Switch 20A, 120/277 Volts AC.
 2. Receptacle: NEMA WD6, Configuration 5-15R.
- D. Dimmer Switches: Modular, full-wave, solid-state units with integral, quiet on/off switches and audible frequency and EMI/RFI filters.
1. Control: Continuously adjustable slider; with single-pole or three-way switching to suit connections.
 2. LED Lamp Dimmers: Modular, 277V, 50 Hz with continuously adjustable rotary knob, toggle switch, or slider; single pole with soft tap or other quiet switch; EMI/RFI filter to eliminate interference; and 5-inch wire connecting leads.

2.5 WALL PLATES

- A. Single and combination types to match corresponding wiring devices.
 - 1. Plate-Securing Screws: Metal with head color to match plate finish.
 - 2. Material for Finished Spaces: 0.035-inch- thick, satin-finished stainless steel.
 - 3. Material for Unfinished Spaces: Galvanized steel.
 - 4. Material for Wet Locations: Thermoplastic with spring-loaded lift cover, and listed and labeled for use in "wet locations."

2.6 MULTIOUTLET ASSEMBLIES

- A. Components of Assemblies: Products from a single manufacturer designed for use as a complete, matching assembly of raceways and receptacles.
- B. Raceway Material: Metal, with manufacturer's standard finish.
- C. Wire: No. 12 AWG.

2.7 FINISHES

- A. Color:
 - 1. Wiring Devices Connected to Normal Power System: As selected by Owner/Engineer.
 - 2. TVSS Devices: Blue.
 - 3. Isolated-Ground Receptacles: As specified above, with orange triangle on face.

PART 3 - EXECUTION

3.1 INSTALLATION

- A. Install devices and assemblies' level, plumb, and square with building lines.
- B. Install wall dimmers to achieve indicated rating after derating for ganging according to manufacturer's written instructions.
- C. Install unshared neutral conductors on line and load side of dimmers according to manufacturers' written instructions.
- D. Arrangement of Devices: Unless otherwise indicated, mount flush, with long dimension vertical, and with grounding terminal of receptacles on top. Group adjacent switches under single, multi-gang wall plates.
- E. Remove wall plates and protect devices and assemblies during painting.
- F. Adjust locations of floor service outlets and service poles to suit arrangement of partitions and furnishings.

3.2 IDENTIFICATION

- A. Comply with Division 26 Section “Electrical Identification.”
 - 1. Receptacles: Identify panelboard and circuit number form which served. Use hot, stamped or engraved machine printing with black-filled lettering on face of plate, and durable wire markers or tags inside outlet boxes.

3.3 CONNECTIONS

- A. Ground equipment according to Division 16 Section "Grounding and Bonding."
- B. Connect wiring according to Division 16 Section "Conductors and Cables."
- C. Tighten electrical connectors and terminals according to manufacturer's published torque-tightening values. If manufacturer's torque values are not indicated use those specified in UL 486A and UL 486B

3.4 FIELD QUALITY CONTROL

- A. Perform the following field tests and inspections and prepare test reports:
 - 1. After installing wiring devices and after electrical circuitry has been energized, test for proper polarity, ground continuity, and compliance with requirements.
 - 2. Test GFCI operation with both local and remote fault simulations according to manufacturer's written instructions.
- B. Remove malfunctioning units, replace with new units, and retest as specified above.

END OF SECTION 26 27 26

SECTION 26 43 13 - TRANSIENT VOLTAGE SUPPRESSION

PART 1 - GENERAL

1.1 RELATED DOCUMENTS

- A. Drawings and general provisions of the Contract, including General and Supplementary Conditions and Division 1 Specification Sections, apply to this Section.

1.2 SUMMARY

- A. This Section includes transient voltage surge suppressors for low-voltage power, control, and communication equipment.
- B. Related Sections include the following:
 - 1. Division 16 Section "Switchboards" for factory-installed transient voltage surge suppressors.

1.3 SUBMITTALS

- A. Product Data: For each type of product indicated. Include rated capacities; shipping, installed, and operating weights; furnished specialties; and accessories.
- B. Maintenance Data: For transient voltage suppression devices to include in maintenance manuals specified in Division 1.
- C. Warranties: Special warranties specified in this Section.

1.4 QUALITY ASSURANCE

- A. Source Limitations: Obtain suppression devices and accessories through one source from a single manufacturer.
- B. Electrical Components, Devices, and Accessories: Listed and labeled as defined in NFPA 70, Article 100, by a testing agency acceptable to authorities having jurisdiction, and marked for intended use.

1.5 PROJECT CONDITIONS

- A. Existing Utilities: Do not interrupt utilities serving facilities occupied by Owner or others unless permitted under the following conditions and then only after arranging to provide temporary utility services according to requirements indicated:
 - 1. Notify Architect not less than two weeks in advance of proposed utility interruptions.
 - 2. Do not proceed with utility interruptions without Architect's written permission.

- B. Service Conditions: Rate surge protective devices for continuous operation under the following conditions, unless otherwise indicated:
1. Maximum Continuous Operating Voltage: Not less than 115 percent of nominal system operating voltage.
 2. Operating Temperature: 30 to 120 deg F.
 3. Humidity: 0 to 85 percent, noncondensing.
 4. Altitude: Less than 20,000 feet above sea level.

1.6 COORDINATION

- A. Coordinate location of field-mounted surge suppressors to allow adequate clearances for maintenance.

1.7 WARRANTY

- A. General Warranty: Special warranties specified in this Article shall not deprive Owner of other rights Owner may have under other provisions of the Contract Documents and shall be in addition to, and run concurrent with, other warranties made by Contractor under requirements of the Contract Documents.

1.8 EXTRA MATERIALS

- A. Furnish extra materials described below that match products installed and that are packaged with protective covering for storage and identified with labels describing contents.
1. Replaceable Protection Modules: One of each size and type installed.

PART 2 - PRODUCTS

2.1 SERVICE ENTRANCE SUPPRESSORS: Current Technology SEL200 or Cutler Hammer CPS-M

- A. Surge Protective Device Description: Modular design with field-replaceable modules and the following features and accessories:
1. Fabrication using bolted compression lugs for internal wiring.
 2. Integral disconnect switch.
 3. Redundant suppression circuits.
 4. Redundant replaceable modules.
 5. Arrangement with wire connections to phase buses, neutral bus, and ground bus.
 6. Red and green LED indicator lights for power and protection status.
 7. Audible alarm, with silencing switch, to indicate when protection has failed.
 8. One set of dry contacts rated at 5 a and 250-V ac, for remote monitoring of protection status. Coordinate with building power monitoring and control system.
 9. Surge-event operations counter.
- B. Peak Single-Impulse Surge Current Rating: 400 kA per phase.

- C. Connection Means: Permanently wired.
- D. Protection modes clamping voltage for grounded wye circuits with voltages of 480Y/277 and 208Y/120; 3-phase, 4-wire circuits, shall be as follows:
 - 1. Line to Neutral: 800 V for 480Y/277 and 400 V for 208Y/120.
 - 2. Line to Ground: 800 V for 480Y/277 and 400 V for 208Y/120.
 - 3. Neutral to Ground: 800 V for 480Y/277 and 400 V for 208Y/120.

2.2 CONTROL AND DATA TERMINALS

- A. Protectors for copper data and telephone conductors entering the building from the outside shall be as recommended by the manufacturer for the type of line being protected.

2.3 ENCLOSURES

- A. NEMA 250, with type matching the enclosure of panel or device being protected.

PART 3 - EXECUTION

3.1 INSTALLATION OF SURGE PROTECTIVE DEVICES

- A. Install devices at service entrance on load side, with ground lead bonded to service entrance ground.
- B. Install devices for panelboard and auxiliary panels with conductors between suppressor and points of attachment as short and straight as possible. Do not exceed manufacturer's recommended lead length. Do not bond neutral and ground.
 - 1. Provide multipole, 15-A circuit breaker as a dedicated disconnect for the suppressor, unless otherwise indicated or recommended by the suppressor manufacturer.

3.2 CONNECTIONS

- A. Tighten electrical connectors and terminals according to manufacturer's published torque-tightening values

3.3 FIELD QUALITY CONTROL

- A. Testing: Perform the following field quality-control testing:
 - 1. After installing surge protective devices, but before electrical circuitry has been energized, test for compliance with requirements.
 - 2. Complete startup checks according to manufacturer's written instructions.
 - 3. Perform each visual and mechanical inspection and electrical test stated in NETA ATS, Section 7.19. Certify compliance with test parameters.

- B. Repair or replace malfunctioning units. Retest after repairs or replacements are made.
- C. Manufacturer's Field Service: Engage a factory-authorized service representative to inspect field-assembled components and equipment installation, including piping and electrical connections. Report results in writing.
 - 1. Verify that electrical wiring installation complies with manufacturer's installation requirements.

3.4 DEMONSTRATION

- A. Engage a factory-authorized service representative to train Owner's maintenance personnel to adjust, operate, and maintain surge protective devices.
 - 1. Train Owner's maintenance personnel on procedures and schedules for maintaining suppressors.
 - 2. Review data in maintenance manuals. Refer to Specification Section "Contract Closeout."
 - 3. Review data in maintenance manuals. Refer to Specification Section "Operation and Maintenance Data."
 - 4. Schedule training with Owner, through Architect, with at least seven days' advance notice.

END OF SECTION 26 43 13

SECTION 26 43 13 - TRANSIENT VOLTAGE SUPPRESSION

PART 1 - GENERAL

1.1 RELATED DOCUMENTS

- A. Drawings and general provisions of the Contract, including General and Supplementary Conditions and Division 1 Specification Sections, apply to this Section.

1.2 SUMMARY

- A. This Section includes transient voltage surge suppressors for low-voltage power, control, and communication equipment.
- B. Related Sections include the following:
 - 1. Division 16 Section "Switchboards" for factory-installed transient voltage surge suppressors.

1.3 SUBMITTALS

- A. Product Data: For each type of product indicated. Include rated capacities; shipping, installed, and operating weights; furnished specialties; and accessories.
- B. Maintenance Data: For transient voltage suppression devices to include in maintenance manuals specified in Division 1.
- C. Warranties: Special warranties specified in this Section.

1.4 QUALITY ASSURANCE

- A. Source Limitations: Obtain suppression devices and accessories through one source from a single manufacturer.
- B. Electrical Components, Devices, and Accessories: Listed and labeled as defined in NFPA 70, Article 100, by a testing agency acceptable to authorities having jurisdiction, and marked for intended use.

1.5 PROJECT CONDITIONS

- A. Existing Utilities: Do not interrupt utilities serving facilities occupied by Owner or others unless permitted under the following conditions and then only after arranging to provide temporary utility services according to requirements indicated:
 - 1. Notify Architect not less than two weeks in advance of proposed utility interruptions.
 - 2. Do not proceed with utility interruptions without Architect's written permission.

- B. Service Conditions: Rate surge protective devices for continuous operation under the following conditions, unless otherwise indicated:
1. Maximum Continuous Operating Voltage: Not less than 115 percent of nominal system operating voltage.
 2. Operating Temperature: 30 to 120 deg F.
 3. Humidity: 0 to 85 percent, noncondensing.
 4. Altitude: Less than 20,000 feet above sea level.

1.6 COORDINATION

- A. Coordinate location of field-mounted surge suppressors to allow adequate clearances for maintenance.

1.7 WARRANTY

- A. General Warranty: Special warranties specified in this Article shall not deprive Owner of other rights Owner may have under other provisions of the Contract Documents and shall be in addition to, and run concurrent with, other warranties made by Contractor under requirements of the Contract Documents.

1.8 EXTRA MATERIALS

- A. Furnish extra materials described below that match products installed and that are packaged with protective covering for storage and identified with labels describing contents.
1. Replaceable Protection Modules: One of each size and type installed.

PART 2 - PRODUCTS

2.1 SERVICE ENTRANCE SUPPRESSORS: Current Technology SEL200 or Cutler Hammer CPS-M

- A. Surge Protective Device Description: Modular design with field-replaceable modules and the following features and accessories:
1. Fabrication using bolted compression lugs for internal wiring.
 2. Integral disconnect switch.
 3. Redundant suppression circuits.
 4. Redundant replaceable modules.
 5. Arrangement with wire connections to phase buses, neutral bus, and ground bus.
 6. Red and green LED indicator lights for power and protection status.
 7. Audible alarm, with silencing switch, to indicate when protection has failed.
 8. One set of dry contacts rated at 5 a and 250-V ac, for remote monitoring of protection status. Coordinate with building power monitoring and control system.
 9. Surge-event operations counter.
- B. Peak Single-Impulse Surge Current Rating: 400 kA per phase.

- C. Connection Means: Permanently wired.
- D. Protection modes clamping voltage for grounded wye circuits with voltages of 480Y/277 and 208Y/120; 3-phase, 4-wire circuits, shall be as follows:
 - 1. Line to Neutral: 800 V for 480Y/277 and 400 V for 208Y/120.
 - 2. Line to Ground: 800 V for 480Y/277 and 400 V for 208Y/120.
 - 3. Neutral to Ground: 800 V for 480Y/277 and 400 V for 208Y/120.

2.2 CONTROL AND DATA TERMINALS

- A. Protectors for copper data and telephone conductors entering the building from the outside shall be as recommended by the manufacturer for the type of line being protected.

2.3 ENCLOSURES

- A. NEMA 250, with type matching the enclosure of panel or device being protected.

PART 3 - EXECUTION

3.1 INSTALLATION OF SURGE PROTECTIVE DEVICES

- A. Install devices at service entrance on load side, with ground lead bonded to service entrance ground.
- B. Install devices for panelboard and auxiliary panels with conductors between suppressor and points of attachment as short and straight as possible. Do not exceed manufacturer's recommended lead length. Do not bond neutral and ground.
 - 1. Provide multipole, 15-A circuit breaker as a dedicated disconnect for the suppressor, unless otherwise indicated or recommended by the suppressor manufacturer.

3.2 CONNECTIONS

- A. Tighten electrical connectors and terminals according to manufacturer's published torque-tightening values

3.3 FIELD QUALITY CONTROL

- A. Testing: Perform the following field quality-control testing:
 - 1. After installing surge protective devices, but before electrical circuitry has been energized, test for compliance with requirements.
 - 2. Complete startup checks according to manufacturer's written instructions.
 - 3. Perform each visual and mechanical inspection and electrical test stated in NETA ATS, Section 7.19. Certify compliance with test parameters.

- B. Repair or replace malfunctioning units. Retest after repairs or replacements are made.
- C. Manufacturer's Field Service: Engage a factory-authorized service representative to inspect field-assembled components and equipment installation, including piping and electrical connections. Report results in writing.
 - 1. Verify that electrical wiring installation complies with manufacturer's installation requirements.

3.4 DEMONSTRATION

- A. Engage a factory-authorized service representative to train Owner's maintenance personnel to adjust, operate, and maintain surge protective devices.
 - 1. Train Owner's maintenance personnel on procedures and schedules for maintaining suppressors.
 - 2. Review data in maintenance manuals. Refer to Specification Section "Contract Closeout."
 - 3. Review data in maintenance manuals. Refer to Specification Section "Operation and Maintenance Data."
 - 4. Schedule training with Owner, through Architect, with at least seven days' advance notice.

END OF SECTION 26 43 13

SECTION 26 51 19 – LED INTERIOR LIGHTING

PART 1 - GENERAL

1.1 SUMMARY

- A. This Section includes the following:
 - 1. Interior solid-state luminaires that use LED technology
 - 2. Lighting fixture supports.
 - 3. Exit signs.
- B. Related Sections include the following:
 - 1. Section 26093 “Lighting Control Devices” for automatic control of lighting, including time switches, photoelectric relays, occupancy sensors, and multipole lighting relays and contactors.

1.2 DEFINITIONS

- A. CCT: Correlated color temperature.
- B. CRI: Color rendering index.
- C. Fixture: See “Luminaire.”
- D. IP: International Protection or Ingress Protection Rating.
- E. LED: Light Emitting Diode
- F. Lumen: Measured output of lamp and luminaire, or both.
- G. Luminaire: Complete lighting unit, including lamp, reflector, and housing.

1.3 SUBMITTALS

- A. Product Data: For each type of lighting fixture scheduled, arranged in order of fixture designation. Include data on features, accessories, finishes, and the following:
 - 1. Physical description of fixture, including dimensions and verification of indicated parameters.
 - 2. Fluorescent and high-intensity-discharge ballasts.
 - 3. Lamps.
- B. Shop Drawings: Show details of nonstandard or custom fixtures. Indicate dimensions, weights, methods of field assembly, components, features, and accessories.

- C. Operation and Maintenance Data: For lighting equipment and fixtures to include in emergency, operation, and maintenance manuals. In addition to items specified in Specification Section "Operation and Maintenance Data," include the following:

- 1. Catalog data for each fixture. Include the diffuser, ballast, and lamps installed in that fixture.

1.4 INFORMATION SUBMITTAL

- A. Coordination Drawings: Reflected ceiling plan(s) and other details, drawn to scale and coordinated with each other, using input from installers of the items involved:
- B. Seismic Qualification Certificates: For luminaires, accessories, and components, from manufacturer.
- C. Product Certificates: For each type of luminaire.
- D. Sample warranty.

1.5 CLOSEOUT SUBMITTALS

- A. Operation and maintenance data.

1.6 WARRANTY

- A. Warranty: Manufacturer and Installer agree to repair or replace component of luminaires that fail in materials or workmanship within specified warranty period.
- B. Warranty Period for all LED Fixtures: Five(5) years from date of Substantial Completion.

1.7 EXTRA MATERIALS

- A. Furnish extra materials described below that match products installed and that are packaged with protective covering for storage and identified with labels describing contents.
 - 1. Drivers: 1 for every 100 of each type and rating installed. Furnish at least one of each type.

1.8 QUALITY ASSURANCE

- A. Electrical Components, Devices, and Accessories: Listed and labeled as defined in NFPA 70, Article 100, by a testing agency acceptable to authorities having jurisdiction, and marked for intended use.
- B. Comply with NFPA 70.
- C. NFPA 101 Compliance: Comply with visibility and luminance requirements for exit signs.

1.9 COORDINATION

- A. Coordinate layout and installation of lighting fixtures and suspension system with other construction that penetrates ceilings or is supported by them, including HVAC equipment, fire-suppression system, and partition assemblies.

PART 2 - PRODUCTS

2.1 LUMINAIRE REQUIREMENTS

- A. Electrical Components, Devices, and Accessories: Listed and labeled as defined in NFPA 70, by a qualified testing agency, and marked for intended location and application.
- B. NRTL Compliance: Luminaires for hazardous locations shall be listed and labeled for indicated class and division of hazard by an NRTL.
- C. FM Global Compliance: Luminaires for hazardous locations shall be listed and labeled for indicated class and division of hazard by FM Global.
- D. Recessed Fixtures: Comply with NEMA LE 4.
- E. CRI of minimum 80 CCT at 4000K (See Fixture Schedule).
- F. Rated lamp life of 50,000 hours minimum or equal to specified fixtures which is more.
- G. Lamps dimmable from 100 percent to 0 percent of maximum light output.
- H. Internal driver.
- I. Nominal Operating Voltage: 120 Volt, 1 phase, 60hz.
 - 1. Lens Thickness: At least 0.125 inch (3.175 mm) minimum unless otherwise indicated.

2.2 MATERIALS

- A. Metal Parts: Free of burrs and sharp corners and edges.
- B. Sheet Metal Components: Steel, unless otherwise indicated. Form and support to prevent warping and sagging.
- C. Doors, Frames, and Other Internal Access: Smooth operating, free of light leakage under operating conditions, and designed to permit re-lamping without use of tools. Designed to prevent doors, frames, lenses, diffusers, and other components from falling accidentally during re-lamping and when secured in operating position.
- D. Reflecting surfaces shall have minimum reflectance as follows, unless otherwise indicated:
 - 1. White Surfaces: 85 percent.
 - 2. Specular Surfaces: 83 percent.
 - 3. Diffusing Specular Surfaces: 75 percent.

4. Laminated Silver Metallized Film: 90 percent.

E. Plastic Diffusers, Covers, and Globes:

1. Acrylic Lighting Diffusers: 100 percent virgin acrylic plastic. High resistance to yellowing and other changes due to aging, exposure to heat, and UV radiation.
 - a. Lens Thickness: At least 0.125 inch minimum unless different thickness is scheduled.
 - b. UV stabilized.
2. Glass: Annealed crystal glass, unless otherwise indicated.
3. Lens Thickness: At least 0.125 inch (3.175 mm) minimum unless otherwise indicated.

2.3 METAL FINISHES

- A. Variations in finishes are unacceptable in the same piece. Variations in finishes of adjoining components are acceptable if they are within the range of approved Samples and if they can be and are assembled or installed to minimize contrast.

2.4 LUMINAIRE SUPPORTS COMPONENTS

2.5 EXIT SIGNS

- A. General: Comply with authorities having jurisdiction for sign colors and lettering size.
- B. Internally Lighted Signs:
1. Lamps for AC Operation: Light-emitting diodes, 70,000 hours minimum of rated lamp life.
- C. Self-Powered Exit Signs (Battery Type): Integral automatic charger in a self-contained power pack.
1. Battery: Sealed, maintenance-free, nickel-cadmium type with special warranty.
 2. Charger: Fully automatic, solid-state type with sealed transfer relay.
 3. Operation: Relay automatically energizes lamp from battery when circuit voltage drops to 80 percent of nominal voltage or below. When normal voltage is restored, relay disconnects lamps from battery, and battery is automatically recharged and floated on charger.

2.6 FIXTURE SUPPORT COMPONENTS

- A. Comply with Division 26 Section "Basic Electrical Materials and Methods" for channel- and angle-iron supports, and nonmetallic channel and angle supports.
- B. Single-Stem Hangers: 1/2-inch steel tubing with swivel ball fittings and ceiling canopy. Finish same as fixture.

- C. Twin-Stem Hangers: Two, 1/2-inch steel tubes with single canopy designed to mount a single fixture. Finish same as fixture.
- D. Wires: Soft temper, zinc-coated, 12 gage.
- E. Wires For Humid Spaces: Annealed stainless steel, 12 gage.
- F. Rod Hangers: 3/16-inch- minimum diameter, cadmium-plated, threaded steel rod.

2.7 FINISHES

- A. Fixtures: Manufacturers' standard, unless otherwise indicated.
 1. Paint Finish: Applied over corrosion-resistant treatment or primer, free of defects.
 2. Metallic Finish: Corrosion resistant.

PART 3 - EXECUTION

3.1 INSTALLATION

- A. Comply with NECA 1.
- B. Luminaire Installation: Set level, plumb, and square with ceilings and walls. Install lamps in each fixture.
- C. Install lamps in each luminaire.
- D. Suspended Fixture Support:
 1. Pendants and Rods: Where longer than 48 inches, brace to limit swinging.
 2. Stem-Mounted, Single-Unit Fixtures: Suspend with twin-stem hangers.
 3. Continuous Rows: Use tubing or stem for wiring at one point and tubing or rod for suspension for each unit length of fixture chassis, including one at each end.
 4. Continuous Rows: Suspend from cable.
- E. Ceiling Grid Mounted Luminaires:
 1. Secure to any required outlet box.
 2. Secure luminaire using approved fasteners in a minimum of four locations, spaced near corners of luminaire.
- F. Identify systems components, wiring, cabling, and terminals. Comply with requirements for identification specified in Section 260533 "Electrical Identification".

3.2 CONNECTIONS

- A. Tighten electrical connectors and terminals according to manufacturer's published torque-tightening values.

3.3 FIELD QUALITY CONTROL

- A. Inspect each installed fixture for damage. Replace damaged fixtures and components.
- B. Verify normal operation of each fixture after installation.
- C. Test for Emergency Lighting: Interrupt power supply to demonstrate proper operation. Verify normal transfer to battery power source and retransfer to normal.
- D. Corroded Fixtures: During warranty period, replace fixtures that show any signs of corrosion.

END OF SECTION 26 51 19

**ATTACHMENT B
TO FOLLOW
IMMEDIATELY**

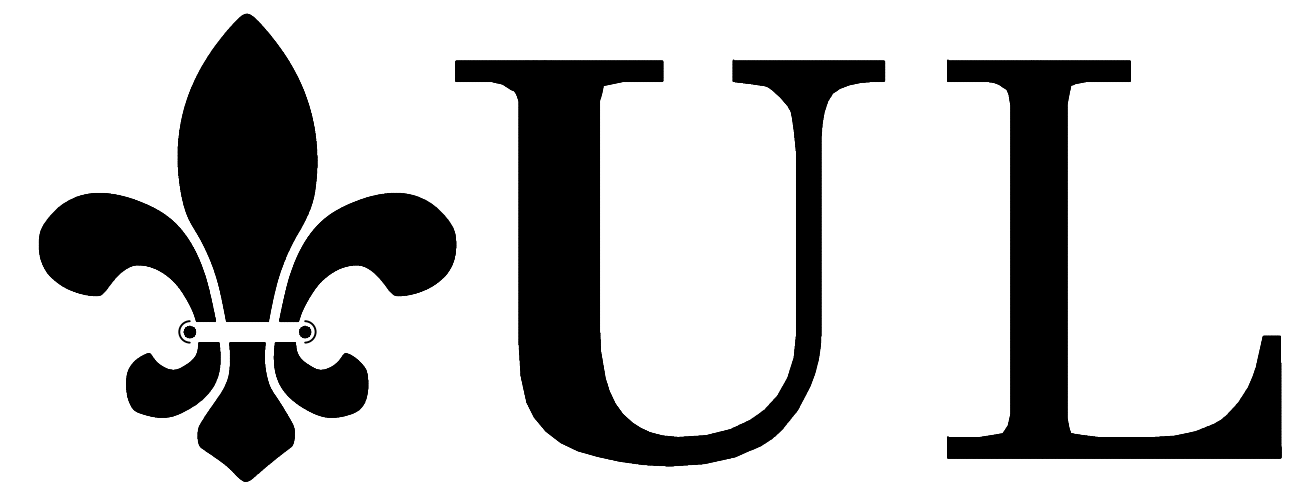

UNIVERSITY OF LOUISIANA
AT LAFAYETTE
NEW IBERIA RESEARCH CENTER
BUILDING 30 - 3RD FLOOR
RENOVATION FOR (IT)

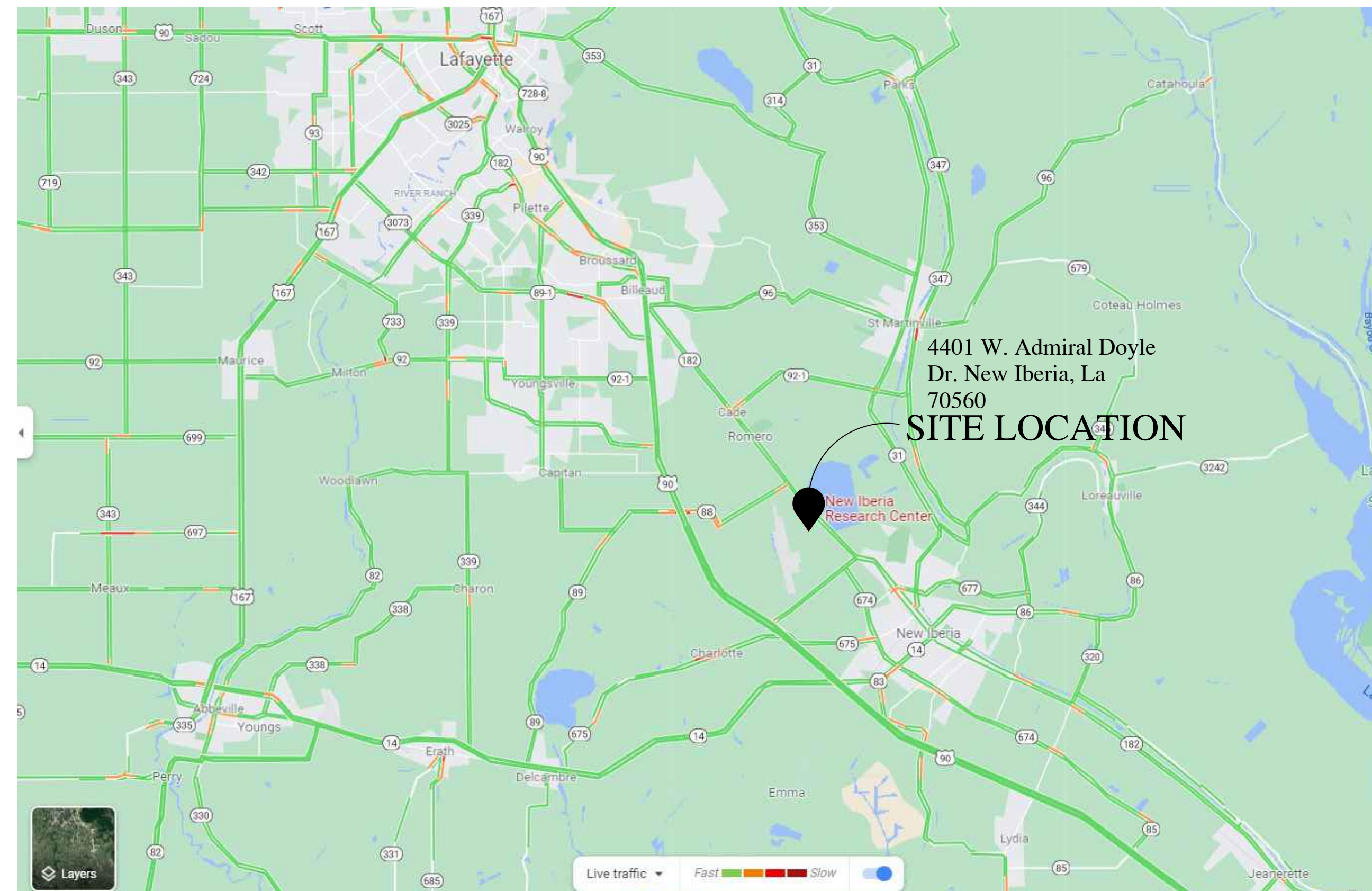

SEPTEMBER 2023

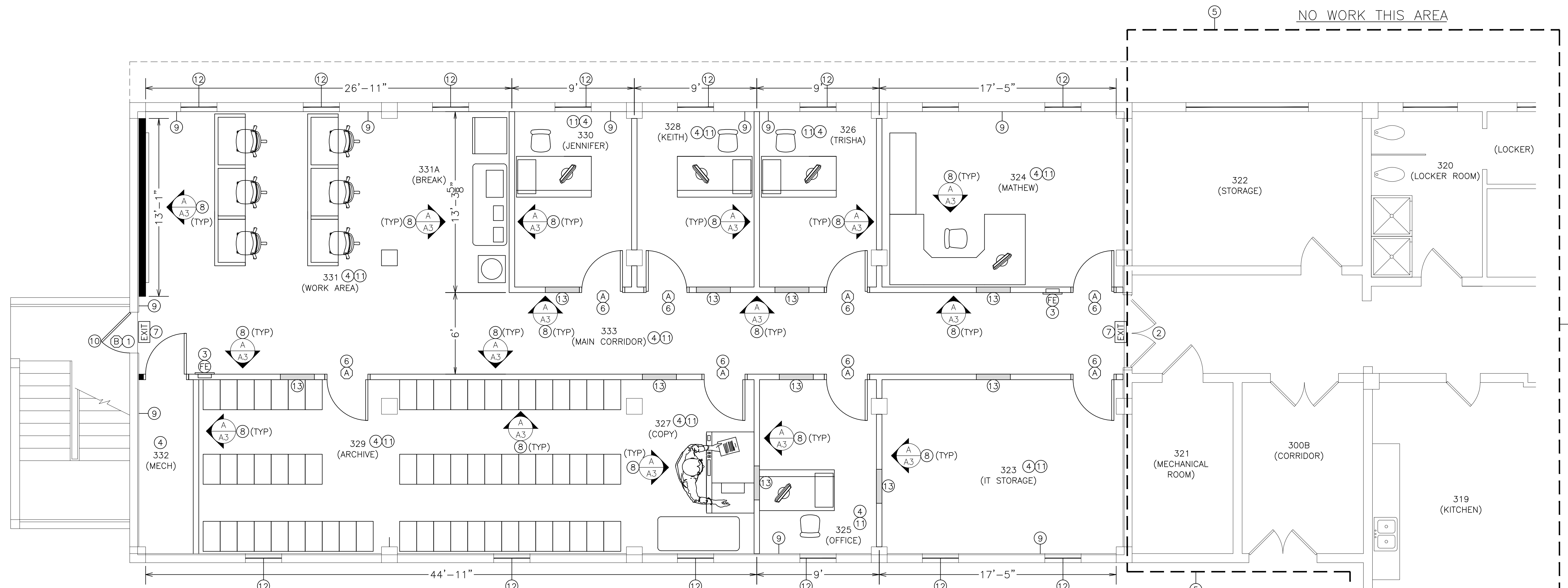

GENERAL NOTES:

- A. CONTRACTOR SHALL LAYOUT ALL WALLS AND CONTACT THE NIRC OWNER/ENGINEER FOR LAYOUT APPROVAL PRIOR TO ANY WALL CONSTRUCTION.
- B. ALL CONTRACTOR EMPLOYEES MUST SUBMIT TO BACKGROUND CHECKS PAID FOR BY NIRC. ALL CONTRACTOR EMPLOYEES MUST POSSESS VALID SOCIAL SECURITY INFORMATION ON FORM PROVIDED BY NIRC. ALL CONTRACTOR EMPLOYEES SHALL MEET ALL MEDICAL TESTING REQUIREMENTS IN REGARDS TO "TB" AND "MEASLES" PERFORMED BY NIRC.
- C. ALL WORK SHALL BE DONE BETWEEN THE HOURS OF 7:00 AM AND 4:00 PM (WEEKDAYS ONLY). NO WORK SHALL BE DONE AFTER HOURS OR DURING HOLIDAYS WITHOUT THE WRITTEN CONSENT OF OWNER. CONTRACTOR SHALL REQUEST AFTER HOUR WORK 2 DAYS PRIOR TO WORK, AND WILL NOT BE GUARANTEED THAT WORK WILL BE APPROVED.
- D. CONTRACTOR SHALL BE RESPONSIBLE FOR ALL CUTTING AND PATCHING.
- E. ALL FURNITURE PROVIDED BY OWNER UNLESS OTHERWISE NOTED.

KEYNOTES:

- ① - REMOVE EXISTING EXTERIOR DOOR AND REPLACE WITH NEW FLAT PANEL HOLLOW METAL DOOR COMPLETE WITH HINGES, CLOSURE AND PANIC BAR SYSTEM. PROVIDE THRESHOLD WITH RUBBER SEAL. REFER TO DOOR SCHEDULE.
- ② - EXISTING DOOR TO REMAIN. NO ENTRY DURING CONSTRUCTION.
- ③ - INSTALL NEW RECESSED FIRE EXTINGUISHER CABINETS WHERE SHOWN.
- ④ - FLOORS: OWNER SHALL CLEAN AND FILL IN ALL DEFECTS, SAND AND SEAL FLOOR WITH TWO (2) LAYERS OF SEALER. OWNER SHALL PROVIDE AND INSTALL 4", RUBBER BASE MOLDING GLUED TO WALL. COLOR SHALL BE BLACK.
- ⑤ - NO WORK THIS AREA. AREA OFF LIMITS TO WORKERS. CONTRACTOR SHALL PROVIDE TEMPORARY TOILET FACILITIES OUTSIDE. ACCESS SHALL BE FROM WEST END EXTERIOR DOOR.
- ⑥ - PROVIDE INTERIOR PRE-HUNG DOOR, WITH 3 HINGES COMPLETE WITH METAL FRAME. SWING AND FRAME SHALL BE PRIMED. OWNER TO PROVIDE LOCKS. COORDINATE SWING PRIOR TO ORDERING OF DOORS. COORDINATE WITH OWNER FOR DOOR AND ROOM NUMBERING SIGNAGE. REFER TO DOOR SCHEDULE.
- ⑦ - PROVIDE BATTERY TYPE EXIT SIGN ABOVE DOOR IN CEILING. PROVIDE POWER TO SIGNAGE.
- ⑧ - NEW WALLS SHALL CONSIST OF APPROXIMATELY 12 FOOT +/- (FLOOR TO DECK), 3-5/8", 20 GAUGE METAL STUDS, INSULATION IN ALL WALLS, AND 5/8" TYPE "X" SHEET ROCK. ALL NEW WALL STUDS SHALL EXTEND FROM FLOOR TO ROOF DECK STRUCTURE ABOVE. ALL SHEET ROCK SHALL EXTEND FROM FLOOR TO ROOF DECK. CONTRACTOR SHALL TAPE ALL JOINTS, FLOAT, AND PREP WALL FOR PAINTING. PRIME AND PAINTING BY OWNER.
- ⑨ - OWNER SHALL PRIME AND PAINT EXISTING PERIMETER INTERIOR AND EXTERIOR BLOCK WALL. CONTRACTOR SHALL REPAIR ALL DAMAGED AREAS DURING CONSTRUCTION.
- ⑩ - THIS DOOR SHALL BE UTILIZED FOR ENTRY INTO WORK SPACE.
- ⑪ - INSTALL NEW 2'X2' SUSPENDED CEILING SYSTEM WHERE SHOWN ON SHEET A2. COORDINATE NEW CEILING INSTALLATION WITH NEW POWER, LIGHTING, AND HVAC PIPING AND DUCTWORK.
- ⑫ - EXISTING EXTERIOR WINDOWS TO REMAIN.
- ⑬ - PROVIDE 30"X24" OPENINGS ABOVE CEILING AT ALL WALLS TO PROVIDE AIRFLOW PATH BACK TO MECHANICAL ROOM.

**BUILDING 30 - PARTIAL 3RD FLOOR
NEW LAYOUT PLAN**

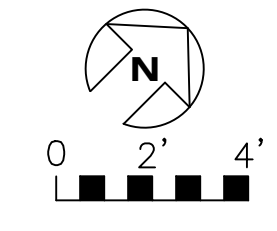

- LEGEND:**
- EXISTING WALLS
 - NEW INTERIOR WALLS
 - EXISTING WINDOWS
 - EXISTING DOORS
 - NEW DOORS
 - EXIT SIGN CEILING MOUNTED
 - FIRE EXTINGUISHER W/ RECESSED CABINET
 - DOOR DESIGNATION. REFER TO SHEET A3.

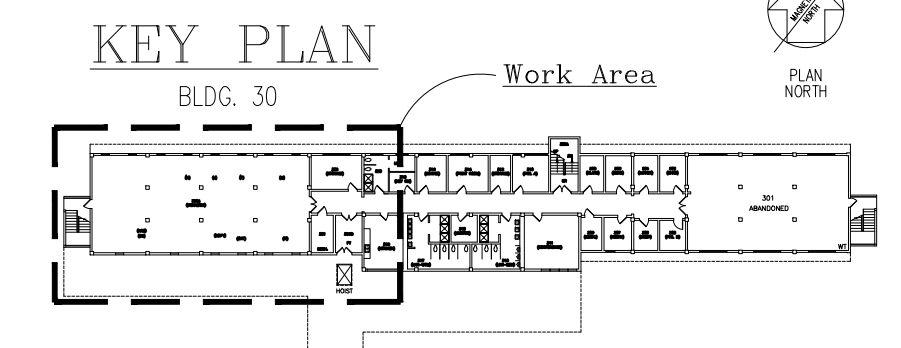

GENERAL NOTES		
NO:	REVISIONS:	DATE:

**NEW IBERIA RESEARCH CENTER
BUILDING 30 - 3RD FLOOR RENOVATION FOR (IT)**

UL FACILITY MANAGEMENT
THE UNIVERSITY OF LOUISIANA AT LAFAYETTE
P.O. BOX 43646
LAFAYETTE, LOUISIANA 70504

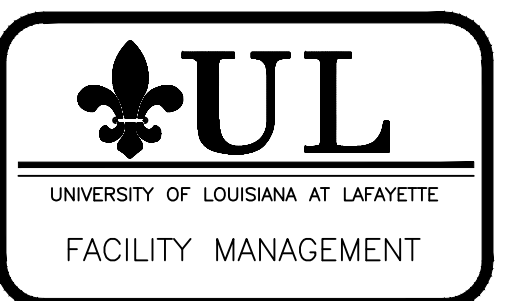

PROJECT NO:	SHEET:
DATE: SEPT. 2023	A1
SCALE: 1" = 0"	

NIRC - BUILDING 30 - 3RD FLOOR RENOVATION FOR IT-ARCH

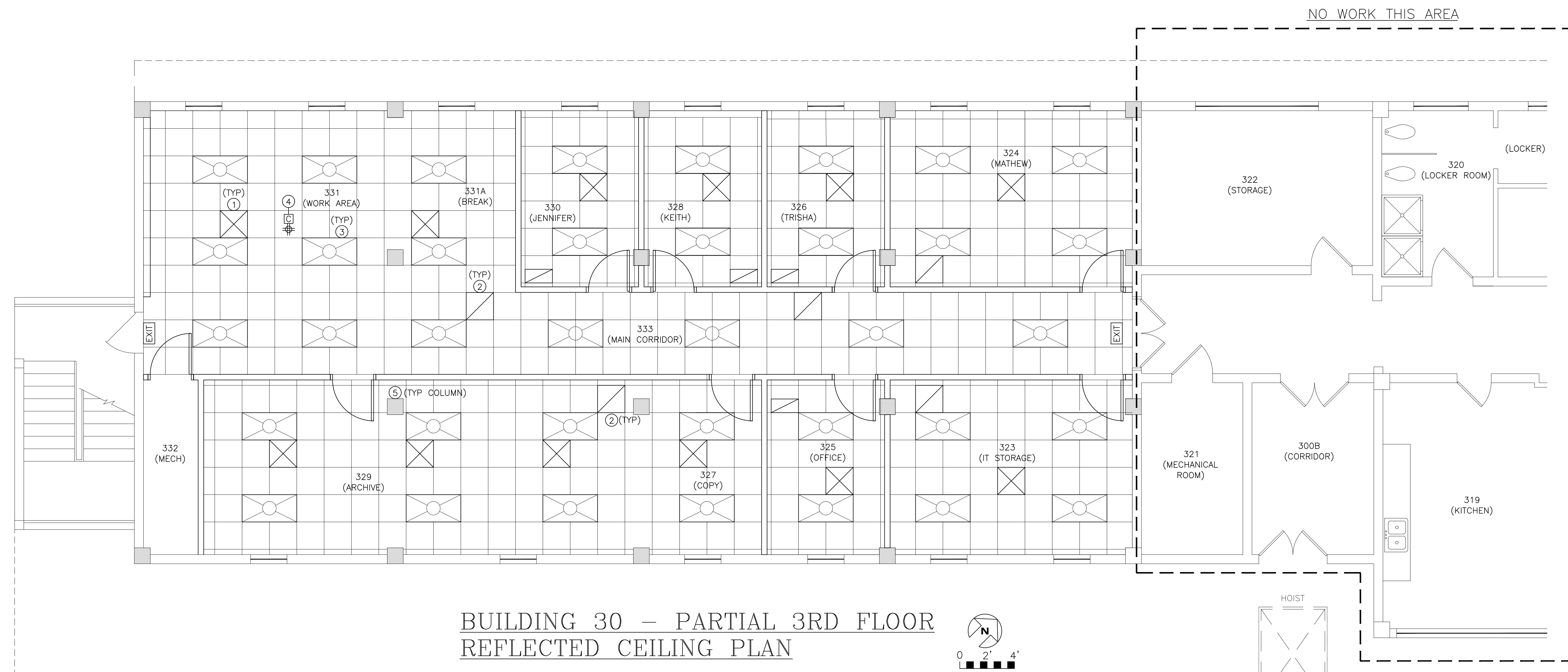

**BUILDING 30 – PARTIAL 3RD FLOOR
REFLECTED CEILING PLAN**

GENERAL NOTES:

- A. FURNISH AND INSTALL A 2' x 2' SUSPENDED CEILING SYSTEM AS PER PLANS AND SPECIFICATIONS AND TO THE LAYOUT PROVIDED.
- B. NEW CEILING SYSTEM SHALL CONSIST OF HANGERS, ALUMINUM CEILING GRID, AND REVEALED EDGE CEILING PANELS.
- C. CEILING TILE: ARMSTRONG – 1728, NON-DIRECTIONAL, MOISTURE AND SAG RESISTANT) 9-GAUGE WIRE HANGERS.
- D. CEILING HANGERS SHALL BE ANCHORED TO FRAMING AT STRUCTURE ABOVE NO MORE THAN 4' ON CENTER BOTH WAYS. ADDITIONAL HANGERS (2) MINIMUM AT EACH LIGHT FIXTURE, AT GRID MAIN RUNNER JOINTS, AND NO MORE THAN 8" FROM WALL. ALL HANGERS SHALL BE PRE-DRILLED TO ROOF STRUCTURE.
- E. COORDINATE CEILING SYSTEM WITH OTHER TRADES. DO NOT INSTALL CEILING SYSTEM UNTIL ALL ABOVE CEILING WORK HAS BEEN COMPLETED, INSPECTED, AND APPROVED BY THE UNIVERSITY.
- F. EXTEND EXISTING ARCHIVES CEILING TO NEW WALL LOCATION. COORDINATE WITH OTHER TRADES FOR HVAC, LIGHTING, AND SPRINKLER. MATCH EXISTING LAYOUT, CEILING GRID, AND CEILING TILES. COORDINATE CEILING GRID WITH LIGHT FIXTURE LAYOUT.
- G. AN ABOVE CEILING INSPECTION SHALL BE PERFORMED BY NEW IBERIA RESEARCH CENTER (NIRC) PRIOR TO CEILING TILE INSTALLATION.
- H. COORDINATE CEILING SYSTEM WITH OTHER TRADES. DO NOT INSTALL CEILING SYSTEM UNTIL ALL ABOVE CEILING WORK HAS BEEN COMPLETED, INSPECTED, AND APPROVED BY THE UNIVERSITY. DO NOT INSTALL CEILING GRID UNTIL WALLS HAVE BEEN FINISHED AND PAINTED WITH ONE COAT.
- I. COORDINATE CEILING TILE INSTALLATION WITH TRADES FOR CEILING DEVICES.
- J. AN ABOVE CEILING INSPECTION SHALL BE PERFORMED BY THE UNIVERSITY PRIOR TO CEILING TILE INSTALLATION.
- K. ALL DAMAGED OR BENT CEILING GRID SHALL BE REPLACED PRIOR TO CEILING TILE INSTALLATION. ALL STAINED, DAMAGED, OR TILES CUT SHORT SHALL BE REPLACED.
- L. COORDINATE SUSPENDED CEILING SYSTEM WITH SHEET ROCK CEILING INSTALLATION.
- M. DO NOT INSTALL SUSPENDED CEILING SYSTEM UNTIL ALL EXISTING CEILING OPENINGS HAVE BEEN REPAIRED, CLOSED UP, AND FIRE CAULKED.

KEYNOTES:

- ① – REFER TO HVAC PLANS FOR FINAL LOCATION OF SUPPLY GRILLE. (TYPICAL ALL AREAS).
- ② – REFER TO HVAC PLANS FOR FINAL LOCATION OF RETURN GRILLE. (TYPICAL ALL AREAS).
- ③ – COORDINATE NEW GRID WITH LIGHTING REQUIREMENTS. (TYPICAL ALL AREAS).
- ④ – COORDINATE LOCATION OF POWER, DATA, AND PHONE OUTLETS WITH OWNER.
- ⑤ – PROVIDE BORDER AROUND EXISTING COLUMNS SECURED TO COLUMN. (TYPICAL ALL EXPOSED COLUMNS).

SYMBOL LEGEND:

- 2'x4' LIGHTING (LED TYPE)
- HVAC GRILLE – SUPPLY
- HVAC GRILLE – RETURN
- 2'x2' CEILING TILE (WHITE) W/ T-BAR (WHITE)
- CEILING MOUNTED EXIT SIGNAGE.
- CEILING MOUNTED OUTLET – DATA/PHONE
- CEILING MOUNTED OUTLET – QUAD TYPE.

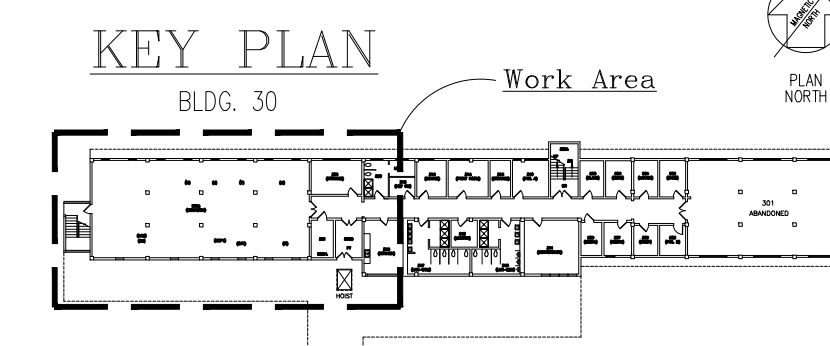

GENERAL NOTES		
NO:	REVISIONS:	DATE:

**NEW IBERIA RESEARCH CENTER
BUILDING 30 - 3RD FLOOR RENOVATION FOR (IT)**

UL FACILITY MANAGEMENT
THE UNIVERSITY OF LOUISIANA AT LAFAYETTE
P.O. BOX 43646
LAFAYETTE, LOUISIANA 70504



PROJECT NO: SHEET:
DATE: SEPT. 2023
SCALE: 1" = 0"
A2

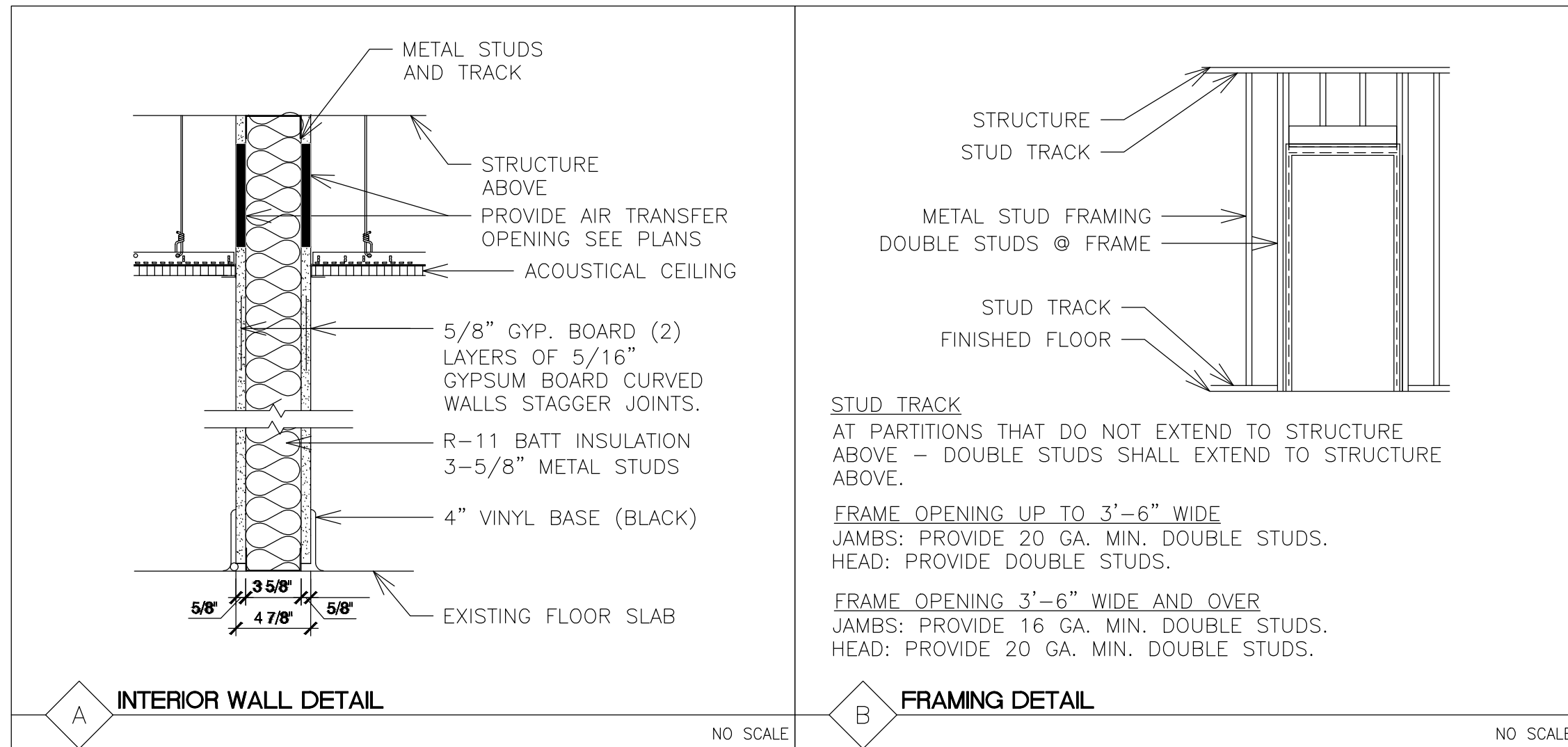

ROOM		DOOR SCHEDULE											NOTES	②
NO.	TYPE	WID.	HT.	THK.	MATERIAL	FRAME	DOOR STYLE	RATING	CLOSURE	FUNCTION	REMARKS			
300A	CORRIDOR	3'-0"	6'-8"	1- 3/4"	HOLLOW METAL	METAL	FLAT, METAL	N/A	YES	ENTRANCE	PANIC TO EXIT, CYLINDRICAL LOCK (FIGURE 8 CORE), CLOSURE PULL/PANIC		B	
323	IT STOR.	3'-0"	6'-8"	1- 3/4"	HOLLOW METAL	METAL	FLAT, METAL	N/A	NO	STORAGE	LOCKS BY OWNER	1	A	
324	OFFICE-MATHEW	3'-0"	6'-8"	1- 3/4"	HOLLOW METAL	METAL	FLAT, METAL	N/A	NO	ENTRANCE	LOCKS BY OWNER	1	A	
325	OFFICE-SPARE	3'-0"	6'-8"	1- 3/4"	HOLLOW METAL	METAL	FLAT, METAL	N/A	NO	ENTRANCE	LOCKS BY OWNER	1	A	
326	OFFICE-TRISHA	3'-0"	6'-8"	1- 3/4"	HOLLOW METAL	METAL	FLAT, METAL	N/A	NO	ENTRANCE	LOCKS BY OWNER	1	A	
327	COPY ROOM	3'-0"	6'-8"	1- 3/4"	HOLLOW METAL	METAL	FLAT, METAL	N/A	NO	ENTRANCE	LOCKS BY OWNER	1	A	
328	OFFICE-KEITH	3'-0"	6'-8"	1- 3/4"	HOLLOW METAL	METAL	FLAT, METAL	N/A	NO	ENTRANCE	LOCKS BY OWNER	1	A	
329	ARCHIVE STORAGE	3'-0"	6'-8"	1- 3/4"	HOLLOW METAL	METAL	FLAT, METAL	N/A	NO	STORAGE	LOCKS BY OWNER	1	A	
330	OFFICE-JENNIFER	3'-0"	6'-8"	1- 3/4"	HOLLOW METAL	METAL	FLAT, METAL	N/A	NO	ENTRANCE	LOCKS BY OWNER	1	A	
331	COMPUTER AREA	3'-0"	6'-8"	1- 3/4"	HOLLOW METAL	METAL	FLAT, METAL	N/A	NO	ENTRANCE	LOCKS BY OWNER	1	A	

NOTES:
1. CONTRACTOR SHALL PROVIDE DOOR, FRAME, HINGES, DOOR STOP, GASKETING, AND STRIKE. LOCKS, LATCHES AND KEYS FURNISHED AND INSTALLED BY OWNER.

ROOM		ROOM FINISH SCHEDULE - REFER TO SHEET A1						
NO.	TYPE	CEILING HEIGHT	FLOORS	BASE	WALLS	DOORS AND FRAMES	REMARKS	
300A	CORRIDOR	8'-6" AFF	SEALED CONCRETE	VINYL-BLACK	5/8" GYPSUM BOARD-PAINT	PAINT - BY OWNER	5/8" TYPE "X" SHEET ROCK ON METAL STUDS WITH INSULATION TO DECK.	
323	IT STOR.	8'-6" AFF	SEALED CONCRETE	VINYL-BLACK	5/8" GYPSUM BOARD-PAINT	PAINT - BY OWNER	5/8" TYPE "X" SHEET ROCK ON METAL STUDS WITH INSULATION TO DECK.	
324	OFFICE-MATHEW	8'-6" AFF	SEALED CONCRETE	VINYL-BLACK	5/8" GYPSUM BOARD-PAINT	PAINT - BY OWNER	5/8" TYPE "X" SHEET ROCK ON METAL STUDS WITH INSULATION TO DECK.	
325	OFFICE-SPARE	8'-6" AFF	SEALED CONCRETE	VINYL-BLACK	5/8" GYPSUM BOARD-PAINT	PAINT - BY OWNER	5/8" TYPE "X" SHEET ROCK ON METAL STUDS WITH INSULATION TO DECK.	
326	OFFICE-TRISHA	8'-6" AFF	SEALED CONCRETE	VINYL-BLACK	5/8" GYPSUM BOARD-PAINT	PAINT - BY OWNER	5/8" TYPE "X" SHEET ROCK ON METAL STUDS WITH INSULATION TO DECK.	
327	COPY ROOM	8'-6" AFF	SEALED CONCRETE	VINYL-BLACK	5/8" GYPSUM BOARD-PAINT	PAINT - BY OWNER	5/8" TYPE "X" SHEET ROCK ON METAL STUDS WITH INSULATION TO DECK.	
328	OFFICE-KEITH	8'-6" AFF	SEALED CONCRETE	VINYL-BLACK	5/8" GYPSUM BOARD-PAINT	PAINT - BY OWNER	5/8" TYPE "X" SHEET ROCK ON METAL STUDS WITH INSULATION TO DECK.	
329	ARCHIVE STORAGE	8'-6" AFF	SEALED CONCRETE	VINYL-BLACK	5/8" GYPSUM BOARD-PAINT	PAINT - BY OWNER	5/8" TYPE "X" SHEET ROCK ON METAL STUDS WITH INSULATION TO DECK.	
330	OFFICE-JENNIFER	8'-6" AFF	SEALED CONCRETE	VINYL-BLACK	5/8" GYPSUM BOARD-PAINT	PAINT - BY OWNER	5/8" TYPE "X" SHEET ROCK ON METAL STUDS WITH INSULATION TO DECK.	
331	COMPUTER AREA	8'-6" AFF	SEALED CONCRETE	VINYL-BLACK	5/8" GYPSUM BOARD-PAINT	PAINT - BY OWNER	5/8" TYPE "X" SHEET ROCK ON METAL STUDS WITH INSULATION TO DECK.	
WALLS		PAINT PROVIDED BY OWNER INSTALLED BY OWNER.						
TRIM		PAINT PROVIDED BY OWNER INSTALLED BY OWNER.						
DOORS		PAINT PROVIDED BY OWNER INSTALLED BY OWNER.						
LOCKS		PROVIDED AND INSTALLED BY OWNER.						
FLOORS		SEALED TWO (2) COATS. PROVIDED BY OWNER INSTALLED BY OWNER.						
BASE		JOHNSONITE - VINYL BASE, BLACK MOLDED OUTSIDE CORNERS.						
CEILING		ARMSTRONG - #1728, NON-DIRECTIONAL, 5/8", WHITE TILE (MOISTURE AD SAG RESISTANT).						

GENERAL NOTES		
NO.	REVISIONS:	DATE:

**NEW IBERIA RESEARCH CENTER
BUILDING 30 - 3RD FLOOR RENOVATION FOR (IT)**

UL FACILITY MANAGEMENT
THE UNIVERSITY OF LOUISIANA AT LAFAYETTE
P.O. BOX 43646
LAFAYETTE, LOUISIANA 70504



PROJECT NO:	SHEET:
DATE: SEPT. 2023	A3
SCALE: 1" = 0"	

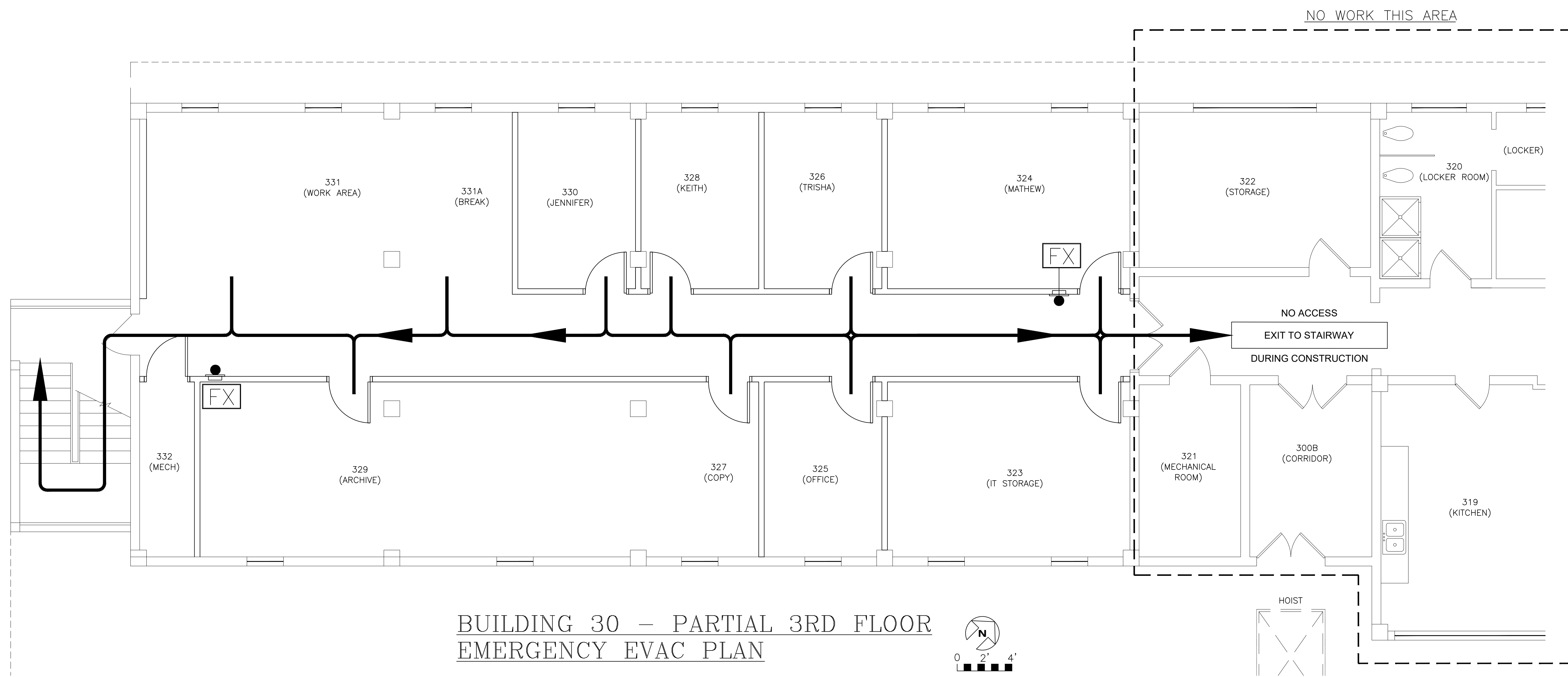

BUILDING 30 – PARTIAL 3RD FLOOR
EMERGENCY EVAC PLAN

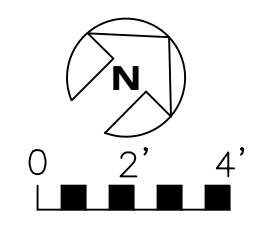

EMERGENCY LEGEND

ESCAPE ROUTE
 FIRE EXTINGUISHER
 AREA OF RESCUE ASSISTANCE
 EVACUATION ASSEMBLY AREA AT WEST END OF BUILDING ADJACENT TO ROADWAY

GENERAL NOTES		
NO:	REVISIONS:	DATE:

NEW IBERIA RESEARCH CENTER
BUILDING 30 - 3RD FLOOR RENOVATION FOR (IT)

UL FACILITY MANAGEMENT
 THE UNIVERSITY OF LOUISIANA AT LAFAYETTE
 P.O. BOX 43646
 LAFAYETTE, LOUISIANA 70504

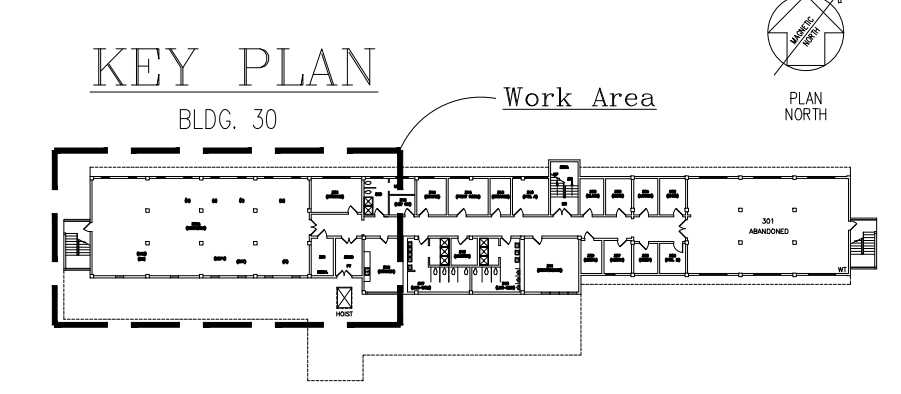

PROJECT NO:	SHEET:
DATE: SEPT. 2023	A4
SCALE: 1" = 0"	

DOOR SCHEDULES AND ROOM FINISHES

NIRC – BUILDING 30 – 3RD FLOOR RENOVATION FOR IT-ARCH

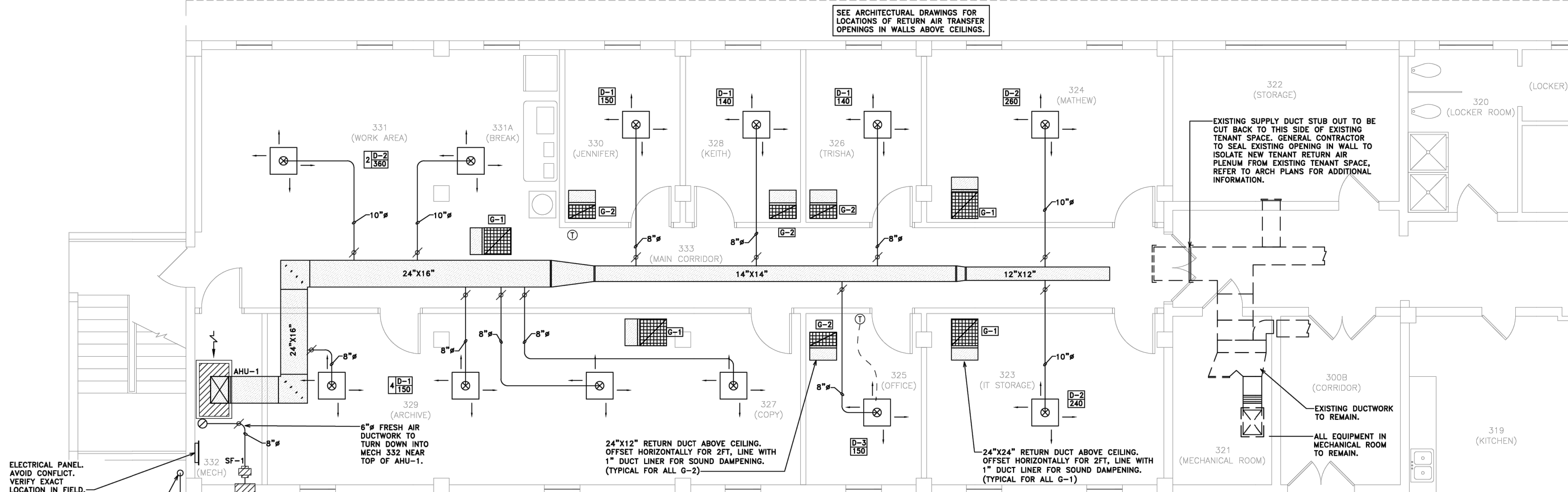

ELECTRICAL PANEL. AVOID CONFLICT. VERIFY EXACT LOCATION IN FIELD.

REFRIGERANT AND CONDENSATE DRAIN PIPING TO FOLLOW SIMILAR ROUTING. PIPING TO BE STRAPPED TO EXISTING WALL. COORDINATE EXACT ROUTING IN FIELD. RISE UP ON EXTERIOR WALL AT MECH 332.

ELECTRICAL PANEL. AVOID CONFLICT. VERIFY EXACT LOCATION IN FIELD.

PROVIDE FRENCH DRAIN FOR CONDENSATE. COORDINATE EXACT LOCATION WITH OWNER AND GENERAL CONTRACTOR. SEE DETAIL ON THIS PAGE.

BUILDING 30 - PARTIAL 3RD FLOOR MECHANICAL PLAN

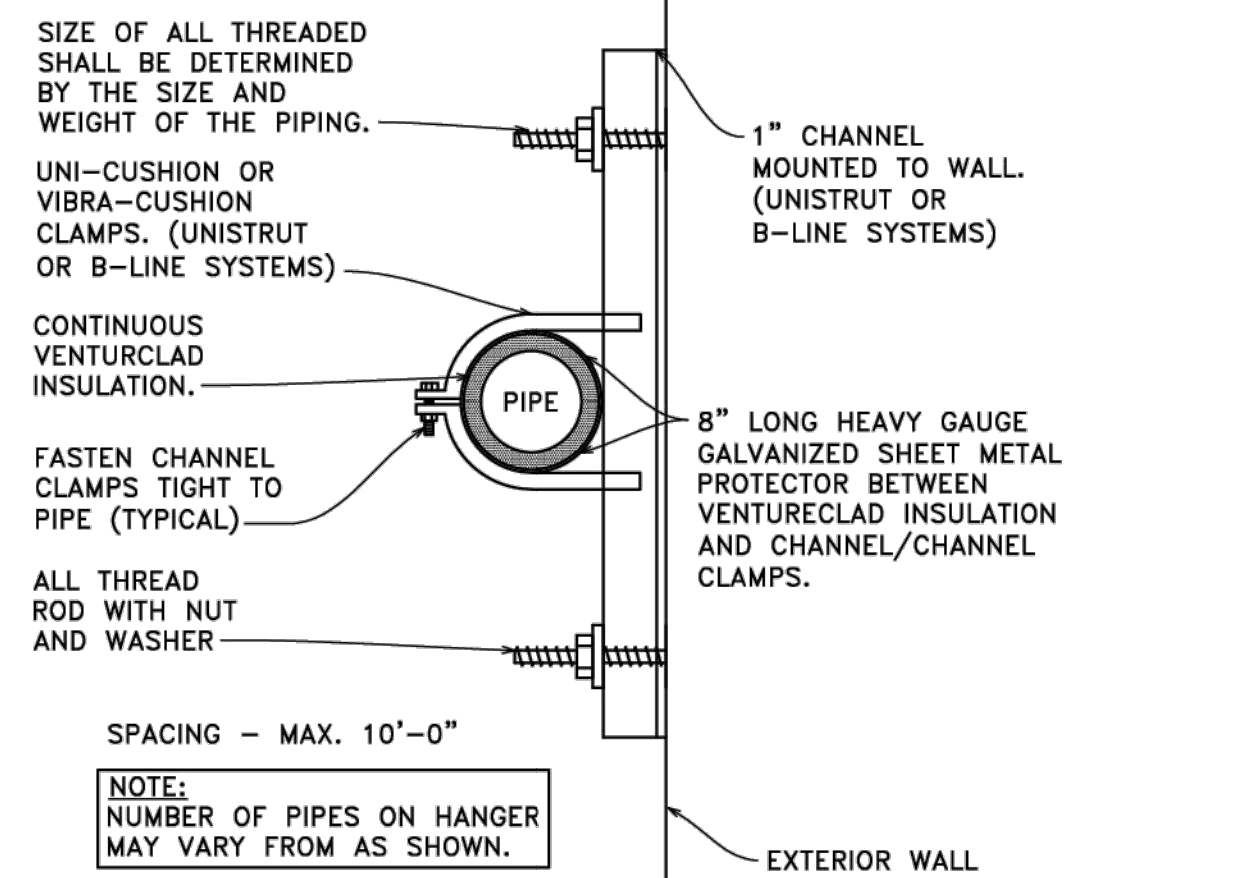
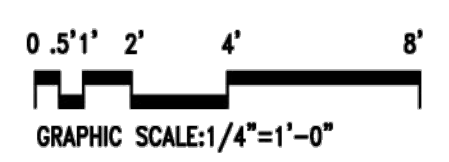

EXTERIOR PIPING ON WALL DETAIL

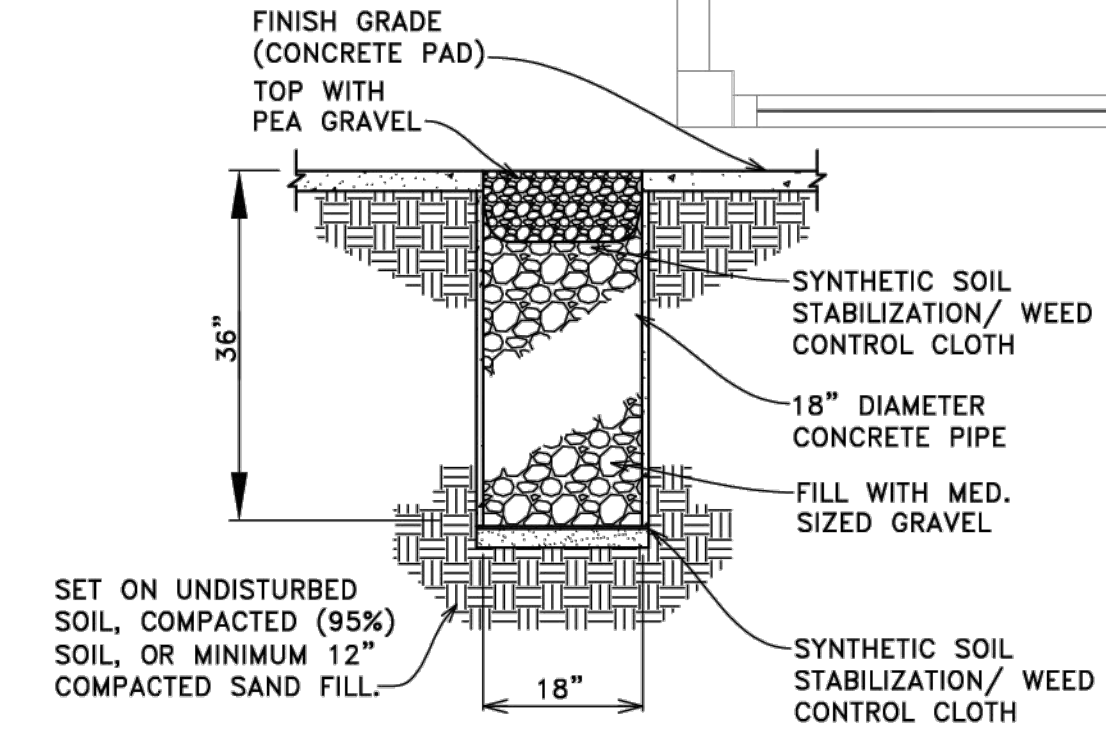

FRENCH DRAIN DETAIL

MECHANICAL GENERAL NOTES:

- THE FOLLOWING IS A BRIEF DESCRIPTION OF WORK SPECIFIC TO CERTAIN ASPECTS OF THIS PROJECT. THIS IS NOT INTENDED TO BE A COMPREHENSIVE SUMMARY OF WORK. PROSPECTIVE BIDDERS/CONTRACTORS SHALL REVIEW ALL CONSTRUCTION DRAWINGS, SPECIFICATIONS AND SITE CONDITIONS AND MAKE ALLOWANCES FOR ALL WORK INCLUDED HEREIN AND ANY ADDITIONAL WORK REQUIRED TO COMPLETE THIS PROJECT. MEANS AND METHODS FOR THE PROPER INSTALLATION OF THIS WORK IS STRICTLY THE RESPONSIBILITY OF THE GENERAL CONTRACTOR AND HIS SUB-CONTRACTORS.
- MECHANICAL CONTRACTOR SHALL BE RESPONSIBLE FOR COORDINATING THE ROUTING OF ALL DUCTWORK WITH THE STRUCTURE AND OTHER TRADES AS CONDITIONS ALLOW. RE-ROUTE DUCTWORK AS NECESSARY TO AVOID CONFLICT. TRANSITION UP/DOWN TO AVOID OTHER TRADES AS NECESSARY.
 - INSTALL AT EACH DUCT TAKEOFF AN ADJUSTABLE VOLUME DAMPER IN AN ACCESSIBLE LOCATION.
 - PROVIDE METAL STRAP HANGERS FOR ALL DUCTWORK AT MINIMUM 8 FT. INTERVALS.
 - CONTRACTOR SHALL COORDINATE SPACE REQUIREMENTS AND SERVICE CLEARANCES FOR ALL EQUIPMENT PRIOR TO SUBMITTING SHOP DRAWINGS. NO EQUIPMENT SHALL BE BID ON (WHETHER OR NOT RECEIVING PRIOR APPROVAL) IF IT DOES NOT FIT IN SPACE PROVIDED.
 - MECHANICAL CONTRACTOR SHALL PROCURE THE SERVICES OF AN INDEPENDENT AABC, TABB OR NEBB CERTIFIED TEST AND BALANCE AGENCY. TAB AGENCY SHALL PERFORM AN INITIAL SMOKE/PRESSURE LEAK TEST ON ALL DUCTWORK ONCE ALL SHEETMETAL DUCTWORK HAS BEEN INSTALLED. A FINAL BALANCE REPORT OF ALL HVAC SYSTEMS (INCLUDING SUPPLY/RETURN TRAVERSES) AND EXHAUST FANS SHALL BE PROVIDED TO ARCHITECT/ENGINEER UPON COMPLETION OF PROJECT. ALL REPORTS SHALL MEET AABC/NEBB STANDARDS. REFER TO SPECIFICATIONS FOR COMPLETE TEST AND BALANCE REQUIREMENTS.
 - WHERE DUCTS ARE CROSSING EACH OTHER, CONTRACTOR SHALL ASSUME AN UPWARD AND DOWNWARD TRANSITION AS REQUIRED BETWEEN STRUCTURAL MEMBERS AS REQUIRED FOR AVAILABLE CEILING SPACE. NO EXTRA WILL BE GIVEN FOR THESE TRANSITIONS.

- CONTRACTOR SHALL COORDINATE THE LOCATION OF ALL DEVICES (THERMOSTATS, SENSORS, ETC.) WITH THE ARCHITECT AND OWNER PRIOR TO INSTALLATION. MOUNT EACH THERMOSTAT AT A HEIGHT OF 48" AFF TO CENTER LINE OF CONTROLLER. PROVIDE LOCK BOXES WHERE REQUIRED BY OWNER. THERMOSTATS SHALL BE PROGRAMMABLE AND SHALL HAVE TEMPERATURE AND HUMIDITY SETPOINT ADJUSTMENT. TEMPERATURE CONTROLS CONTRACTOR SHALL SUBMIT THERMOSTAT/SENSOR LOCATION PLAN PRIOR TO ROUGH-IN. CONTROLS CONTRACTOR SHALL BE RESPONSIBLE FOR ALL 24V AND 120V CONTROL POWER INCLUDING CONTROL PANELS. COORDINATE WITH ELECTRICAL CONTRACTOR FOR LOCATION OF NEAREST AVAILABLE CIRCUIT FROM WHICH TO TAP CONTROL POWER.
- ALL EQUIPMENT, DAMPERS, ETC. LOCATED ABOVE CEILING SHALL BE INSTALLED AT A HEIGHT ACCESSIBLE FOR BALANCING AND/OR SERVICE.
- COORDINATE THE EXACT PLACEMENT OF ALL CEILING MOUNTED DIFFUSERS AND GRILLES WITH THE CEILING, LIGHTS AND ANY OTHER CEILING MOUNTED EQUIPMENT.
- TRANSITION SUPPLY AND RETURN DUCTWORK TO FANS AND AIR HANDLING UNITS WITH SMOOTH TRANSITIONS PER SMACNA STANDARDS AS NECESSARY. DUCTWORK CONNECTIONS TO EQUIPMENT SHALL BE MADE WITH FLEXIBLE CONNECTIONS.
- COORDINATE FRESH AIR INLETS WITH EXHAUST OUTLETS AND PLUMBING VENTS TO MAINTAIN A 10'-0" MINIMUM SEPARATION.
- FURNISH AND INSTALL ACCESS PANELS WHERE VALVES, DAMPERS, EQUIPMENT, ETC ARE CONCEALED OR INACCESSIBLE. ACCESS PANELS SHALL BE PRIMED AND PAINTED COLOR AS SELECTED BY ARCHITECT.
- PROVIDE ONE SET OF CLEAN FILTERS AT COMPLETION OF PROJECT PRIOR TO TURNING OVER TO OWNER. CONSTRUCTION FILTERS SHALL BE USED DURING DURATION OF PROJECT TO PROTECT DUCTWORK AND EQUIPMENT. DO NOT OPERATE EQUIPMENT UNLESS BUILDING HAS BEEN THOROUGHLY CLEANED.
- ALL DUCTWORK DIMENSIONS ARE METAL TO METAL, UNLESS OTHERWISE NOTED.
- ALL PENETRATIONS THROUGH RATED ASSEMBLIES SHALL BE FIRE CAULKED TO MAINTAIN UL LISTING. DUCTS PENETRATING RATED ASSEMBLIES SHALL BE FURNISHED WITH FIRE DAMPERS.

NOTE: THE CONTRACTOR MAY SCALE THESE DRAWINGS. HOWEVER, THE CONTRACTOR SHALL BE RESPONSIBLE FOR VERIFICATION OF ALL DIMENSIONS, PLAN SCALE, AND SITE CONDITIONS BEFORE BIDDING AND DURING CONSTRUCTION.

RITTER CONSULTING ENGINEERS 2014 W. PINHOOK RD SUITE 200 LAFAYETTE, LOUISIANA 70508 (337) 984-8498 FAX (337) 984-8578

RICE PROJECT NO. 230015

USE AND INTERPRETATION OF THIS DRAWING

1. GENERAL CONDITIONS OF THE CONTRACT FOR CONSTRUCTION, ARTICLE 1 AND DOCUMENT A-1, ARE PART OF THE CONTRACT DOCUMENTS AND DESCRIBE THE USE AND INTENT OF THIS DRAWING. THE CONTRACT DOCUMENTS INCLUDE NOT ONLY THE DRAWINGS BUT ALSO THE OWNER/CONTRACTOR AGREEMENT, CONDITIONS OF THE CONTRACT, THE SPECIFICATIONS, ADDENDA, AND MODIFICATIONS ISSUED AFTER EXECUTION OF THE CONTRACT. THESE CONTRACT DOCUMENTS ARE COMPLEMENTARY AND WHAT IS REQUIRED BY ANYONE SHALL BE AS BINDING AS IF REQUIRED BY ALL WORK NOT COMPLETELY DELINEATED HEREON SHALL BE CONSTRUCTED OF THE SAME MATERIALS AND DETAILED SIMILARLY AS WORK SHOWN MORE COMPLETELY ELSEWHERE IN THE CONTRACT DOCUMENTS.

2. BY USE OF THE DRAWINGS FOR CONSTRUCTION OF THE PROJECT, THE OWNER REPRESENTS THAT HE HAS REVIEWED AND APPROVED THE DRAWINGS AND THAT THE CONSTRUCTION DOCUMENTS PHASE OF THE PROJECT IS COMPLETE. THE CONTRACTOR REPRESENTS THAT HE HAS VISITED THE SITE, FAMILIARIZED HIMSELF WITH THE LOCAL CONDITIONS, VERIFIED FIELD DIMENSIONS AND CORRELATED HIS OBSERVATIONS WITH REQUIREMENTS OF THE CONTRACT DOCUMENTS.

3. THE CONTRACT BIDDING AND CONTRACT TIME MAY BE CHANGED ONLY BY CHANGE ORDER TO THE CONTRACTOR SIGNED BY THE OWNER AND THE ARCHITECT. ANY WORK PERFORMED IN VIOLATION WITH THE CONTRACT DOCUMENTS AND NOT COVERED BY THE ARCHITECT'S WRITTEN ORDER FOR A MINOR CHANGE IN THE WORK OR A CHANGE ORDER, SHALL NOT BE ACCEPTED.

4. AS INSTRUMENTS OF SERVICE, ALL DRAWINGS, SPECIFICATIONS AND COPIES THEREOF FURNISHED BY THE ARCHITECT ARE HIS PROPERTY. THEY ARE TO BE USED ONLY FOR THIS PROJECT AND ARE NOT TO BE USED ON ANY OTHER PROJECT. CHANGES TO THE DRAWINGS MAY ONLY BE MADE BY THE ARCHITECT. ANY SUBMISSION OR CONSTRUCTION WITHOUT THE EXPRESS WRITTEN CONSENT OF THE ARCHITECT MAY BE CONSIDERED AS DEROGATION OF THE ARCHITECT'S COPYRIGHT OR OTHER RESERVED RIGHTS.

REUSE OF THIS DRAWING IN ANY MANNER IS STRICTLY PROHIBITED WITHOUT THE WRITTEN APPROVAL OF RITTER CONSULTING ENGINEERS, LTD.

STATE OF LOUISIANA
ANDREA B. MANCEAUX
License No. 39890
PROFESSIONAL ENGINEER
IN
MECHANICAL ENGINEERING
9/15/22

GENERAL NOTES		
NO.	REVISIONS	DATE

NEW IBERIA RESEARCH CENTER BUILDING 30 - 3RD FLOOR RENOVATION FOR (IT)

UL FACILITY MANAGEMENT
THE UNIVERSITY OF LOUISIANA AT LAFAYETTE
P.O. BOX 43846
LAFAYETTE, LOUISIANA 70504

UL
UNIVERSITY OF LOUISIANA AT LAFAYETTE
FACILITY MANAGEMENT

PROJECT NO: SHEET:
DATE: MAY 2023
SCALE: AS NOTED
M1

HEAT PUMP SCHEDULE (SPLIT SYSTEM)

INDOOR SECTION																	OUTDOOR SECTION (HEAT PUMP)							REMARKS		
FAN							COOLING				HEATING			AUXILIARY HEATING			MARK	MIN. BTUH CLG. OUTPUT	MIN. BTUH HTG. OUTPUT	TONNAGE	UNIT MCA	UNIT MOC	ELECTRIC SERVICE			
MARK	SERVICE	CFM	CFM F.A.	EXT. S.P.	FAN H.P.	ELECTRICAL SERVICE	NOMINAL BTUH	ENT. AIR TEMP.		TONNAGE	AMB. TEMP (°F)	MIN BTUH OUTPUT @ 47 (°F)	ENT AIR (°F)	LEAV. AIR (°F)	MIN BTUH AUXILIARY STRIP OUTPUT	KW ELEC. STRIP									ELECTRIC SERVICE	
								DB (°F)	WB (°F)						MIN.	MAX.										
AHU-1	SEE PLANS	2400	100	.45	2	208-3-60	72,000	75.84	63.38	6	95	67,000	70	95	64,800	19	22	208-3-60	HP-1	72,000	67,000	6	26	35	208-3-60	TRANE 6 TON HEAT PUMP WITH 2 SPEED VFD AIR HANDLER.

HEAT PUMP NOTES:

- ALL UNITS SHALL BE INSTALLED WITH RUBBER VIBRATION ISOLATION PADS UNDER UNIT.
- PROVIDE WITH HIGH/LOW PRESSURE SWITCH, LOW AMBIENT KIT, TIME DELAY AND SUCTION LINE ACCUMULATOR.
- COORDINATE ELECTRICAL SERVICE WITH ELECTRICAL CONTRACTOR PRIOR TO ORDERING EQUIPMENT.
- THE MANUFACTURER SHALL SIZE THE REFRIGERANT LINES FOR THE LENGTH AND CONDITIONS OF THE PROJECT.

AIR HANDLER NOTES:

- FURNISH AIR HANDLER WITH PROGRAMMABLE THERMISTAT (TEMPERATURE AND HUMIDITY SETPOINTS).
- ALL AIR HANDLERS SHALL REQUIRE SINGLE POINT POWER CONNECTION. COORDINATE ELECTRICAL SERVICE WITH ELECTRICAL CONTRACTOR PRIOR TO ORDERING EQUIPMENT.
- CONTRACTOR SHALL FURNISH TWO SETS OF MERV 8 FILTERS FOR EACH AIR HANDLING UNIT FOR USE DURING CONSTRUCTION AND TWO SETS OF MERV 8 FILTERS TO OWNER AT SUBSTANTIAL COMPLETION AS SPECIFIED.
- INDOOR UNIT SHALL BE FURNISHED WITH GPS/PLASMA AIR NEEDLEPOINT BIPOLAR IONIZATION, INTERLOCK WITH UNIT INCOMING POWER. LOCATE UPSTREAM OF COIL.
- PROVIDE AND INSTALL UNIT WITH 20 GAUGE GALV. SHEET METAL EMERGENCY DRAIN PAN, LIQUID TIGHT AND INSIDE COATED WITH 1/16" THICK COATING OF BITUMINOUS BASE MASTIC. PAN SHALL BE 4 INCH HIGH AND EXTEND BEYOND PERIMETER OF UNIT. PROVIDE AND INSTALL WITH FLOAT SWITCH WIRED FOR UNIT SHUT DOWN. EXTEND DRAIN LINE TO EXTERIOR, TERMINATE 6" AFG (VALVE CLOSED AT PAN).

GRILLE & LOUVER SCHEDULE

SYMBOL	SIZE	SERVICE	LOCATION	CONSTRUCTION MATERIAL	FINISH	REMARKS
G-1	24"x24"	RETURN/TRANSFER	CEILING	ALUMINUM	WHITE	TITUS 50F, PRICE, NAILOR OR EQUAL
G-2	12"x24"	RETURN/TRANSFER	CEILING	ALUMINUM	WHITE	TITUS 50F, PRICE, NAILOR OR EQUAL
L-1	12"x12"	EXHAUST	EXTERIOR WALL	ALUMINUM	KYNAR	GREENHECK EHV-901 OR EQUAL AMCA 540 & 550 LISTED LOUVER

NOTES:

- TRANSITION DUCTWORK TO FULL FACE OF GRILLE.
- KYNAR FINISH TO BE SELECTED BY ARCHITECT FROM MANUFACTURERS STANDARD AND CUSTOM COLOR CHARTS.

CEILING DIFFUSER SCHEDULE

MARK	DIFFUSER SIZE	NECK SIZE	CFM RANGE	CONSTRUCTION MATERIAL	FINISH	REMARKS
D-1	24"x24"	8"Ø	100-200	ALUMINUM	WHITE	TITUS TDC, PRICE, NAILOR, OR EQUAL
D-2	24"x24"	10"Ø	205-300	ALUMINUM	WHITE	TITUS TDC, PRICE, NAILOR, OR EQUAL
D-3	24"x24"	6"Ø	130-210	ALUMINUM	WHITE	TITUS T3SQM, PRICE PPD, OR EQUAL VAV DIFFUSER

NOTES:

- D-1 & D-2 SHALL BE FURNISHED WITH OPPOSED BLADE DAMPERS.
- BACK SIDE OF DIFFUSER SHALL BE INSULATED SAME AS DUCTWORK.

FAN SCHEDULE

NO.	SERVICE	CFM	EXT. S.P.	MAX RPM	FAN HP	TYPE	DRIVE	ELECTRICAL SERVICE	REMARKS
SF-1	OUTSIDE AIR	100	0.2	2412	1 / 5	CENT	DIRECT	120-1-60	FANTECH FG6 CENTRIFUGAL INLINE FAN OR EQUAL

NOTES:

- DIRECT DRIVE FANS SHALL BE FURNISHED WITH SPEED CONTROL SWITCH, MOUNTED AT THE FAN FOR BALANCING.
- SF-1 TO BE INTERLOCKED WITH ASSOCIATED HEAT PUMP COMPRESSOR OPERATION. PROVIDE MOTORIZED DAMPER IN FRESH AIR DUCT. FRESH AIR DAMPER SHALL OPEN ONLY DURING FAN OPERATION.

MECHANICAL SCHEDULES

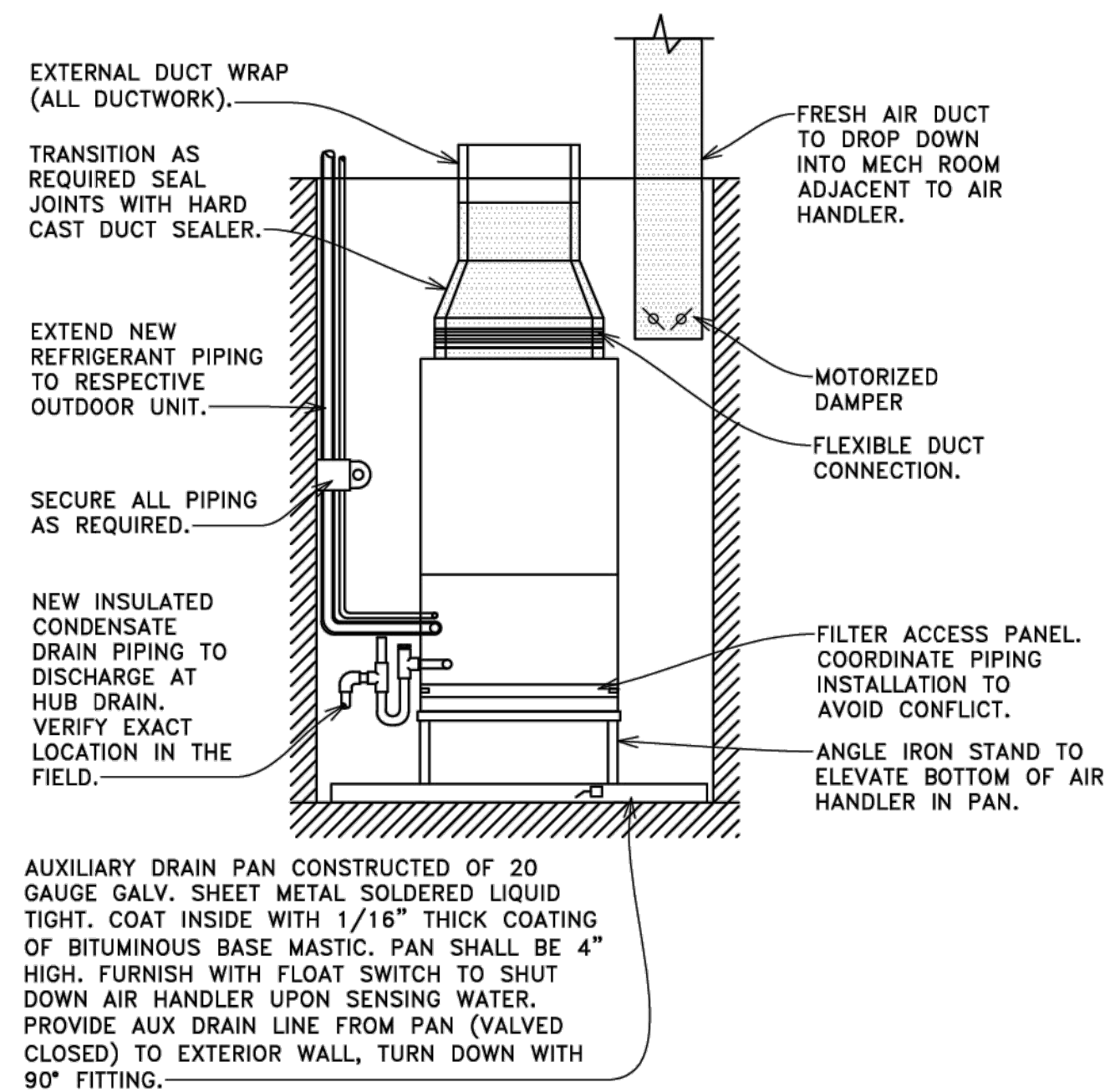

AIR HANDLER IN CLOSET DETAIL

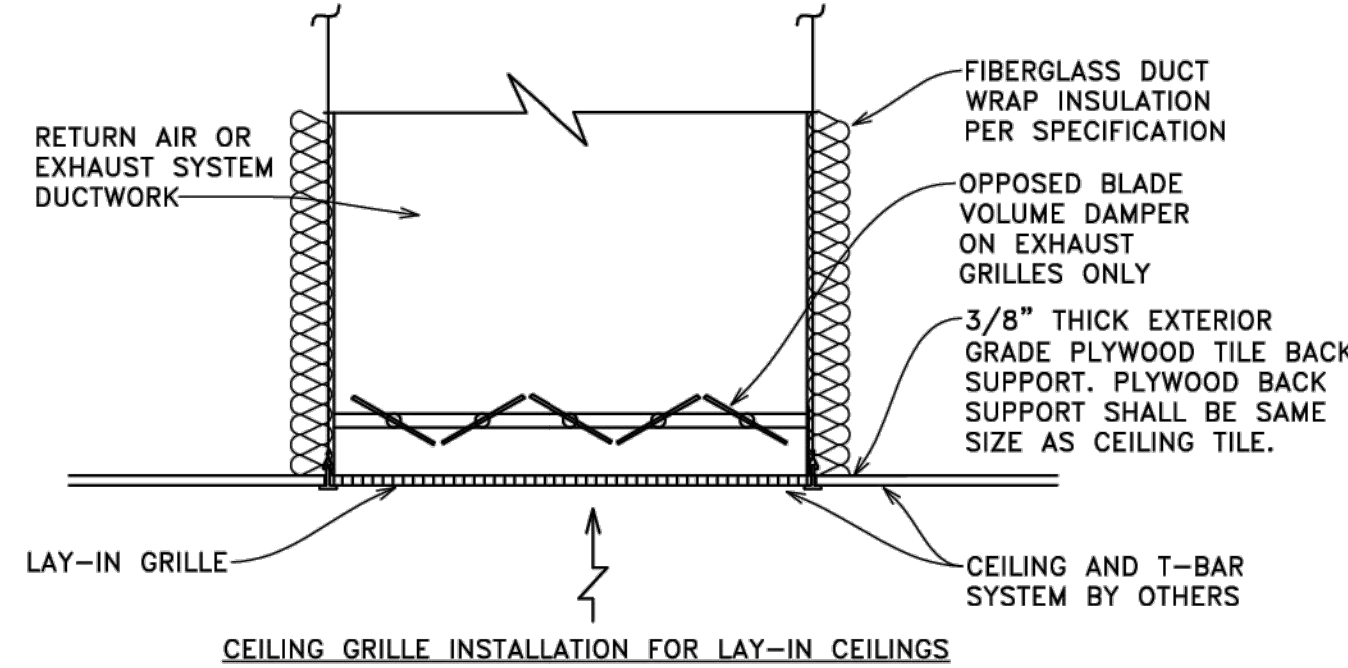

GRILLE INSTALLATION DETAIL

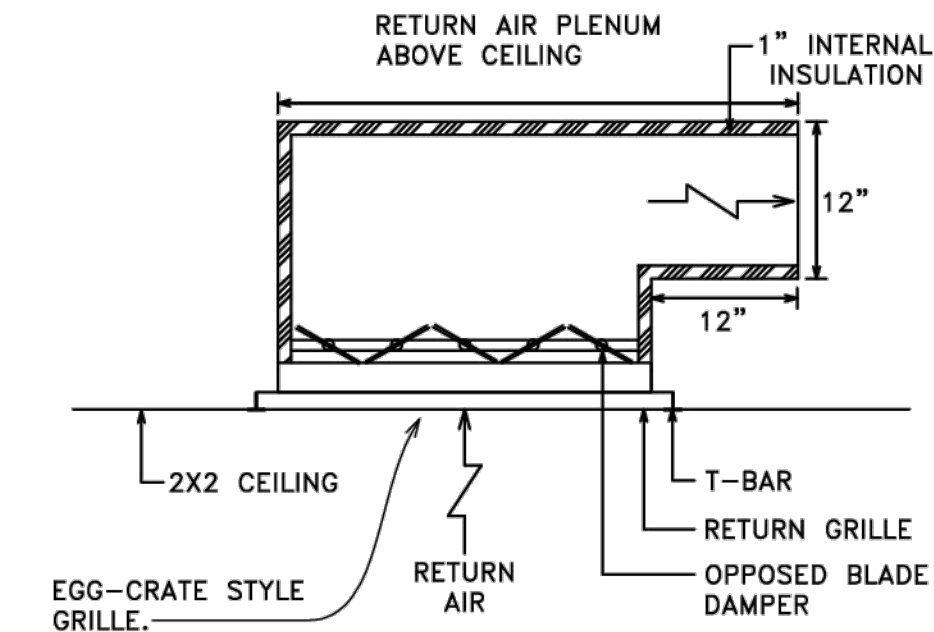

TRANSFER GRILLE DETAIL

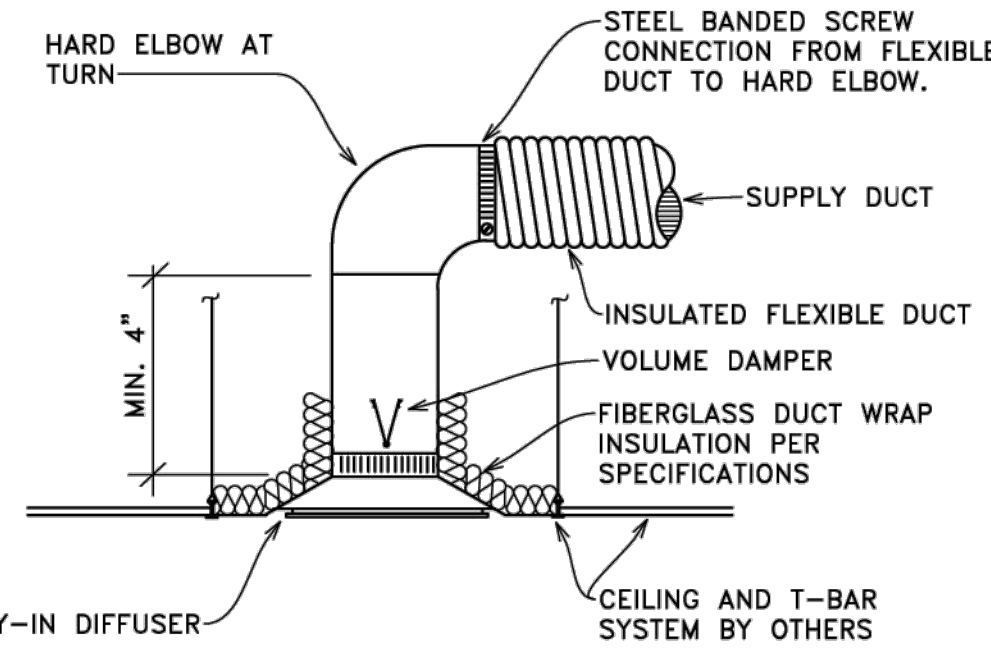

DIFFUSER INSTALLATION DETAIL

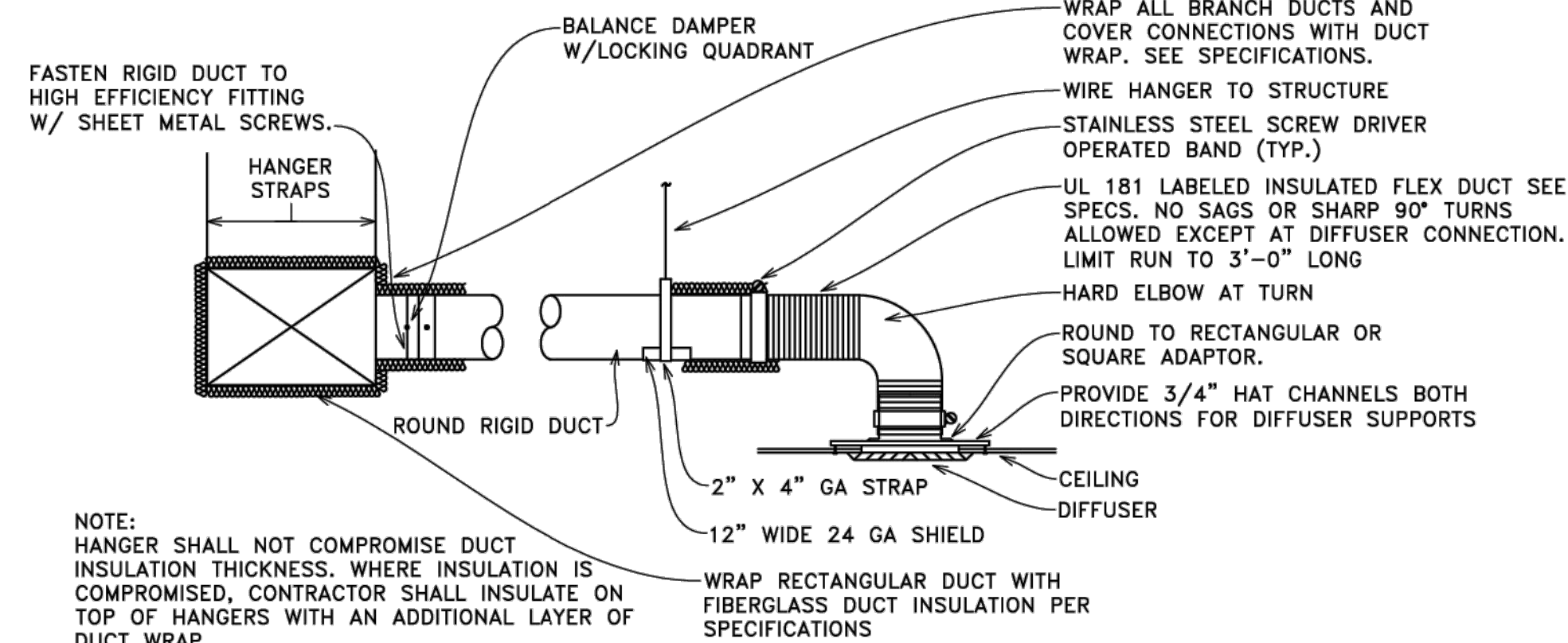

TYPICAL DIFFUSER CONNECTION DETAIL

DIFFUSER INSTALLATION DETAIL

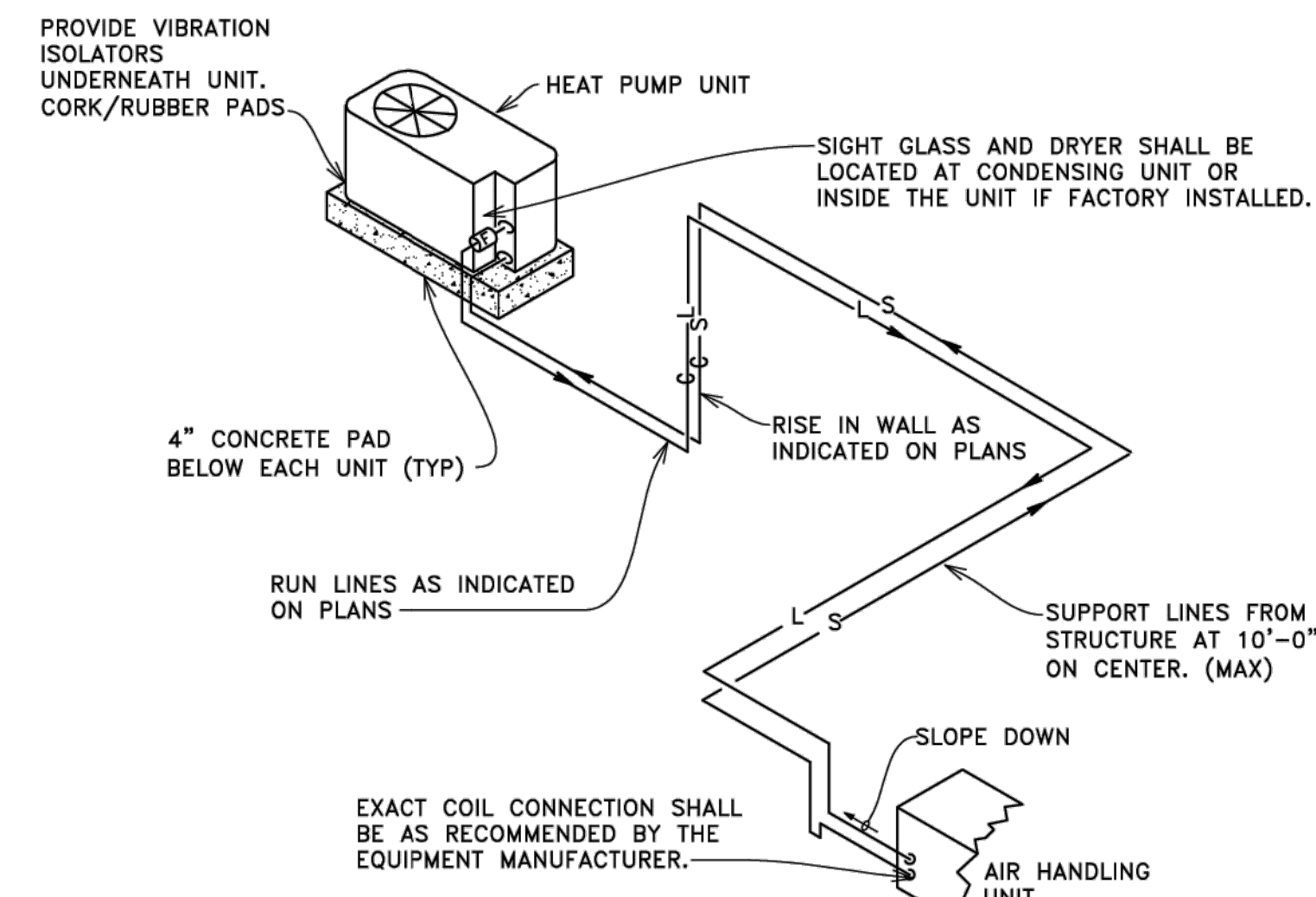

HEAT PUMP REFRIGERANT PIPING DETAIL

GENERAL NOTES		
NO.	REVISIONS	DATE:

NEW IBERIA RESEARCH CENTER BUILDING 30 - 3RD FLOOR RENOVATION FOR (IT)

UL FACILITY MANAGEMENT
THE UNIVERSITY OF LOUISIANA AT LAFAYETTE
P.O. BOX 43646
LAFAYETTE, LOUISIANA 70504

RITTER CONSULTING ENGINEERS
2014 W. PINHOOK RD SUITE 200
LAFAYETTE, LOUISIANA 70506
(337) 984-8498 FAX (337) 984-8578

RCE PROJECT NO. 230015
USE AND INTERPRETATION OF THIS DRAWING
1. GENERAL CONDITIONS OF THE CONTRACT FOR CONSTRUCTION, ARTICLE 1 AND DOCUMENTS AS PART OF THE CONTRACT DOCUMENTS AND DESCRIBE USE AND INTENT OF THIS DRAWING. THE CONTRACTOR SHALL BE RESPONSIBLE FOR VERIFYING ALL DIMENSIONS, PLAN SCALE, AND SITE CONDITIONS BEFORE BIDDING AND DURING CONSTRUCTION.
2. BY USE OF THIS DRAWING FOR CONSTRUCTION OF THE PROJECT, THE OWNER REPRESENTS THAT HE HAS REVIEWED AND APPROVED THE DRAWINGS AND THAT THE CONSTRUCTION DOCUMENTS PHASE OF THE PROJECT IS COMPLETE. THE CONTRACTOR REPRESENTS THAT HE HAS VISITED THE SITE, FAMILIARIZED HIMSELF WITH THE LOCAL CONDITIONS, VERIFIED FIELD DIMENSIONS AND CORRELATED HIS OBSERVATIONS WITH REQUIREMENTS OF THE CONTRACT DOCUMENTS.
3. THE CONTRACT SUM AND CONTRACT TIME MAY BE CHANGED ONLY BY CHANGE ORDER TO THE CONTRACTOR ISSUED BY THE OWNER AND THE ARCHITECT. ANY WORK PERFORMED IN VIOLATION WITH THE CONTRACT DOCUMENTS AND NOT COVERED BY THE ARCHITECT'S WRITTEN ORDER FOR A MINOR CHANGE IN THE WORK OR A CHANGE ORDER, WILL NOT BE ACCEPTED.
4. ALL INSTRUMENTS OF SERVICE, ALL DRAWINGS, SPECIFICATIONS AND COPIES THEREOF FURNISHED BY THE ARCHITECT ARE HIS PROPERTY. THEY ARE TO BE USED ONLY FOR THIS PROJECT AND ARE NOT TO BE USED ON ANY OTHER PROJECT. CHANGES TO THE DRAWINGS MAY ONLY BE MADE BY THE ARCHITECT. ANY SUBMISSION OR DISTRIBUTION WITHOUT THE EXPRESS WRITTEN CONSENT OF THE ARCHITECT MAY BE CONSIDERED AS DEROGATION OF THE ARCHITECT'S COPYRIGHT OR OTHER RESERVED RIGHTS.
REUSE OF THIS DRAWING IN ANY MANNER IS STRICTLY PROHIBITED WITHOUT THE WRITTEN APPROVAL OF RITTER CONSULTING ENGINEERS, LTD.

STATE OF LOUISIANA
ANDREA B. MANCEAU
License No. 39890
PROFESSIONAL ENGINEER
IN
MECHANICAL ENGINEERING
5/15/15

UL
UNIVERSITY OF LOUISIANA AT LAFAYETTE
FACILITY MANAGEMENT

PROJECT NO: SHEET:
DATE: MAY 2023 M2
SCALE: AS NOTED

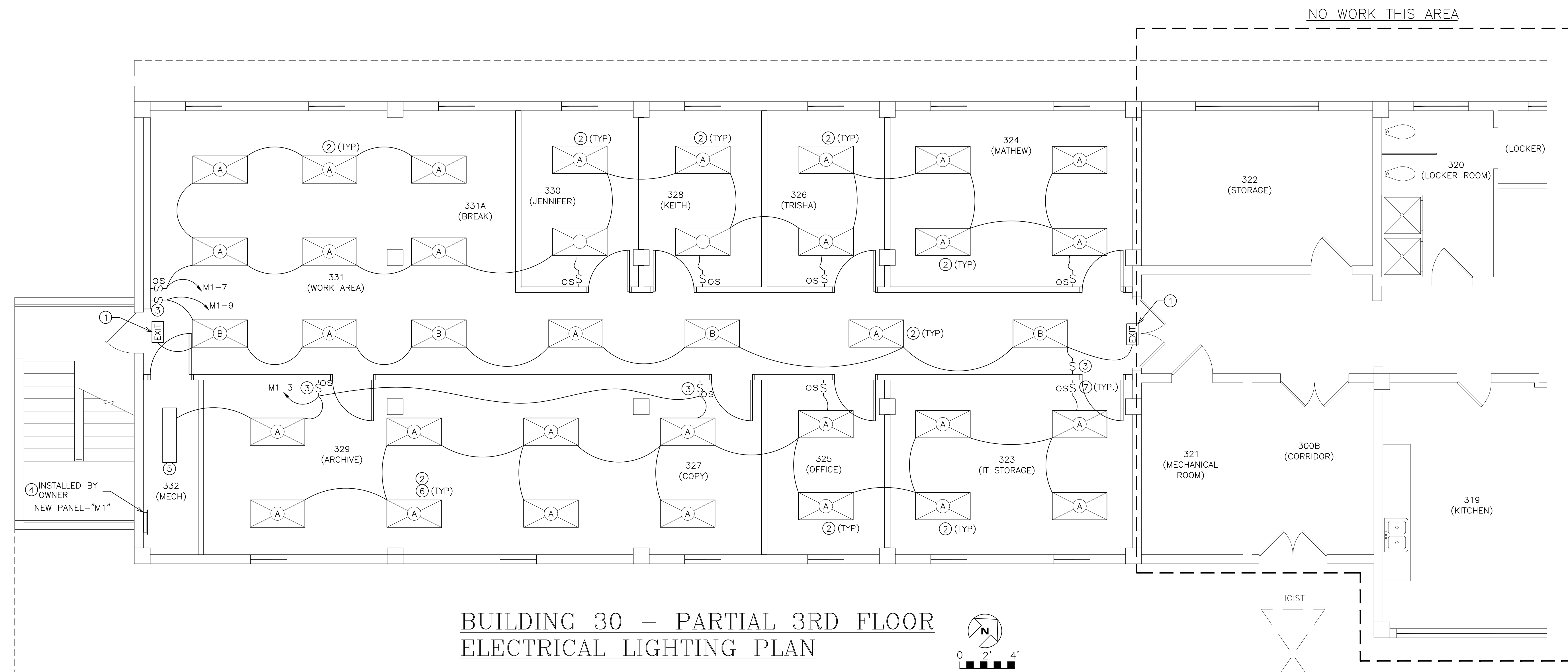

**BUILDING 30 – PARTIAL 3RD FLOOR
ELECTRICAL LIGHTING PLAN**

ELECTRICAL PLAN GENERAL NOTES:

- A. ALL FIXTURES ACCESSORIES NEEDED FOR PROPER INSTALLATION SHALL BE PROVIDED AND INSTALLED BY ELECTRICAL CONTRACTOR.
- B. EXACT PLACEMENT OF ALL INTERIOR LIGHTING FIXTURES TO BE COORDINATED WITH ARCHITECTURAL DRAWINGS PRIOR TO INSTALL.
- C. ANY FIXTURE AIMING SHALL BE AS PER ENGINEER IN FIELD.
- D. CONTRACTOR TO PROVIDE AND INSTALL ALL LOW VOLTAGE CONTROLS REQUIRED FOR DIMMING AND/OR OCCUPANCY SENSORS.
- E. RUN ALL CONDUIT AS AS REQUIRED. ALL CONDUIT SHALL BE ANCHORED TO ROOF STRUCTURE ABOVE. INSTALL "J" BOXES WHERE REQUIRED AND LABEL "J" BOXES WITH PANEL NAME AND CIRCUIT NUMBER FOR FUTURE IDENTIFICATION.
- F. ALL CONDUIT AND CABLING ABOVE CEILING SHALL BE PLENUM RATED.
- G. CONTRACTOR SHALL PROVIDE RIGID CONDUIT AT ALL EXPOSED LOCATIONS. CONTRACTOR SHALL PROVIDE RIGID CONDUIT FROM MAIN PANEL TO JUNCTION BOX SERVING LIGHTS. PLENUM RATED "MC" CONDUIT MAY BE UTILIZED TO CONNECT LIGHTING.

ELECTRICAL PLAN GENERAL NOTES:

- ① - INSTALL NEW LED EXIT LIGHTS WHERE SHOWN ON PLANS. CONNECT TO EXIT LIGHT CIRCUIT IN EXISTING PANEL "M1" IN ROOM 332.
- ② - CONNECT NEW LIGHT FIXTURES TO CIRCUITRY SHOWN FED FROM EXISTING PANEL "M1" IN ROOM 332. INSTALL NEW 20 AMP LIGHT SWITCHES AND WALL MOUNT OCCUPANCY SWITCHES WHERE SHOWN ON PLANS. CONNECT
- ③ - PROVIDE 3-WAY SWITCHING THIS AREA.
- ④ - OWNER SHALL PROVIDE AND INSTALL NEW 120V/208V/3PH/60HZ, 42 SLOT, NEMA-1, FLUSH MOUNTED PANEL. OWNER SHALL COORDINATE LOCATION OF NEW FLUSH MOUNTED ELECTRICAL PANEL WITH NEW FILING CABINETS.
- ⑤ - OWNER PROVIDED, CONTRACTOR INSTALLED SURFACE MOUNTED, LED LIGHT FIXTURE.
- ⑥ - REFER TO AND COORDINATE WITH REFLECTED CEILING PLANS FOR LIGHTING LOCATIONS.
- ⑦ - INSTALL OCCUPANCY SENSOR LIGHT SWITCHES AS INDICATED.

SYMBOL LEGEND:

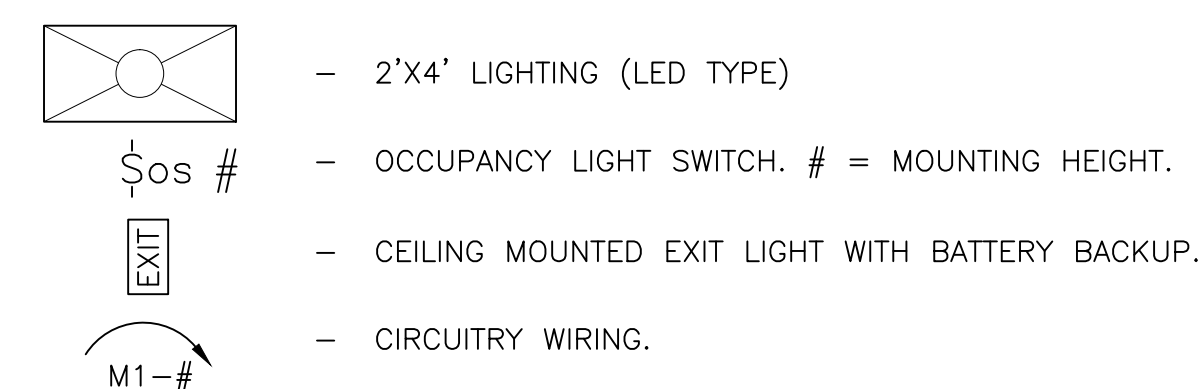

FIXTURE SCHEDULE					
FIXTURE TYPE	MANUFACTURER	CATALOG NUMBER	LAMP/WATTS	DESCRIPTION	REMARKS
A	LITHONIA	(2X4) 2SFL4 40L EZ1LP835	LED/39W	2'X4' FLAT PANEL	1,5
B	LITHONIA	(2X4) 2ESL4 40L EZ1 LP835 N100 EL 14L	LED/39W	2'X4' FLAT PANEL	1,5,6

REMARKS:

- 1. SET FIXTURE TO 4400LM OUTPUT PRIOR TO INSTALLATION.
- 2. SET FIXTURE TO 4000LM OUTPUT PRIOR TO INSTALLATION.
- 3. SET FIXTURE TO 3300LM OUTPUT PRIOR TO INSTALLATION.
- 4. SET FIXTURE TO 2400LM OUTPUT PRIOR TO INSTALLATION.
- 5. REFER TO PANEL SCHEDULE FOR ALL WIRING AND CIRCUITRY.
- 6. EMERGENCY LIGHTING WITH BATTERY BACKUP.

KEY PLAN

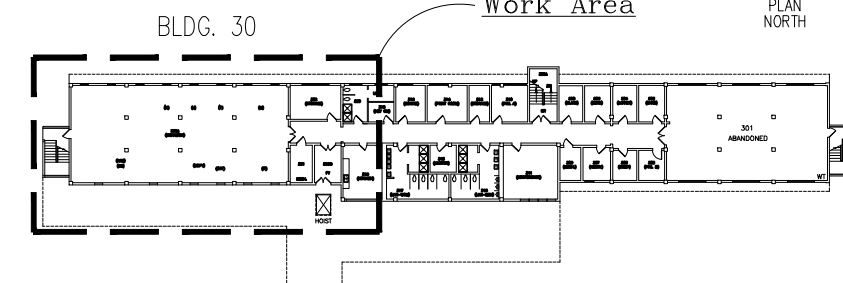

GENERAL NOTES		
NO:	REVISIONS:	DATE:

**NEW IBERIA RESEARCH CENTER
BUILDING 30 - 3RD FLOOR RENOVATION FOR (IT)**

UL FACILITY MANAGEMENT
THE UNIVERSITY OF LOUISIANA AT LAFAYETTE
P.O. BOX 43646
LAFAYETTE, LOUISIANA 70504



PROJECT NO:	SHEET:
DATE: SEPT. 2023	E1
SCALE: 1" = 0"	

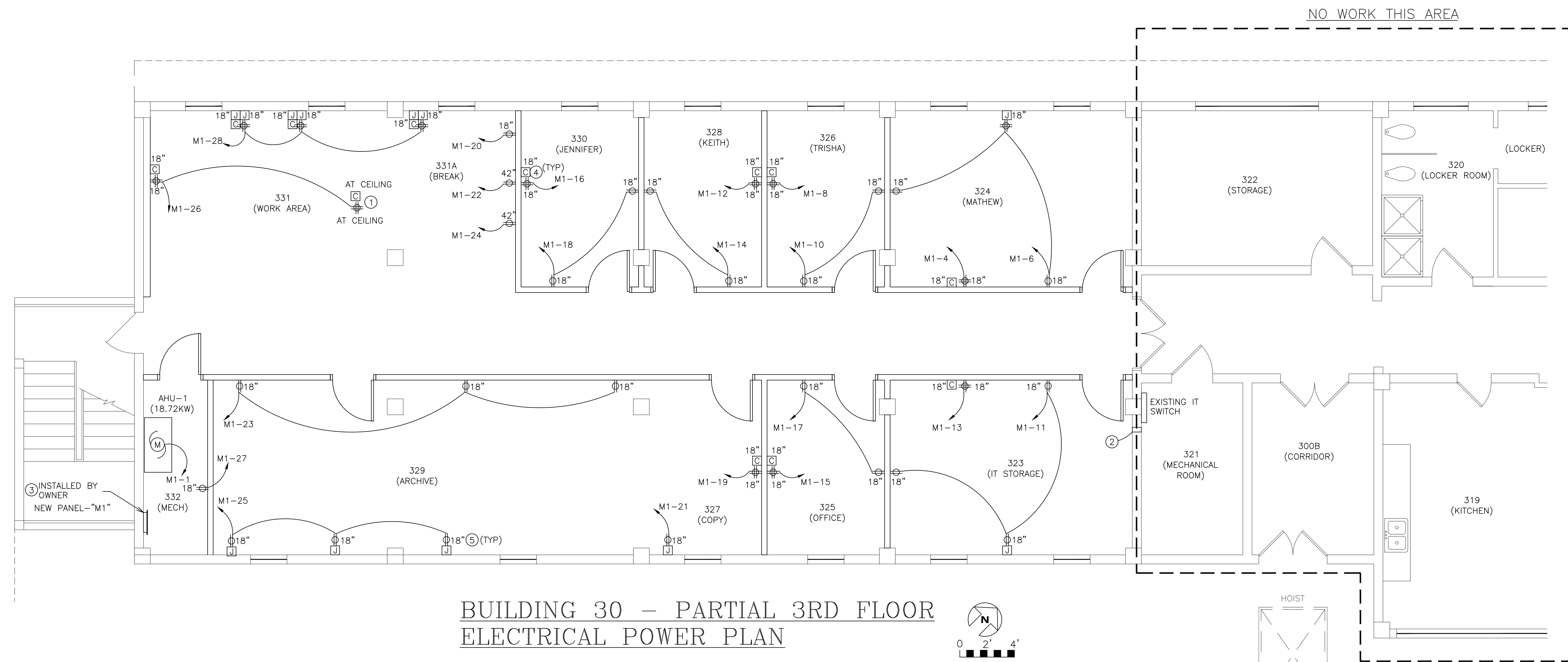

**BUILDING 30 - PARTIAL 3RD FLOOR
ELECTRICAL POWER PLAN**

ELECTRICAL PLAN GENERAL NOTES:

- A. REFER TO MOUNT HEIGHT DESIGNATION LOCATED NEXT TO OUTLET SYMBOL
- B. ALL CONDUIT ABOVE CEILING SHALL BE RATED FOR INSTALLATION WITHIN A RETURN AIR PLENUM.
- C. ROUTE ALL CONDUIT AS HIGH AS POSSIBLE.
- D. ALL CONDUIT IN WALLS SHALL BE EMT.
- E. VERIFY EXACT LOCATION OF ALL RECEPTACLES AND IT OUTLETS WITH OWNER PRIOR TO INSTALLATION. COORDINATE WITH NEW FURNITURE LAYOUT.
- F. ALL IT WIRING SHALL BE PLENUM RATED.
- G. ALL RECEPTACLES AND SWITCHES SHALL BE 20-AMP DEVICES. DEVICES AND COVER PLATES SHALL BE IVORY.
- H. ALL CONDUIT AND RACEWAYS SHALL BE STRAPPED AND ANCHORED TO EXISTING ROOF STRUCTURE.
- I. ALL POWER FEED TO NEW DEVICES AND EQUIPMENT SHALL COME FROM EXISTING PANEL "M-1" IN ROOM 332.

ELECTRICAL NOTES:

- ① - COORDINATE LOCATION OF PROJECTOR AND IT OUTLET WITH OWNER.
- ② - PROVIDE 2 INCH HOLE THROUGH EXISTING WALL FOR NEW IT WIRING.
- ③ - OWNER SHALL PROVIDE AND INSTALL NEW 120V/208V/3PH/60HZ, 42 SLOT, NEMA-1, FLUSH MOUNTED PANEL. OWNER SHALL COORDINATE LOCATION OF NEW FLUSH MOUNTED ELECTRICAL PANEL WITH NEW FILING CABINETS.
- ④ - TYPICAL ALL AREAS. FURNISH AND INSTALL NEW DATA AND POWER DROPS AS PER PLANS AND SPECIFICATIONS IN NEW WALLS AND SURFACE OF EXISTING WALLS. ALL DATA DROP ROUGH-INS BY ELECTRICAL CONTRACTOR. ALL DATA WIRING AND DEVICES BY OTHERS. ALL DATA DROPS SHALL BE 4" x 4" x 2" DEEP BOXES WITH 4" x 2" FINISH RINGS AND A 1" CONDUIT TO 6" ABOVE CEILING.
- ⑤ - TYPICAL ALL AREAS. COORDINATE LOCATIONS FOR ALL RECEPTACLES AND SWITCHES WITH OTHER TRADES, DISPLAYS, AND SHELVING.

SYMBOL LEGEND:

- J # - SURFACE MOUNTED JUNCTION BOX FOR EXTERIOR WALL INSTALLATION (IT AND RECP.) # = MOUNTING HEIGHT.
- C # - IT AND PONE CONNECTION. # = MOUNTING HEIGHT.
- Φ # - ELECTRICAL OUTLET - DUPLEX TYPE. # = MOUNTING HEIGHT.
- ⊕ # - ELECTRICAL OUTLET - QUAD. TYPE. # = MOUNTING HEIGHT.
- ⌈ - NEW ELECTRICAL PANEL BY OWNER.

KEY PLAN

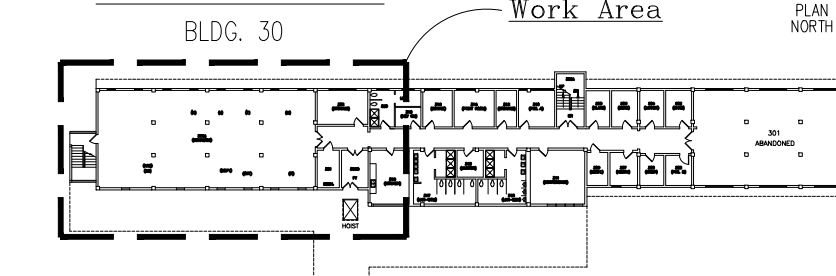

GENERAL NOTES		
NO:	REVISIONS:	DATE:

**NEW IBERIA RESEARCH CENTER
BUILDING 30 - 3RD FLOOR RENOVATION FOR (IT)**

UL FACILITY MANAGEMENT
THE UNIVERSITY OF LOUISIANA AT LAFAYETTE
P.O. BOX 43646
LAFAYETTE, LOUISIANA 70504



PROJECT NO:	SHEET:
DATE: SEPT. 2023	E2
SCALE: 1" = 0"	

NIRC - BUILDING 30 - 3RD FLOOR RENOVATION FOR IT-ARCH

NEW ELECTRICAL SERVICE PANEL SCHEDULE

M1	PANEL: "M1" 120/208V, 3Ø 4W - 2" COND. FLUSH MOUNTED NEMA -1 PANEL BOARD		200 AMP MAIN BREAKER 200 AMP NEUTRAL								
ROOM/EQUIPMENT	CKT	BRKR SIZE	WIRE	GND	MIN. COND.						DESCRIPTION
AHU-1, 18.72KW HEATER (3 PHASE)	1	80A	#4	#8	1-1/4"						ROOMS 323, 325, 327, 329 (LIGHTS)
	3										ROOM 324 (QUAD OUTLETS)-COMPUTER
	5										ROOM 324 (DUPLX OUTLETS)
ROOMS 324, 326, 328, 330, 331 (LIGHTS)	7	20A	#12	#12	1/2"						ROOM 326 (QUAD OUTLETS)-COMPUTER
CORRIDOR 300A (LIGHTS)	9	20A	#12	#12	1/2"						ROOM 326 (DUPLX OUTLETS)
ROOM 323 (QUAD OUTLETS)-COMPUTER	11	20A	#12	#12	1/2"						ROOM 328 (QUAD OUTLETS)-COMPUTER
ROOM 323 (DUPLX OUTLETS)	13	20A	#12	#12	1/2"						ROOM 328 (DUPLX OUTLETS)
ROOM 325 (QUAD OUTLETS)-COMPUTER	15	20A	#12	#12	1/2"						ROOM 330 (QUAD OUTLETS)-COMPUTER
ROOM 325 (DUPLX OUTLETS)	17	20A	#12	#12	1/2"						ROOM 330 (DUPLX OUTLETS)
ROOM 327 (QUAD OUTLETS)-COPIER	19	20A	#12	#12	1/2"						ROOM 331A (DUPLX OUTLETS)-MICROWAVE
ROOM 327 (DUPLX OUTLETS)	21	20A	#12	#12	1/2"						ROOM 331A (DUPLX OUTLETS)-COFFEE MKR.
ROOM 329 (DUPLX OUTLETS)-NORTH WALL	23	20A	#12	#12	1/2"						ROOM 331A (DUPLX OUTLETS)-TOASTER
ROOM 329 (DUPLX OUTLETS)-SOUTH WALL	25	20A	#12	#12	1/2"						ROOM 331 (QUAD OUTLETS)-PROJECTOR
ROOM 332 (DUPLX OUTLETS)	27	20A	#12	#12	1/2"						ROOM 331 (QUAD OUTLETS)-COMP. STATION
SPACE	29										SPACE
	31										
	33										
	35										
	37										
	39										
	41										
REMARKS:											

- NOTES:**
- FURNISH AND INSTALL A NEW 120/208 VOLT, 42 SPACE, 3-PHASE, 4-WIRE, FLUSH MOUNT PANEL BOARD WITH 200 AMP MAIN BREAKER, FLOATING NEUTRAL BAR, AND CIRCUIT BREAKERS AS SHOWN ON PLANS. NEW PANEL SHALL BE LABELED AS "M1". PROVIDE NEW SPARE BREAKERS AS SHOWN.
 - RUN A NEW 2" CONDUIT FROM EXISTING PANEL AT EXTERIOR OF BUILDING TO NEW PANEL "M1" IN ELECTRICAL ON WALL IN ROOM 329. LABEL EXISTING PANEL "1LPD" DIRECTORY AS SUCH.
 - FURNISH A TYPED PANEL DIRECTORY IN EACH PANEL.

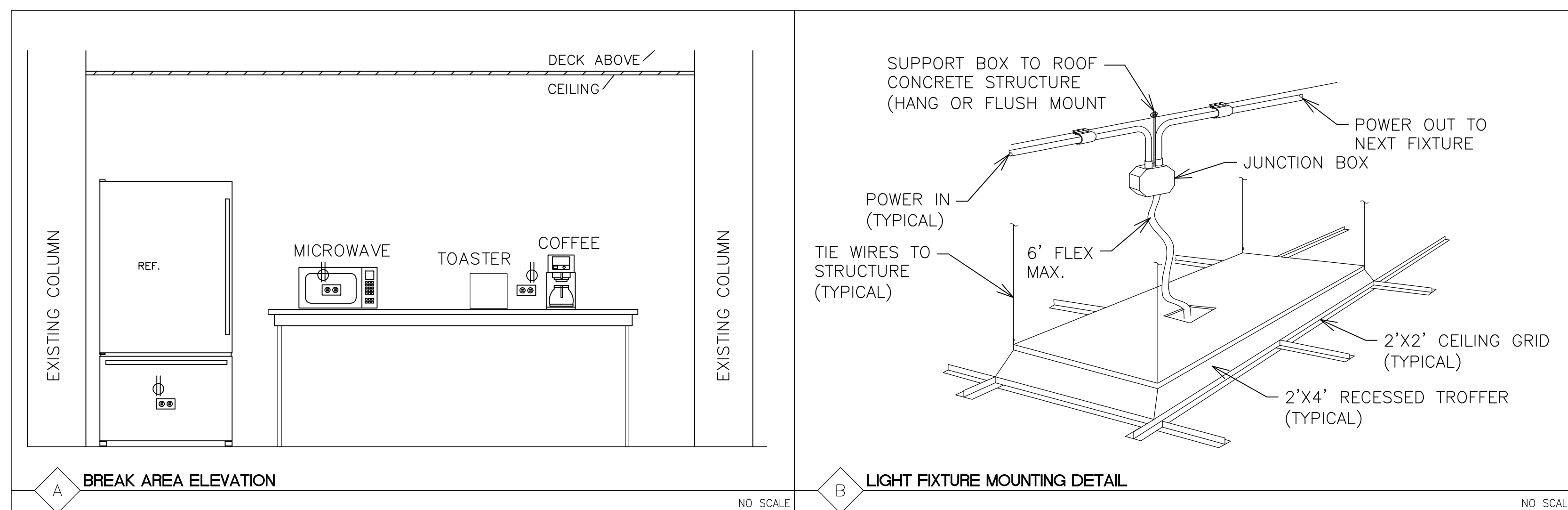

GENERAL NOTES		
NO:	REVISIONS:	DATE:

NEW IBERIA RESEARCH CENTER BUILDING 30 - 3RD FLOOR RENOVATION FOR (IT)

UL FACILITY MANAGEMENT
 THE UNIVERSITY OF LOUISIANA AT LAFAYETTE
 P.O. BOX 43646
 LAFAYETTE, LOUISIANA 70504

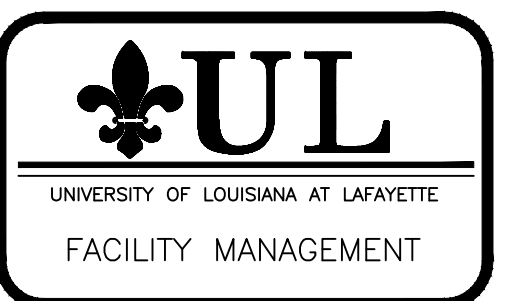

PROJECT NO:	SHEET:
DATE: SEPT. 2023	E3
SCALE: 1" = 0"	